

research report

Inelastic Performance of Screw Connected CFS Strap Braced Walls

RESEARCH REPORT RP08-5

2008



American Iron and Steel Institute



Steel Framing Alliance™

Steel. The Better Builder.

DISCLAIMER

The material contained herein has been developed by researchers based on their research findings and is for general information only. The information in it should not be used without first securing competent advice with respect to its suitability for any given application. The publication of the information is not intended as a representation or warranty on the part of the American Iron and Steel Institute, Steel Framing Alliance, or of any other person named herein, that the information is suitable for any general or particular use or of freedom from infringement of any patent or patents. Anyone making use of the information assumes all liability arising from such use.

PREFACE

The *North American Standard for Cold-Formed Steel Framing - Lateral Design*, AISI S213-07, provides design provisions for cold-formed steel framed walls with diagonal strap bracing. Presented in this report are the findings from an extensive monotonic and cyclic testing program conducted at the McGill University to verify the capacity based design approach, the R_d and R_o values and the building height limit as found in AISI S213-07 for limited ductility concentrically braced frames with screw connections.

It is anticipated that the results of this study will be incorporated in future standards developed by the AISI Committee on Framing Standards and design aids developed by the Cold-Formed Steel Engineers Institute.

Inelastic Performance of Screw Connected Cold-Formed Steel Strap Braced Walls

By

Kostadin Velchev

Project Supervisor

Colin A. Rogers



Department of Civil Engineering and Applied Mechanics

McGill University, Montreal, Canada

November 2008

**A thesis submitted to the Faculty of Graduate and
Postdoctoral Studies in partial fulfillment of the requirements
of the degree of Master of Engineering**

© Kostadin Velchev, 2008

ABSTRACT

Guidelines that address the seismic design of cold-formed steel structures are not provided in the 2005 NBCC or in the CSA S136 Specification. The revised version of AISI S213 does, however, contain Canadian provisions for the seismic design of strap braced walls. This standard specifies seismic force modification factors and height limits for the two categories of diagonal strap braced (concentric) walls: Limited ductility (LD) $R_d = 2.0$, $R_o = 1.3$, building height limit of 20 m, and Conventional construction (CC) $R_d = 1.25$, $R_o = 1.3$, building height limit of 15 m for low seismic zones.

In order to evaluate the lateral in-plane behaviour of screw connected type LD CFS strap braced walls, and the R_d , R_o and building height limits given in AISI S213, a total of 30 wall specimens (2.44 m x 2.44 m) detailed following capacity design principals were fabricated and subjected to monotonic and CUREE reversed cyclic loading protocols. To avoid net cross section fracture at brace connections two different detailing methods were applied; special screw patterns and braces with reduced strap widths. Similarly, to fully investigate the behaviour of the braced walls tests of specimens having fuse braces, reinforced tracks, different holddown positions and brace screws attached to the interior framing studs were carried out. Furthermore, two different approaches were used to confirm the seismic force modification factors in AISI S213. Initially, R_d and R_o were calculated for type LD walls based on the ductility and overstrength measured from the wall tests following the procedure used by Mitchell et al. This was followed by an evaluation of the R-values and height limit of the type CC walls using the methodology of ATC-63. To apply this new method non-linear dynamic analyses of representative multi-storey buildings designed according to the 2005 NBCC and AISI S213 were carried out. Real and synthetic ground motions were scaled to match the 2005 NBCC UHS for Vancouver, Quebec, Halifax and Calgary.

The test results illustrated that all wall specimens were able to maintain their yield strength and develop plastic deformations in the braces during lateral loading. This behaviour confirms that the capacity design procedure in AISI S213 provides for adequate ductility in type LD strap braced walls. In addition, the ATC-63 procedure was used to validate the current values of $R_d = 1.25$, $R_o = 1.3$ and the 15 m building height limit listed in AISI S213 for conventional construction strap braced walls.

RÉSUMÉ

Les directives pertinentes à la conception sismique des bâtiments en structure d'acier formé à froid n'existent pas encore dans le Code National du Bâtiment du Canada CNBC 2005 ainsi que la norme CSA S136. Cependant, la version révisée du AISI S213 contient des conditions canadiennes pour la conception sismique des cadres avec contreventements concentriques. Ce dernier spécifie les facteurs de modification ainsi que les limites de hauteur pour les deux catégories de cadres avec contreventements concentriques: Ductilité limitée (DL) $R_d = 2.0$, $R_o = 1.3$, limite de hauteur du bâtiment de 20 m, et construction conventionnelle (CC) $R_d = 1.25$, $R_o = 1.3$, limite spécifiée de 15 m pour les bâtiments pour les zones sismiques de faible intensité.

Pour pouvoir évaluer le comportement dans le plan de cadres de type DL construits avec des vises et des lanières en acier formé à froid, 30 spécimens de 2.44 m sur 2.44 m furent fabriqués en respectant les principes de conception sismique basée sur la capacité du système. Ceux-ci ont alors été soumis à des protocoles de chargements monotones et des chargements cycliques comme défini par CUREE. Les tests ont aussi permis de valider les valeurs de R_d , R_o ainsi que les limites de hauteur définies dans AISI S213. Pour éviter une rupture de la section nette au niveau des connections, deux méthodes d'assemblage furent employées: l'utilisation d'arrangements de vises particuliers ou bien l'utilisation de lanières avec une largeur réduite. Les effets de la présence de contreventements conçus comme fusibles, de rails renforcés, de l'emplacement des fixations verticales et de l'emplacement des connecteurs qui attachaient les contreventements à l'ossature du mur ont aussi été examinés. Les valeurs de R_d et R_o ont été calculés pour des cadres de type DL en tenant compte de la ductilité et de l'écroutissage en suivant la procédure définie par Mitchell et al. Cela fut complété par une évaluation des facteurs de modifications et de la limite de hauteur pour les cadres de type CC en utilisant la méthodologie de l'ATC-63. L'utilisation de cette nouvelle méthode nécessitât plusieurs analyses dynamiques non linéaires de bâtiments conçus selon le CNBC 2005 et AISI S213. Les enregistrements de tremblements authentiques ainsi que fictifs utilisés furent ajustés à des échelles spécifiques pour être comparable au spectre du CNBC 2005 pour Vancouver, Québec, Halifax et Calgary.

Les résultats démontrèrent que tous les spécimens de cadres réussissaient à maintenir leur limite d'élasticité et à plastifier au niveau des contreventements quand ils étaient soumis à des chargements latéraux. Ce comportement confirme que la procédure de conception basée sur la capacité, comme spécifié dans AISI S213, arrive à une ductilité adéquate pour les cadres de type LD. La méthode définie par ATC-63 fut aussi utilisée pour valider les valeurs actuelles listées dans AISI S213 de $R_d=1.25$, $R_o=1.25$ et la limite de hauteur de 15 mètres pour un bâtiment avec des cadres avec lanières de construction conventionnelle.

ACKNOWLEDGEMENTS

Thanks to the funding partners who made this research possible: The Canadian Sheet Steel Building Institute, The Canada Foundation for Innovation, The Natural Sciences and Engineering Research Council, and The American Iron and Steel Institute. I also would like to thank out material suppliers: ITW Buildex, Bailey Metal Products, Grabber Construction Products, Simpson Strong-Tie, and CANAM Group.

TABLE OF CONTENTS

ABSTRACT.....	i
RÉSUMÉ	ii
ACKNOWLEDGEMENTS	iv
TABLE OF CONTENTS.....	v
LIST OF FIGURES.....	viii
LIST OF TABLES	xiii
CHAPTER 1 INTRODUCTION.....	1
1.1 GENERAL OVERVIEW.....	1
1.2 STATEMENT OF PROBLEM.....	2
1.3 OBJECTIVES.....	2
1.4 SCOPE.....	3
1.5 LITERATURE REVIEW.....	4
1.5.1 Performance of cold-formed steel strap braced walls	4
1.5.2 Seismic design and analysis.....	8
1.5.3 Conclusions.....	11
CHAPTER 2 TEST PROGRAM.....	13
2.1 CAPACITY DESIGN APPROACH.....	17
2.1.1 Design of regular and fuse braces	19
2.1.2 Design of chord studs.....	22
2.1.3 Design of screw connections.....	23
2.1.4 Design of gusset plates.....	24
2.1.5 Design of holddowns.....	26
2.1.6 Design of tracks	29
2.2 CONSTRUCTION DETAILS OF LIGHT TEST WALLS	32
2.3 CONSTRUCTION DETAILS OF MEDIUM TEST WALLS	40
2.4 CONSTRUCTION DETAILS OF HEAVY TEST WALLS	48
2.5 TEST ASSEMBLY AND INSTRUMENTATION	57

2.6 MONOTONIC LOAD PROTOCOL	60
2.7 REVERSED CYCLIC LOAD PROTOCOL	60
2.8 MEASURED AND PREDICTED PROPERTIES	63
2.8.1 <i>Stiffness properties</i>	64
2.8.2 <i>Lateral resistance properties</i>	68
2.8.3 <i>Seismic design properties</i>	70
2.8.4 <i>Energy</i>	71
2.9 MATERIAL PROPERTIES	72
2.10 OBSERVED PERFORMANCE	74
2.10.1 <i>Observed Performance for Test Walls with Fuse Braces</i>	76
2.10.2 <i>Observed Performance for Test Walls with Regular Braces</i>	80
2.11 SUMMARY AND DISCUSSION OF TEST RESULTS	85
2.11.1 <i>Test Walls with Fuse Braces</i>	89
2.11.2 <i>Test Walls with Regular Braces</i>	92
CHAPTER 3 DYNAMIC ANALYSES	96
3.1. INTRODUCTION	96
3.2. DESIGN OF BUILDING MODELS	96
3.2.1. <i>Building description</i>	96
3.2.2. <i>Gravity loads</i>	99
3.2.3. <i>Seismic loads</i>	101
3.3. DESIGN OF BRACES AND STOREY DEFLECTION	106
3.4. NONLINEAR DYNAMIC ANALYSIS	109
3.4.1. <i>Earthquake Records</i>	109
3.4.2. <i>Hysteretic Behaviour of Walls</i>	115
3.4.3. <i>RUAUMOKO model of the selected buildings</i>	119
3.4.4. <i>Storey drift analysis</i>	121
3.5 ATC-63 METHODOLOGY FOR EVALUATION OF R_d , R_o AND HEIGHT LIMIT	124
3.5.1. <i>Incremental dynamic analysis</i>	124
3.5.2. <i>Fragility curve</i>	127
3.5.3. <i>Evaluation of the structure performance following ATC-63</i>	130
CHAPTER 4 CONCLUSIONS AND RECOMMENDATIONS.....	131

4.1. CONCLUSIONS	131
4.1.1 <i>Test Program</i>	131
4.1.2 <i>Dynamic Analyses</i>	132
4.2. RECOMMENDATIONS FOR FUTURE STUDIES.....	133
REFERENCES	134
APPENDIX A: INDIVIDUAL TEST RESULTS SUMMARIES.....	139
APPENDIX B: STRAIN GAUGE LOCATIONS	177
APPENDIX C: TEST DATA SHEETS AND OBSERVATIONS	180
APPENDIX D: RUAUMOKO INPUT FILES.....	236
APPENDIX E: EXAMPLE HYSTERESIS AND TIME HISTORY FOR FIVE STOREY VANCOUVER MODEL SUBJECTED TO SPECTRUM MATCHED (SM) GROUND MOTION	239
APPENDIX F: SCREW CONNECTION TESTS.....	243
APPENDIX G: HOLDDOWN POSITION	245

LIST OF FIGURES

Figure 1.1 Example of building with screw connected strap braces.....	1
Figure 2.1 Strap braced wall specimen 46A-C in test frame	13
Figure 2.2 Schematic drawings of strap braces.....	15
Figure 2.3 Schematic of strap braced wall specimen in test frame.....	17
Figure 2.4 Corner detail of a wall with regular and fused braces	20
Figure 2.5 Monotonic resistance light and heavy strap braced walls	22
Figure 2.6 Corner details light and medium walls	25
Figure 2.7 Whitmore section and a corner detail of a heavy wall	25
Figure 2.8 Details of the corner and U-shaped holddown of specimens 41A-M and 44A-C.....	27
Figure 2.9 Details of the corner and U-shaped holddown of specimens 43A-M and 44A-C.....	27
Figure 2.10 Punching shear failure mode (<i>Al-Kharat and Rogers, 2005</i>)	28
Figure 2.11 Design model for the steel plate	29
Figure 2.12 Track details showing track force.....	31
Figure 2.13 Reinforced track (left) vs. extended track with increased bearing resistance (right).....	31
Figure 2.14 Nominal dimensions and the corner detail of specimens 25A-M and 26A-C.....	34
Figure 2.15 Nominal dimensions and the corner detail of specimens 31A-M and 32A-C.....	35
Figure 2.16 Nominal dimensions and the corner detail of specimens 35A-M and 36A-C.....	36
Figure 2.17 Nominal dimensions and the corner detail of specimens 41 A-M and 42 A-C.....	37
Figure 2.18 Specimen 25 A-M prior to testing	38
Figure 2.19 Corner detail of specimens 31 A-M and 35A-M.....	38
Figure 2.20 Specimen 42 A-C prior to testing.....	39
Figure 2.21 Corner details of specimen 42 A-C	39

Figure 2.22 Nominal dimensions and the corner detail of specimen 9C-M	42
Figure 2.23 Nominal dimensions the corner detail of specimens 27A-M and 28A-C	43
Figure 2.24 Nominal dimensions and the corner detail of specimens 39A-M and 40A-C	44
Figure 2.25 Nominal dimensions and the corner detail of specimens 47A-M and 48A-C	45
Figure 2.26 Strap braced wall specimen 27 A-M in test frame	46
Figure 2.27 Holddown detail of specimen 27 A-M	46
Figure 2.28 Strap braced wall specimen 40 A-C in test frame	47
Figure 2.29 Holddown and track reinforcement detail of specimen 40 A-C	47
Figure 2.30 Corner details of specimen 48 A-C (left) and 9 C-M (right).....	48
Figure 2.31 Nominal dimensions and corner detail of specimen 29A-M 1	50
Figure 2.32 Nominal dimensions and corner detail of specimens 29A-M 2 and 30A-C	51
Figure 2.33 Nominal dimensions and corner detail of specimens 33A-M and 34A-C	52
Figure 2.34 Nominal dimensions corner detail of specimens 37A-M and 38A-C	53
Figure 2.35 Nominal dimensions and corner detail of specimens 45A-M and 46A-C	54
Figure 2.36 Strap braced wall specimen 30 A-C in test frame	55
Figure 2.37 Corner detail of specimen 30 A-C	55
Figure 2.38 Corner detail of specimen 34 A-C	56
Figure 2.39 Strap braced wall specimen 37 A-M in test frame	56
Figure 2.40 Corner detail of specimens 37 A-M (left) and 38A-C (right).....	57
Figure 2.41 Corner detail of specimen 46 A-C	57
Figure 2.42 Typical anchorage for walls specimens, mm.....	58
Figure 2.43 Positioning of the LVDTs and the string potentiometer.....	59
Figure 2.44 Typical shear resistance vs. deflection curve for.....	60
Figure 2.45 Typical reversed cyclic test protocol (Specimen 28A-C).....	61
Figure 2.46 Shear resistance vs. deflection response curve	62

Figure 2.47 Definition of measured wall parameters for monotonic and cyclic tests	63
Figure 2.48 Model for the predicted stiffness	65
Figure 2.49 Connection test	66
Figure 2.50 Test Specimen photographs showing elongated fuse section.....	76
Figure 2.51 Typical wall at the end of a monotonic test (test specimen 25 A-M 1)	77
Figure 2.52 Distortional buckling of a chord stud of specimen 25A-M 1 (left) and net cross-section failure of a brace of specimen 25A-M 2 at 3.6% drift (right) ...	78
Figure 2.53 Net section fracture of braces of specimen 27A-M 1 at 8.6% drift...	78
Figure 2.54 Net section fracture of braces of specimen 27A-M 2 at 3.6% drift...	79
Figure 2.55 Lüder’s band lines (left) and net cross-section failure of a brace (right) of specimen 31A-M 2 at 4.5% drift	79
Figure 2.56 Block shear failure of flanges of the bottom track and bending of chord studs of specimen 32A-C	80
Figure 2.57 Net cross-section failure of a brace of specimen 35A-M 1 at 8% drift	82
Figure 2.58 Bending of chord studs of specimen 36A-C.....	83
Figure 2.59 Block shear failure of flanges of the bottom track and bending of chord studs of specimen 36A-C	83
Figure 2.60 Compression and bearing failure of the bottom track of specimen 37A-M.....	84
Figure 2.61 Compression and bearing failure of the bottom track of specimen 39A-M.....	84
Figure 2.62 Net section fracture of braces of specimen 45A-M at 7.6% drift.....	84
Figure 2.63 Monotonic resistance light and heavy fuse strap braced walls.....	90
Figure 2.64 Cyclic resistance light and heavy short fuse strap braced walls.....	90
Figure 2.65 Cyclic resistance light and heavy long fuse strap braced walls.....	91
Figure 2.66 Monotonic and cyclic resistance vs. deflection for light walls.....	94
Figure 2.67 Monotonic and cyclic resistance vs. deflection for light walls with U-shaped holddown	94

Figure 2.68 Monotonic and cyclic resistance vs. deflection for heavy walls with U-shaped holddown	95
Figure 2.69 Monotonic and cyclic resistance vs. deflection for heavy walls with reinforced track	95
Figure 3.1 West elevation and plan view of the representative	97
Figure 3.2 Plan view and location of braced bents (<i>Cobeen et al., 2007</i>)	98
Figure 3.3 Schematics of the braced bents.....	98
Figure 3.4 Hambro [®] D500 floor system (<i>Canam Group, 2004</i>).....	100
Figure 3.5 Torsional effects	103
Figure 3.6 Shear deflection model	107
Figure 3.7 Ground motions scaled to 2005 NBCC UHS for Calgary.....	113
Figure 3.8 Ground motions scaled to 2005 NBCC UHS for Halifax	113
Figure 3.9 Ground motions scaled to 2005 NBCC UHS for Quebec	113
Figure 3.10 Ground motions scaled to 2005 NBCC UHS for Vancouver.....	114
Figure 3.11 Spectrum matched ground motions	114
Figure 3.12 Mean scaled earthquake spectra compared to design UHS.....	115
Figure 3.13 Bi-linear with Slackness Hysteresis (<i>Carr, 2000</i>).....	116
Figure 3.14 Superposition of bilinear with slackness model	116
Figure 3.15 Braced bents and corresponding equivalent column models.....	119
Figure 3.16 Shear versus brace model (<i>Comeau 2008</i>)	120
Figure 3.17 Storey drift of two-storey buildings under UHS scaled earthquake records.....	121
Figure 3.18 Storey drift of four-storey buildings under UHS scaled earthquake records.....	122
Figure 3.19 Storey drift of five-storey buildings under UHS scaled earthquake records.....	123
Figure 3.20 IDA analyses for all 2 storey buildings	125
Figure 3.21 IDA analyses all 4 storey buildings.....	125
Figure 3.22 IDA analyses for all 5 storey buildings	126
Figure 3.23 Fragility curves for all 2 storey buildings.....	127
Figure 3. 24 Fragility curves for all 4 storey buildings.....	128

Figure 3.25 Fragility curves for all 5 storey buildings..... 128

LIST OF TABLES

Table 2.1 Matrix of strap braced wall test specimens.....	14
Table 2.2 Expected forces in SFERS due to brace yielding and brace fracture	21
Table 2.3 Nominal Axial compression resistance of back-to back chord studs ...	23
Table 2.4 Axial tension resistance of gusset plates.....	26
Table 2.5 Nominal axial resistance of track sections.....	30
Table 2.6 Nominal bearing resistance of track sections	32
Table 2.7 Material properties of strap braces.....	73
Table 2.8 Material properties of studs, tracks and gusset plates.....	73
Table 2.9 Summary of observed performance during braced wall testing	75
Table 2.10 Summary of monotonic test results.....	85
Table 2.11 Summary of monotonic test results (US customary units)	86
Table 2.12 Summary of reversed cyclic test information	87
Table 2.13 Summary of reversed cyclic test information (US customary units)..	88
Table 3.1 Short period spectral acceleration categories in 2005 NBCC and AISI S213	99
Table 3.2 Dead loads.....	100
Table 3.3 Snow Load as prescribed by the 2005 NBCC	101
Table 3.4 Lateral load calculations	104
Table 3.5 Lateral load calculations (US customary units).....	105
Table 3.6 Selected brace sizes.....	106
Table 3.7 Interstorey drift	108
Table 3.8 Interstorey drift (US customary units).....	109
Table 3.9 Summary of ground motions for Calgary, Halifax and Quebec site class “C”	111
Table 3.10 Summary of ground motions for Vancouver site class “C”	112
Table 3.11 Model design summary.....	118
Table 3.12 Periods of Vibration for Building Models	120
Table 3.13 Summary of storey drifts	123
Table 3.14 ATC 63 parameters for determining model acceptance	129

Chapter 1 Introduction

1.1 GENERAL OVERVIEW

Cold-formed steel (CFS) structures are commonly being constructed in North America, including areas with high seismic hazard where often the lateral design of a building will be controlled by earthquake loading. The seismic design of a building becomes an important part of the design process where earthquake forces should be transferred from upper storeys to the foundations by means of a seismic force resisting systems (SFRS). In a CFS building diagonal strap braced walls can be used as the SFRS (Figure 1.1). A CFS strap braced wall is comprised of top and bottom tracks, vertical chord studs, diagonal strap braces and their connections, framing studs and holddown fixtures at the corners; these elements are designed to be able to transfer the lateral earthquake load to the foundations. The SFRS is detailed such that the braces are able to develop plastic deformation to dissipate earthquake energy and to allow for ductile behaviour. This seismic design approach is known as capacity design.



Figure 1.1 Example of building with screw connected strap braces

1.2 STATEMENT OF PROBLEM

Provisions that address the seismic design of CFS strap braced walls cannot be found in the 2005 National Building Code of Canada (NBCC) (*NRCC, 2005*) or in the CSA S136 Specification (*2007*) for cold-formed steel design. The Canadian portion of the American Iron and Steel Institute (AISI) North American CFS lateral design standard (*AISI S213, 2007*) does, however, provide guidance, in terms of seismic force modification factors, height limits, detailing and material requirements, etc, for the seismic design of structures that must meet the requirements of the 2005 NBCC. This standard lists two types of concentrically braced wall configurations; limited ductility (type LD) and conventional construction (type CC), which differ in terms of design and expected ductile performance. AISI S213 also directs the engineer to use welded connections at brace ends to avoid the possibility of strap fracture. Given the widespread use of screw connections in the CFS construction industry there was a need to investigate the inelastic performance of type LD strap braced walls constructed using these mechanical fasteners and having reduced width (fuse) braces, reinforced tracks, and raised holddowns. It was also necessary to validate the effectiveness of the detailing provisions in AISI S213 with respect to providing ductility in type LD walls having regular screw connected strap braces given the recent findings of Al-Kharat and Rogers (*2005, 2006, 2007, 2008*). Lastly, verification of the building height limit for conventional construction strap braced buildings needed to be carried out.

1.3 OBJECTIVES

This research project was undertaken to: 1. Investigate the lateral in-plane inelastic behaviour of type LD screw connected CFS strap braced walls designed following capacity design principals; 2. Provide specific connection and seismic force resisting system details; 3. Determine the seismic force modification

factors based on measured ductility and overstrength of the tested specimens; 4. Perform non-linear dynamic time history analyses and evaluate the imposed R_d , R_o and height limits from AISI S213 for type CC strap braced walls following the ATC-63 (2008) methodology.

1.4 SCOPE

In the first part of the project a total of thirty screw-connected single-storey wall specimens 2.44 m x 2.44 m in size were designed according to the capacity design philosophy required by AISI S213 and then subjected to monotonic and CUREE reversed cyclic loading protocols. Three factored lateral load levels were used in design; 20 kN (light), 40 kN (medium) and 75 kN (heavy). All but two specimens were constructed with diagonal cross bracing on both sides of the wall. Ten wall specimens were fabricated with fuse (reduced width) braces. During testing lateral load and displacement, strain in the braces, as well as the slip and uplift at the base of the wall were recorded. These measurements were used to calculate the wall resistance, stiffness, ductility and energy dissipation. Also, R_d and R_o values based on the test data were computed and compared with those listed in AISI S213 for type LD walls.

In the second part of the project a computer model was developed and calibrated with the test results. Non-linear dynamic analyses using a total of 45 scaled earthquake records were conducted using the software Ruaumoko (Carr, 2000) to examine the behaviour of two, four, and five storey representative residential buildings assumed to be situated in four different Canadian cities: Calgary, Halifax, Quebec, and Vancouver. The ATC-63 (2008) methodology, adapted for Canadian design, was followed to evaluate the seismic force modification factors and height limits for type CC strap braced walls in the current AISI S213 standard.

1.5 LITERATURE REVIEW

This section summarizes previous research conducted on the behaviour and analyses of CFS framed walls. The information collected from this previous testing was very helpful in the selection and detailing of wall configurations that would have desirable inelastic behaviour, as well as the choice of test and analysis methods.

1.5.1 Performance of cold-formed steel strap braced walls

Adham et al. (1990) investigated the lateral resistance of six 2.44 m × 2.44 m cold-formed steel planar frames sheathed with gypsum. Five of the specimens were X-braced with 50.8 mm and 76.2 mm wide straps with three different thicknesses (0.84, 1.09 and 1.37 mm) screw connected to gusset plates. The uplift forces were taken from two holddowns, one for each end, bolted to the base of the test setup. Adham et al. concluded that strap braced walls are effective as a seismic resisting system; however, the failure modes that they observed (stud buckling, net cross failure of a brace and compression failure of a track) can severely reduce the wall resistance.

Serrette and Ogunfunmi (1996) investigated the shear behaviour of thirteen 2.44 m x 2.44m screw connected light-gauge steel stud walls which were divided into three groups in accordance with the shear resisting system: three walls braced with 50.8 mm x 0.88 mm X-straps on one side only, five walls sheathed with 12.5 mm gypsum wallboard on both sides, and four walls braced with 50.8 mm x 0.88 mm X-straps on one side and 12.5 mm gypsum wallboard on both sides. Also, an additional specimen braced with 50.8 mm x 0.88 mm X-straps on both sides was tested. In the X-braced wall specimens the straps were connected to 254 mm x 254 mm 0.88 mm thick gusset plates using No. 8 wafer head screws. This connection was designed for the yield strength of the straps. The authors reported that the resistance of the braced specimens is controlled by the yield strength of

the straps and the contribution of the chords studs is negligible, despite the elastic bending of the cord studs that was observed during testing. In contrast, the maximum resistance of sheathed specimens was governed by the breaking of the wallboard panel and partial pull-through of the screws at the edges of the wall. Also, it was noted that the use of straps and sheathing together is not practical regardless of the higher strength of the walls.

Gad et al. (1999) assessed the lateral resistance and behaviour of 2.4 x 2.4 m cold-formed steel frames under seismic loading. Unlined frames braced with 25 mm wide and 1 mm thick straps, plasterboard lined walls, and plasterboard lined walls with strap braces were subjected to cyclic racking and dynamic (shake table) testing. In order to create a realistic test model, that takes into account the boundary condition at the edge of the wall determined by the non-structural components such as transverse walls, skirting boards and ceiling cornices, a test house measuring 2.3 x 2.4 x 2.4 m high was constructed. It was reported that all test specimens performed well under earthquake loading and the lining significantly increases the lateral resistance, stiffness and damping of walls. Two different modes of failure of braces were observed: net cross section fracture, and connection failure (combination of bearing and pull-out or punching shear failure). The stiffness and strength of unlined walls is mainly due to strap braces, and the stiffness and strength of walls with strap braces and plasterboard is the sum of the contribution from straps and lining.

Fülöp and Dubina (2004) investigated the shear behaviour of six different cold-formed steel wall configurations 3.6 m long and 2.44 m high. Three of the specimens were constructed with X-braces 110 mm wide and 1.5 mm thick placed on both sides of the frame; two of the walls were tested cyclically and the remaining wall was tested monotonically. Braces were screw connected to the frame structure using self-drilling screws and the connection was designed to assure gross section yielding of the straps and to provide a high level of ductility. Fülöp and Dubina reported that for the braced specimens higher pinching was

observed for the strap braced walls compared with those with sheathing. Braces were able to yield but could not maintain their yield capacity because of unexpected failure of the corners of the test specimens. They also recommended that the uplift force should be directly transmitted to the anchor bolt without bending the bottom track.

Tian et al. (2004) carried out an experimental and theoretical study on the racking strength and stiffness of ten cold-formed steel wall frames. Five of the tested specimens were 2.45 m in height \times 1.25 m in width, braced with single or double X straps riveted to the steel framing. The three single braced specimens were fabricated with 60 mm \times 1.0 mm steel straps. Two of them were braced on two sides and one of them was braced only on one side. The two double braced specimens were fabricated with 60 mm \times 1.2 mm steel straps. Two loading methods (1-step and 3-steps) were carried out to investigate the lateral resistance and behaviour of walls. Two failure modes were observed during the tests of braced walls: overall buckling of the compression chord and bracing rivet failure. In order to predict the failure load and initial elastic shear stiffness of strap braced walls, Tian et al. performed a theoretical analysis that precisely predicted the failure load recorded during testing; however, it yielded significantly higher stiffness than that which was measured. The overestimation of the frame stiffness was attributed to imperfections of the model that was used in the analysis. For strap braced walls a large ratio (more than 1:2) of frame width to frame height is recommended.

Casafont et al. (2006) investigated the behaviour of screw connected steel straps under cyclic loading. They observed two different types of failure in the joints: combination of tilting, bearing, pull out or pull through, and tilting and net section failure. The authors concluded that the screw connected joints where the second type of failure takes place are suitable for X-braced lightweight structures because this type of failure occurs after the ductile yielding of the straps and it allows for energy dissipation during an earthquake event.

Kim et al. (2006) reported the results of a full scale shake table test of a two-storey one-bay structure braced with 102 mm x 1.4 mm cold-formed steel straps welded to the flanges of the chord studs. The dynamic test showed very ductile and highly pinched hysteresis behaviour governed by the stiffness and yielding of the straps. According to the article, the cold-formed steel building structure behaved very well under seismic loading, and special attention should be paid to the brace welded or screwed connections to the columns.

Al-Kharat and Rogers (2005, 2006, 2007, and 2008) tested thirty one 2440 x 2440 mm light gauge steel strap braced walls. The first sixteen specimens, tested in the summer of 2004, were divided into three groups. The first group of 6 specimens were braced with 58.4 mm x 1.22 mm steel straps screw connected to the chord studs. The second and the third group were fabricated with 101 mm x 1.52 mm and 152 mm x 1.91 mm steel straps, respectively, fillet welded to gusset plates. These sixteen specimens were not designed following capacity based principles; which is why elements in the SFRS were seriously damaged or fractured before yielding of the braces took place, e.g. punching shear and compression failure of the tracks. The second fifteen specimens, which were fabricated using screwed connections, were braced with 63.5 mm x 1.09 mm (light walls), 127 mm x 1.09 mm (medium walls) and 152 mm x 1.73 mm (heavy walls) and were tested in the summer of 2005. These walls were detailed following a proposed seismic capacity design approach similar to that found in CSA S16 (2005). Note; this was, however, not the case for the walls with regular length tracks. In general, the observed failure mode was gross cross-section yielding of braces. Only the test specimens fabricated with a regular track detail failed in compression or bearing of the tracks because the resistance of the track was less than the horizontal component of the probable brace force. Also, net section fracture of the braces was observed during the cyclic tests of the light and heavy walls. It was found that at higher strain rates the tensile to yield strength ratio of the steel decreases, which could lead to brace fracture. The authors recommended that a minimum F_u/F_y ratio of 1.2 be specified for brace material, in addition to the requirement for

capacity design. Al-Kharat and Rogers were able to successfully predict the lateral resistance of the test specimens. The measured elastic shear stiffness of the walls was, however, lower than that predicted using only the axial stiffness of the braces. It was recommended that the elastic stiffness of the brace connections, holddown and anchor rod also to be included in order to obtain a more accurate estimate of the lateral stiffness of a wall.

1.5.2 Seismic design and analysis

The 2005 National Building Code of Canada (*NRCC, 2005*) and the current CSA S136 Specification (*2007*) do not contain seismic design information for cold-formed steel structures. Mitchell et al. (*2003*) describe the basis of the seismic force modification factors listed in the 2005 NBCC. According to the article the force modification factor R from the 1995 NBCC (*NRCC, 1995*) is replaced and more precisely defined as the product of two new factors R_d and R_o . The ductility-related force modification factor R_d represents the ability of the structural system to dissipate seismic energy and it ranges from 1.0 to 5.0. The overstrength-related force modification factor R_o represent the reserve of strength that a structure designed according to the NBCC possesses. It ranges from 1.0 to 1.7 and is defined as $R_o = R_{size}R_{\phi}R_{yield}R_{sh}R_{mech}$ where, respectively, these factors represent the overstrength arising from the size of the selected member, the resistance factor used in design, the difference between real and specified material strength, the strain hardening observed in the behaviour of the material, and the additional resistance that a redundant structure possesses before a collapse mechanism is formed. Mitchell et al. do not, however, make a recommendation on what R values to use for the design of cold-formed steel structures.

AISI S213-07, the North American Standard for Cold-Formed Steel Framing – Lateral Design, is a new standard developed by the American Iron and Steel Institute (AISI). This standard can be used in the United States, Canada and Mexico and it contains provisions addressing the design of the lateral force

resisting system of CFS framed structures. The standard requires the straps in a concentrically braced frame to yield before fracture of the net section; thus a capacity design philosophy must be implemented. Also, AISI S213-07 lists the following seismic force modification factors and building height limits for use with the 2005 NBCC: for buildings with a SFRS detailed for ductile seismic performance (limited ductility concentrically braced frames (CBF)) $R_d = 2.0$ and $R_o = 1.3$ and a maximum storey height of 20 m, and for those with a SFRS that is not detailed for ductile seismic performance (conventional construction) $R_d = 1.25$ and $R_o = 1.3$ and a maximum storey height of 15 m when $I_E F_a S_d(0.2) < 0.35$. Conventional construction CBF systems at sites having $I_E F_a S_d(0.2) \geq 0.35$ are not permitted. Note, I_E , F_a and $S_d(0.2)$ are the earthquake importance factor, acceleration based site coefficient, and 5% damped spectral response acceleration for a period of $T=0.2$ s, respectively, as defined in the NBCC.

The US Army Corps of Engineers TI 809-07 Technical Instructions (2003) may also be used for the design of CFS framing. TI 809-07 recommends an R value of 4.0 (for use with American codes; which corresponds to the product of R_d and R_o from the 2005 NBCC) for strap braced walls and requires the use of a capacity design approach. The R value for cold-formed steel CBFs found in ASCE 7 (2005) is also 4.0.

Vamvatsikos and Cornell (2002) present a method called Incremental Dynamic Analysis (IDA) which allows for the evaluation of the structural performance of a building under seismic loads. A structural non-linear model of a building is subjected to a suite of earthquake time histories, all scaled to several levels of intensity. The end result is an IDA curve which gives the maximum response of the structure at each level of intensity. This allows for the collapse intensity of each scaled earthquake to be defined. Because the IDA curves are obtained from a non-linear dynamic analysis, they can be used for the evaluation of force modification factors and are the basis of performance-based earthquake engineering.

The ATC-63 Project (2008) provides a methodology for the determination of seismic performance factors for new structural systems in such a way that buildings with different SFRSs will have the same margin of safety against collapse in an earthquake. This method requires a representative nonlinear model of the behaviour of the evaluated SFRS. After dynamic analyses of the building model with real or simulated ground motion time histories and detailed incremental dynamic analyses a collapse fragility curve can be built. This fragility curve can then be adjusted for modeling uncertainty; ultimately an evaluation of the seismic performance factors and design method can be made.

Atkinson (2008) used the stochastic finite-fault method to generate simulated earthquake records that match the uniform hazard spectrum (UHS) for Canadian cities at a 2% probability of exceedance in 50 years, as is required by the 2005 NBCC. These representative earthquake records are required when nonlinear dynamic analysis is used. A common practice when the deaggregation of the seismic hazard at the site is available is to use a real ground motion record having similar magnitude, distance and site conditions. Once the earthquake records have been selected scaling or spectrum matching techniques can be applied to improve the match of the real record to the target linear response spectrum over a selected period range. When time histories of real earthquakes with desired characteristics are not available simulated records can be used. In this case Atkinson recommends selecting one low and one high magnitude earthquake: the first to match the low-period end (0.1 to 0.5s) and the second to match the high-period end (0.5 to 4s) of the target response spectrum. Also, more than one combination of low and high magnitude earthquake scenario should be considered and the selected simulated earthquake time histories should be scaled to match the UHS.

Pastor and Rodríguez-Ferran (2005) developed a differential model of the hysteretic behaviour of X-braced cold-formed steel frames. The model assumed that under lateral loading only braces will enter into the plastic range and dissipate energy while all other elements of the frame will remain in the elastic range. The

model is suitable only for unsheathed walls because it neglects the lateral stiffness of the cladding. Also, the model takes into account the extreme pinching, slackness and strain hardening observed during tests and can be used to obtain the seismic force modification factors used in the seismic design of structures. The authors concluded that the reversed cyclic behaviour of cross braced walls can be accurately predicted from the model.

Kim et al. (2007) attempted to match the test results obtained from a previous shake table test of a two-storey cold-formed steel braced wall panel (Kim et al., 2006) using the computer program for static and dynamic analysis DRAIN-2DX (Prakash et al., 1993). Columns and straps were modeled as “No. 2 – Plastic Hinge Beam-Column Element” and “No.1 – Inelastic Truss Bar Element”, respectively. It was reported that unintentional shaketable rocking motions caused by the large overturning moment was observed during tests. The authors concluded that a simpler model using truss elements can represent very well the performance of a CFS strap braced structure. Also, comparing the results from the model with and without base springs, it was pointed out that in order to estimate the fundamental frequency of the structure, which is the most important parameter in the dynamic analysis, the soil-structure interaction should be taken into account.

1.5.3 Conclusions

The research and design information summarized above was incorporated in the definition of the method used to design the test walls and for the dynamic analyses described in this thesis. First of all, the capacity design approach used by Al-Kharat and Rogers (2008) and required by AISI S213-07 (2007) was used for the design of all wall elements of the seismic force resisting system. Secondly, the determination of seismic force modification factors for CFS strap braced walls based on test results followed the procedure described by Mitchell et al. (2003). Also, to verify the current values of R_d and R_o and the height limits listed in AISI

S213-07 (2007), the methodology presented in the ATC-63 Project (2008) was adopted; as well, IDA analyses (Vamvatsikos and Cornell, 2002), which are the basis of the methodology in ATC-63 Project (2008), were performed. Finally, for the non-linear dynamic analyses the recommendations and generated earthquake records by Atkinson (2008) were used.

Chapter 2 Test Program

During the summer of 2007 thirty screw connected cold-formed steel strap braced wall specimens were tested in the Jamieson Structures Laboratory at McGill University, using a testing frame designed specifically for in-plane shear loading. All walls were 2440 x 2440 mm (8'x 8') in size with X-strap braces installed as shown in Figure 2.1.



Figure 2.1 Strap braced wall specimen 46A-C in test frame

The initial brace size for each wall was selected assuming factored in-plane lateral loads and using the factored tension resistance as found in the CSA S136 Specification (2007). The walls designed using these lateral loads are referred to as light, medium and heavy. All braced walls were then specifically designed and detailed following a capacity approach as required by AISI S213 (2007) (Section 2.1). The strap braces were expected to undergo gross cross-section yielding along their length, while the other elements in the seismic force resisting system were selected to be able to carry the probable brace capacity. A listing of all test specimens with details of all member components is provided in Table 2.1.

Table 2.1 Matrix of strap braced wall test specimens

Specimen Properties	Test Specimens					
	Light		Medium		Heavy	
Test Protocol	Monotonic	Cyclic	Monotonic	Cyclic	Monotonic	Cyclic
Reduced Braces, Short Fuse	25A-M ^d	26A-C	27A-M ^d	28A-C	29A-M ^d	30A-C
Reduced Braces, Long Fuse	31A-M ^d	32A-C	-	-	33A-M ^d	34A-C
Regular Braces	35A-M 41A-M ^c	36A-C 42A-C ^c	[9C-M] ^a 39A-M ^a 47A-M ^b	40A-C ^a 48A-C ^b	37A-M 43A-M ^c 45A-M ^a	38A-C 44A-C ^c 46A-C ^a
Strap Bracing (X-brace on both sides of wall)						
Thickness, in (mm)	0.043 (1.09)		0.054 (1.37) [0.043 (1.09)]		0.068 (1.73)	
Width, in (mm)	2.5 (63.5)		2.75 (69.9) [5 (127)]		4 (101.6)	
Fuse Width, in (mm) ^e	2.5 (63.5)		2.75 (69.9) [5 (127)]		4 (101.6)	
End Width, in (mm) ^e	3.75 (95.2)		4.25 (108)		6 (152.4)	
Grade, ksi (MPa)	33 (230)		50 (340) [33 (230)]		50 (340)	
Chord Studs (Double studs screwed together back-to-back)						
Thickness, in (mm)	0.043 (1.09)		0.054 (1.37)		0.068 (1.73)	
Dimensions, in (mm)	3-5/8x1-5/8-1/2 (92.1x41x12.7)		6x1-5/8x1/2 (152x41x12.7)		6x1-5/8x1/2 (152x41x12.7)	
Grade, ksi (MPa)	33 (230)		50 (340)		50 (340)	
Interior Studs						
Thickness, in (mm)	0.043 (1.09)		0.043 (1.09)		0.043 (1.09)	
Dimensions, in (mm)	3-5/8x1-5/8x1/2 (92.1x41x12.7)		6x1-5/8x1/2 (152x41x12.7)		6x1-5/8x1/2 (152x41x12.7)	
Grade, ksi (MPa)	33 (230)		33 (230)		33 (230)	
Tracks						
Thickness, in (mm)	0.043 (1.09)		0.054 (1.37)		0.068 (1.73)	
Dimensions, in (mm)	3-5/8x1-1/4 (92.1x31.8)		6x1-1/4 (152x31.8)		6x1-1/4 (152x31.8)	
Grade, ksi (MPa)	33 (230)		50 (340)		50 (340)	
Gusset Plates						
Thickness, in (mm)	NA		0.054 (1.37)		0.068 (1.73)	
Dimensions, in (mm)	NA		9x7 (229x179) [10x10 (254x254)]		10x8.5 (254x216)	
Grade, ksi (MPa)	NA		50 (340) [33 (230)]		50 (340)	

^a constructed with reinforced tracks, ^b X-brace on one side of wall, ^c constructed with U-shaped holddown, ^d two tests of this configuration carried out the second of which had additional screws placed along the length of the braces,

^e specimens with reduced width braces

In order to evaluate the inelastic behaviour of cold-formed steel (CFS) strap braced walls, specimens with regular, short fuse and long fuse braces were fabricated using a TRUMPF 2D flatbed laser cutting machine and tested. The braces used in the tests are shown in Figure 2.2.

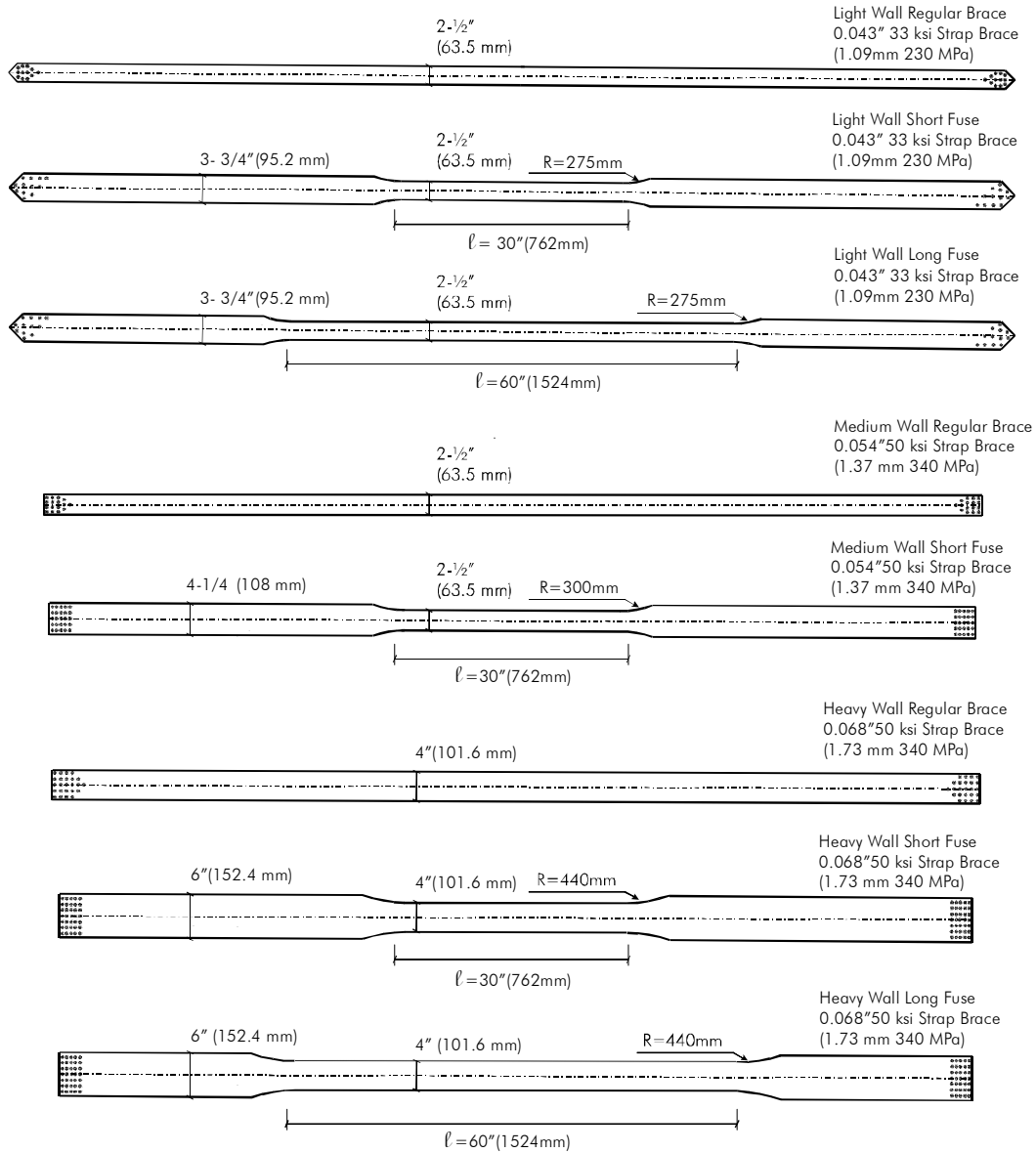

Figure 2.2 Schematic drawings of strap braces

Chord studs were connected back-to-back using No.10 x 3/4" (19 mm) wafer head self drilling / self tapping screws. The interior studs were placed at a nominal spacing of 406 mm (16"). All connections between the studs and tracks were made with No. 8 x 1/2" (12.7 mm) wafer head self drilling / self tapping screws.

The strap braces were connected to the chord studs or gusset plates with No. 10 x 3/4" (19 mm) wafer head self drilling / self tapping screws. The gusset plates were also connected to the framing members using the same No. 10 screws.

A bridging channel 0.043" x 1-1/2" x 1/2" (1.09 x 38 x 12.7 mm) was installed through the web knockouts at the mid-height of the walls in order to reduce the unbraced length of chord and interior studs. It was connected to a bridging clip at each stud with two No. 8 x 1/2" (12.7 mm) wafer head self drilling / self tapping screws; the clip was connected to the stud web also using two No. 8 screws.

Top tracks 2440 mm (8') in length were drilled to accommodate ten shear anchors and two anchor rods, whereas the 2743 mm (9') long tracks had holes for 12 shear anchors and two anchor rods. The top tracks were connected through a 25.4 mm thick aluminium spacer to the loading beam. Similarly, the 2440 mm (8') long bottom tracks contained six shear anchors and two holddown anchors, while the 2743 mm (9') long tracks had ten shear anchors and two holddown anchor rods. The base of the wall was attached to the testing frame through an aluminium spacer plate similar to that at the wall top. The function of the top shear anchors was to uniformly transfer the load from the loading beam to the top track; whereas the bottom shear anchors were installed to connect the wall to the testing frame in a more realistic fashion. The tension straps were painted with a hydrated lime solution (calcium hydroxide) in order to show the progression of yielding throughout the test. Additional information on connections and anchorages for each of the wall configurations may be found in Sections 2.2 – 2.4.

The testing frame was equipped with a 250 kN (55 kip) dynamic actuator with a stroke of ±125 mm (5"). Displacement controlled monotonic and reversed cyclic CUREE (*ASTM E2126; Krawinkler et al. 2005*) protocols were used in testing. The testing frame incorporates external beams to prevent out-of-plane displacement of the wall specimen, such that only lateral in-plane displacement takes place, as shown in Figure 2.3. Measurements consisted of top wall

displacements, strains in the steel straps, acceleration of the loading beam assembly, the shear load at the wall top, the slip and uplift at the base of the wall, as well as the uplift force in the holddown anchor rods. The LVDTs, strain gauges, load cells and accelerometer were connected to Vishay Model 5100B scanners, which were used to record data using the Vishay System 5000 StrainSmart software. Additional information on the test assembly and instrumentation may be found in Section 2.5.

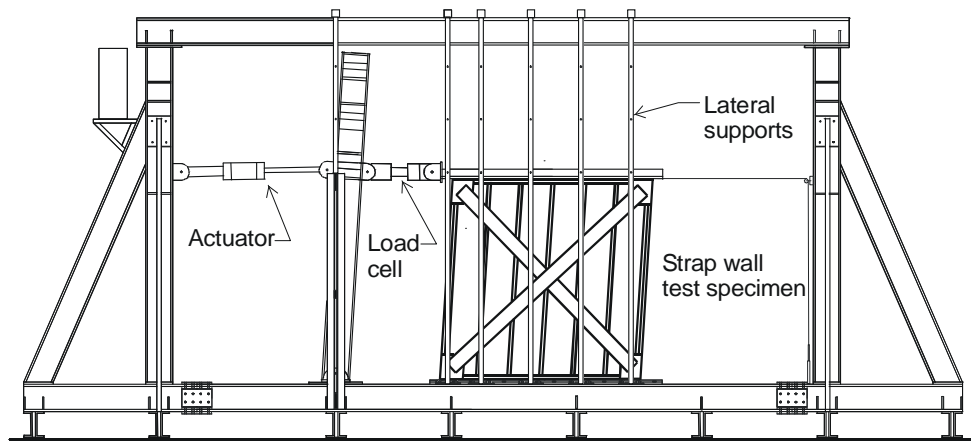

Figure 2.3 Schematic of strap braced wall specimen in test frame

2.1 CAPACITY DESIGN APPROACH

In the first phase of the project during the summer of 2004 sixteen strap braced wall specimens were tested in the Jamieson Structures Laboratory at McGill University. These walls were not designed following a capacity design approach. The light walls failed for the most part by yielding of the strap braces; however, the medium and heavy walls failed because some elements in the load carrying path were seriously damaged before the predicted yield load was reached or fracture of a brace occurred at low deformation levels (*Al-Kharat and Rogers, 2005, 2007*).

In the second phase of the project during the summer of 2005 fifteen wall specimens were fabricated and tested. These specimens were detailed following

seismic capacity design principles that were based on the requirements found for hot rolled steel design in CSA S16. The expected failure mode was gross cross-section yielding of the braces. Test results showed that walls with an extended track generally failed by yielding of straps while walls with a regular track failed in compression or bearing failure of the track. Note, the regular length tracks for these tests did not meet the capacity design requirement of being able to carry the probable brace force at yielding. However, two wall specimens with extended tracks failed by net section fracture of the braces during the reversed cyclic test (*Al-Kharat and Rogers, 2006, 2008*). This research led to the development of a capacity design approach that was included in the latest version of the AISI North American Lateral Design Standard AISI S213 (*AISI, 2007*) (See Section 1.3).

In the current phase of the project in order to avoid the net cross-section failure of braces that can lead to inadequate ductility, and compression and bearing failure of tracks, wall configurations with flat straps having a reduced width fuse and specimens with reinforced tracks were developed, respectively. All strap braced walls were specifically designed and detailed following a capacity approach as found in AISI S213 (*AISI, 2007*). In this approach an element that is part of the seismic force resisting system (SFRS) is chosen as a fuse element; the remaining elements are designed and detailed to carry the probable capacity of the fuse. In a braced wall the straps are typically expected to yield during a design level earthquake. In order to dissipate earthquake energy these braces should be able to reach and maintain their yield strength during repeated deformation cycles. Other elements in the SFRS, such as the chords, tracks, screw connections, holddowns, anchor rods, shear anchors and foundation must be designed for the probable capacity of the braces. This section describes the design procedure for the SFRS of the wall test specimens.

2.1.1 Design of regular and fuse braces

The three brace sizes were first selected given the assumed factored loads of 20 kN (light), 40 kN (medium) and 75 kN (heavy) that represent loads obtained from the lateral wind or seismic forces calculated according to the applicable building code. The three load levels were chosen to represent the range of possible strap braced walls that would commonly be constructed. To determine the regular brace sizes (Table 2.1) the factored tension resistance based on gross cross-section yielding (Equation 2.1) and net cross-section fracture (Equation 2.2) (*CSA S136, 2007*) were used.

$$T_r = \phi_t A_g F_y \quad (2.1)$$

$$T_r = \phi_u A_n F_u \quad (2.2)$$

where $\phi_t = 0.9$ is the resistance factor for gross section yielding, $\phi_u = 0.75$ is the resistance factor for net section fracture, A_g is the gross area of the brace, A_n is the net area of the brace, F_y is the yield strength, and F_u is the tensile strength. Once the width and thickness of the braces had been selected, the probable tensile capacity T_n of the diagonal strap members with constant width was determined from Equation 2.3, which is given in *AISI S213-07*.

$$T_n = A_g R_y F_y \quad (2.3)$$

where $R_y = 1.5$ for 33 ksi (230 MPa) ASTM A653 steels, $R_y = 1.1$ for 50 ksi (340 MPa) ASTM A653 steels (*AISI S213-07*); this factor is used to obtain a realistic estimate of the brace force at yielding.

The fuse area of a brace with reduced cross-section width was determined following the procedure for regular braces explained above. After the fuse width and thickness have been selected, the length of the reduced fuse segment (Figure 2.2) was determined from Equation 2.4.

$$l \geq \frac{\Delta \cos \alpha}{\varepsilon} \quad (2.4)$$

where Δ is the maximum expected drift, ε is the minimum elongation, α is the angle of straps with the respect to horizontal. For the design of all test specimens with short fuses the maximum displacement of the actuator $\Delta = 120$ mm (4.9% drift) was used. In a real design situation the maximum inelastic drift limit of 2.5% in the NBCC could be taken. ASTM A653 lists the minimum elongation in 50 mm (2") for Structural Steel (SS) 33 with minimum yield strength 33 ksi (230 MPa) as $\varepsilon = 20\%$, and for Structural Steel (SS) 50 Class 1 with minimum yield strength 50 ksi (340 MPa) as $\varepsilon = 12\%$. Because there was no available research data for strap braced walls, and in order to compare the results from different tests $\varepsilon = 12\%$ was accepted for all specimens and the fuse length was determined to be $l = 762$ mm (30"). Also, walls with a 1524 mm (60") fuse were designed and tested to investigate any possible change in behaviour and failure modes due to a longer fuse section. In order to allow for a gradual flow of stress from the full cross-sectional area to the reduced width portion of the brace a transition curve with a radius of $R = 4.3b$ was used, where b is the width of the reduced cross-section area. This radius R (Figure 2.4) was chosen based on the standard coupon sizes given in ASTM A370 (2002).

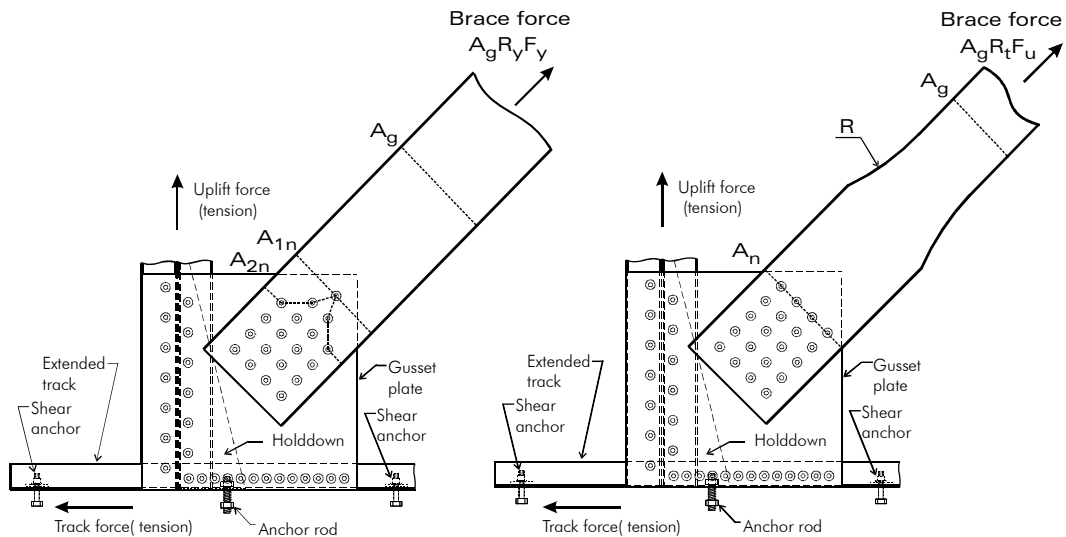

Figure 2.4 Corner detail of a wall with regular and fused braces

To account for the possibility of strain hardening in the reduced width fuse braces, due to the short length of the fuse, the probable ultimate capacity of the braces T_u (Equation 2.5) was used to conservatively calculate the design forces in the other SFRS components.

$$T_u = A_g R_t F_u \quad (2.5)$$

where $R_t = 1.2$ for 33 ksi (230 MPa) ASTM A653 steels, $R_t = 1.1$ for 50 ksi (340 MPa) ASTM A653 steels (*AISI S213-07*); this factor is used to obtain a realistic estimate of the ultimate capacity of the brace. Equation 2.5 is similar in format to Equation 2.3, but instead of R_y and F_y , R_t and F_u were used because the fuse length was based on the elongation when the maximum tensile strength F_u is reached. This is a conservative approach; a more accurate estimate of the force in the brace at the expected inelastic displacement could be obtained using a FE model of the wall and brace that accounts for the strain hardening behaviour of the various sections. The values of T_n and T_u for the various wall configurations are listed in Table 2.2.

Table 2.2 Expected forces in SFRS due to brace yielding and brace fracture

Force ^c	Test Specimens					
	Light		Medium		Heavy	
	Regular Braces	Fuse Braces	Regular Braces	Fuse Braces	Regular Braces	Fuse Braces
	35A-M, 36A-C 41A-M, 42A-C	25A-M, 26A-C 31A-M, 32A-C	39A-M, 40A-C 47A-M ^b , 48A-C ^b [9C-M]	27A-M, 28A-C	37A-M, 38A-C 43A-M, 44A-C 45A-M, 46A-C	29A-M, 30A-C 33A-M, 34A-C
$T_n = A_g R_y F_y$ Single Brace, kN (kips)	23.9 (5.4)	-	35.8 (8.0) [47.7 (10.7)]	-	65.7 (14.8)	-
$T_u = A_g R_t F_u$ Single Brace, kN(kips)	-	25.7 (5.8)	-	47.4 (10.7)	-	87.0 (19.6)
Total Lateral Force, kN (kips) ^d	33.8 (7.6)	36.3 (8.2)	50.6 (11.4) [67.4 (15.1)]	67.0 (15.1)	92.9 (20.9)	123.0 (27.7)
Total Vertical Force, kN (kips) ^d	33.8 (7.6)	36.3 (8.2)	50.6 (11.4) [67.4 (15.1)]	67.0 (15.1)	92.9 (20.9)	123.0 (27.7)

^a Total force based on expected capacity of two braces, ^b X-brace on one side of wall, total lateral and vertical force are half of the presented values,

^c Material properties and brace sizes are given in Table 2.1

A comparison between the lateral resistance of identical walls with regular and short fused braces is shown in Figure 2.5. As can be seen severe strain hardening was observed in the walls with fused braces which justifies the use of T_u instead of T_n in the design of the SFRS elements. Also, it can be noted that the walls with

fused braces have higher elastic stiffness in comparison with the walls with regular braces due to the larger cross-sectional area outside of the fuse length.

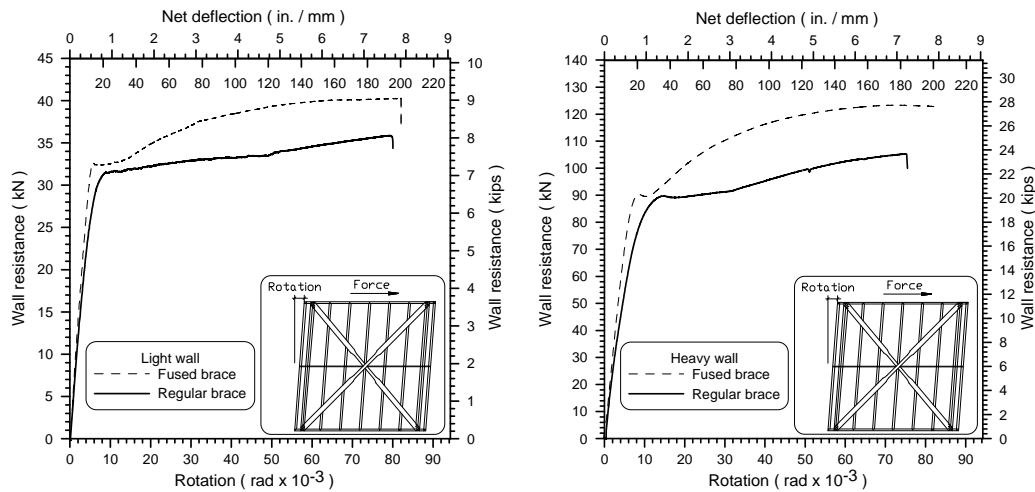

Figure 2.5 Monotonic resistance light and heavy strap braced walls

Once T_n and T_u were determined for the walls with regular and fused braces, respectively, all remaining elements in the SFRS (brace connections, chord studs, track, anchor rods, holddowns and shear anchors) were designed for this expected tension force, and its associated vertical and horizontal components (Figure 2.4).

2.1.2 Design of chord studs

Chord studs composed of back-to-back (screw connected) C-sections were designed for the vertical component of the probable brace force (Table 2.2) as a concentric compression member following CSA S136 (2007). As found in AISI S213 (2007) the nominal axial capacity, i.e. $\phi_c = 1.0$, was used (Table 2.3). In the design of a building the gravity loads which form part of the load combination would also need to be included. Since in the case of the test walls no gravity load was applied this additional force was not considered. Effective length factors $K_x = 0.9$, $K_y = 0.9$ were based on the results of chord stud axial tests by Hikita (2006), who found that the chord studs could carry a slightly higher force than that associated with a pin ended column; $K_t = 1.0$ was used for torsional buckling. The unbraced length in the strong axis was taken as the full wall height 2440 mm (8’);

for the weak axis and torsion half of the wall height 1220 mm (4') was considered because the buckling length was restrained by the continuous bridging at the mid-height of the wall. Calculations were carried out assuming the two C-sections were connected at 305 mm o/c, both with and without web perforations.

Table 2.3 Nominal Axial compression resistance of back-to back chord studs

Calculation Assumptions ^a	Test Specimens		
	Light	Medium	Heavy
	25A-M, 26A-C 31A-M, 32A-C 35A-M, 36A-C 41A-M, 42A-C	9C-M 27A-M, 28A-C 39A-M, 40A-C 47A-M, 48A-C	29A-M, 30A-C 33A-M, 34A-C 37A-M, 38A-C 43A-M, 44A-C 45A-M, 46A-C
kN (kips)	kN (kips)	kN (kips)	
Web connections at 305 mm o/c and web holes not considered	67.1 (15.1)	118.0 (26.5)	159.2 (35.8)
Web connections at 305 mm o/c and web holes not considered	58.7 (13.2)	102.8 (23.1)	136.3 (30.6)

^aMaterial properties and chord stud sizes are given in Table 2.1

2.1.3 Design of screw connections

The design of screw connections for the braces and gusset plates followed the CSA S136 Specification (2007) provisions for shear capacities provided by the manufacturer. The factored resistance of a screw connection was determined from Equation 2.6.

$$P_r = \phi P_{ss} \quad (2.6)$$

where $\phi = 0.4$ and for No. 10 screws $P_{ss} = 5.36$ kN (1.09mm steel), 5.64 kN (1.37mm steel), and 6.90 kN (1.73mm steel). The factored resistance of the screws was used in design, as required by AISI S213 (2007), because of the critical nature of these brace connections. P_{ss} is the nominal shear capacity for a single screw specified by the manufacturer; it accounts for the possibility of screw shear, bearing of the sheet steel and tilting of the fastener. The number of required screw fasteners for the brace connections was obtained from Equation 2.7.

$$n = \frac{P}{P_r} \quad (2.7)$$

where $P = T_n$ for walls with regular braces, and $P = T_u$ for walls with reduced width braces.

It was also necessary to ensure that the braces did not fail by fracture at the connection. The positioning and spacing of the screws were selected such that the nominal net section tension capacity at the connection exceeded the probable yield capacity T_n (Equation 2.8) or the probable ultimate capacity T_u (Equation 2.9) for the regular or fused braces, respectively.

$$A_n R_t F_u \geq A_g R_y F_y = T_n \quad (2.8)$$

$$A_n R_t F_u \geq A_g R_t F_u = T_u \quad (2.9)$$

Equation 2.8 can be found in AISI S213-07; it insures that gross cross section yielding of the braces takes place prior to net cross section fracture at the connection, or at any perforation in the cross section (see Figure 2.4). Equation 2.9 was used in the design of the walls with fuse braces; it is a modified version of Equation 2.8 but instead of the probable yield strength $R_y F_y$ it uses the probable ultimate strength of the brace because severe strain hardening was observed during tests (Figure 2.5). For the walls with a fuse section Equation 2.9 is easily satisfied, allowing for a square pattern of screws to be used. For the walls with an unreduced cross section a triangular pattern of screws was normally used, similar to Al-Kharat and Rogers (2008) to meet the requirements of Equation 2.8. Also, the spacing of the screws meets the requirements of CSA S136 (2007) for minimum edge distance of $1.5d$ and minimum centre-to-centre distance of $3d$, where d is the diameter of a screw. The details of screw placement for the braces are given in Sections 2.3 and 2.4 and a summary of the screw connection tests is presented in Appendix F.

2.1.4 Design of gusset plates

Braces were connected directly to the chord and track flanges of the light walls, whereas, a gusset plate was installed between the frame and strap in the medium and heavy walls. These more highly loaded walls required substantially more

screw fasteners at the brace connections which could not easily be placed directly into the studs and track Figure 2.6.

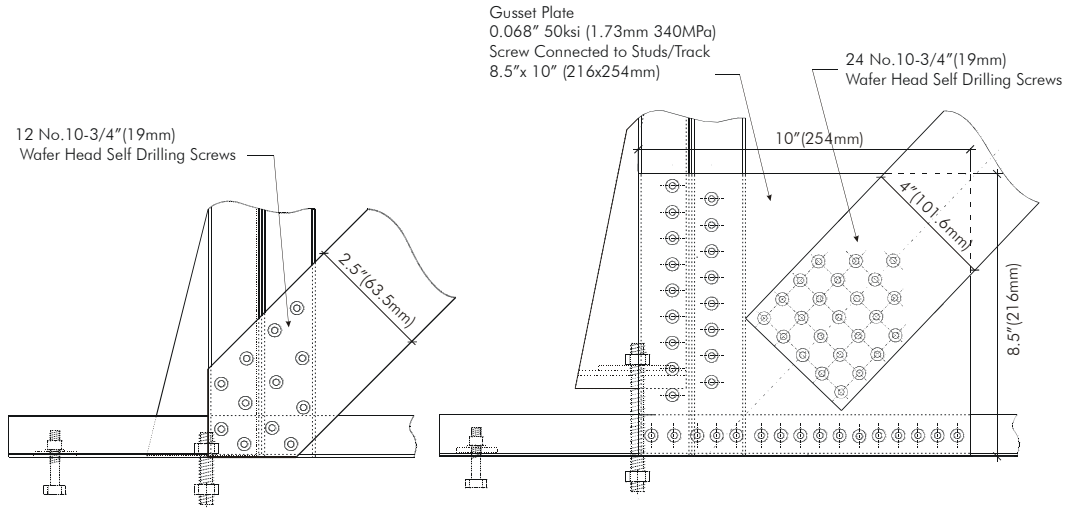

Figure 2.6 Corner details light and medium walls

The gusset plate also allowed for a more direct connection to the track such that horizontal brace force could be transferred into the frame. The number of screws connecting the gusset plates to the chord and track flanges was determined using the conservative assumption that the vertically placed screws carry the vertical component of the expected brace force, and the horizontal screws carry the horizontal component. Overall dimensions of the gusset plates were selected after the fastener pattern was determined. The tension capacity of the gusset plates (Table 2.4) was calculated for the theoretically effective cross-sectional area at the end of a connection limited by the Whitmore section (*Whitmore 1952*) (Figure 2.7).

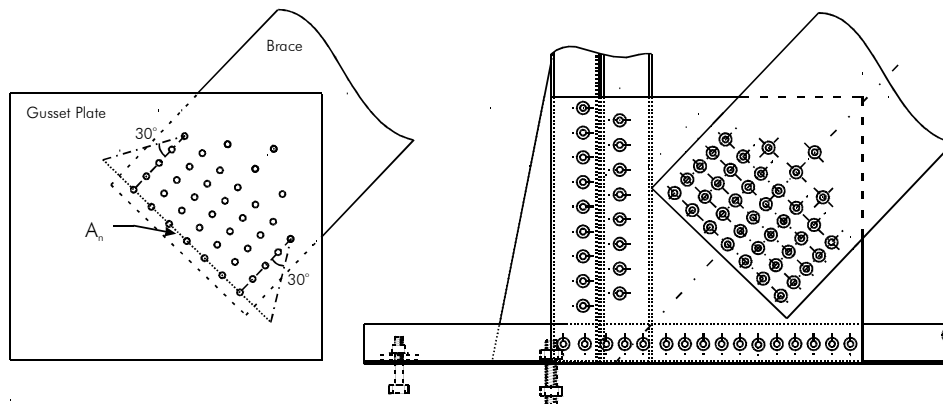

Figure 2.7 Whitmore section and a corner detail of a heavy wall

Since the braces do not carry any compression force the gussets were only designed for tension. The nominal capacity of the gusset plates was used, i.e. $\phi = 1.0$, as it is allowed by AISI S213-07 because the design level earthquake is a rare event with a return period of 1 in 2500 years. The details of screw placement for the gusset plates are given in Section 2.3 and 2.4.

Table 2.4 Axial tension resistance of gusset plates

Calculation Assumption ^a	Test Specimens							
	9C-M	27A-M 28A-C	29A-M 30A-C 33A-M 34A-C	37A-M 38A-C	39A-M 40A-C 47A-M 48A-C	41A-M 42A-C	43A-M 44A-C	45A-M 46A-C
	kN (kips)	kN (kips)	kN (kips)	kN (kips)	kN (kips)	kN (kips)	kN (kips)	kN (kips)
$A_g F_y$	51.8 (11.6)	69.4 (15.6)	111.2 (25.0)	88.7 (19.9)	44.5 (10.0)	37.4 (8.4)	126.1 (28.3)	90.4 (20.3)
$\phi A_g F_y$	46.6 (10.5)	62.4 (14.0)	100.1 (22.5)	79.9 (18.0)	40.1 (9.0)	33.7 (7.6)	113.5 (25.5)	81.4 (18.3)
$A_n F_n$	61.6 (13.8)	76.9 (17.3)	120.6 (27.1)	98.5 (22.1)	47.0 (10.6)	38.2 (8.6)	140.2 (31.5)	100.8 (22.7)
$\phi_u A_n F_n$	46.2 (10.4)	57.7 (13.0)	90.4 (20.3)	73.9 (16.6)	35.3 (7.9)	28.6 (6.4)	105.2 (23.7)	75.6 (17.0)

^aMaterial properties and gusset plate sizes are given in Table 2.1

2.1.5 Design of holddowns

Uplift forces were transferred from the chord studs to the test frame by holddown devices. Simpson Strong-Tie S/HD10S holddown with an allowable tension capacity of 11120 lb (49.5 kN) (*C-CFS06-R* © *Simpson Strong-Tie, 2007*) were used for the light walls. The medium and heavy walls were fitted with S/HD15S holddown with an allowable tension capacity of 13500 lb (60 kN) (*C-CFS06-R* © *Simpson Strong-Tie, 2007*). Although the expected vertical force in the chord studs for the heavy walls (Table 2.1) was significantly above the allowable tension capacity, the ultimate capacity 49143 lb (218.6 kN) for the Simpson Strong-Tie S/HD15S (*C-CFS06-R* © *Simpson Strong-Tie, 2007*) was approximately twice that required (Table 2.1). The holddowns of previous tests by Al-Kharat and Rogers (2006, 2008) were also selected with this approach; these past braced wall specimens did not exhibit any visible distress in the holddowns of the heavy walls during testing. It is recommended that the manufacturer should

be consulted prior to relying on the ultimate resistance of the holddowns in the capacity design procedure. ASTM A193-B7 (2006) grade steel threaded anchor rods 7/8" (22.2mm) for the light walls and 1" (25.4mm) for the medium and heavy walls were used to transfer the vertical component of the expected brace force from the holddowns to the test frame. Anchors rods were designed according to the CSA S16 Standard. Special U-shaped holddowns were used for specimens 41A-M, 42A-C, 43A-M and 44A-C. Details of these holddowns, which were fabricated in the lab, are presented in Figure 2.8 and Figure 2.9.

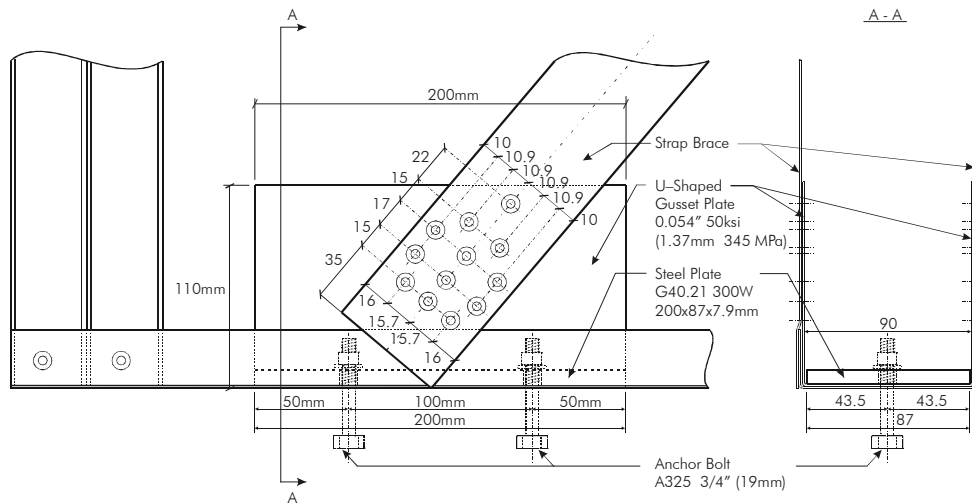

Figure 2.8 Details of the corner and U-shaped holddown of specimens 41A-M and 44A-C

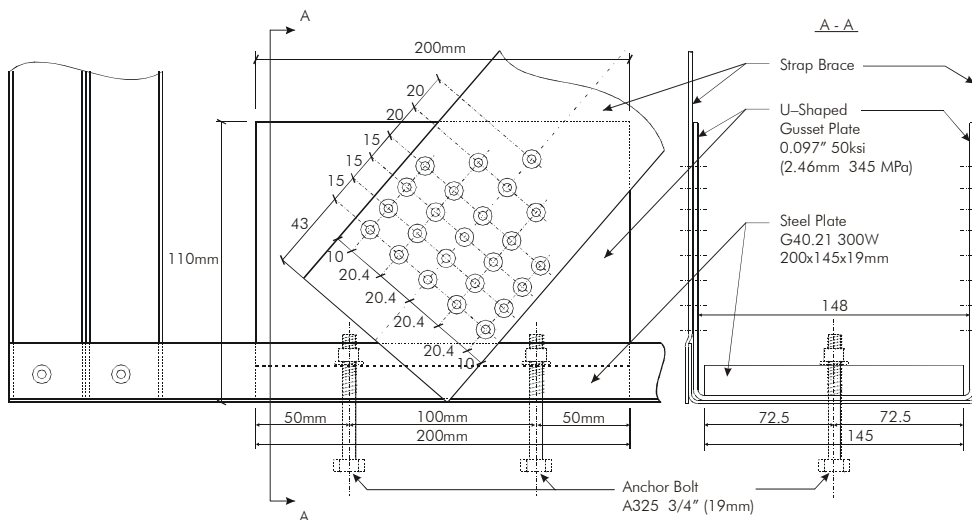

Figure 2.9 Details of the corner and U-shaped holddown of specimens 43A-M and 44A-C

The holddown consisted of a U-shaped cold-formed steel section and a thick steel plate that were placed in the track of a wall specimen. These two elements were connected with two anchors to the supporting structure. The anchors were relied on to carry both shear and uplift forces. The U-shaped section transferred the shear forces directly to the anchors, whereas the uplift forces were first transferred to the thicker steel plate through which the anchors were placed. Tension, bearing and shear were the failure modes considered for the design of the U-shaped section.

Tension capacity of gusset plates was considered adequate, because they were made of the same or thicker steel than the braces. If a designer decides to use thinner or lower grade steel for the U-shaped holddown, the procedure used for the design of the gussets plates (Section 2.1.4) can be followed.

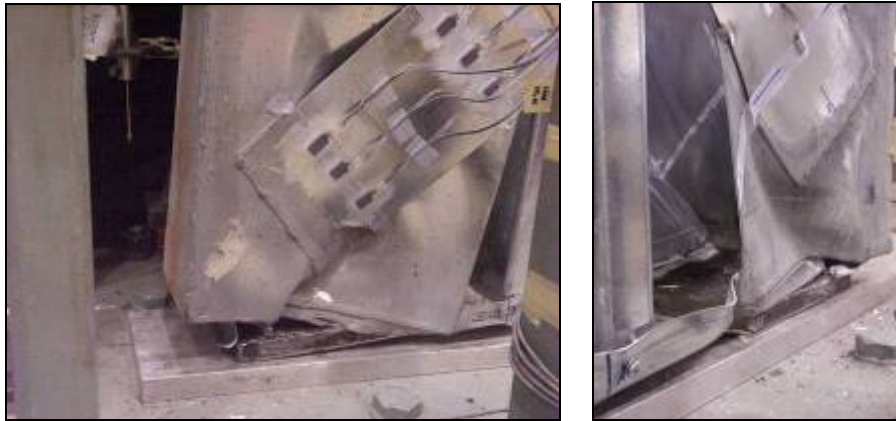

Figure 2.10 Punching shear failure mode (Al-Kharat and Rogers, 2005)

The shear capacity (shear yielding along the length of the U section – both sides) was considered because of the punching shear failure mode observed by Al-Kharat & Rogers (2005, 2007) (Figure 2.10). The shear strength of the steel U-section was assumed to be $0.6F_y$. For the test specimens 41A-M and 42A-C the nominal shear capacity of the 0.054” (1.37 mm) thick U sections was 55.9 kN (per side), and for specimens 43A-M and 44A-C the nominal shear capacity of the 0.097” (2.46 mm) thick U-sections was 132.8 kN (per side).

The nominal bearing capacity was determined according to CSA S136 (2007). The U-shaped holddown was designed as an inside sheet of a double shear connection because it was placed between the web of the track and the steel plate. For test specimens 41A-M and 42A-C the bearing capacity of the 0.054" (1.37 mm) thick U sections at the two $\frac{3}{4}$ " shear anchors was 61.1 kN, and for specimens 43A-M and 44A-C the total bearing capacity of the 0.097" (2.46 mm) thick U sections was 126.2 kN.

The steel plate was designed as a short cantilever (Figure 2.11) with a length of half the steel plate width and loaded at the free end with the vertical component of the expected brace force. Two anchor bolts A325 $\frac{3}{4}$ " (19 mm) were checked for combined shear and tension according to CSA S16; the maximum factored brace force that one bolt A325 $\frac{3}{4}$ " (19 mm) can carry was determined to be 97.4 kN.

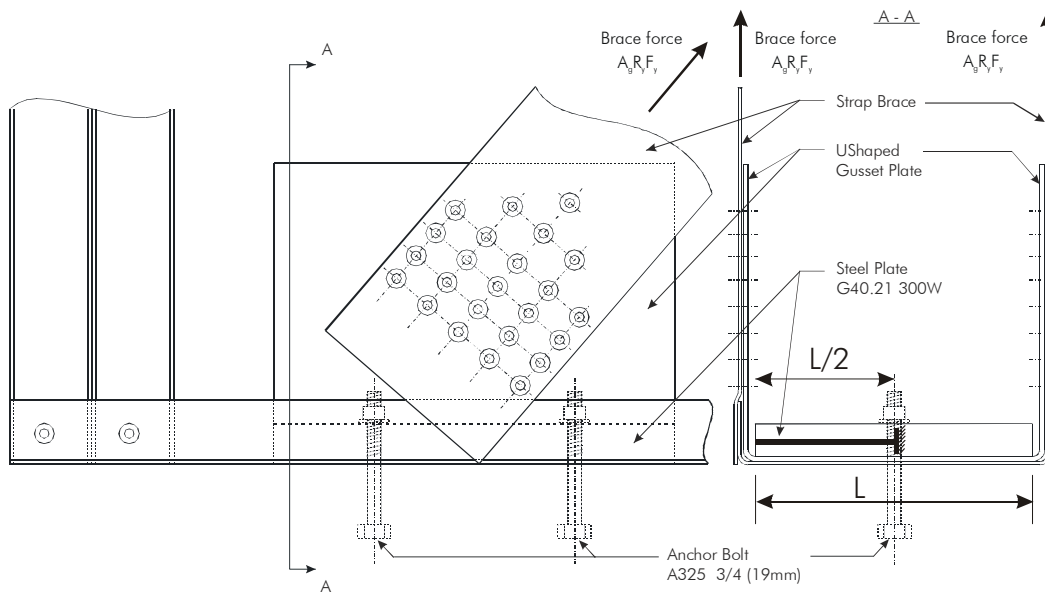

Figure 2.11 Design model for the steel plate

2.1.6 Design of tracks

The nominal axial tension, axial compression and bearing capacity of the tracks were determined following CSA S136. The axial tension and compression capacity of the tracks are given in Table 2.5, where the axial compression capacity was determined assuming that the track was fully braced over its length. The

thickness and grade of the track was selected to be the same as that used for the chord studs. Because of this choice the tracks did not have sufficient axial compression capacity to transfer the horizontal component of the probable brace force (Table 2.2) to the supporting structure. For this reason a reinforced or extended track detail was used (Figure 2.12). Walls for which the thickness of the track was increased, such that the horizontal brace force could be carried in compression, were tested by Comeau (2008).

Table 2.5 Nominal axial resistance of track sections

Calculation Assumption ^a	Test Specimens		
	light	medium	heavy
	kN (kips)	kN (kips)	kN (kips)
Axial compression capacity web holes not considered	23.8 (5.4)	48.1 (10.8)	73.9 (16.6)
Axial tension capacity web hole not considered	38.5 (8.6)	100.5 (22.5)	126.9 (28.5)
Axial tension capacity web hole 22 mm for shear anchor considered	44.5 (10.0)	119.5 (26.9)	150.8 (33.9)

^aMaterial properties and track sizes are given in Table 2.1

Reinforcement was provided by creating a box section by screw connecting a piece from the same C-section to the track Figure 2.13. It was assumed that the compression force in the track is equally distributed along its length to the shear anchors; therefore the axial compression load in the track will decrease at each anchor as one moves away from the base of the brace under load. The reinforcement was required only for the part of a track where the axial compression force was more than the nominal compression capacity of the single C-shape. Tests showed that reinforcement was effective when the first two stud spacings of a wall specimen were reinforced; this allowed the horizontal component of the brace force to be distributed amongst more shear anchors. The screws connecting two tracks were placed at the minimum distance $3d$ allowed by CSA S136. In order to determine the proper spacing between the screws one can assume that the total shear resistance of all screws connecting the tracks should exceed the compression force in the track. Also, maximum distance between the

screws should prevent the local buckling of the track flanges. In order to investigate the screw spacing and the behaviour of reinforced tracks more research is required. The details of the track reinforcement are given in Sections 2.3 and 2.4.

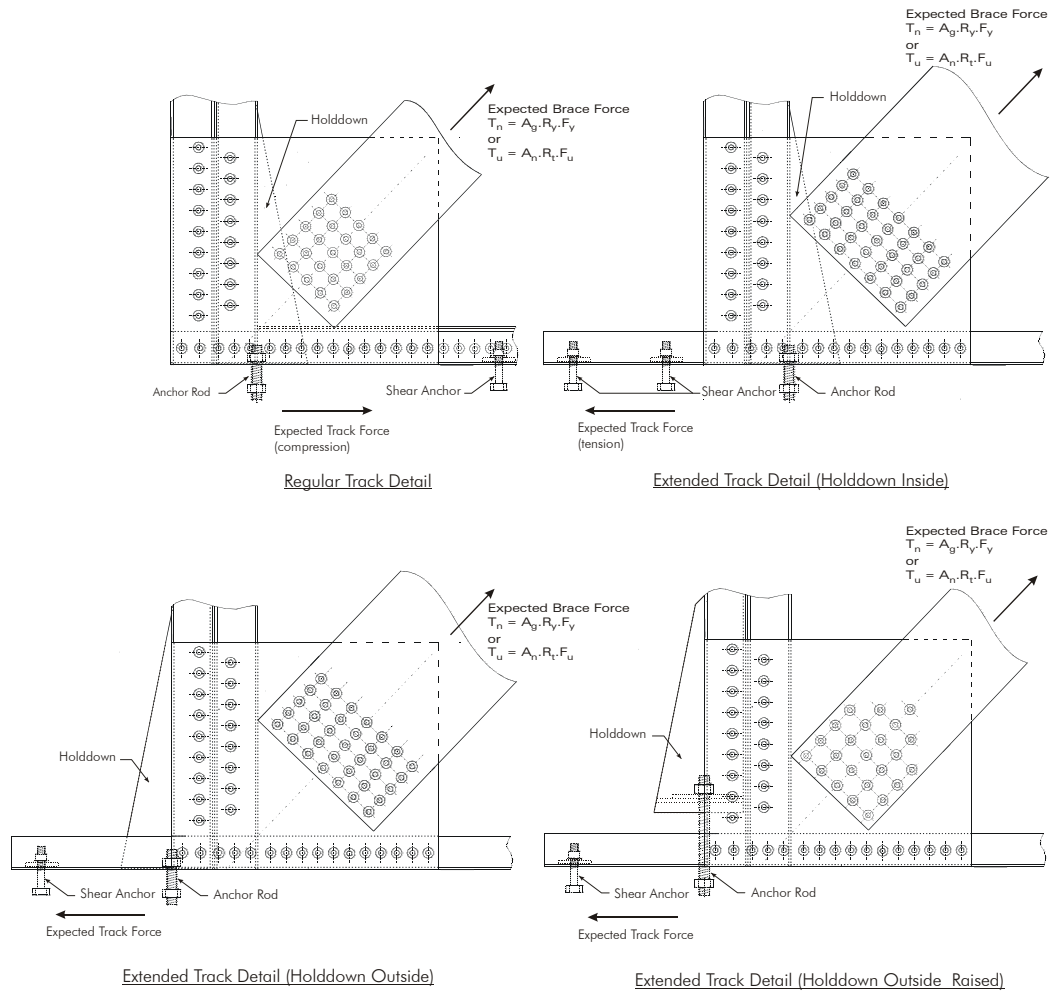

Figure 2.12 Track details showing track force



Figure 2.13 Reinforced track (left) vs. extended track with increased bearing resistance (right)

The wall configurations with the extended tracks were constructed with 2743 mm (9') long tracks instead of 2440 mm (8') long regular tracks. The 152 mm (6") part of the track (at each end) that was left outside of the wall footprint was connected to the supporting structure with one or two shear anchors depending on the required bearing resistance. In this case, it was assumed that the horizontal component of the expected brace force was carried through the extended part of the track by means of tension to the supporting foundation. Walls with the same detail were successfully tested by Al-Kharat and Rogers (2008). The axial tension capacity of the tracks (Table 2.5) was sufficient to resist the expected total lateral force (Table 2.2).

The three positions of holddowns for the walls with extended tracks are shown in Figure 2.12. The heavy wall with a holddown placed on the outside of the chords was constructed with only one shear anchor because there was not enough space in the extended part of the track to install a second anchor. This resulted in insufficient bearing capacity of the track. A steel plate 80x100 mm, 2.46 mm thick, 50ksi (340 MPa) was welded to the track to increase its bearing capacity (Figure 2.13). The bearing capacities of track sections are given in Table 2.6.

Table 2.6 Nominal bearing resistance of track sections

Calculation Assumptions ^a	Test Specimens			
	Light	Medium	Heavy	
	25A-M, 26A-C 31A-M, 32A-C 35A-M, 36A-C 41A-M, 42A-C	9C-M 27A-M, 28A-C 39A-M, 40A-C 47A-M, 48A-C	43A-M, 44A-C 45A-M, 46A-C	29A-M, 30A-C 33A-M, 34A-C 37A-M, 38A-C
kN (kips)	kN (kips)	kN (kips)	kN (kips)	
per shear anchor ^b	14.5 (3.2)	30.6 (6.9)	42.9 (9.6)	116.2 (26.1) ^c
per anchor rod	14.7 (3.3) ^c	33.5 (7.5) ^d	50.0 (11.2) ^d	

^aMaterial properties and track sizes are given in Table 2.1, ^b3/4"(19.1mm) diameter ASTM A325 bolt, ^c7/8"(22.2 mm) diameter ASTM A193 threaded anchor rod, ^d1"(25.4 mm) diameter ASTM A193 threaded anchor rod, ^eSteel plate 80x100 mm, 0.097" (2.46 mm) thick, 50ksi (340 MPa) was welded to the track in order to increase its bearing capacity

2.2 CONSTRUCTION DETAILS OF LIGHT TEST WALLS

Representative schematic drawings and corner details of light walls 25A-M, 26A-C, 31A-M, 32A-C, 35A-M, 36A-C, 41A-M and 42A-C are illustrated in Figures

2.14-2.17. Also, photographs of typical test specimens and brace connection and corner details are shown in Figure 2.14 to Figure 2.21.

Test specimens 25A-M, 26A-C, 31A-M, 32A-C, 35A-M and 36A-C were constructed with 2440 mm (9') long tracks; Simpson Strong-Tie S/HD10S holddowns were attached to the exterior side of the chord studs at each corner with 24 No.14-1"(25.4 mm) hex head self drilling screws. An ASTM A193-B7 7/8" (22.2 mm) threaded anchor rod was then installed to connect the wall to the test frame and loading beam as per the manufacturer's instructions. Test specimens 25A-M, 26A-C, and 31A-M, 32A-C were designed with a reduced cross-section width along a length of 762mm (30") and 1524mm (60"), respectively. The holddowns in specimens 35A-M and 36A-C were raised 50.8 mm (2") from the top of the track flange in order to evaluate the effect of not placing the holddowns flush with the bottom of the wall.

Test specimens 41A-M and 42A-C were constructed with 2440 mm (8") long tracks, and U-shaped holddowns. These were attached to the loading beam and the base of test frame with two 3/4" (19mm) diameter ASTM A325 bolts. Chord studs were connected to the top and bottom tracks with four No. 8-1/2 (12.7mm) wafer head self drilling screws on each side. Shear forces were transferred to the loading beam and to the base of test frame with 3/4" (19mm) diameter ASTM A325 bolts placed along the top and bottom tracks.

Additional No. 8 self drilling wafer head screws were used to attach the braces (in one direction) to the interior frame studs. This was done to evaluate the effect on the lateral resistance and ductility of each wall configuration. An extra index was added to a specimen's name, 1 for specimens where braces were not attached to the interior frame studs, and 2 for the specimens with braces screwed to the interior framing studs.

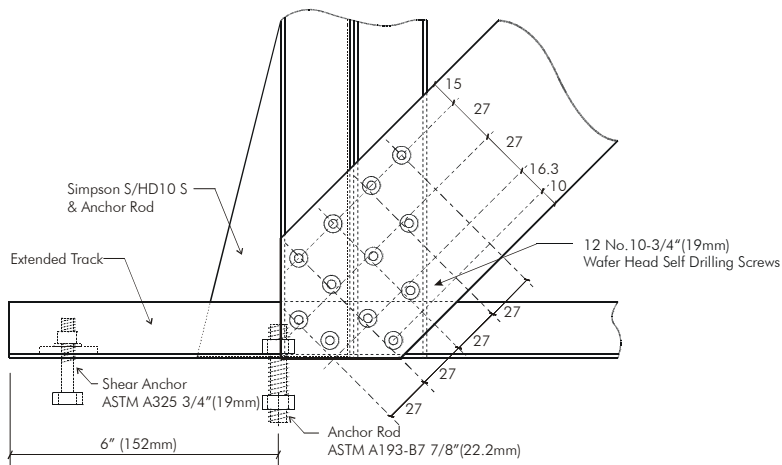
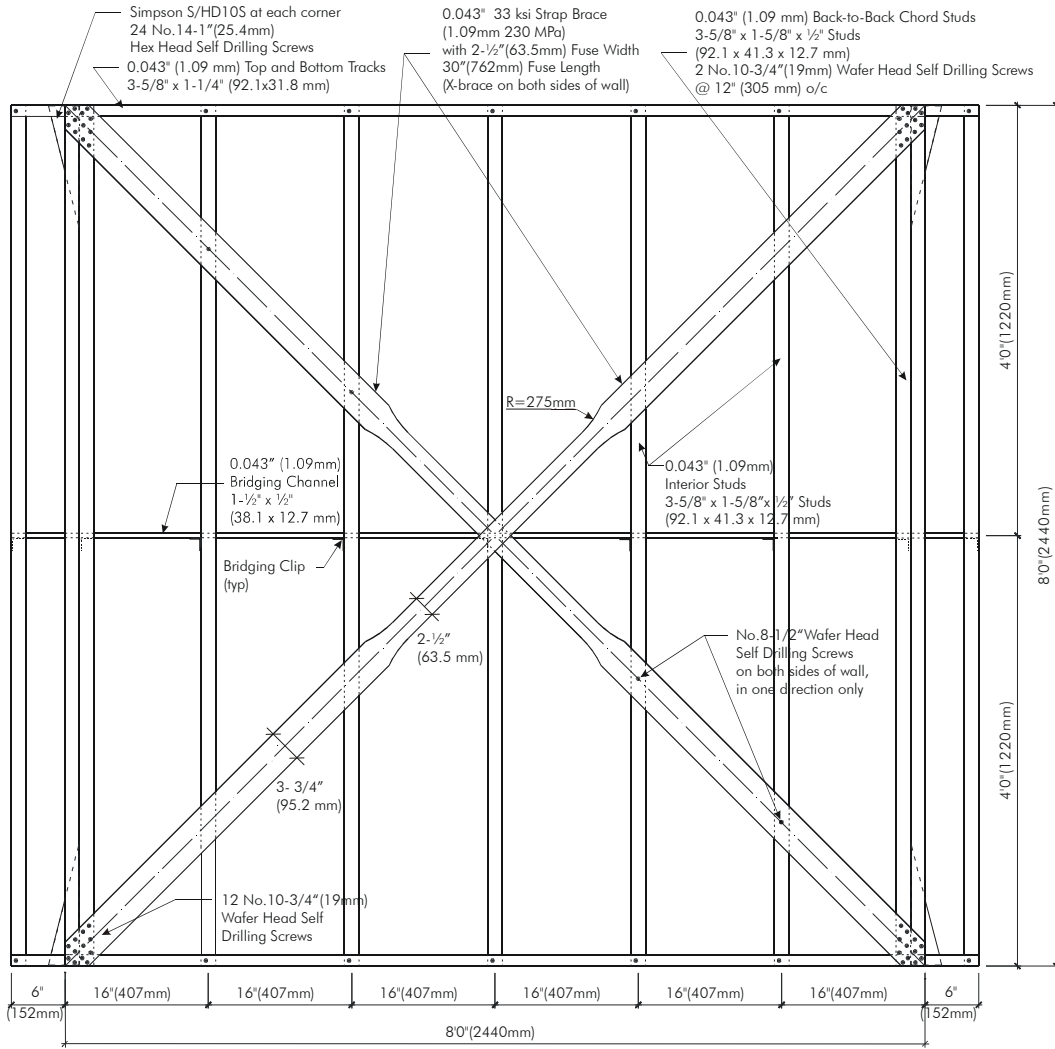

Figure 2.14 Nominal dimensions and the corner detail of specimens 25A-M and 26A-C

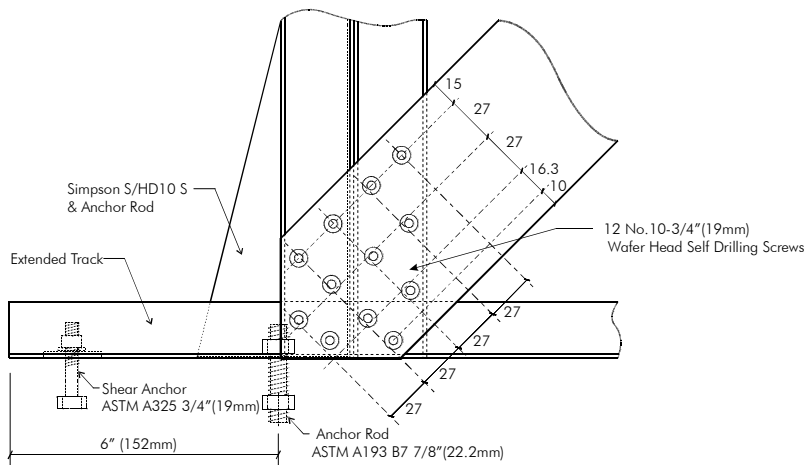
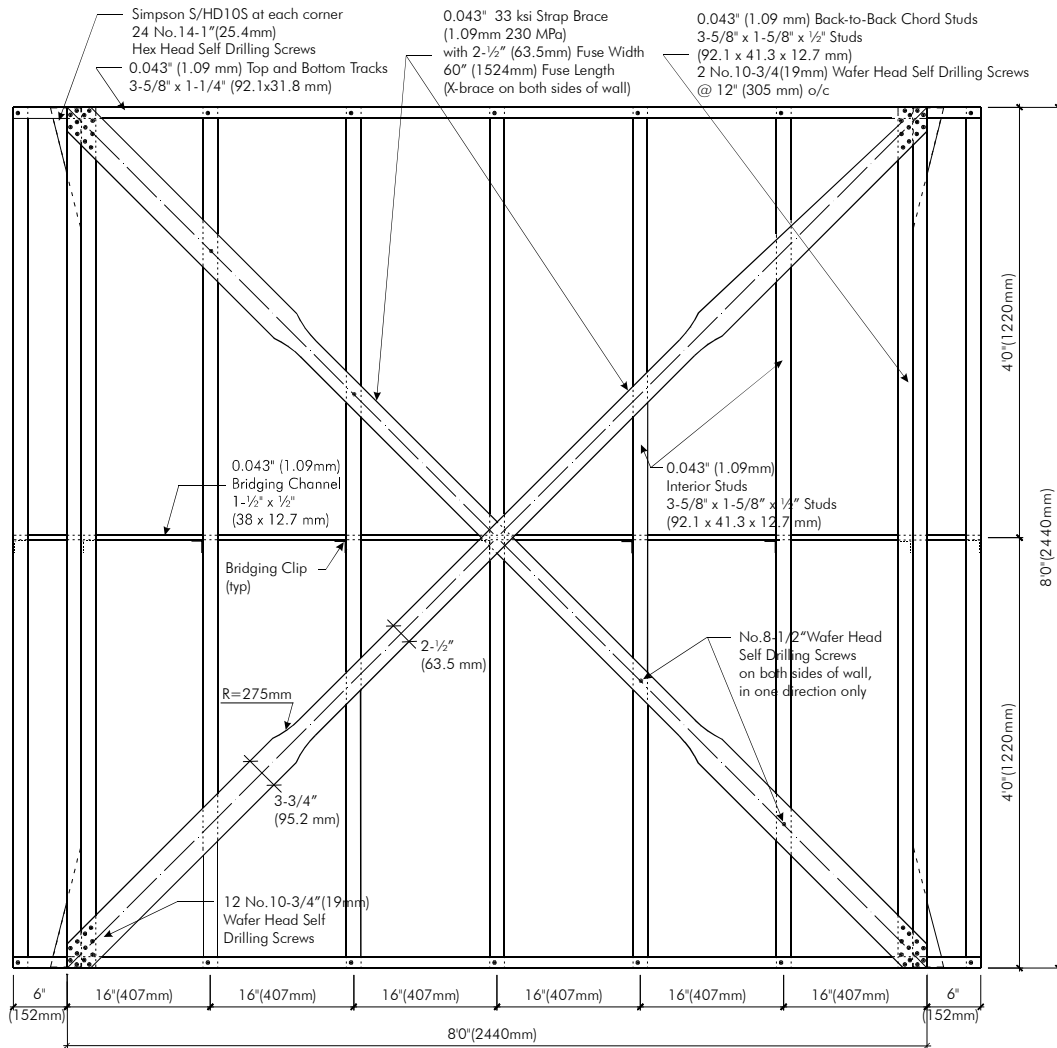

Figure 2.15 Nominal dimensions and the corner detail of specimens 31A-M and 32A-C

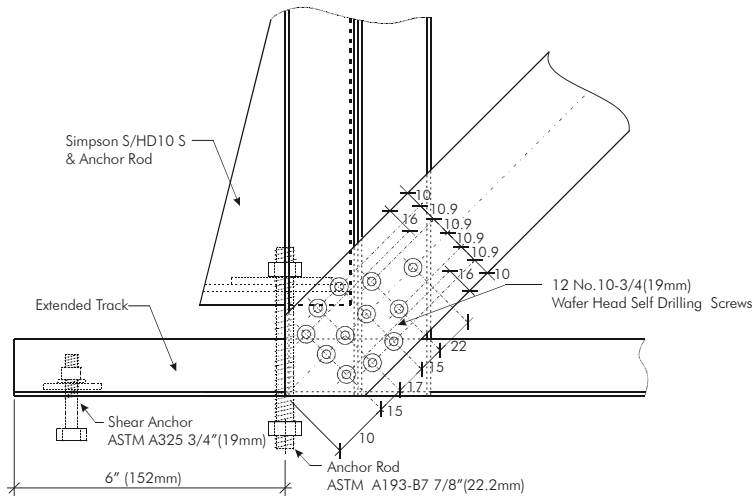
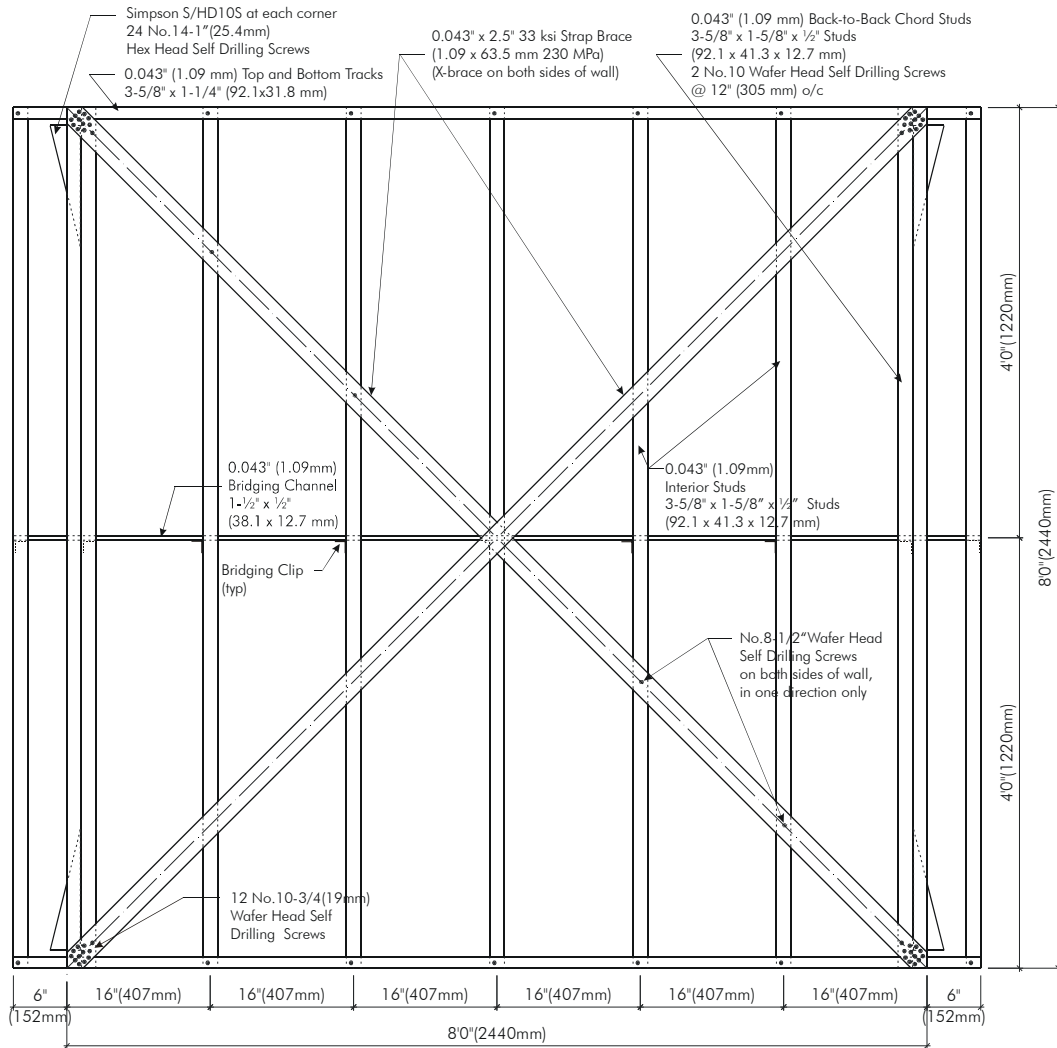

Figure 2.16 Nominal dimensions and the corner detail of specimens 35A-M and 36A-C

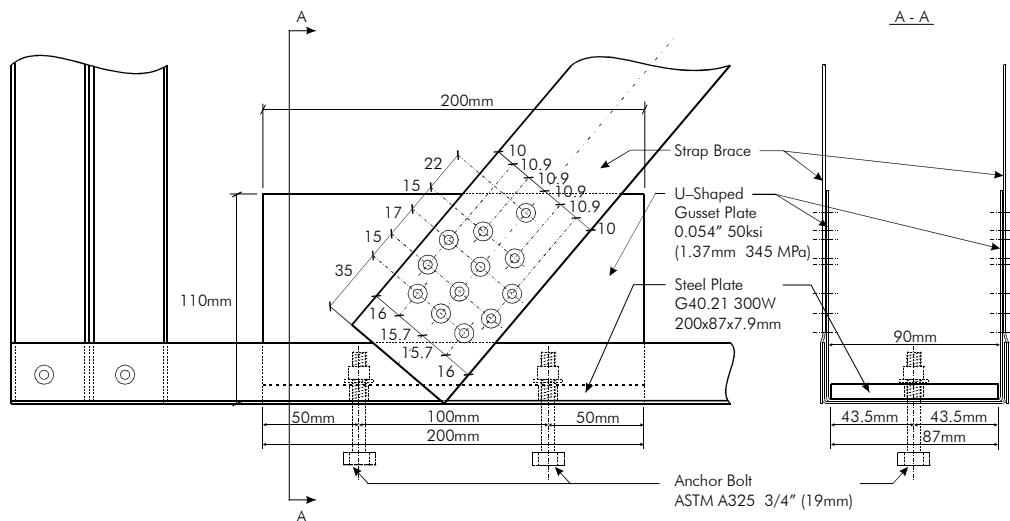
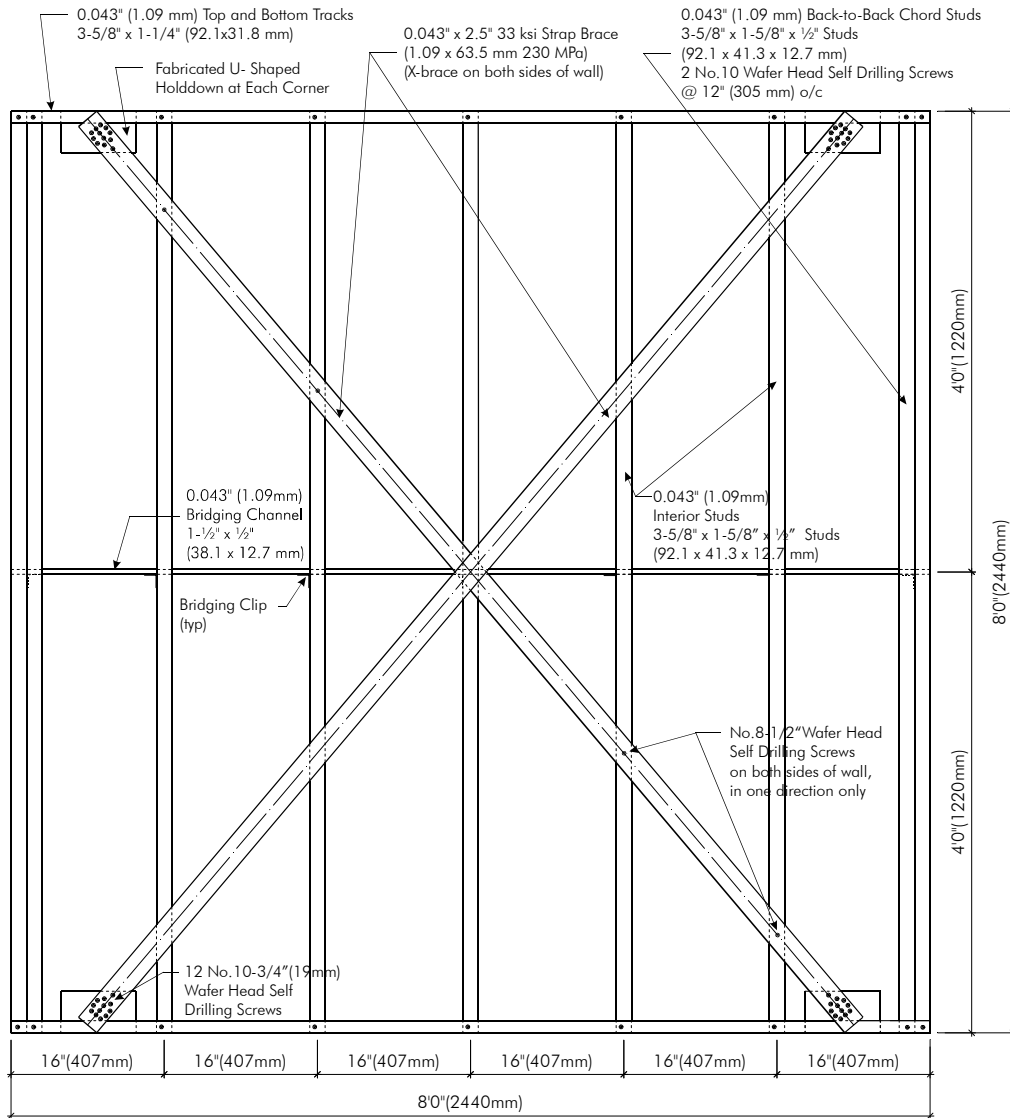

Figure 2.17 Nominal dimensions and the corner detail of specimens 41 A-M and 42 A-C



Figure 2.18 Specimen 25 A-M prior to testing



Figure 2.19 Corner detail of specimens 31 A-M and 35A-M



Figure 2.20 Specimen 42 A-C prior to testing



Figure 2.21 Corner details of specimen 42 A-C

2.3 CONSTRUCTION DETAILS OF MEDIUM TEST WALLS

Representative schematic drawings and corner details of medium walls 9C-M, 27A-M, 28A-C, 39A-M, 40A-C, 47A-M and 48A-C are illustrated in Figures 2.22-2.25. Also, photographs of representative test specimens and details are shown in Figure 2.22 to Figure 2.30.

Specimen 9C-M was constructed with reinforced tracks. A short track segment was placed between the gusset plates and the first interior stud. The reinforcement was placed so that a box section was formed, and the flanges of both sections were connected together with No.10-3/4" (19mm) wafer head self drilling screws at 15 mm o/c. Steel strap braces 0.043"x5", 33ksi (1.09x127mm, 230MPa) placed on both sides of the wall were attached with 19 No.10-3/4" (19mm) wafer head self drilling screws to the gusset plates. A Simpson Strong-Tie S/HD15 was connected to the interior side of chord tracks using 48 No. 10-3/4" (19mm) hex washer head self drilling screws and to the base of the frame and loading beam with a ASTM A193-B7 1" (25.4mm) anchor rod.

Specimens 27A-M and 28A-C had 2743mm (9') long extended tracks and were assembled with steel strap braces 0.054" (1.37mm) thick, 50ksi (340MPa) having a reduced cross section width over a 762mm (30") length. The braces were placed on both sides of the wall and attached with 25 No.10-3/4" (19mm) wafer head self drilling screws to the gusset plates. Simpson Strong-Tie S/HD15S holddowns were connected to the exterior side of the chord studs with 33 No.14-1" (25.4mm) hex washer head self drilling screws and to the base of the frame and loading beam with a 1" (25.4mm) diameter ASTM A193-B7 anchor rod.

Specimens 39A-M and 40A-C were built with reinforced tracks. The first short track section was placed between the chord stud and the first interior frame stud, and the second one between the first and the second frame studs. Flanges of tracks

and reinforcements were connected with No.10-3/4" (19mm) wafer head self drilling screws at 18 mm o/c. Holes were drilled in the flange of the reinforcement track in order for the shear anchor to be tightened. Steel strap braces 0.054"x2.75", 50ksi (1.37x69.8mm, 230MPa), placed on both sides of the wall, were attached with 16 No.10-3/4" (19mm) wafer head self drilling screws to the gusset plates. A Simpson Strong-Tie S/HD15S was connected to the interior side of the chord studs with 33 No.14-1" (25.4mm) hex washer head self drilling screws and to the base of the frame and loading beam with a 1" (25.4mm) diameter ASTM A193-B7 anchor rod.

Specimens 47A-M and 48A-C were fabricated with straps placed only on one side of the wall in order to evaluate the behaviour of non-symmetric braces. They were built in the same way as specimens 39A-M and 40A-C, except that 9' (2743mm) long extended tracks were used instead of reinforced tracks.

Specimens having braces (in one direction) attached to the interior framing studs with No. 8 screws were also tested.

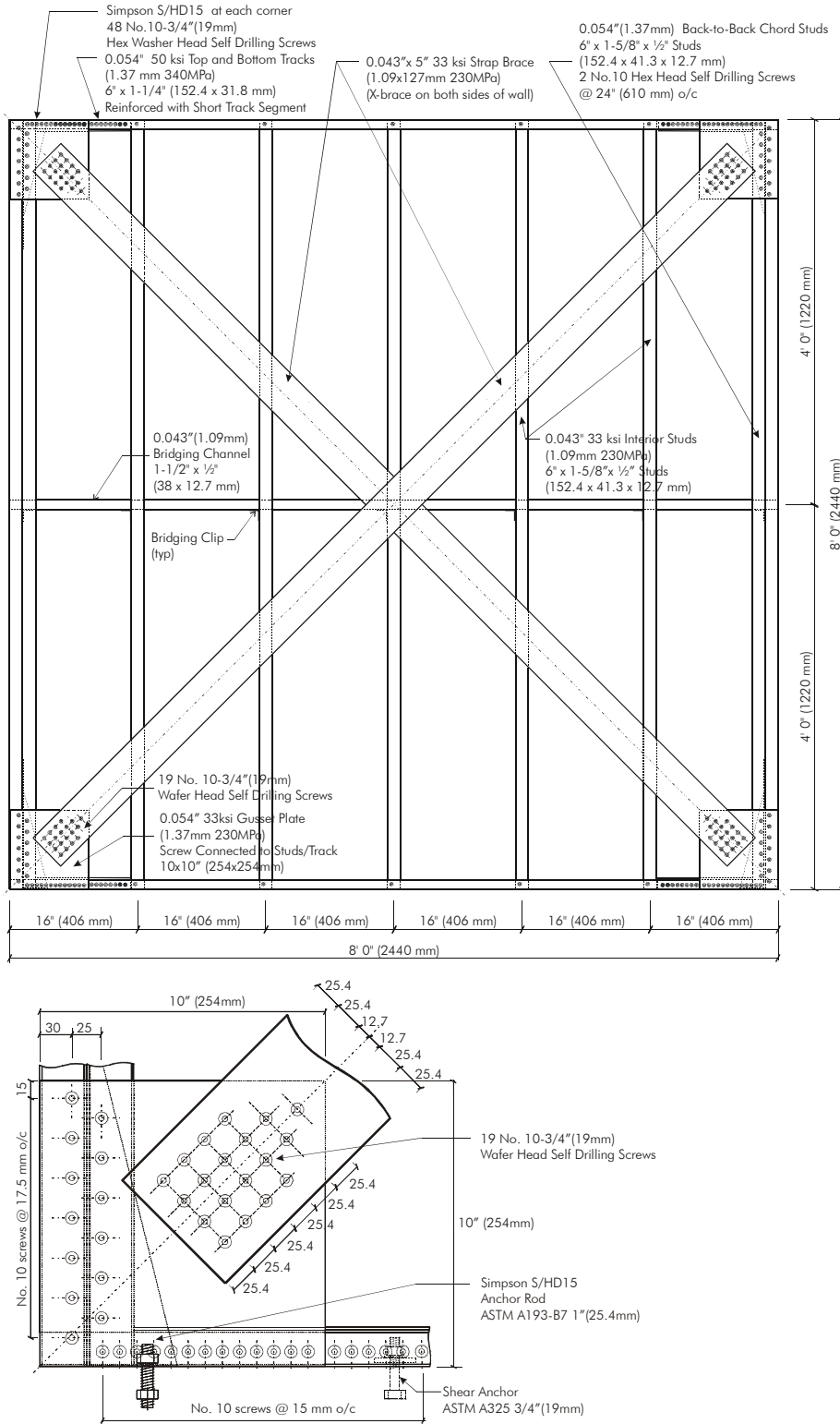

Figure 2.22 Nominal dimensions and the corner detail of specimen 9C-M

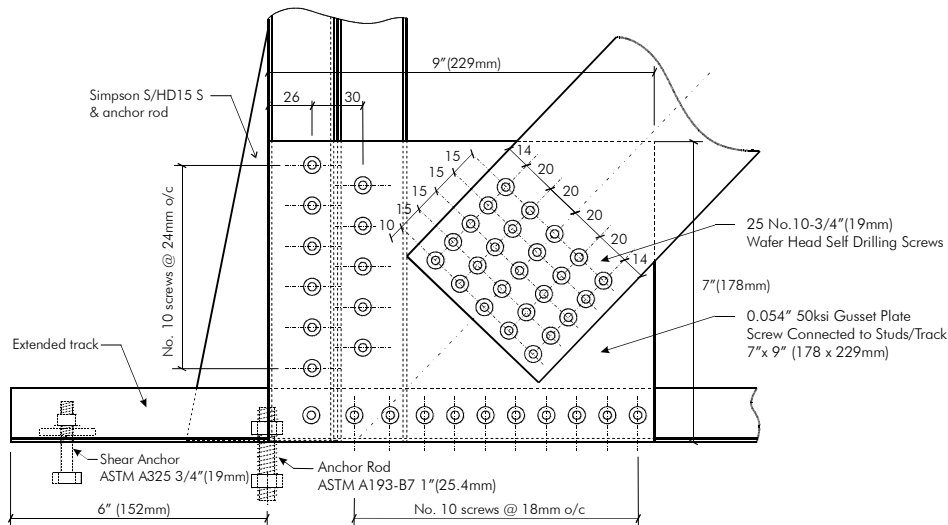
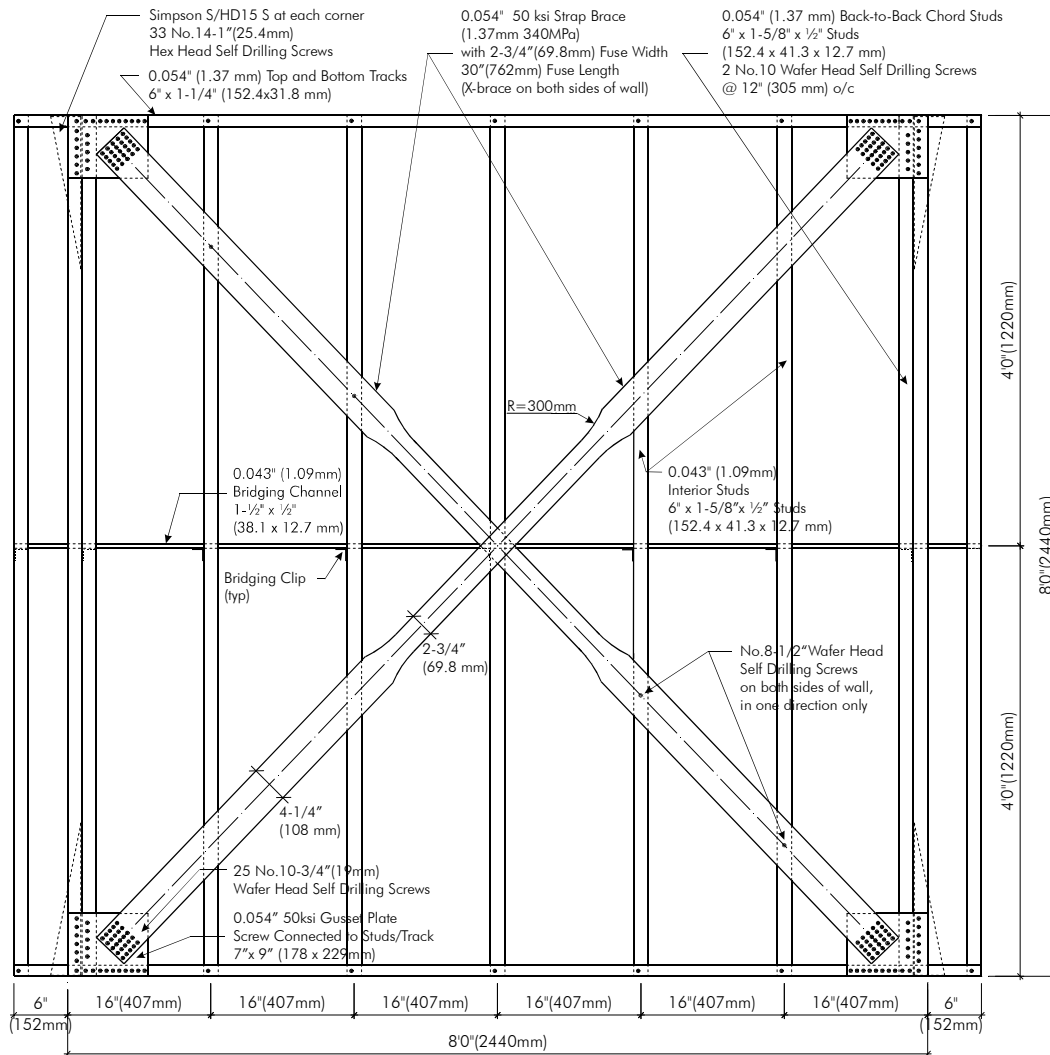

Figure 2.23 Nominal dimensions the corner detail of specimens 27A-M and 28A-C

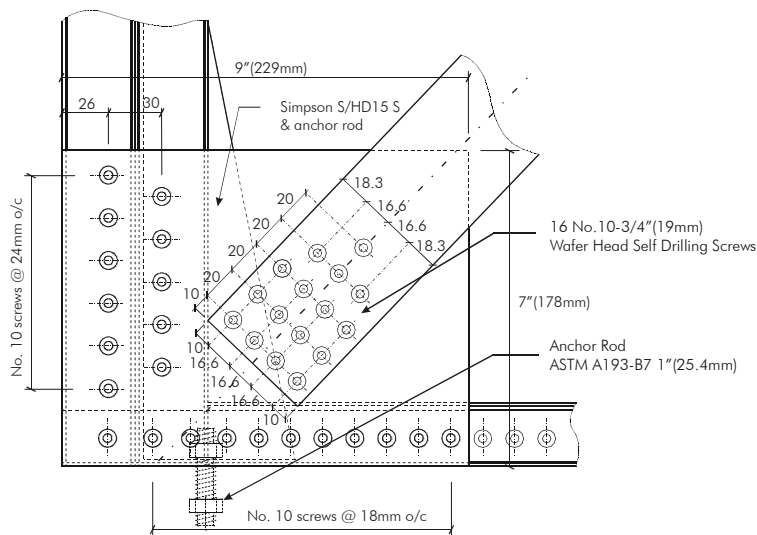
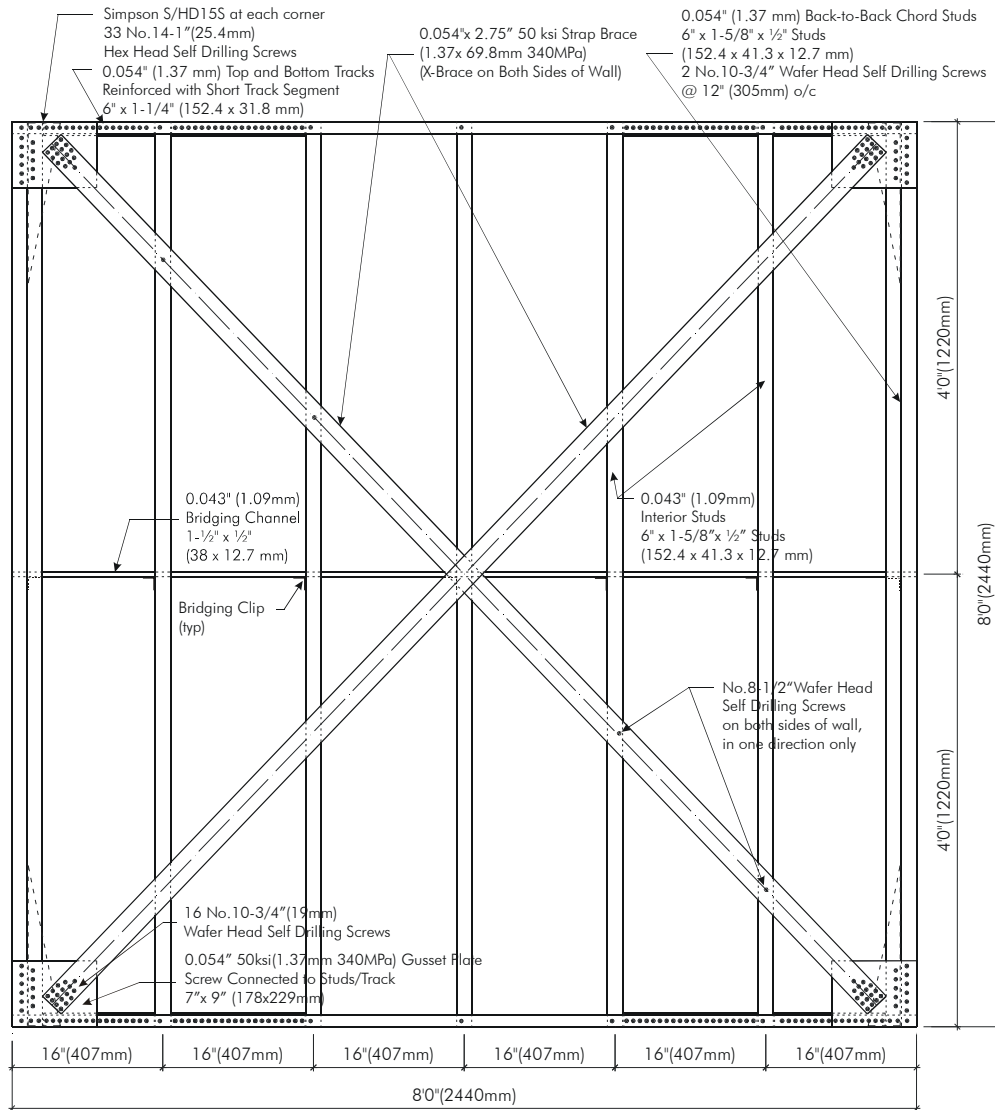

Figure 2.24 Nominal dimensions and the corner detail of specimens 39A-M and 40A-C

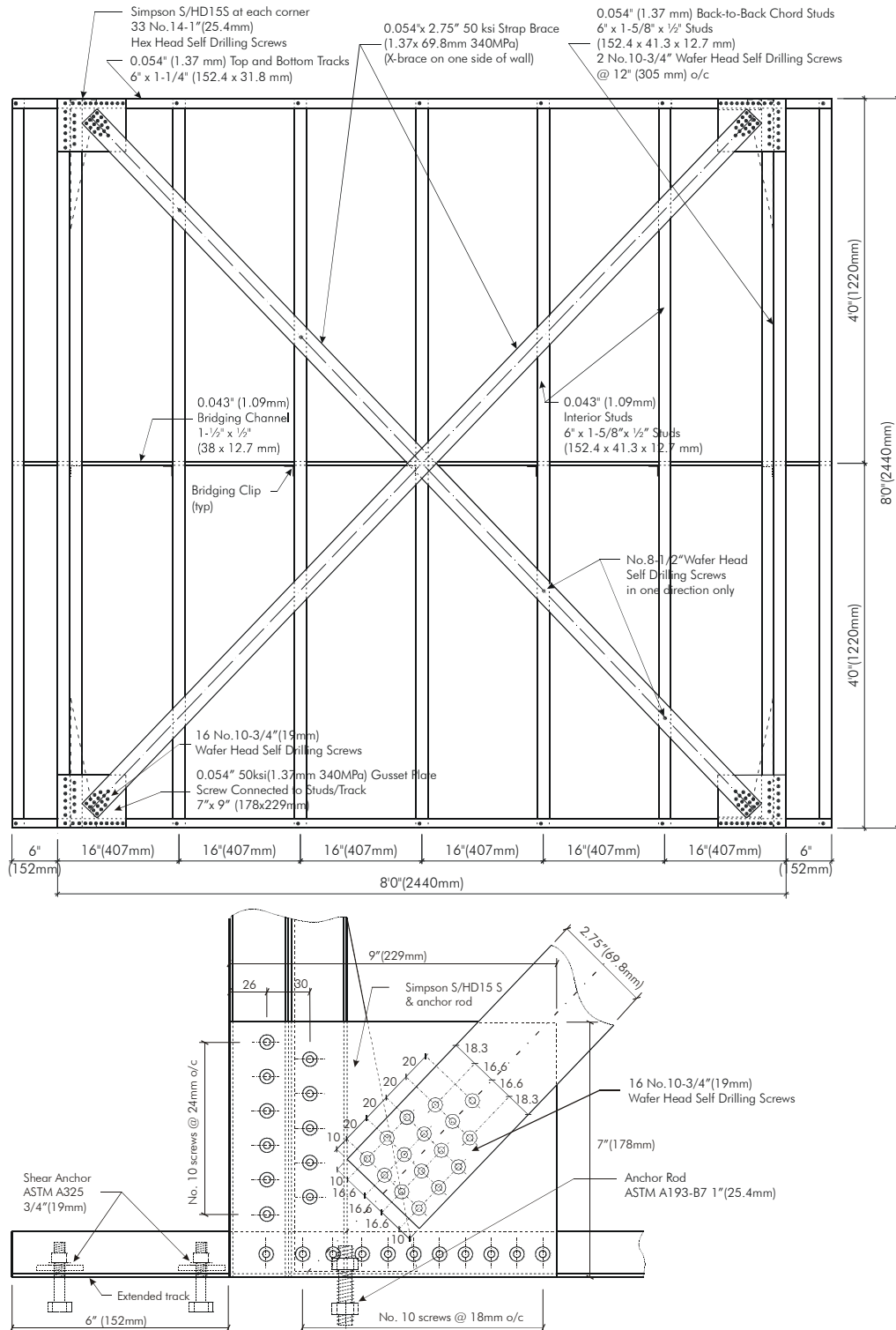

Figure 2.25 Nominal dimensions and the corner detail of specimens 47A-M and 48A-C



Figure 2.26 Strap braced wall specimen 27 A-M in test frame



Figure 2.27 Holddown detail of specimen 27 A-M



Figure 2.28 Strap braced wall specimen 40 A-C in test frame



Figure 2.29 Holddown and track reinforcement detail of specimen 40 A-C



Figure 2.30 Corner details of specimen 48 A-C (left) and 9 C-M (right)

2.4 CONSTRUCTION DETAILS OF HEAVY TEST WALLS

Representative schematic drawings and corner details of heavy walls 29A-M 1, 29A-M 2, 30A-C, 33A-M, 34A-C, 37A-M, 38A-C, 45A-M and 46A-C are illustrated in Figures 2.31-2.35. Also, photographs of representative test specimens and details are shown in Figure 2.31 to Figure 2.41.

Specimens 29A-M1, 29A-M2 and 30A-C were assembled with 2743mm (9') long extended tracks; steel strap braces with reduced cross section width 762mm (30") long were attached with 35 No.10-3/4" (19mm) wafer head self drilling screws to the gusset plates. Specimen 29A-M1 was built with the holddowns placed on the interior of the chord studs, while specimens 29A-M2 and 30A-C were constructed with the holddowns on the exterior of the chord studs. In order to increase the bearing capacity of the tracks a 0.097" (2.46mm) thick, 80x100mm, 50 ksi steel plate was attached by welding at the shear anchor location.

Specimens 33A-M and 34A-C were assembled with 9' (2743mm) long extended tracks; steel strap braces with reduced cross section width 60"(762mm) long and attached with 35 No.10-3/4" (19mm) wafer head self drilling screws to the gusset

plates; holddowns from the exterior side of the chord studs. In order to increase the bearing capacity of the tracks a 0.097” (2.46mm) thick, 80x100mm, 50 ksi steel plate was welded to the extended portion of the track (Figure 2.37).

Specimens 37A-M and 38A-C were constructed with extended tracks. Braces were 101.6mm (4”) wide and connected to gusset plates using 24 No.10-3/4” (19mm) wafer head self drilling screws. The holddowns were raised 51 mm (2”), and placed on the exterior of chord studs. During the monotonic test the bottom track of specimen 37A-M failed in compression, because the horizontal component of the brace force was higher than the bearing capacity of the extended part of the track. That is why in order to increase the bearing capacity of the tracks a 0.097” (2.46mm) thick, 80x100mm, 50 ksi steel plate was welded to the tracks of specimen 38A-C.

Specimens 45A-M and 46A-C were built with reinforced tracks. The first short reinforcement section was placed between the chord stud and the first interior frame stud, and the second one between the first and the second frame studs. Flanges of tracks and reinforcements were connected with No.10-3/4” (19mm) wafer head self drilling screws at 15 mm o/c distance. Holes were drilled in the flange of the reinforcement track in order to tighten the shear anchors. Steel strap braces 4” (101.6mm) wide were attached with 25 No.10-3/4” (19mm) wafer head self drilling screws to the gusset plates. Screws were assembled in a square pattern. A Simpson Strong-Tie S/HD15S was placed on the interior of chord studs and regular 2440 mm (8”) long tracks were used.

Specimens having braces attached (in one direction) to the interior framing studs with No. 8 screws were also tested.

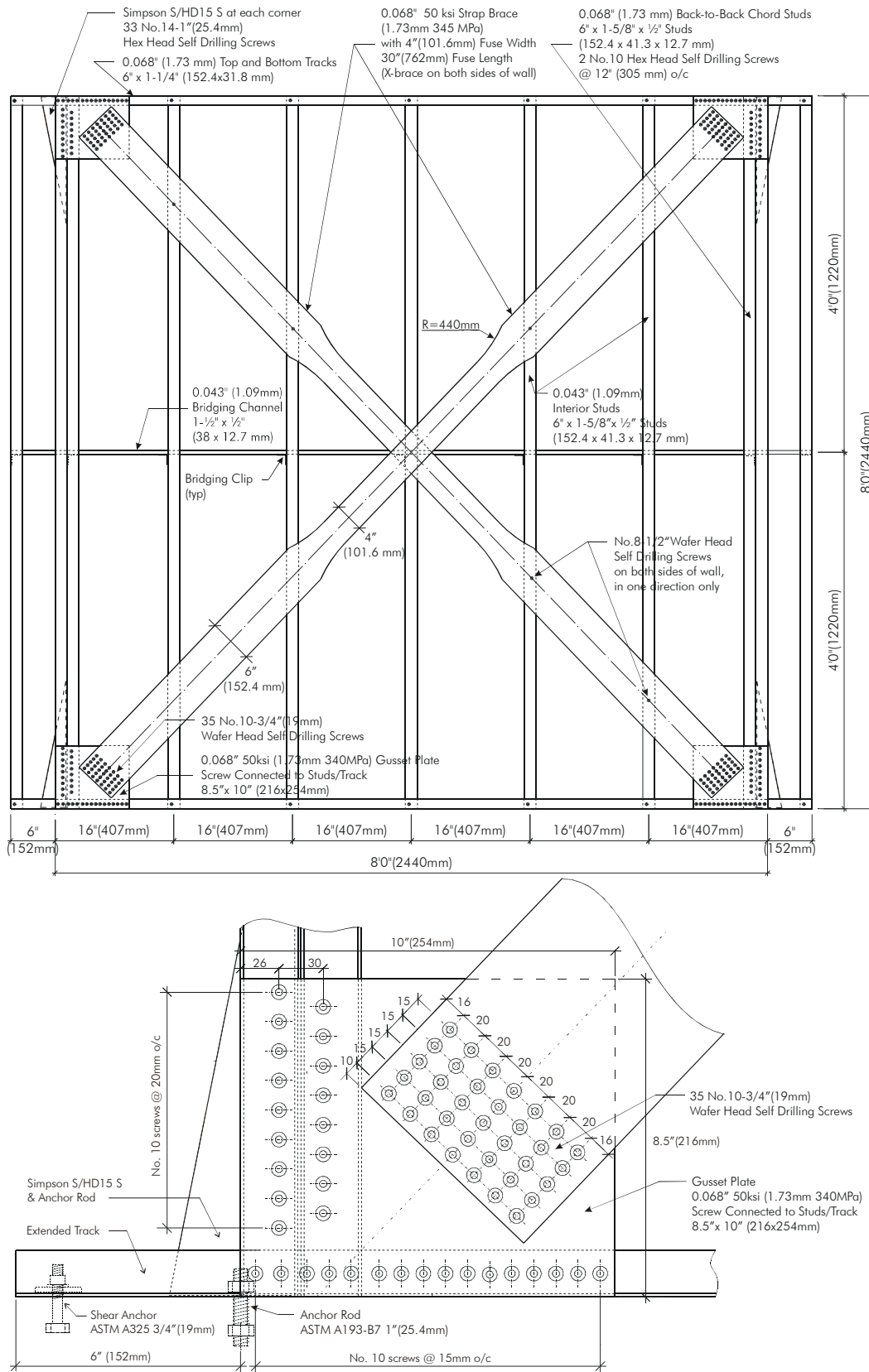

Figure 2.32 Nominal dimensions and corner detail of specimens 29A-M 2 and 30A-C

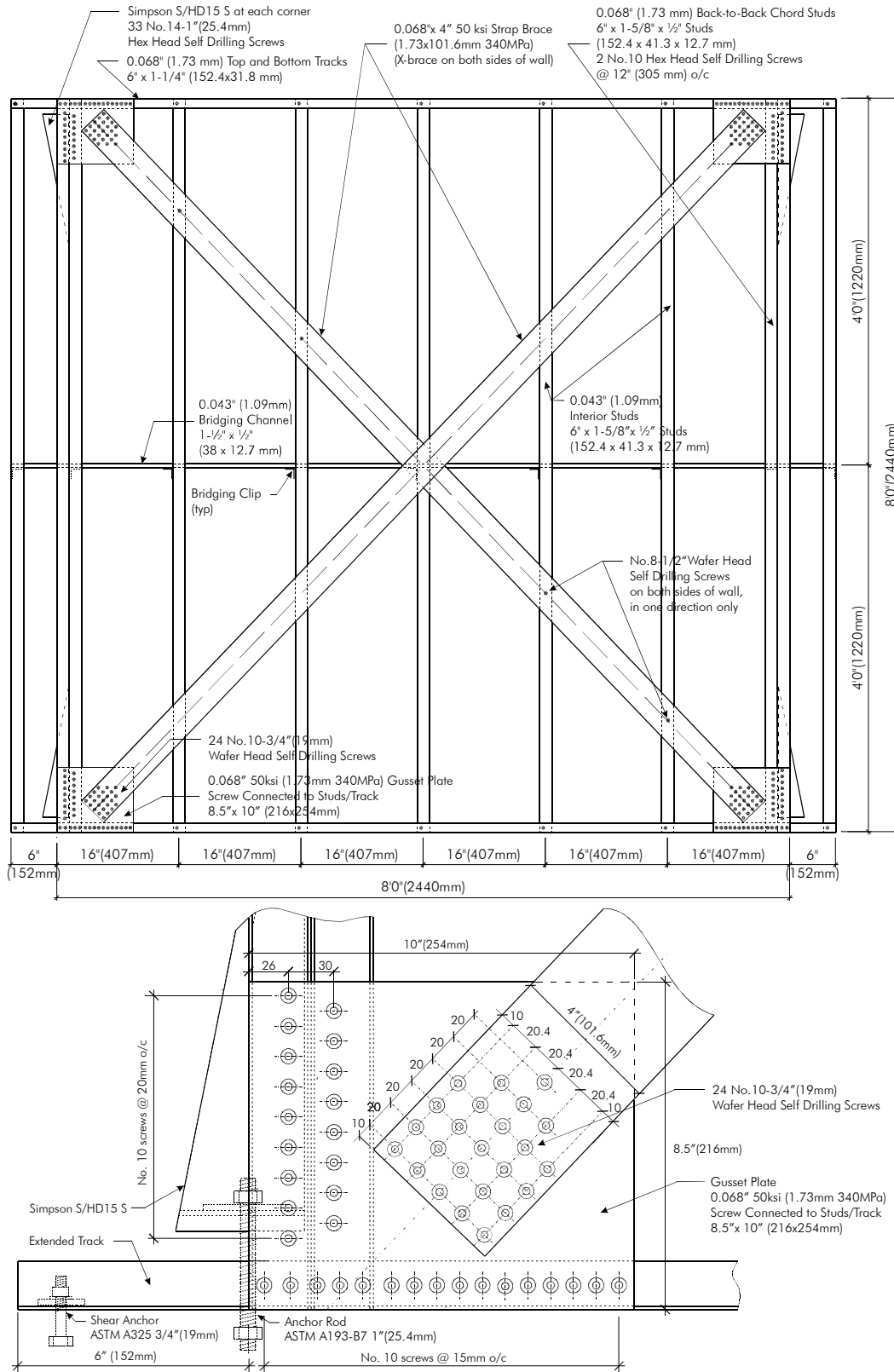

Figure 2.34 Nominal dimensions corner detail of specimens 37A-M and 38A-C

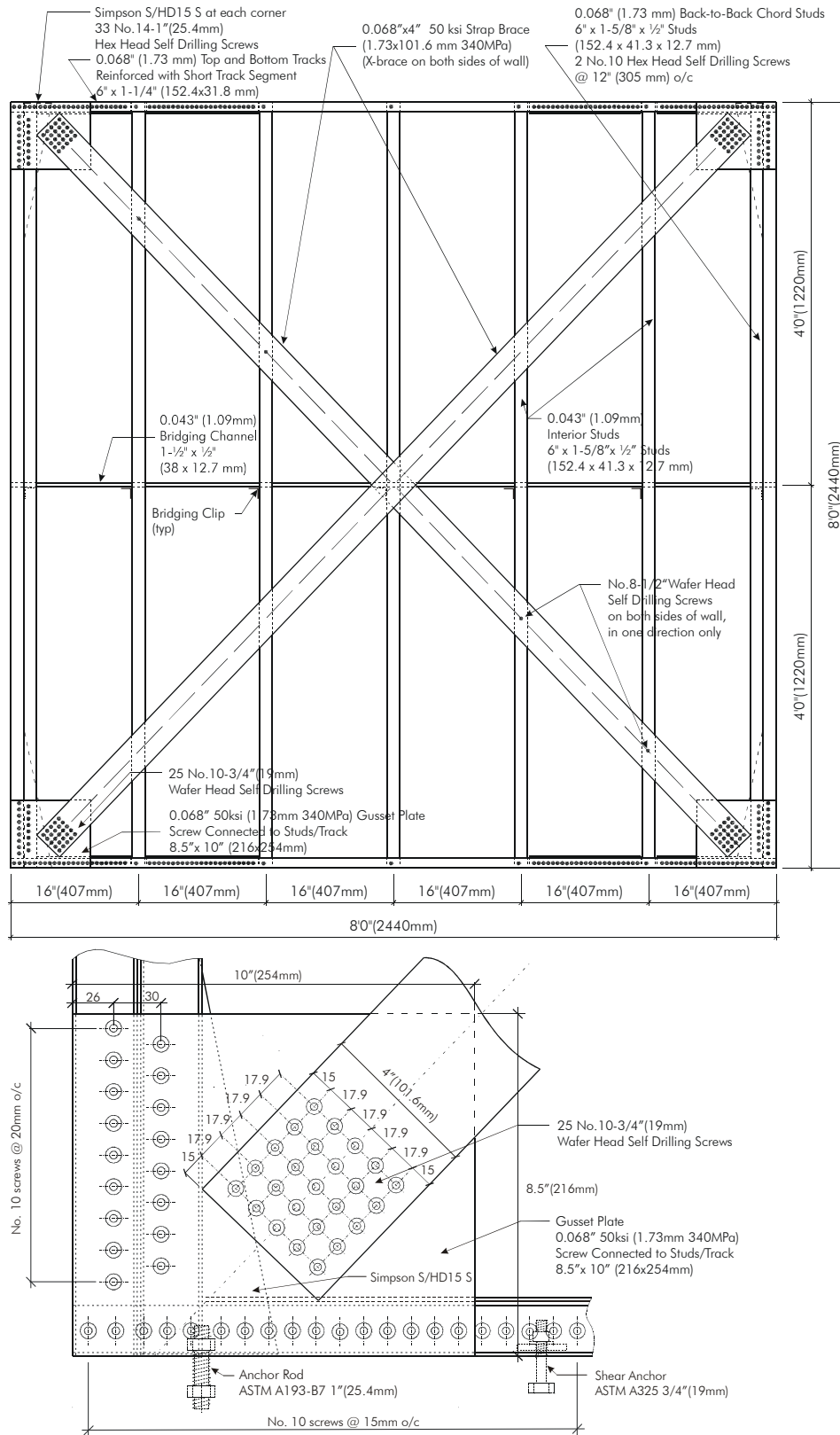

Figure 2.35 Nominal dimensions and corner detail of specimens 45A-M and 46A-C



Figure 2.36 Strap braced wall specimen 30 A-C in test frame



Figure 2.37 Corner detail of specimen 30 A-C

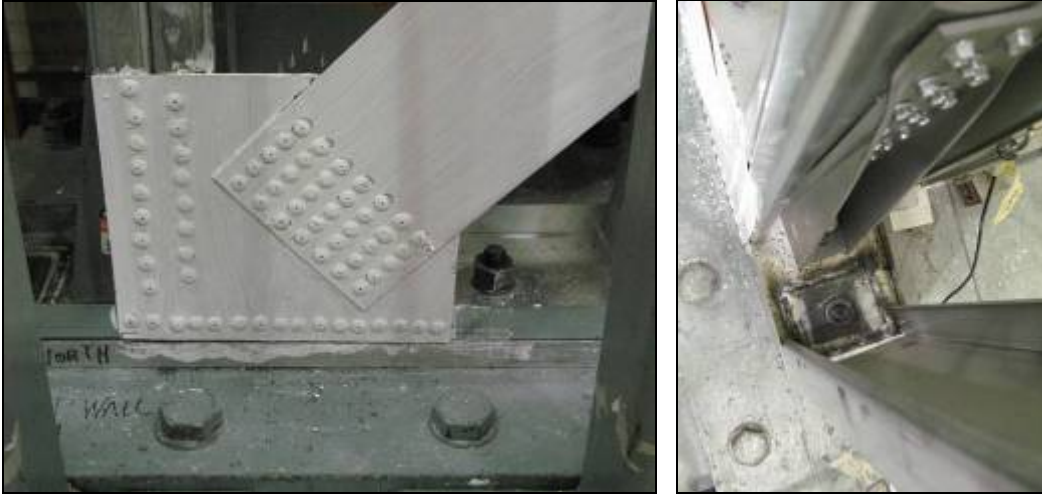

Figure 2.38 Corner detail of specimen 34 A-C



Figure 2.39 Strap braced wall specimen 37 A-M in test frame



Figure 2.40 Corner detail of specimens 37 A-M (left) and 38A-C (right)



Figure 2.41 Corner detail of specimen 46 A-C

2.5 TEST ASSEMBLY AND INSTRUMENTATION

All walls were built at the Jamieson Structures Laboratory at McGill University. Prior to wall assembly the chord studs were first connected with screws back-to-back; holddowns were then attached. The tracks were drilled so that the holes matched the existing shear and anchor rod holes of the loading beam and base plate of the testing frame (Figure 2.42); Bridging clips were attached to all studs and the positions of

screws was marked on braces and gusset plates. The studs and track were then assembled and the wall was measured to ensure that it was square. Gusset plates were installed for the medium and heavy walls. One end of the straps was then screw connected to the wall. The other end was manually pretensioned to avoid slack in the brace and then screw connected. Finally the bridging member was placed through the web knockout holes and connected to the bridging clips.

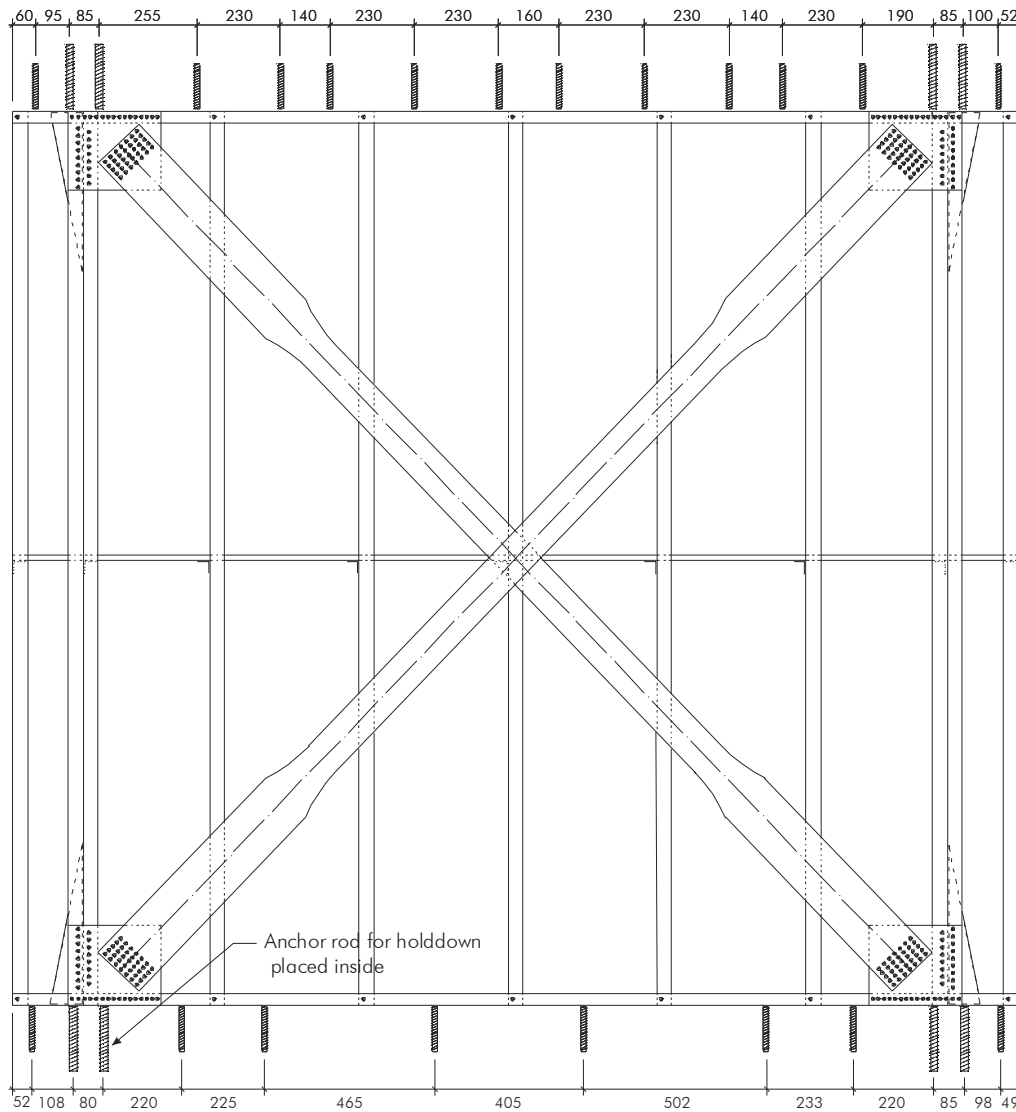

Figure 2.42 Typical anchorage for walls specimens, mm

Once the wall was constructed strain gauges were installed on the back straps. Three and five strain gauges were used for the monotonic test walls with regular and

reduced cross section braces, respectively. Six strain gauges (three per brace) were used for the cyclic test specimens. The position of strain gauges is given in Appendix C.

Load cells were installed on the two bottom holddown anchor rods to measure the uplift force during the test. These load cells were also used to balance the force in the holddown threaded rods prior to testing (approx. 9 kN each). The two top anchor rods were secured using the turn-of-the-nut method. All shear anchors were tightened using an electric impact wrench for 10s from hand-tight position.

Four linear variable differential transformers (LVDTs) were installed to measure the uplift and in-plane slip at each bottom corner of the wall (Figure 2.43). One string potentiometer was used to measure the in-plane lateral displacement at the top corner of the wall. A load cell was used to measure the shear force applied on the loading beam. Also, an accelerometer was attached to the loading beam for the cyclic tests.

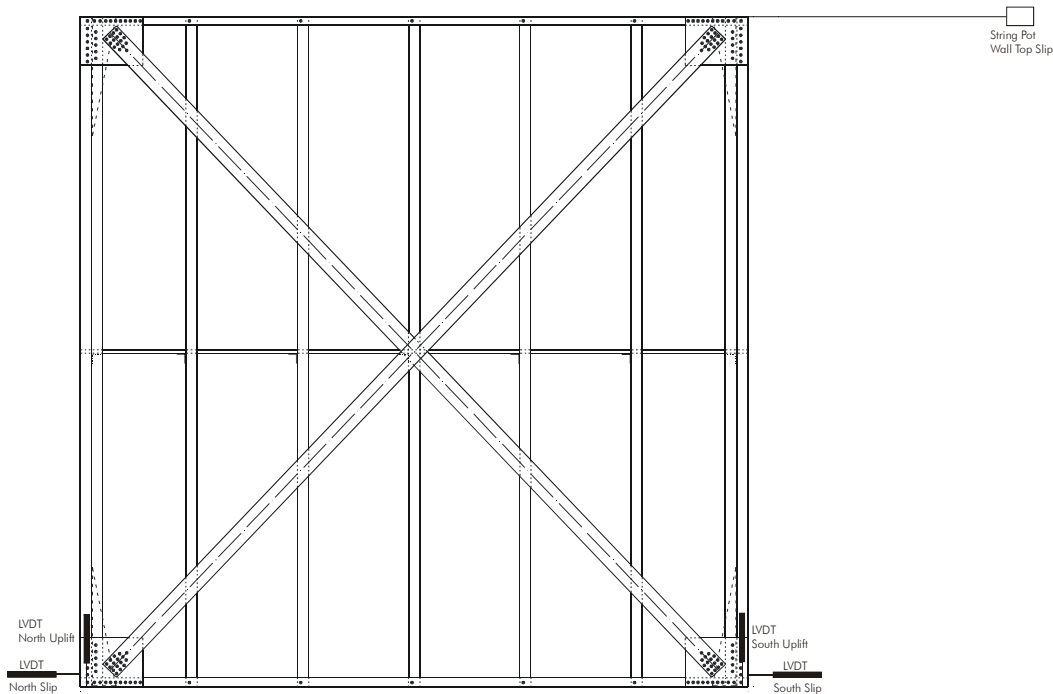

Figure 2.43 Positioning of the LVDTs and the string potentiometer

2.6 MONOTONIC LOAD PROTOCOL

Eighteen of the wall specimens were tested under monotonic loading at a constant rate of displacement 2.5mm/min. This protocol was the same as that used by Al-Kharat and Rogers (2007, 2008). Once the wall had been installed in the test apparatus, the applied force to the wall was reduced to zero by making slight adjustments to the position of the actuator. The specimens were tested to failure or until the full travel of the actuator (approx. 220mm or 9% drift) was reached. An example of a typical resistance versus displacement graph is presented in Figure 2.44.

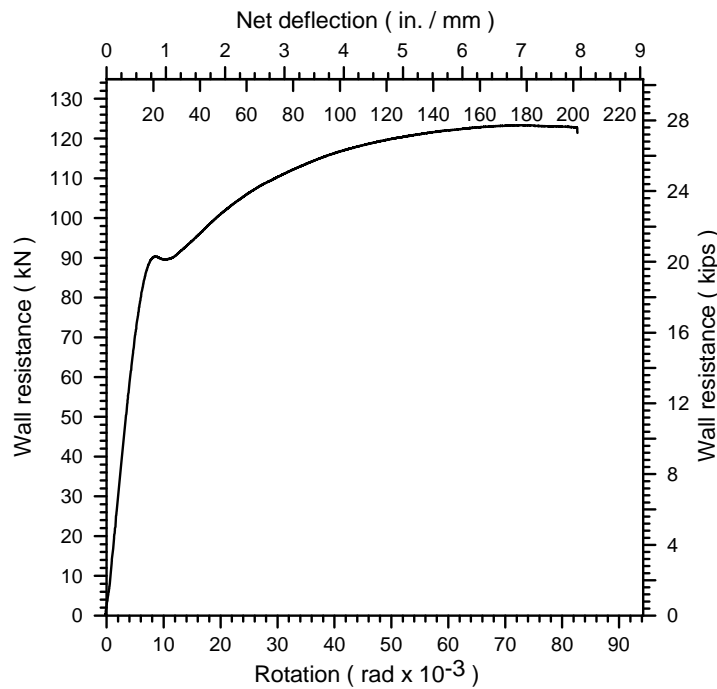

Figure 2.44 Typical shear resistance vs. deflection curve for a monotonic test (Specimen 29A-M1)

2.7 REVERSED CYCLIC LOAD PROTOCOL

Twelve of the specimens were tested under the CUREE (Consortium of Universities for Research in Earthquake Engineering) reversed cyclic load protocol

for ordinary ground motions (*Krawinkler et al., 2000*). This protocol was chosen because it is specified in ASTM E2126 (2005) for wall assemblies with wood or metal framing and solid sheathing, bracing, or structural insulated panels. Also, this protocol was used for the cyclic tests in the two previous phases of this project. Furthermore, the same protocol was implemented in cyclic tests of cold-formed steel frame shear walls with wood sheathing, which are an alternative to strap braced walls.

The CUREE protocol was developed to evaluate the resistance of elements subjected to ordinary (not near-fault) earthquakes with the probability of exceedance of 10% in 50 years. The loading history of the CUREE protocol consists of initiation, primary and trailing cycles, the amplitudes of which are defined as multiples of the reference deformation. The latter was defined as $\Delta = 2.667 \Delta_{Sy}$ (*Al-Kharat & Rogers, 2005, 2007*), where Δ_{Sy} is the wall top displacement, obtained from a nominally identical monotonically tested wall specimen (Figure 2.47). A typical reversed cyclic displacement protocol is shown in Figure 2.45. All cyclic protocols that were used are given in Appendix B.

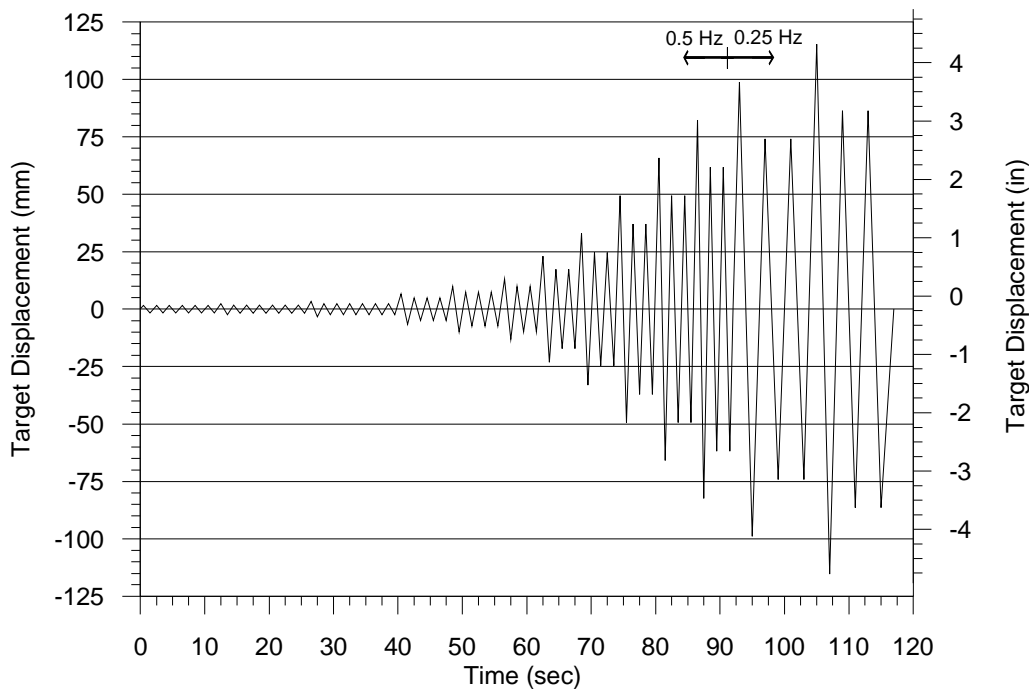

Figure 2.45 Typical reversed cyclic test protocol (Specimen 28A-C)

The frequency of the protocol was 0.5 Hz, and only towards the end of the loading protocol when the displacement of the actuator was more than 100mm was the frequency reduced to 0.25 Hz. These two frequencies were chosen because of the limitations of the hydraulic pump and oil supply at the actuator. A typical wall resistance versus deflection curve for a reversed cyclic test is shown in Figure 2.46. Note, the reversed cyclic tests were run with a maximum displacement of $\pm 4.5\%$ storey drift, much less than the 9% that could be reached during the monotonic tests. These drift amounts were set based on the limited stroke of the actuator.

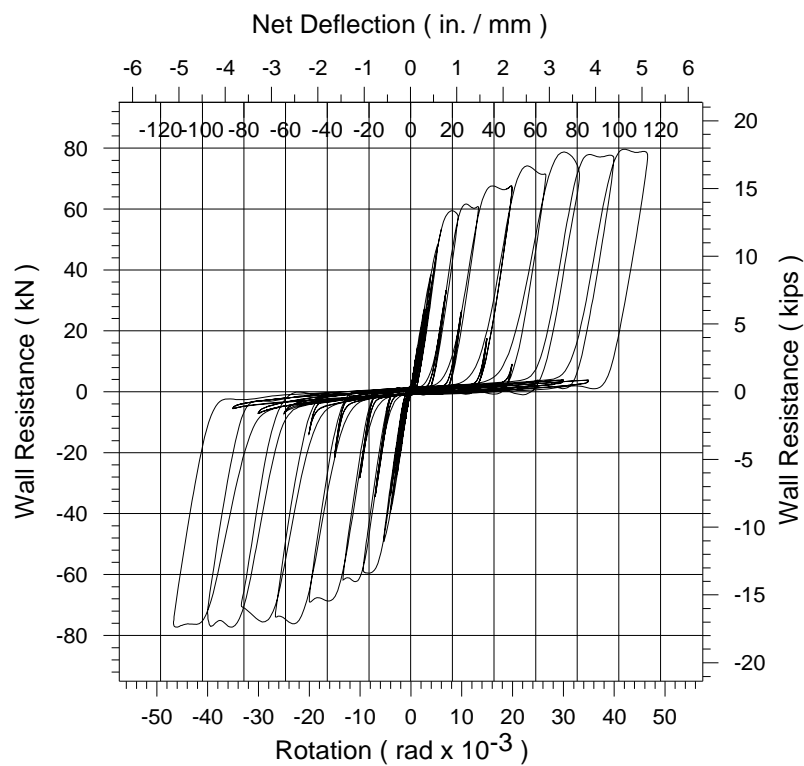

Figure 2.46 Shear resistance vs. deflection response curve

2.8 MEASURED AND PREDICTED PROPERTIES

A typical graph from a monotonic and cyclic test illustrating all measured and predicted parameters is shown in Figure 2.47.

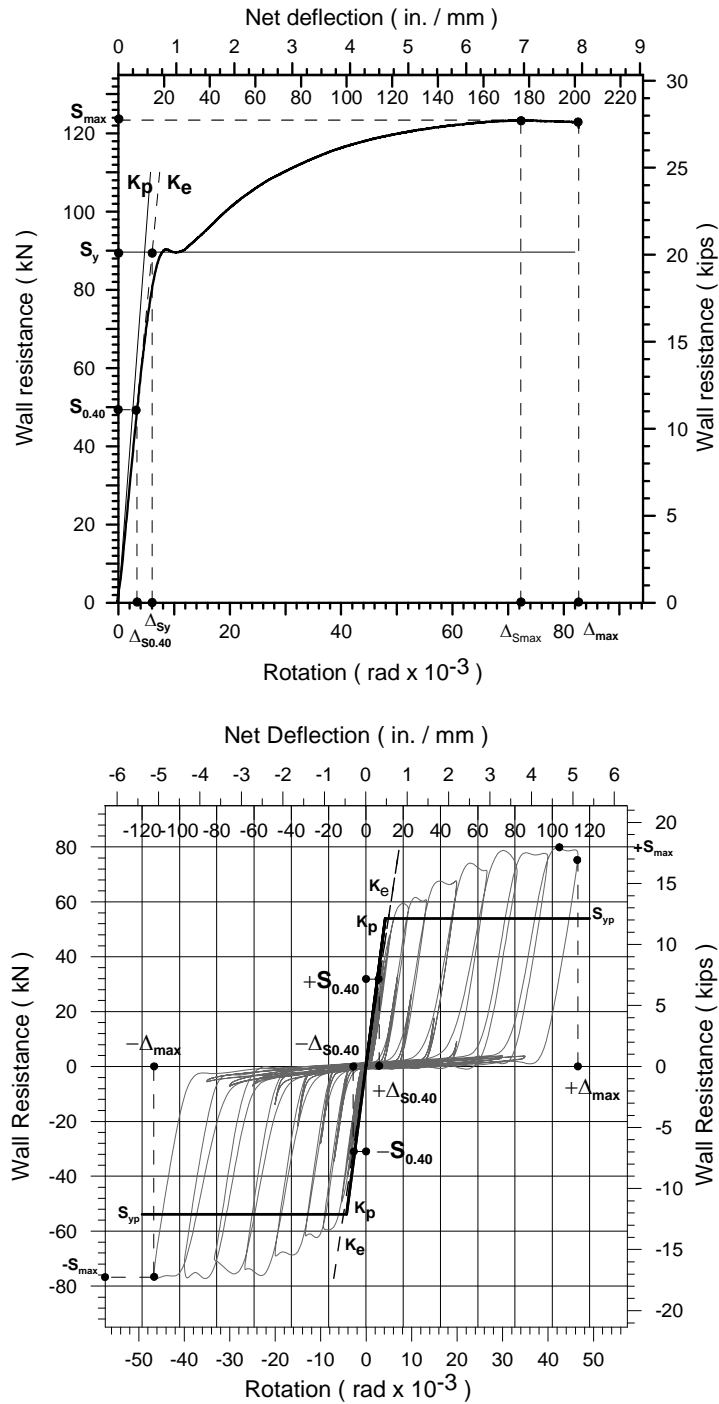

Figure 2.47 Definition of measured wall parameters for monotonic and cyclic tests

2.8.1 Stiffness properties

Following the recommendation of ASTM E2126 (2005), the measured elastic shear stiffness K_e of a wall specimen is defined as:

$$K_e = \frac{S_{0.40}}{\Delta s_{0.40}} \quad (2.10)$$

where $S_{0.40} = 0.4S_{max}$; S_{max} is the maximum resistance reached by each specimen during testing regardless of the failure mode; $\Delta s_{0.40}$ is the measured displacement at $S_{0.40}$ (Figure 2.47).

It was considered that at 40% level of ultimate resistance the specimen is in the elastic range of behaviour. Also, Al-Kharat and Rogers (2007, 2008) used the same approach to calculate the measured elastic stiffness of a strap braced wall.

During the preceding two phases of the project the predicted elastic lateral in-plane stiffness of the strap braced wall was based only on the axial stiffness of the braces; it was established that this is higher than what was measured during testing (Al-Kharat and Rogers 2005, 2007).

Following the recommendations of Al-Kharat and Rogers (2008) the connection, holddown and anchor rod stiffness were also included in the calculations. The equivalent spring model used to determine the predicted elastic stiffness of a wall specimen is shown in Figure 2.48.

Each brace was assumed to be comprised of three springs connected in series that represent the stiffness of the brace K_b , the stiffness of the fuse K_f , and the stiffness of the screw connections K_c . The stiffness of the brace was computed as;

$$K_{b'} = \frac{EA_b}{2l_b} \quad (2.11)$$

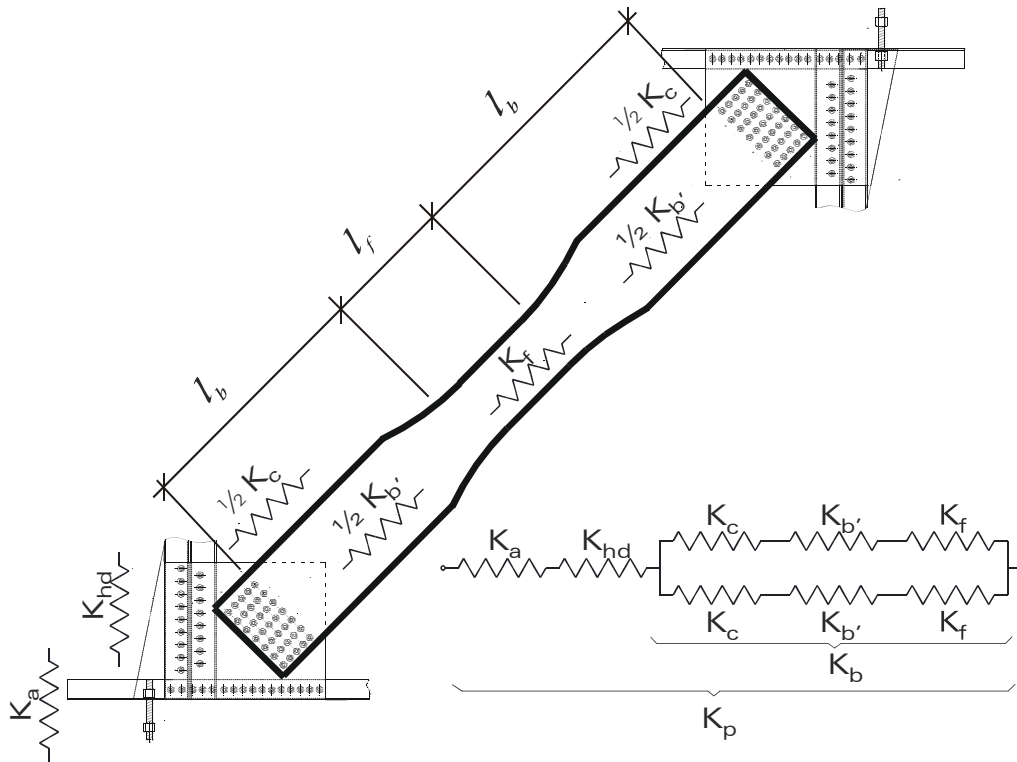

Figure 2.48 Model for the predicted stiffness

Where the modulus of elasticity $E = 203\,000$ MPa; A_b is the cross-section area of the strap brace; l_b is the length of the strap according to Figure 2.48. Note, for a regular brace l_b is the length of the brace between screw connections.

The stiffness of the fuse was computed as

$$K_f = \frac{EA_f}{l_f} \quad (2.12)$$

where A_f is the cross-section area of the fuse; l_f is the length of a fuse according to Figure 2.48.

To determine K_c a screw connection tension test presented in Figure 2.49 was carried out. The screw pattern and materials matched those used in the wall specimens. First the measured initial stiffness K_e of the tested connection specimen was determined in accordance with Equation 2.10, and after that K_c was obtained from Equation 2.13.

$$K_c = \frac{K_s K_e}{K_s - K_e} \quad (2.13)$$

Where $K_s = EA_b/l_s$; A_b is the measured cross-section area of the strap; l_s is the length of a strap between two connection according to Figure 2.49.

Equation 2.13 gives the stiffness of the two screw connections when the stiffness of the tested specimen is modeled as an equivalent stiffness of two springs connected in series.

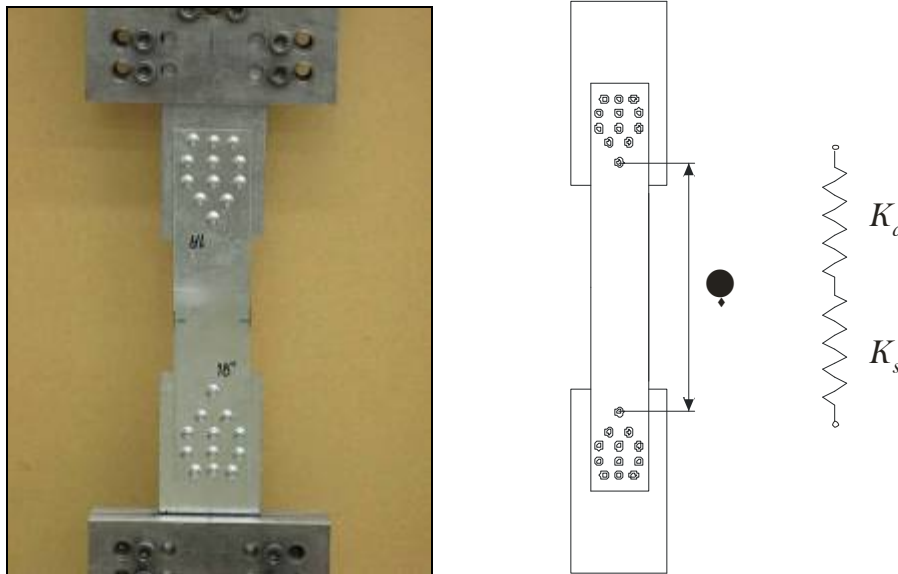

Figure 2.49 Connection test

Once the total stiffness of the connections K_c was determined it was assumed that fasteners will act as a set of springs connected in parallel, so the stiffness of a single fastener K_{ss} could be given as:

$$K_{ss} = \frac{2K_c}{n} \quad (2.14)$$

where K_c is the stiffness of the two screw connections; n is the number of screws in one connection only. For the connection shown in Figure 2.49, $n = 12$.

Following this procedure for the connection specimens shown in Figure 2.49, the stiffness of a single fastener $K_{ss} = 1.775$ kN/mm was computed. This value was used in the calculation of the stiffness for all wall specimens. It should be noted that this approach is approximate, and more screw connection tests should be carried out for different numbers of screws and different thickness and grade of connected cold-formed gusset plates and strap braces. The stiffness of the connection K_c per each wall was determined as:

$$K_c = \frac{nK_{ss}}{2} \quad (2.15)$$

Where n is the number of screws in one connection only; $K_{ss} = 1.775$ kN/mm as determined from the test.

The stiffness of the brace K_b was obtained from

$$\frac{1}{K_b} = \frac{1}{K_c} + \frac{1}{K_b'} + \frac{1}{K_f} \quad (2.16)$$

where $1/K_f = 0$ for regular braces

The stiffness of the anchor rod was computed as:

$$K_a = \frac{EA_{an}}{l_{an}} \quad (2.17)$$

where A_{an} is the net cross-section area of the anchor rod, and l_{an} is the length of the anchor rod.

The stiffness of the holddown was based on data obtained from the Simpson Strong-Tie catalogue (2007). The stiffness was determined as:

$$K_{hd} = \frac{T_{hd}}{\delta_{hd}} \quad (2.18)$$

Where T_{hd} is the highest allowable design load and δ_{hd} is the holddown deflection at the highest allowable design load.

The predicted stiffness of the test specimen K_p was computed as:

$$\frac{1}{K_p} = \frac{1}{K_a} + \frac{1}{K_{hd}} + \frac{1}{mK_b \cos^2 \alpha} \quad (2.19)$$

where m is the number of braces, and α is the angle of straps with respect to horizontal. All wall specimens were constructed with braces on both sides and $m = 2$, except specimens 47A-M and 48A-C, which were built with braces on one side only and $m = 1$. Equation (2.19) is valid only for square walls and it is approximate because the wall is assumed to be rigid and rotating around one of the bottom corners.

The predicted stiffness of a wall specimen K_n was similar to K_p except that it was based on the nominal dimension of the strap braces. The values of K_e , K_p and K_n are presented in Appendix A.

2.8.2 Lateral resistance properties

The measured yield strength S_y for all monotonic tests is defined as the yield plateau (Figure 2.47). The maximum lateral resistance reached in a monotonic or cyclic test is S_{max} ; it is higher than S_y because it includes strain hardening effects

and strain rate effects (cyclic tests). It was not possible to identify a yield plateau for the cyclic tests due to the effect of the increased strain rate.

The actual predicted resistance of a wall S_{yp} based on cross-section yielding of the strap braces was computed as

$$S_{yp} = 2A_b F_y \cos \alpha \quad (2.20)$$

where A_b is the measured cross-section area of one strap (or cross-section area of the fuse in the case of fuse braces); F_y is the yield stress as obtained from the coupon tests (Table 2.7); and α is angle of straps with respect to horizontal. The nominal predicted lateral yield resistance S_{yn} of each wall was determined using the nominal area of the brace (or the nominal area of the fuse in the case of fuse braces) as well as the minimum specified yield strength. Tables in Appendix A list the predicted S_{yp} and S_{yn} values. The actual strap dimensions were measured before the beginning of each test and actual yield stress was determined from coupon tests.

In order to examine the value of the R_y factor listed in AISI S213 another nominal prediction S_{yc} (Equation 2.21) representing the capacity design yield load was calculated and compared with the measured load at which the braces started to yield S_y .

$$S_{yc} = 2A_b R_y F_y \cos \alpha \quad (2.21)$$

All shear resistance vs. deflection graphs, and tests results from monotonic and cyclic tests are also presented in Appendix A.

2.8.3 Seismic design properties

The ductility factor μ was determined according to ASTM E2126 (2005) as:

$$\mu = \frac{\Delta_{max}}{\Delta_{S_y}} \quad (2.22)$$

where Δ_{max} is the displacement corresponding to the failure limit state or the full travel of the actuator; $\Delta_{S_y} = S_y / K_e$ is the ideal elastic yield displacement; S_y is the load at which the braces started to yield. Note, for the cyclic tests $\Delta_{S_y} = S_{yp} / K_e$ and $S_{yp} = 2A_b F_y \cos \alpha$. The predicted load at which the braces started to yield S_{yp} was used because it was not possible to determine the yield load from the cyclic test results. The maximum displacement that was reached during a test Δ_{max} , the measured ductility μ and the maximum drift level are also listed in the tables given in Appendix A.

The “test based” seismic force modification factors R_d and R_o were obtained following a similar procedure to that described by Mitchell et al. (2003). The ductility related factor R_d was computed as:

$$R_d = \sqrt{2\mu - 1} \quad (2.23)$$

where μ is the measured ductility. The overstrength related seismic force related modification factor R_o was estimated as:

$$R_o = R_\phi R_{yield} R_{sh} \quad (2.24)$$

where $R_\phi = 1/\phi$ accounts for the difference between nominal and factored resistance, $\phi = 0.9$ is the material resistance factor as defined in the CSA S136 Specification (2007); $R_{yield} = S_y / S_{yn}$ accounts for the fact that the actual strength exceeds the specified material strength; $R_{sh} = S_{y4.0\%} / S_y$ accounts for the strain

hardening that was observed during cyclic and monotonic tests and $S_{y4.0\%}$ is the lateral force at 4.0% drift level. This R_o calculation approach neglected other factors that would further increase the overstrength; i.e. member oversize and development of a collapse mechanism.

2.8.4 Energy

In order to take into account the inertial effect of the mass of the loading beam and the top half of the wall equation 2.25 was used.

$$S' = S \pm \left(\frac{a \times g \times m}{1000} \right) \quad (2.25)$$

where S' is the corrected shear wall resistance; S is the measured shear wall resistance; a is the measured acceleration of the top of the wall; g is the gravity acceleration (9.81 m/s^2); m is the mass (250 kg for the loading beam + half the mass of the specimen)

All calculations were carried out with the corrected shear wall resistance S' . The latter is shown in the shear resistance versus deflection graph presented in Appendix A.

The dissipated energy for each test was defined by equation 2.25 as:

$$E = \sum_{i=1}^n \frac{S_i + S_{i+1}}{2} (\Delta_{i+1} - \Delta_i) \quad (2.26)$$

where E is the total cumulative energy; S_i is the corrected wall resistance at data point i ; Δ_i is the lateral displacement at data point i .

All graphs and test results for the monotonic and reversed cyclic CUREE tests are given in Appendix A.

2.9 MATERIAL PROPERTIES

The material properties of the steel studs, tracks, gusset plates and straps were determined from coupons tested according to ASTM A370 (2002). All elements of a test wall were fabricated from cold-formed steel coming from nine different steel coils. Three coupons were fabricated for each of the nine steel types and tested at 0.1 mm/min in the elastic range and 6 mm/min beyond the yield point. Six additional coupons were milled from each of the three steels used for the strap braces to measure the material properties under different strain rates, similar to the approach used by Al-Kharat and Rogers (2008). Three of the six coupons were tested at 50 mm/min and the remaining three at 100mm/min. This additional testing was carried out because the braces were expected to control the overall behaviour of the wall. The lowest and the highest test speeds were chosen to represent the strain rate of the monotonic and cyclic tests, respectively. The intent was to represent approximately the maximum brace strain rates of the monotonic (0.000019 s^{-1}) and 0.5 Hz reversed cyclic (0.1 s^{-1}) tests, respectively. The maximum cross head speed of the screw driven materials testing machine was 100mm/min, which did not allow for a match with the strain rate experienced by the wall braces during the largest displacement cycles. The predicted strength and stiffness properties for the monotonic and cyclic test walls were based on the yield stress F_y and base metal thickness determined from the coupon tests run at a cross-head speed of 0.1 mm/min and 100mm/min, respectively.

The material properties obtained from coupon tests are presented in Table 2.7 and Table 2.8.

Table 2.7 Material properties of strap braces

Strap Width, mm (in)	Cross-Head Rate mm/min (in/min)	Nominal Thickness mm (in)	Base Metal Thickness mm (in)	Yield Stress, F_y MPa (ksi)	Ultimate Stress, F_u (MPa) (ksi)	F_u / F_y	% Elong.	F_y / F_{yn}	Strain Rate ($\times 10^3 \text{ s}^{-1}$)
63.5 (2 1/2)	0.1 (0.004)	1.09 (0.043)	1.11 (0.044)	296 (42.8)	366 (53.0)	1.24	32.5	1.29	0.021
63.5 (2 1/2)	50 (1.97)	1.09 (0.043)	1.11 (0.044)	310 (44.9)	381 (55.2)	1.23	30.3	1.35	10.40
63.5 (2 1/2)	100 (3.94)	1.09 (0.043)	1.11 (0.044)	314 (45.4)	377 (54.6)	1.20	31.7	1.36	20.80
69.9 (2 3/4)	0.1 (0.004)	1.37 (0.054)	1.41 (0.055)	387 (56.1)	560 (81.1)	1.45	27.2	1.14	0.021
69.9 (2 3/4)	50 (1.97)	1.37 (0.054)	1.41 (0.055)	406 (58.8)	571 (82.7)	1.41	26.7	1.19	10.40
69.9 (2 3/4)	100 (3.94)	1.37 (0.054)	1.42 (0.056)	407 (58.8)	584 (84.6)	1.44	28.0	1.19	20.80
101.6 (4)	0.1 (0.004)	1.73 (0.068)	1.79 (0.070)	353 (51.1)	505 (73.2)	1.43	32.4	1.04	0.021
101.6 (4)	50 (1.97)	1.73 (0.068)	1.78 (0.070)	372 (53.9)	521 (75.5)	1.40	30.7	1.10	10.40
101.6 (4)	100 (3.94)	1.73 (0.068)	1.79 (0.070)	373 (54.1)	522 (75.5)	1.40	31.6	1.10	20.80

Table 2.8 Material properties of studs, tracks and gusset plates

Member	Cross-Head Rate mm/min (in/min)	Nominal Thickness mm (in)	Base Metal Thickness mm (in)	Yield Stress, F_y MPa (ksi)	Ultimate Stress, F_u MPa (ksi)	F_u / F_y	% Elong.	F_y / F_{yn}	Strain Rate ($\times 10^3 \text{ s}^{-1}$)
0.043" Stud	0.1 (0.004)	1.09 (0.043)	1.16 (0.046)	325 (47.1)	382 (55.3)	1.18	28.8	1.41	0.021
0.043" Track	0.1 (0.004)	1.09 (0.043)	1.11 (0.044)	296 (42.9)	366 (53.0)	1.24	32.5	1.29	0.021
0.054" Stud	0.1 (0.004)	1.37 (0.054)	1.41 (0.056)	387 (56.1)	560 (81.1)	1.45	27.2	1.14	0.021
0.054" Track	0.1 (0.004)	1.37 (0.054)	1.41 (0.056)	388 (56.1)	561 (81.1)	1.45	27.2	1.14	0.021
0.054" Gusset	0.1 (0.004)	1.37 (0.054)	1.41 (0.056)	389 (56.1)	562 (81.1)	1.45	27.2	1.14	0.021
0.054" U-Gusset	0.1 (0.004)	1.37 (0.054)	1.40 (0.055)	372 (53.9)	505 (73.2)	1.36	32.1	1.10	0.021
0.068" Stud	0.1 (0.004)	1.73 (0.068)	1.80 (0.071)	348 (50.4)	505 (73.2)	1.45	27.9	1.02	0.021
0.068" Track	0.1 (0.004)	1.73 (0.068)	1.79 (0.071)	353 (51.1)	505 (73.2)	1.43	32.4	1.04	0.021
0.068" Gusset	0.1 (0.004)	1.73 (0.068)	1.79 (0.071)	354 (51.1)	505 (73.2)	1.43	32.4	1.04	0.021
0.097" Track	0.1 (0.004)	2.46 (0.097)	2.53 (0.100)	336 (48.7)	463 (67.1)	1.38	33.8	0.99	0.021

It can be seen from the results in Table 2.7 and Table 2.8 that all the steels used in the fabrication of the tests specimens have a ratio $F_u/F_y \geq 1.08$, and the coupon elongation over 50mm gauge length is more than 10%; which is required by the

North American Specification for Cold-Formed Steel Members (*CSA, 2007; AISI, 2007*). The yield strength F_y and tensile strength F_u of the brace material were generally observed to increase as the strain rate increased; the ratio F_u/F_y exceeded the 1.2 lower limit specified in AISI S213.

2.10 OBSERVED PERFORMANCE

The desirable behaviour of all strap braced walls is gross-cross section yielding of the braces. This would likely be followed by strain hardening, and in some cases net section fracture of a strap at high storey drift, far beyond that which would be anticipated during a seismic event. To achieve this ductile response and to allow for a stable and reliable hysteretic energy-dissipation mechanism, braces were designed to reach and maintain their yield capacity while undergoing large inelastic deformations over expected lateral displacement of the test wall. All remaining elements in the SFRS (brace connections, gusset plates, chord studs, tracks, anchor rods, holddowns and shear anchors) were detailed to be able to carry the probable capacity of the brace, as described in Section 2.1.

The performance of most of the test specimens subjected to monotonic and cyclic lateral loading was governed by the yielding of the straps, and even at a lateral drift of 8% for the monotonic and 4.5% for the cyclic tests net cross-section fracture was not observed. Significant increase of the wall resistance due to strain hardening of the braces was observed above 1.2%, 1.6% and 2.5% drift for test specimens with short fuse, long fuse and regular braces, respectively. Also, an elastic bending and distortional buckling of the chord studs was observed likely due to the large drift reached at the end of all monotonic tests. Test photographs are presented in Figure 2.50 to Figure 2.62 and a summary of the failure modes is listed in Table 2.9 and detailed description of observed failure modes is given in Section 2.10.1 and 2.10.2.

Table 2.9 Summary of observed performance during braced wall testing

Specimen	Braces	Observed Performance
9C-M	Regular	Compression and bearing failure of the bottom track, yielding of braces
25A-M 1	Short fuse	Drift of over 8% reached – limited by stroke of actuator
25A-M 2 ^a	Short fuse	Yielding of braces, net section fracture at 3.6% drift
26A-C	Short fuse	Yielding of braces, net section fracture at 4.1% drift
27A-M 1	Short fuse	Yielding of braces, net section fracture at 8.6% drift
27A-M 2 ^a	Short fuse	Yielding of braces, net section fracture at 3.6% drift
28A-C	Short fuse	Drift of over 4.5% reached – limited by stroke of actuator
29A-M 1	Short fuse	Drift of over 8% reached – limited by stroke of actuator
29A-M 2 ^a	Short fuse	Yielding of braces, net section fracture at 4.6 % drift
30A-C	Short fuse	Drift of over 4.5% reached – limited by stroke of actuator
31A-M 1	Long fuse	Drift of over 8% reached – limited by stroke of actuator
31A-M 2 ^a	Long fuse	Yielding of braces, net section fracture at 4.5 % drift
32A-C	Long fuse	Drift of over 4.5% reached – limited by stroke of actuator Block shear failure of flanges of the bottom track, bending of chord studs
33 A-M 1	Long fuse	Drift of over 8% reached – limited by stroke of actuator
33A-M 2 ^a	Long fuse	Yielding of braces, net section fracture at 5.5 % drift
34A-C	Long fuse	Drift of over 4.5% reached – limited by stroke of actuator
35A-M	Regular	Yielding of braces, net section fracture at 8.0 % drift
36A-C	Regular	Block shear failure of flanges of the bottom track at 2.5 % drift, bending of chord studs, yielding of braces
37A-M	Regular	Compression and bearing failure of the bottom track, yielding of braces
38A-C	Regular	Drift of over 4.5% reached – limited by stroke of actuator
39A-M	Regular	Compression and bearing failure of the bottom track, yielding of braces Drift of over 8% reached
40A-C	Regular	Drift of over 4.5% reached – limited by stroke of actuator
41A-M	Regular	Drift of over 8% reached – limited by stroke of actuator
42A-C	Regular	Drift of over 4.5% reached – limited by stroke of actuator
43A-M	Regular	Drift of over 8% reached – limited by stroke of actuator
44A-C	Regular	Drift of over 4.5% reached – limited by stroke of actuator
45A-M	Regular	Yielding of braces, net section fracture at 7.6 % drift
46A-C	Regular	Drift of over 4.5% reached – limited by stroke of actuator
47A-M	Regular	Drift of over 8% reached – limited by stroke of actuator
48A-C	Regular	Drift of over 4.5% reached – limited by stroke of actuator

Note: Cyclic tests had regular end screw connected braces and braces with additional screws from the brace to the interior studs; ^aStraps screw connected to the interior studs

2.10.1 Observed Performance for Test Walls with Fuse Braces

All specimens having fuse braces were able to reach and maintain their yield capacity during monotonic and cyclic tests. Figure 2.50 shows a test specimen after a cyclic test. It can be seen that brace yielded and all inelastic deformation was limited to the fuse section of the brace.



Figure 2.50 Test Specimen photographs showing elongated fuse section

Only in test specimen 32A-C was a slight reduction of the wall resistance observed because of a block shear failure of the connection between the braces and the flanges of the bottom track; which caused bending of the chord studs at the bottom (Figure 2.56). To avoid this failure placement of the holddowns on the inside of the chords or the use of gusset plates is recommended. This failure was not expected nor was it observed during the monotonic test of specimen 31A-M likely due to the dynamic nature of the cyclic loading. Note, that for specimen

32A-C the bending of the bottom of the flanges was not very severe and this failure reduced the wall resistance by only a small amount.

Tests of the wall specimens where braces were attached to the framing studs with additional No.8 screws showed that the resulting holes affect the wall performance when a short fuse brace is used. Net cross section fracture of the short fuse straps with screws in the fuse for the monotonic test was observed at 3.6%, 3.6% and 4.6% drift for the light, medium and heavy walls, respectively. In the case of the long fuse configuration with screws in the fuse the light and heavy walls were able to reach 4.5% and 5.5% drift, respectively. The walls with the same fuse braces but having no additional screws were able to reach drift levels of over 8%. Based on these observations, the impact of holes on brace ductility diminishes as the fuse length is increased.



Figure 2.51 Typical wall at the end of a monotonic test (test specimen 25 A-M 1)



Figure 2.52 Distortional buckling of a chord stud of specimen 25A-M 1 (left) and net cross-section failure of a brace of specimen 25A-M 2 at 3.6% drift (right)

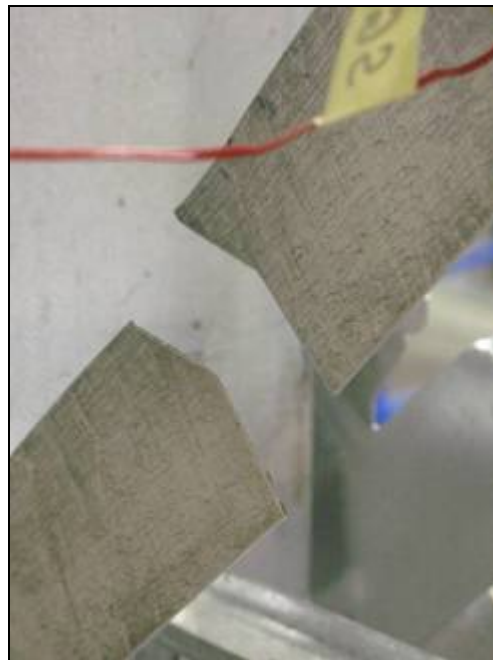

Figure 2.53 Net section fracture of braces of specimen 27A-M 1 at 8.6% drift

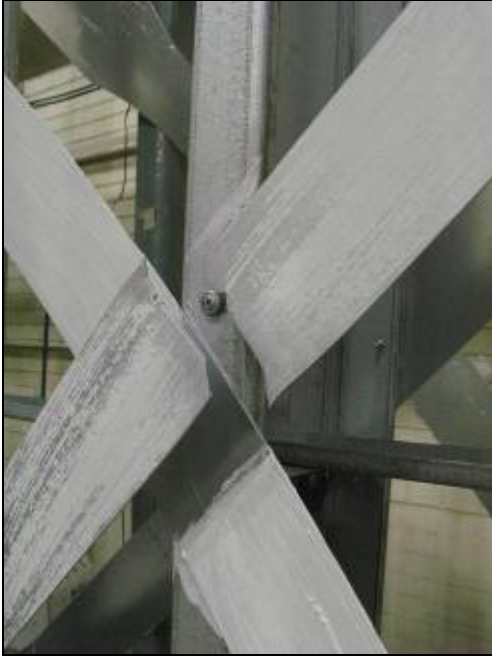

Figure 2.54 Net section fracture of braces of specimen 27A-M 2 at 3.6% drift



Figure 2.55 Lüder's band lines (left) and net cross-section failure of a brace (right) of specimen 31A-M 2 at 4.5% drift

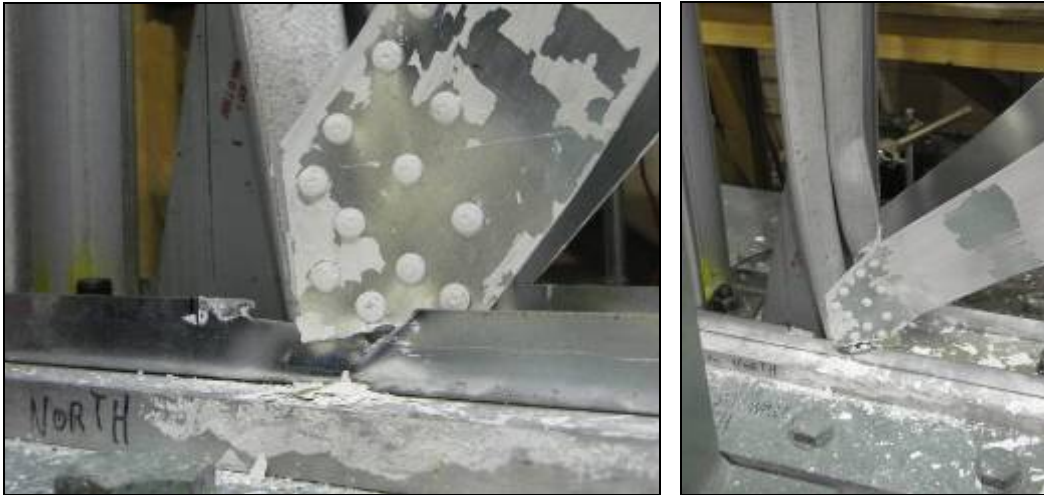

Figure 2.56 Block shear failure of flanges of the bottom track and bending of chord studs of specimen 32A-C

2.10.2 Observed Performance for Test Walls with Regular Braces

Yielding of the straps occurred in all walls braced with regular width braces. Only test specimens 9C-M, 36A-C, 37A-M and 39A-M failed in a different mode that was not expected. Walls 9C-M and 39A-M (Figure 2.61) were designed with reinforced tracks but the reinforcing track was not adequate to transfer the compression force from the tracks to the shear anchors. Walls 40A-C, 45A-M and 46A-C were constructed with a longer reinforced track section which allowed for the braces to yield because of the higher nominal compression resistance of the track. Wall 37A-M (Figure 2.60) was designed with an extended track but the holddown was placed outside of the chord studs; there was not enough space for a second shear anchor to be installed in the extended portion of the track. This resulted in the bearing failure of the track. The remaining heavy walls with extended tracks and exterior holddowns were provided with a reinforced section at the shear anchor location as illustrated in Figure 2.40. Test specimen 36A-C (Figure 2.58 and Figure 2.59) failed in a different mode: block shear failure of the connection between the braces and flanges of the bottom track, which caused bending of the chord studs and reduction of the wall resistance. As can be seen in

Figure 2.58 and Figure 2.59 the holddown in this wall configuration was raised and the braces were connected to the flanges of the chord studs and tracks with twelve No.10 wafer head screws, only three screws connected the braces to the flanges of the tracks. Also, after the cyclic test it was found that two of these three screws were placed very close to the top edge of the track flange. When the connection between the braces and flanges of the tracks failed, the load was transferred to the chord studs, which caused their bending. In order to prevent this failure mode the screws connecting the braces to the track flanges should be designed for the horizontal component of the brace force, and in this case the use of gusset plates would be necessary, so as to allow for better transfer of forces and provide more space for screws. Likely due to the dynamic nature of the cyclic loading this failure mode was not observed during the monotonic test of the identical specimen 35 A-C (Figure 2.57). Although these four specimens failed in different modes than expected, they were able to reach but not maintain a yield level load carrying capacity over extended displacement.

Net cross section fracture of the braces was observed after the braces yielded in test specimen 35A-M (Figure 2.57) and 45A-M (Figure 2.62) at drift levels of 8.0% and 7.6%, respectively. This is far beyond the maximum 2.5% inelastic drift level set by the NBCC. The fracture was located at the first row of screws at brace ends.

Tests show that specimens where U-shaped holddowns were used perform very well under monotonic and cyclic loading. The braces yielded and the maximum drift levels limited by the stroke of actuator were reached without any damage to the other elements of the SFRS. In the case of multi-storey walls the design must provide for the transfer of the vertical uplift component of the brace force from the storeys above to the foundation; this would not have been possible with these holddowns as constructed because they were not connected to the chord studs.

Test specimens 47A-M and 48A-C were fabricated with braces on one side of the wall. The monotonic and cyclic test did not show any torsional or lateral torsional buckling of the chord studs caused by the eccentric loading. The behaviour was as observed for the walls with braces on both sides.

All specimens with regular straps attached to the interior framing members using No. 8 screws had the same behaviour and lateral resistance as the specimens where braces were not attached to the framing members. Also the position of the holddown (raised or flush with the bottom of the wall) did not result in different wall behaviour except with the light walls where the block failure mode was observed. This failure could have been avoided if the holddowns had been placed inside the chord studs and flush with the base of the wall; the horizontal force would likely have transferred to the holddown and then through the anchor rod instead of going into the track. The effect of the prying force on the anchor rod due to different holddown position is presented in Appendix G.

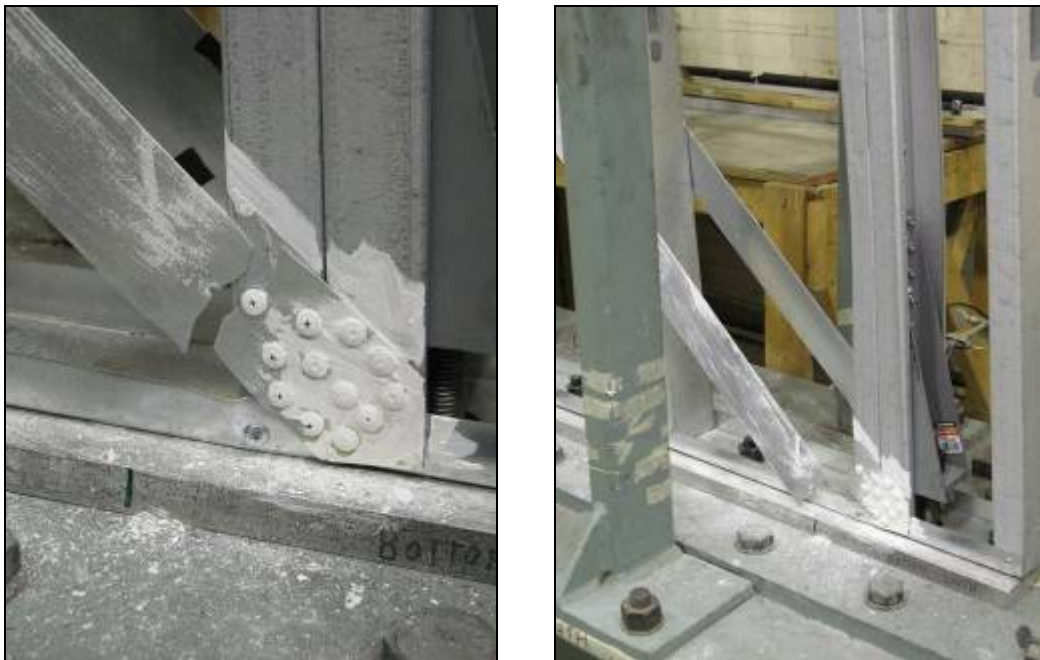

Figure 2.57 Net cross-section failure of a brace of specimen 35A-M 1 at 8% drift



Figure 2.58 Bending of chord studs of specimen 36A-C



Figure 2.59 Block shear failure of flanges of the bottom track and bending of chord studs of specimen 36A-C

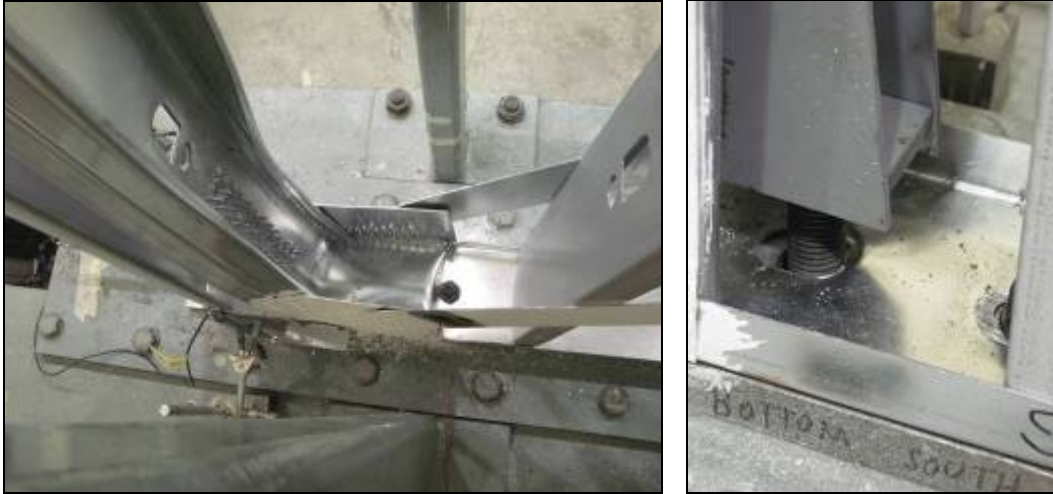

Figure 2.60 Compression and bearing failure of the bottom track of specimen 37A-M

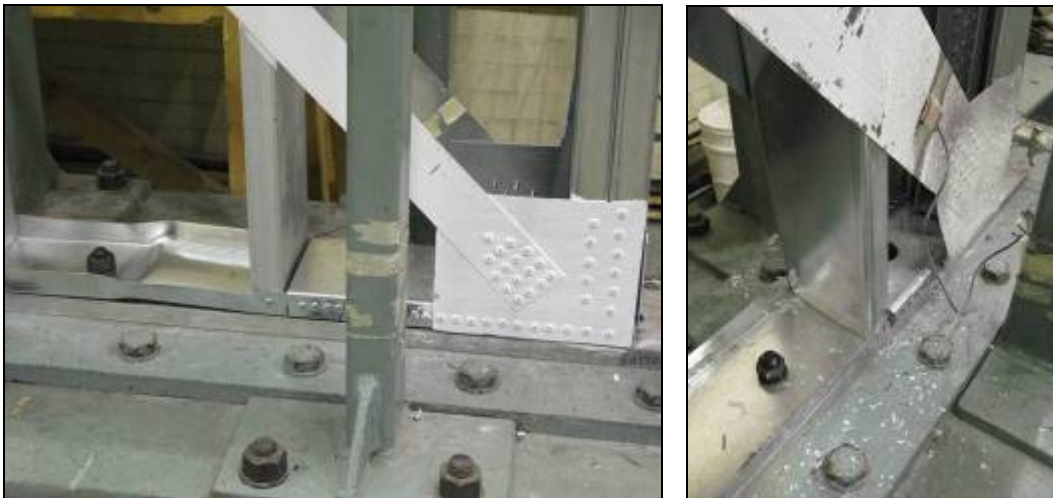

Figure 2.61 Compression and bearing failure of the bottom track of specimen 39A-M

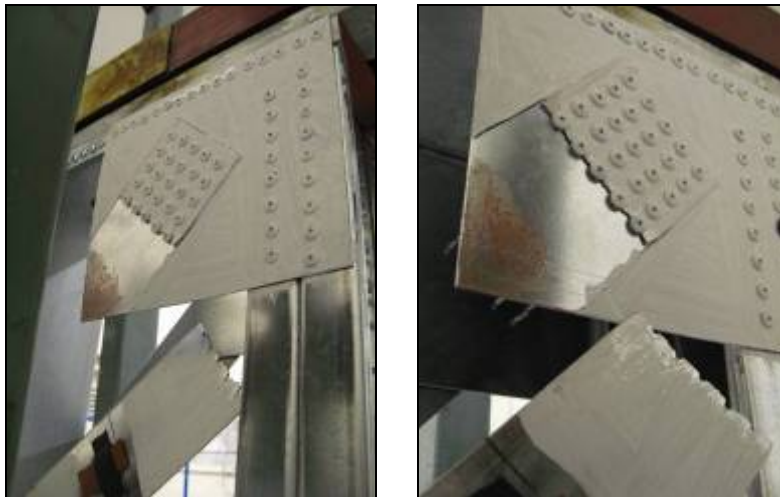

Figure 2.62 Net section fracture of braces of specimen 45A-M at 7.6% drift

2.11 SUMMARY AND DISCUSSION OF TEST RESULTS

This section contains a discussion of the monotonic and cyclic test results. A summary of the test results and the predicted wall stiffness and lateral resistance is provided in Table 2.10 through to Table 2.13. A description of all parameters and how they were obtained is provided in Section 2.8.

Table 2.10 Summary of monotonic test results

Test Specimen	K_e (kN/mm)	K_p (kN/mm)	K_n (kN/mm)	K_e/K_p	K_e/K_n	Δ_{max} (mm)	max drift (%)	Energy (Joules)
9C-M	3.38	5.08	5.14	0.67	0.66	97.8	4.01	4489
25A-M 1	2.85	3.34	3.31	0.85	0.86	210.4	8.62	7294
25A-M 2	3.10	3.34	3.31	0.93	0.94	89.2	3.66	3006
27A-M 1	4.16	5.20	5.12	0.80	0.81	210.7	8.64	14333
27A-M 2	4.09	5.20	5.12	0.79	0.80	87.5	3.59	5126
29A-M 1	6.07	7.79	7.66	0.78	0.79	201.7	8.27	21796
29A-M 2	6.47	7.79	7.66	0.83	0.84	113.6	4.66	11595
31A-M 1	2.83	3.15	3.12	0.90	0.91	216.7	8.88	7496
31A-M 2	2.64	3.16	3.12	0.83	0.85	109.3	4.48	3695
33A-M 1	6.46	7.40	7.26	0.87	0.89	213.0	8.73	22474
33A-M 2	5.79	7.40	7.26	0.78	0.80	135.2	5.54	14524
35A-M	2.40	2.78	2.75	0.86	0.87	196.0	8.03	6290
37A-M	5.52	6.13	6.02	0.90	0.92	154.6	6.34	16750
39A-M	3.06	3.90	3.81	0.79	0.80	200.4	8.21	11631
41A-M	2.57	2.79	2.76	0.92	0.93	203.6	8.35	5768
43A-M	5.05	6.79	6.65	0.74	0.76	201.8	8.27	16915
45A-M	4.66	6.18	6.07	0.75	0.77	184.8	7.58	16623
47A-M	1.75	2.09	2.04	0.84	0.86	200.7	8.22	6029

Test Specimen	S_y (kN)	S_{yp} (kN)	S_y/S_{yc}	S_y/S_{yp}	S_y/S_{yn}	μ (mm/mm)	R_d	R_o
9C-M	57.50	58.06	0.85	0.99	1.28	5.75	3.24	1.42
25A-M 1	32.40	29.60	0.96	1.09	1.44	18.48	6.00	1.89
25A-M 2	32.40	29.55	0.96	1.10	1.44	8.54	4.01	2.03
27A-M 1	57.00	53.94	1.13	1.06	1.24	15.39	5.46	1.80
27A-M 2	56.60	53.86	1.12	1.05	1.23	6.33	3.41	1.83
29A-M 1	89.60	90.97	0.96	0.98	1.06	13.67	5.13	1.53
29A-M 2	87.40	91.06	0.94	0.96	1.03	8.41	3.98	1.50
31A-M 1	31.40	29.41	0.93	1.07	1.39	19.52	6.17	1.75
31A-M 2	33.00	29.78	0.98	1.11	1.47	8.73	4.06	1.88
33A-M 1	93.80	91.24	1.01	1.03	1.11	14.66	5.32	1.46
33A-M 2	91.40	91.06	0.98	1.00	1.08	8.57	4.02	1.44
35A-M	31.60	29.46	0.94	1.07	1.40	14.89	5.36	1.64
37A-M	92.90	91.06	1.00	1.02	1.10	9.19	4.17	1.29
39A-M	56.50	54.25	1.12	1.04	1.23	10.86	4.55	1.45
41A-M	29.40	26.95	0.95	1.09	1.43	17.82	5.89	1.63
43A-M	84.60	83.81	0.98	1.01	1.08	12.05	4.81	1.28
45A-M	89.10	90.97	0.96	0.98	1.05	9.67	4.28	1.25
47A-M	28.20	27.14	1.12	1.04	1.23	12.47	4.89	1.34

Table 2.11 Summary of monotonic test results (US customary units)

Test Specimen	K_c (kips/in)	K_p (kips/in)	K_n (kips/in)	K_c/K_p	K_c/K_n	Δ_{max} (in)	max drift (%)	Energy (Joules)
9C-M	0.59	0.89	0.90	0.67	0.66	3.85	4.01	4489
25A-M 1	0.50	0.59	0.58	0.85	0.86	8.28	8.62	7294
25A-M 2	0.54	0.58	0.58	0.93	0.94	3.51	3.66	3006
27A-M 1	0.73	0.91	0.90	0.80	0.81	8.30	8.64	14333
27A-M 2	0.72	0.91	0.90	0.79	0.80	3.45	3.59	5126
29A-M 1	1.06	1.36	1.34	0.78	0.79	7.94	8.27	21796
29A-M 2	1.13	1.36	1.34	0.83	0.84	4.47	4.66	11595
31A-M 1	0.50	0.55	0.55	0.90	0.91	8.53	8.88	7496
31A-M 2	0.46	0.55	0.55	0.83	0.85	4.30	4.48	3695
33A-M 1	1.13	1.30	1.27	0.87	0.89	8.39	8.73	22474
33A-M 2	1.01	1.30	1.27	0.78	0.80	5.32	5.54	14524
35A-M	0.42	0.49	0.48	0.86	0.87	7.72	8.03	6290
37A-M	0.97	1.07	1.05	0.90	0.92	6.09	6.34	16750
39A-M	0.54	0.68	0.67	0.79	0.80	7.89	8.21	11631
41A-M	0.45	0.49	0.48	0.92	0.93	8.02	8.35	5768
43A-M	0.88	1.19	1.16	0.74	0.76	7.95	8.27	16915
45A-M	0.82	1.08	1.06	0.75	0.77	7.28	7.58	16623
47A-M	0.31	0.37	0.36	0.84	0.86	7.90	8.22	6029

Test Specimen	S_y (kips)	S_{yp} (kips)	S_y/S_{yc}	S_y/S_{yp}	S_y/S_{yn}	Δ_{max} (in/in)	R_d	R_o
9C-M	12.93	13.05	0.85	0.99	1.28	5.75	3.24	1.42
25A-M 1	7.28	6.65	0.96	1.09	1.44	18.48	6.00	1.89
25A-M 2	7.28	6.64	0.96	1.10	1.44	8.54	4.01	2.03
27A-M 1	12.81	12.13	1.13	1.06	1.24	15.39	5.46	1.80
27A-M 2	12.72	12.11	1.12	1.05	1.23	6.33	3.41	1.83
29A-M 1	20.14	20.45	0.96	0.98	1.06	13.67	5.13	1.53
29A-M 2	19.65	20.47	0.94	0.96	1.03	8.41	3.98	1.50
31A-M 1	7.06	6.61	0.93	1.07	1.39	19.52	6.17	1.75
31A-M 2	7.42	6.70	0.98	1.11	1.47	8.73	4.06	1.88
33A-M 1	21.09	20.51	1.01	1.03	1.11	14.66	5.32	1.46
33A-M 2	20.55	20.47	0.98	1.00	1.08	8.57	4.02	1.44
35A-M	7.10	6.62	0.94	1.07	1.40	14.89	5.36	1.64
37A-M	20.89	20.47	1.00	1.02	1.10	9.19	4.17	1.29
39A-M	12.70	12.20	1.12	1.04	1.23	10.86	4.55	1.45
41A-M	6.61	6.06	0.95	1.09	1.43	17.82	5.89	1.63
43A-M	19.02	18.84	0.98	1.01	1.08	12.05	4.81	1.28
45A-M	20.03	20.45	0.96	0.98	1.05	9.67	4.28	1.25
47A-M	6.34	6.10	1.12	1.04	1.23	12.47	4.89	1.34

Table 2.12 Summary of reversed cyclic test information

Test Specimen		K_e (kN/mm)	K_p (kN/mm)	K_n (kN/mm)	K_e/K_p	K_e/K_n	Δ_{max} (mm)	max drift (%)	Energy (Joules)
26A-C	-ve	3.26	3.34	3.31	0.98	0.99	116.9	4.79	11310
	+ve	3.27	3.34	3.31	0.98	0.99	116.8	4.79	
28A-C	-ve	4.48	5.20	5.12	0.86	0.88	113.8	4.66	18837
	+ve	4.45	5.21	5.12	0.85	0.87	113.7	4.66	
30A-C	-ve	7.34	7.79	7.66	0.94	0.96	113.2	4.64	29722
	+ve	7.33	7.79	7.66	0.94	0.96	113.2	4.64	
32A-C	-ve	2.93	3.16	3.12	0.93	0.94	108.3	4.44	9885
	+ve	3.30	3.16	3.12	1.05	1.06	108.5	4.45	
34A-C	-ve	6.20	7.40	7.26	0.84	0.85	113.3	4.64	27519
	+ve	5.96	7.40	7.26	0.81	0.82	113.2	4.64	
36A-C	-ve	2.69	2.78	2.75	0.97	0.98	107.4	4.40	8285
	+ve	2.72	2.78	2.75	0.98	0.99	107.7	4.41	
38A-C	-ve	5.85	6.15	6.02	0.95	0.97	113.3	4.64	27034
	+ve	5.24	6.11	6.02	0.86	0.87	113.2	4.64	
40A-C	-ve	3.09	3.89	3.81	0.79	0.81	118.4	4.85	15874
	+ve	3.19	3.90	3.81	0.82	0.84	104.0	4.26	
42A-C	-ve	3.09	2.79	2.76	1.11	1.12	107.7	4.41	8877
	+ve	3.19	2.79	2.76	1.14	1.16	107.9	4.42	
44A-C	-ve	6.35	6.83	6.65	0.93	0.95	113.2	4.64	25002
	+ve	5.84	6.83	6.65	0.86	0.88	113.3	4.64	
46A-C	-ve	5.20	6.20	6.07	0.84	0.86	112.0	4.59	24234
	+ve	5.28	6.18	6.07	0.85	0.87	112.2	4.60	
48A-C	-ve	1.75	2.10	2.04	0.84	0.86	113.3	4.64	9297
	+ve	1.94	2.09	2.04	0.93	0.95	113.3	4.64	

Test Specimen		S_{max} (kN)	S_{yp} (kN)	S_{max}/S_{ye}	S_{max}/S_{yp}	S_{max}/S_{yn}	μ (mm/mm)	R_d	R_o
26A-C	-ve	45.52	29.46	1.35	1.55	2.02	12.92	4.98	2.24
	+ve	42.53	29.64	1.26	1.43	1.89	12.90	4.98	2.10
28A-C	-ve	77.29	53.86	1.53	1.43	1.68	9.46	4.23	1.87
	+ve	79.62	53.94	1.57	1.48	1.73	9.38	4.21	1.92
30A-C	-ve	127.59	90.97	1.37	1.40	1.51	9.14	4.16	1.68
	+ve	128.85	90.88	1.39	1.42	1.52	9.13	4.15	1.69
32A-C	-ve	37.30	29.74	1.10	1.25	1.66	10.67	4.51	1.84
	+ve	38.97	29.64	1.15	1.31	1.73	12.08	4.81	1.92
34A-C	-ve	117.09	91.06	1.26	1.29	1.39	7.71	3.80	1.54
	+ve	117.97	91.06	1.27	1.30	1.40	7.41	3.72	1.55
36A-C	-ve	33.51	29.51	0.99	1.14	1.49	9.77	4.31	1.65
	+ve	35.68	29.51	1.06	1.21	1.58	9.91	4.34	1.76
38A-C	-ve	106.28	91.42	1.14	1.16	1.26	7.25	3.67	1.40
	+ve	106.70	90.25	1.15	1.18	1.26	6.57	3.49	1.40
40A-C	-ve	66.87	54.17	1.32	1.23	1.45	6.74	3.53	1.61
	+ve	64.09	54.25	1.27	1.18	1.39	6.12	3.35	1.55
42A-C	-ve	33.54	26.95	1.09	1.24	1.63	12.34	4.87	1.81
	+ve	33.76	26.95	1.09	1.25	1.64	12.78	4.96	1.82
44A-C	-ve	95.97	84.64	1.12	1.13	1.23	8.49	4.00	1.36
	+ve	96.63	84.64	1.12	1.14	1.24	7.82	3.83	1.37
46A-C	-ve	102.63	91.50	1.10	1.12	1.21	6.36	3.42	1.35
	+ve	104.67	90.97	1.13	1.15	1.24	6.51	3.47	1.37
48A-C	-ve	34.63	27.20	1.37	1.27	1.51	7.29	3.68	1.67
	+ve	34.58	27.09	1.37	1.28	1.50	8.13	3.91	1.67

Table 2.13 Summary of reversed cyclic test information (US customary units)

Test Specimen		K_c (kips/in)	K_p (kips/in)	K_n (kips/in)	K_c/K_p	K_c/K_n	Δ_{max} (in)	max drift (%)	Energy (Joules)
26A-C	-ve	0.57	0.58	0.58	0.98	0.99	4.60	4.79	11310
	+ve	0.57	0.59	0.58	0.98	0.99	4.60	4.79	
28A-C	-ve	0.78	0.91	0.90	0.86	0.88	4.48	4.66	18837
	+ve	0.78	0.91	0.90	0.85	0.87	4.48	4.66	
30A-C	-ve	1.29	1.36	1.34	0.94	0.96	4.46	4.64	29722
	+ve	1.28	1.36	1.34	0.94	0.96	4.46	4.64	
32A-C	-ve	0.51	0.55	0.55	0.93	0.94	4.26	4.44	9885
	+ve	0.58	0.55	0.55	1.05	1.06	4.27	4.45	
34A-C	-ve	1.09	1.30	1.27	0.84	0.85	4.46	4.64	27519
	+ve	1.04	1.30	1.27	0.81	0.82	4.46	4.64	
36A-C	-ve	0.47	0.49	0.48	0.97	0.98	4.23	4.40	8285
	+ve	0.48	0.49	0.48	0.98	0.99	4.24	4.41	
38A-C	-ve	1.02	1.08	1.05	0.95	0.97	4.46	4.64	27034
	+ve	0.92	1.07	1.05	0.86	0.87	4.46	4.64	
40A-C	-ve	0.54	0.68	0.67	0.79	0.81	4.66	4.85	15874
	+ve	0.56	0.68	0.67	0.82	0.84	4.09	4.26	
42A-C	-ve	0.54	0.49	0.48	1.11	1.12	4.24	4.41	8877
	+ve	0.56	0.49	0.48	1.14	1.16	4.25	4.42	
44A-C	-ve	1.11	1.20	1.16	0.93	0.95	4.46	4.64	25002
	+ve	1.02	1.20	1.16	0.86	0.88	4.46	4.64	
46A-C	-ve	0.91	1.09	1.06	0.84	0.86	4.41	4.59	24234
	+ve	0.92	1.08	1.06	0.85	0.87	4.42	4.60	
48A-C	-ve	0.31	0.37	0.36	0.84	0.86	4.46	4.64	9297
	+ve	0.34	0.37	0.36	0.93	0.95	4.46	4.64	

Test Specimen		S_{max} (kips)	S_{yp} (kips)	S_{ma}/S_{ye}	S_{ma}/S_{yp}	S_{ma}/S_{yn}	δ_{max} (in/in)	R_d	R_o
26A-C	-ve	10.23	6.62	1.35	1.55	2.02	12.92	4.98	2.24
	+ve	9.56	6.66	1.26	1.43	1.89	12.90	4.98	2.10
28A-C	-ve	17.38	12.11	1.53	1.43	1.68	9.46	4.23	1.87
	+ve	17.90	12.13	1.57	1.48	1.73	9.38	4.21	1.92
30A-C	-ve	28.69	20.45	1.37	1.40	1.51	9.14	4.16	1.68
	+ve	28.97	20.43	1.39	1.42	1.52	9.13	4.15	1.69
32A-C	-ve	8.39	6.69	1.10	1.25	1.66	10.67	4.51	1.84
	+ve	8.76	6.66	1.15	1.31	1.73	12.08	4.81	1.92
34A-C	-ve	26.32	20.47	1.26	1.29	1.39	7.71	3.80	1.54
	+ve	26.52	20.47	1.27	1.30	1.40	7.41	3.72	1.55
36A-C	-ve	7.53	6.63	0.99	1.14	1.49	9.77	4.31	1.65
	+ve	8.02	6.63	1.06	1.21	1.58	9.91	4.34	1.76
38A-C	-ve	23.89	20.55	1.14	1.16	1.26	7.25	3.67	1.40
	+ve	23.99	20.29	1.15	1.18	1.26	6.57	3.49	1.40
40A-C	-ve	15.03	12.18	1.32	1.23	1.45	6.74	3.53	1.61
	+ve	14.41	12.20	1.27	1.18	1.39	6.12	3.35	1.55
42A-C	-ve	7.54	6.06	1.09	1.24	1.63	12.34	4.87	1.81
	+ve	7.59	6.06	1.09	1.25	1.64	12.78	4.96	1.82
44A-C	-ve	21.58	19.03	1.12	1.13	1.23	8.49	4.00	1.36
	+ve	21.72	19.03	1.12	1.14	1.24	7.82	3.83	1.37
46A-C	-ve	23.07	20.57	1.10	1.12	1.21	6.36	3.42	1.35
	+ve	23.53	20.45	1.13	1.15	1.24	6.51	3.47	1.37
48A-C	-ve	7.79	6.12	1.37	1.27	1.51	7.29	3.68	1.67
	+ve	7.77	6.09	1.37	1.28	1.50	8.13	3.91	1.67

2.11.1 Test Walls with Fuse Braces

This section summarises the test results for the walls that were constructed with fuse braces. The description will be in the following order: behaviour of the specimens that were detailed following capacity based design under the monotonic and cyclic loading, commentary on measured and predicted resistance and stiffness and commentary of the design procedure for diagonal strap bracing and verification of R_d and R_o values in AISI S213 (2007).

The typical monotonic and cyclic resistance vs. deflection behaviour of CFS strap braced walls having fuse braces is presented in Figure 2.63 to Figure 2.65. As can be seen in these figures the specimens were able to reach and maintain their yield strength, with strain hardening, in the inelastic range of deformation which allowed a high levels of energy dissipation to be reached. During the tests none of the SFRS elements except the fuse section of the braces were seriously damaged or fractured, except for test 32A-C. Note, slight damage at the brace connection was observed only in test specimen 32A-C, the full description and explanation of the observed failure is given in Section 2.10.1. Yielding of the fuse section was the expected behaviour, which was achieved due to the use of the capacity design principles found in AISI S213 (2007). Figure 2.63 illustrates the different behaviour of walls when braces were attached to the interior framing studs with screws. The braces that were attached with screws fractured at approximately half of the storey drift measured for the wall in which the straps were not connected to the interior studs. The installation of screws to the fuse section caused strain hardening to take place at much smaller drift levels than in the walls in which no additional screws were placed. All monotonic specimens without additional screws reached a Δ_{max} value above 8% drift. This level of displacement exceeds that which would typically be expected during a design level earthquake. Figure 2.64 and Figure 2.65 provide the wall resistance versus deflection response of representative reversed cyclic tests. None of the specimens subjected to cyclic loading exhibited brace fracture even when additional screws were installed, however drifts of up to approximately 4.5% were applied whereas the monotonic

tests were pushed to above 8% drift. Given these observations it is recommended that the reduced fuse section of the brace be treated as a protected zone in which additional screws and holes are not installed; however the impact of the brace ductility diminished as the fuse length was increased. Note, the slight reduction of the wall resistance of test specimen 32A-C (Figure 2.65) was caused by damage at the connection between the braces and the flanges of the bottom track (Section 2.10.1).

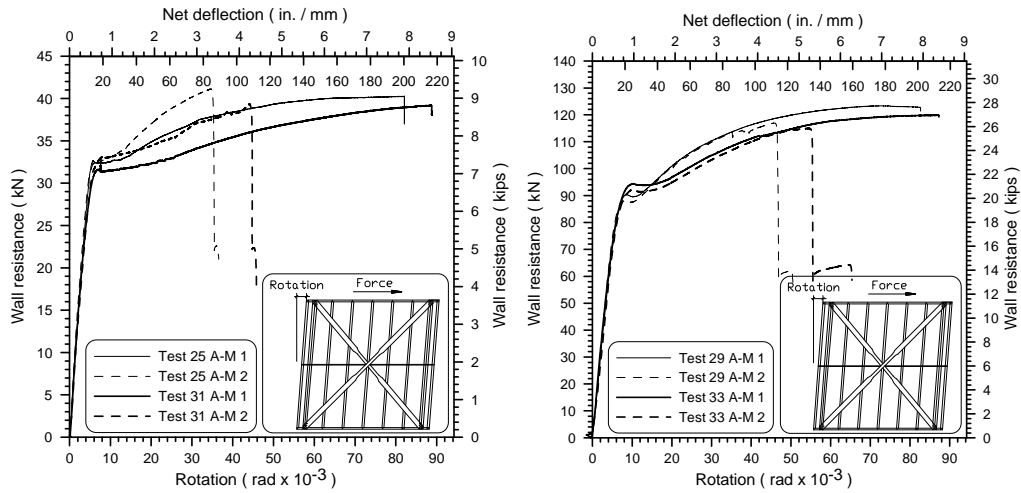

Figure 2.63 Monotonic resistance light and heavy fuse strap braced walls

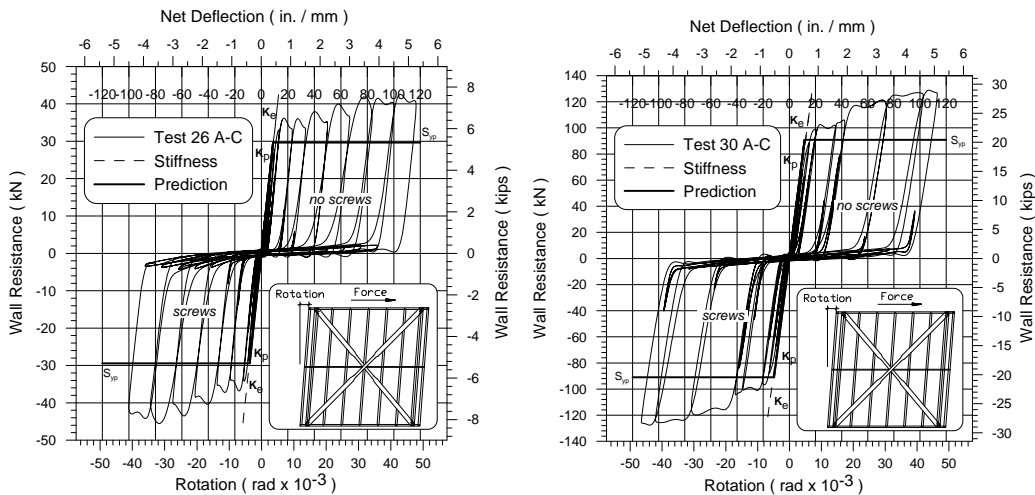

Figure 2.64 Cyclic resistance light and heavy short fuse strap braced walls

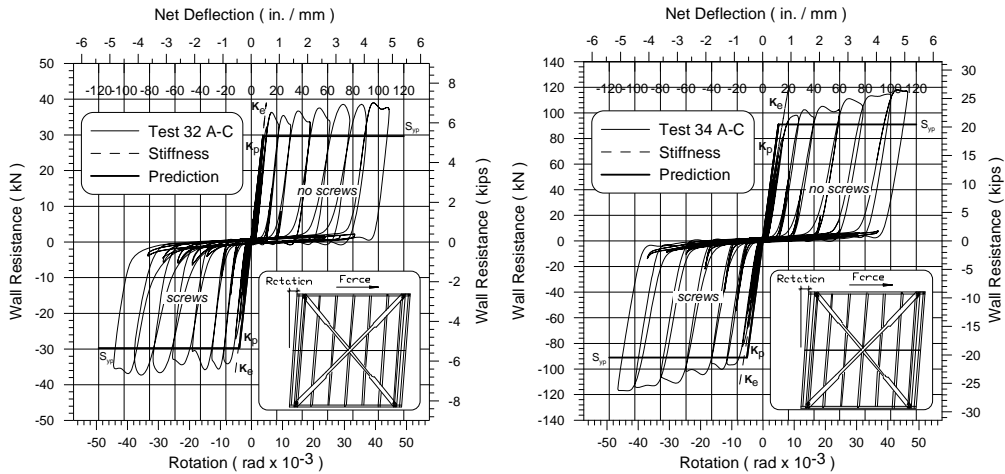

Figure 2.65 Cyclic resistance light and heavy long fuse strap braced walls

The predicted elastic lateral wall stiffness and resistance were reasonably accurate (Table 2.10 and Table 2.12). In order to improve the stiffness prediction the axial stiffness of the connection, holddown and its anchor rod should be included, otherwise using only the axial stiffness of the braces tends to overestimate the in-plane stiffness of the wall. The ratio S_y/S_{yc} , S_y/S_{yp} and S_y/S_{yn} for monotonic test are given in Table 2.10. The ratio S_y/S_{yp} is very close to unity (it varies from 0.99 to 1.11), and it demonstrates that the assumption of pin connections for chord and interior studs, and brace connections were appropriate. The ratio S_y/S_{yc} is also close to unity (it varies from 0.93 to 0.98 for light walls, 1.12 to 1.13 for medium walls and 0.94 to 1.01 for heavy walls). This shows that the value of R_y listed in AISI S213 gives good approximation of the expected yield load, but more tests are required because the brace material was obtained from only three different coils, which may not reflect the characteristics of steel sheet as a whole. The three ratios S_{max}/S_{yc} , S_{max}/S_{yp} and S_{max}/S_{yn} (Table 2.12) for cyclic tests are higher than the monotonic ones. This is mainly due to the strain hardening and the effect of strain rate that was included in the S_{max} .

The calculated seismic force modification factors exceeded $R_d=2.0$ and $R_o=1.3$ that are currently listed for limited ductility walls in AISI S213 (2007).

2.11.2 Test Walls with Regular Braces

This section summarises the test results for the walls that were constructed with regular braces. The description will be in the following order: behaviour of the specimens that were detailed following capacity based design, commentary on measured and predicted resistance and stiffness and commentary of the design procedure for diagonal strap bracing and verification of R_d and R_o values in AISI S213 (2007).

The typical resistance vs. deflection behaviour of CFS strap braced walls braced with regular braces subjected to monotonic and cyclic loading is presented in Figure 2.67 to Figure 2.69. As can be seen in these figures the specimens were able to reach and maintain their yield resistance in the inelastic range of deformation which allowed a high levels of energy dissipation to be reached. The degree of strain hardening was less than that observed for the fuse braced walls, because plastic straining took place over the full length of the brace and not just the short fuse section. In general, none of the SFRS elements except the braces were seriously damaged or fractured during the tests. Note, some damage was observed during the tests of specimens 9C-M, 36A-C, 37A-M and 39A-M. The full description and explanation of the observed failures is given in Section 2.10.2. Otherwise, the behaviour of the walls was as expected due to use of the capacity design principles found in AISI S213 (2007). Figure 2.66 illustrates the behaviour of a light wall with straps attached to the chord studs. During the cyclic test a failure at the brace connection caused bending of the bottom ends of the chord studs which resulted in the reduction of the wall resistance and ductility. Two of the braces (both acting in the same loading direction) of all cyclic test walls were attached with screws to the interior framing studs in order to identify where placing additional screw holes would affect the inelastic performance. A change in wall behaviour was not observed when the additional screws were installed. Figure 2.66 to Figure 2.69 and Table 2.10 and Table 2.12 illustrate how the ultimate displacement of all the test walls Δ_{max} exceeded the 4% drift level. This level of displacement exceeds that which would typically be expected during a design level earthquake. None of the specimens subjected to cyclic loading exhibited brace

fracture even when additional screws were installed. The light and heavy wall specimens where U-shaped holddowns were used performed as was expected (Figure 2.67 and Figure 2.68). The wall specimens with reinforced tracks were able to take the compression force and transfer it to the shear anchors only when the reinforced section was of sufficient length, i.e. when the first two sections of the wall track were reinforced.

The predicted elastic lateral wall stiffness and resistance for the walls with regular braces were reasonably accurate (Table 2.10 and Table 2.12). In order to improve the stiffness prediction the axial stiffness of the connection, holddown and its anchor rod should be included, otherwise using only the axial stiffness of the braces tends to overestimate the in-plane stiffness of the wall. The ratios S_y/S_{yc} , S_y/S_{yp} and S_y/S_{yn} for monotonic test walls with regular braces are given in Table 2.10. The two ratios S_y/S_{yp} and S_y/S_{yc} are close to unity and the results are similar to those for fused braces. The three ratios S_{max}/S_{yc} , S_{max}/S_{yp} and S_{max}/S_{yn} (Table 2.12) for cyclic test walls with regular braces are lower than the same ratios for walls with fuse braces mainly because the lower strain hardening observed in these specimens.

The design of regular braces followed the recommendations of AISI S213 (2007) where the nominal net-section tensile resistance of the brace member must exceed the expected yield capacity. This was achieved with the special placement of the screws. The tests showed that all braces performed as was anticipated. Also, the calculated seismic force modification factors exceeded $R_d = 2.0$ and $R_o = 1.3$ that are currently listed in AISI S213 (2007). Note, only the heavy walls 37A-M, 43A-M, 45A-M provided R_o values that were slightly less than 1.3. This can be attributed to the low ratio of F_y / F_{yn} of the braces which was only 1.04, when on average a ratio of 1.10 is expected for this grade of steel (Table 2.7).

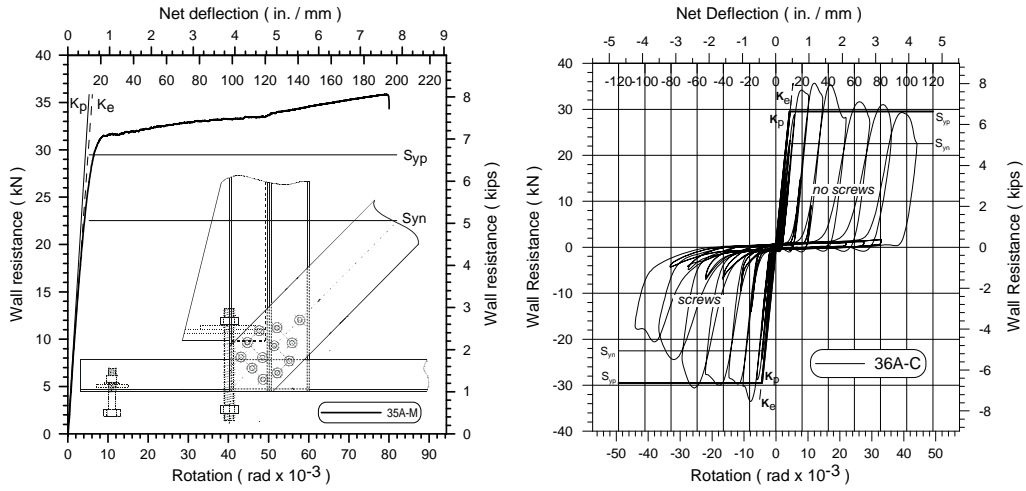

Figure 2.66 Monotonic and cyclic resistance vs. deflection for light walls

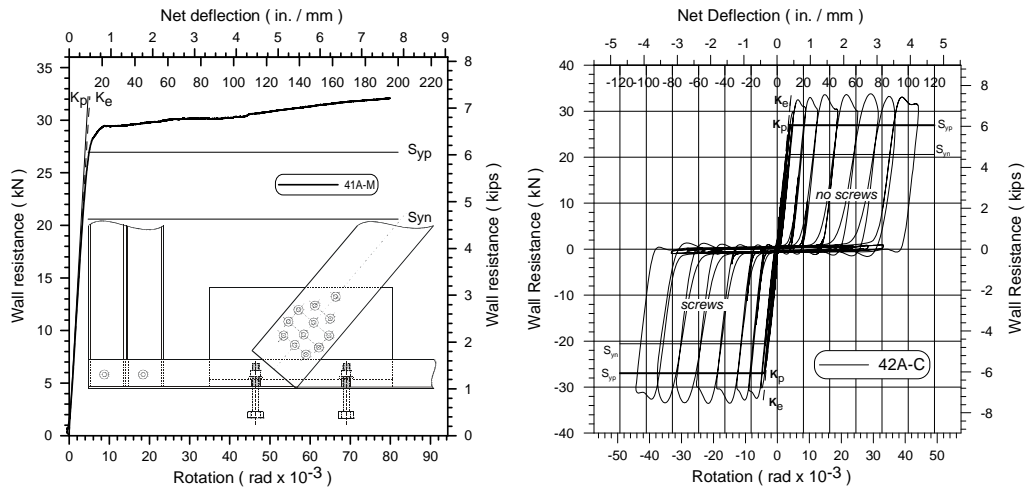

Figure 2.67 Monotonic and cyclic resistance vs. deflection for light walls with U-shaped holddown

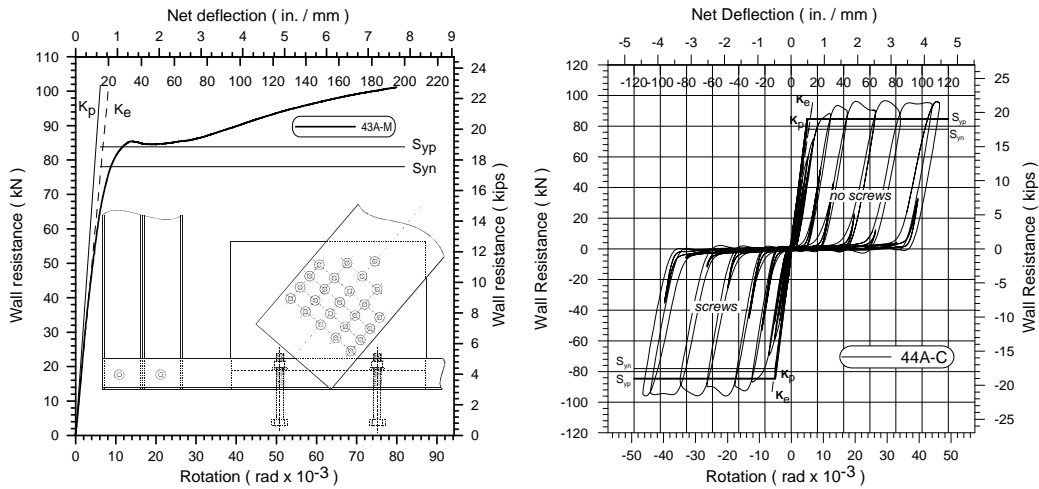

Figure 2.68 Monotonic and cyclic resistance vs. deflection for heavy walls with U-shaped holddown

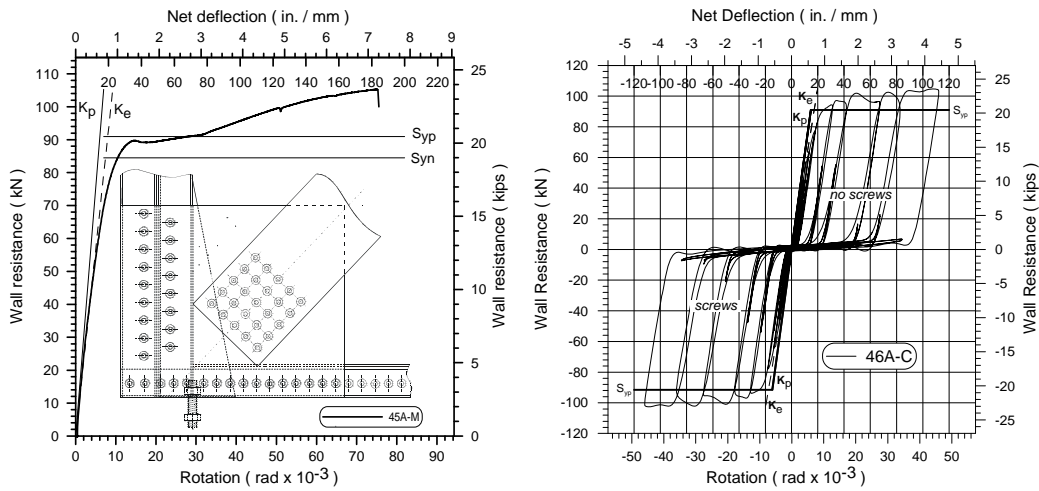

Figure 2.69 Monotonic and cyclic resistance vs. deflection for heavy walls with reinforced track

Chapter 3 Dynamic Analyses

3.1. INTRODUCTION

In order to evaluate the current seismic force modification factors and height limits given in AISI S213 (2007) dynamic analyses was carried out for conventional construction braced wall systems situated in various seismic zones in Canada. The nonlinear time history dynamic analysis program RUAUMOKO (Carr, 2000) was chosen to model and analyse the seismic force resisting system (SFRS) of representative residential buildings that were designed following the 2005 NBCC equivalent static force procedure. The results from these analyses were used to evaluate the inelastic behaviour under earthquake loading of multi-storey buildings that are braced by tension only cold-formed steel strap bracing bents. This chapter contains a presentation on the bracing bent design, the hysteretic element calibration, the choice of uniform hazard spectrum (UHS) compatible earthquake time histories, and the nonlinear dynamic analyses, incremental dynamic analyses and fragility curve evaluation that were carried out following the procedure described in ATC-63 (2008) modified for use with Canadian design philosophy.

3.2. DESIGN OF BUILDING MODELS

3.2.1. Building description

Typically, cold-formed steel strap braced walls are used in low to mid-rise buildings. In order to evaluate the behaviour of these structures under earthquake loading the seismic force resisting system (SFRS) of two, four and five-storey representative residential buildings assumed to be located in Calgary, AB, Halifax, NS, Quebec, QC and Vancouver, BC, was designed according to the 2005 NBCC. An elevation and a typical floor plan of the representative building are shown in Figure 3.1.



Figure 3.1 West elevation and plan view of the representative building (Cobeen et al., 2007), mm (ft)

The representative building is rectangular in plan and it has an approximate floor area of 220 m². It is symmetrical and without any irregularities, so only earthquakes in the E-W direction were considered. Only one braced bent was taken out of the building, modeled and analyzed because the building was symmetrical and floors were assumed to act as rigid diaphragms. The SFRS was not design for wind loads. The height limit proposed for this type of structure (15 m) is slightly exceeded by the five storey buildings. The location and dimensions of the braced bents are shown in Figure 3.2 and Figure 3.3, respectively.

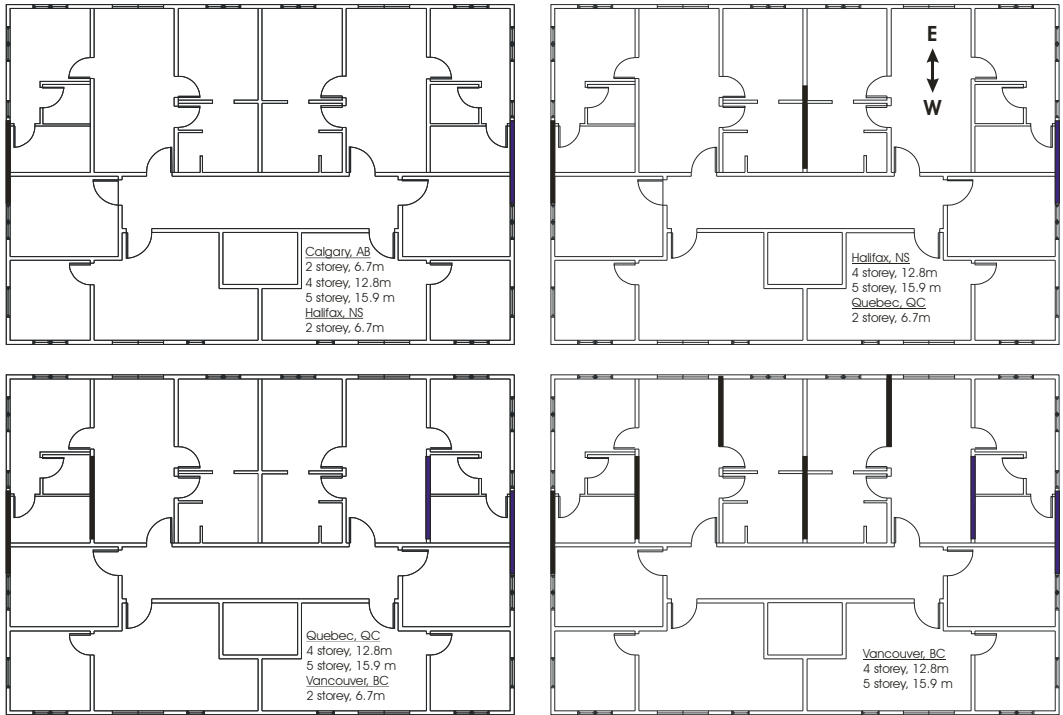

Figure 3.2 Plan view and location of braced bents (Cobeen et al., 2007)

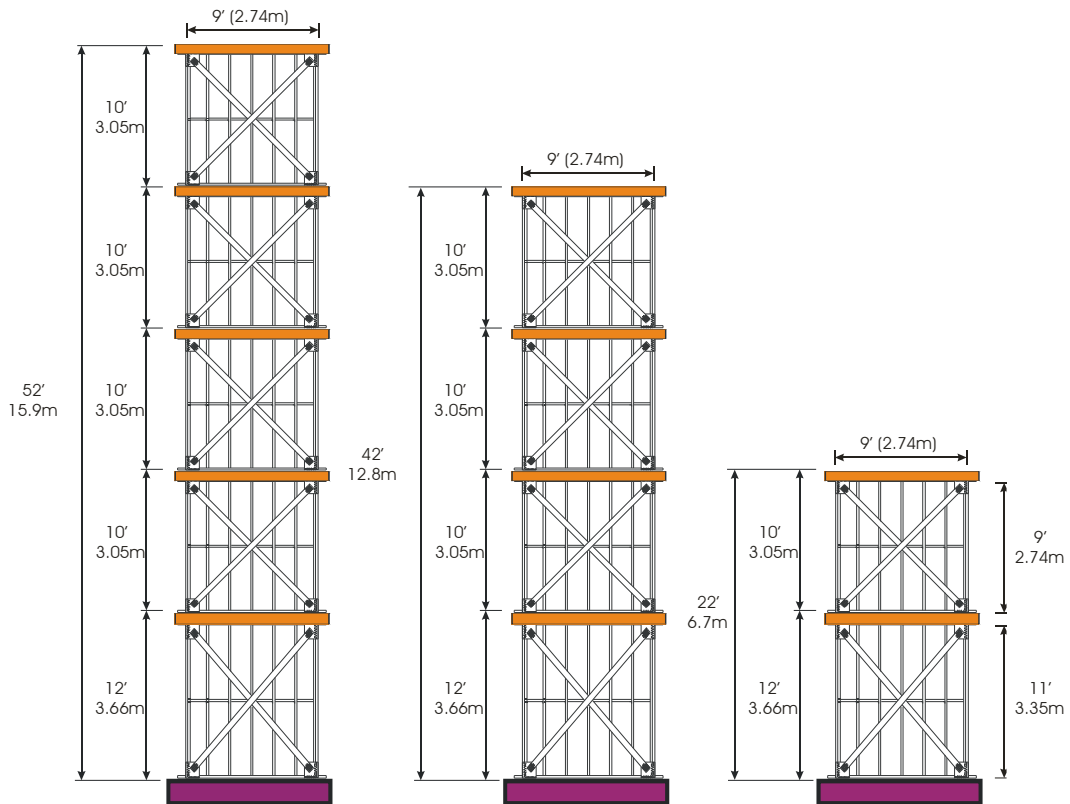

Figure 3.3 Schematics of the braced bents

The four cities were selected because the short period spectral acceleration adjusted for type *C* soil conditions ($I_E F_a S_a(0.2)$) falls within the ranges identified in Table 4.1.8.9 of the 2005 NBCC, as illustrated in Table 3.1. Also, currently AISI S213 (2007) limits the building height of conventional structures to 15m in the two lower seismic zones, while they are not permitted in the higher seismic zones.

Table 3.1 Short period spectral acceleration categories in 2005 NBCC and AISI S213

City	$I_E F_a S_a(0.2)^a$	$I_E F_v S_a(1.0)^a$	Height Limit
Calgary	0.15 < 0.2	0.041 < 0.3	15 m (49')
Halifax	0.20 < 0.23 < 0.35	0.069 < 0.3	15 m (49')
Quebec	0.35 < 0.59 < 0.75	0.14 < 0.3	Not Permitted
Vancouver	0.75 < 0.94	0.33 > 0.3	Not Permitted

^a For site class “C” and $I_E = 1$

The strap braces were designed for the most unfavourable effect of the load combinations given in Table 4.1.3.2 of the NBCC which was considered to be load case 5 (Equation 3.1) because the buildings are subjected to earthquake loading.

$$1.0D + 1.0E + 0.5L + 0.25S \quad (3.1)$$

where *D* is the specified dead load, *E* is the specified earthquake load, *L* is the specified live load, and *S* is the specified snow load. The determination of the gravity and seismic loads is presented in the following two sections.

3.2.2. Gravity loads

The specified dead loads for the roof, walls and floors were taken from the Handbook of Steel Construction, 9th Edition (CISC, 2006). The representative building was considered to be a structure of 12.14 m x 18.10 m with a cold-formed steel frame and a Hambro[®] floor system (Canam Group, 2004) (Figure 3.4). The weights of the structural and non-structural components of the building are given in Table 3.2.

Table 3.2 Dead loads

<i>Roof</i>				
Sheathing (3/4in plywood)	0.10	kPa	2.09	psf
Insulation (100mm blown fiber glass)	0.04	kPa	0.84	psf
Ceiling (12.5mm Gypsum)	0.10	kPa	2.09	psf
Joists (light gauge steel @600mm o/c)	0.12	kPa	2.51	psf
Sprinkler system	0.03	kPa	0.63	psf
Roofing (3ply + gravel)	0.27	kPa	5.64	psf
Mechanical	0.03	kPa	0.63	psf
Total	0.69	kPa	14.4	psf

<i>Interior Floors</i>				
Walls (interior & exterior)	0.72	kPa	15.0	psf
Flooring (25mm hardwood)	0.19	kPa	4.0	psf
Concrete Slab (Hambro system)	1.77	kPa	37.0	psf
Acoustic Tile (12mm)	0.04	kPa	0.8	psf
Joists (cold-formed steel @600mm o/c)	0.12	kPa	2.5	psf
Mechanical	0.03	kPa	0.6	psf
Total	2.87	kPa	60.0	psf

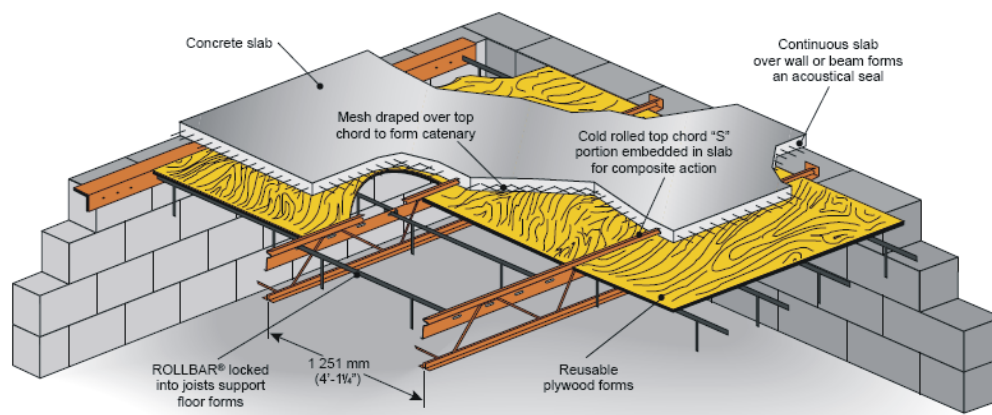

Figure 3.4 Hambro® D500 floor system (Canam Group, 2004)

Table 3.3 lists the roof snow loads, as calculated using the 2005 NBCC, for the four Canadian cities. The specified uniformly distributed live load on an area of floor for residential areas is 1.9 kPa, NBCC (2005).

Table 3.3 Snow Load as prescribed by the 2005 NBCC

City	Calgary	Halifax	Quebec	Vancouver
S_s = Snow Load (1/50yr), kPa (psf)	1.1 (23.0)	1.9 (39.7)	3.6 (75.2)	1.8 (37.6)
S_r = Rain Load (1/50yr), kPa (psf)	0.1 (2.1)	0.6 (12.5)	0.6 (12.5)	0.2 (4.2)
I_s = Importance Factor	1.0	1.0	1.0	1.0
C_b = Basic Roof Snow Load Factor	0.8	0.8	0.8	0.8
C_w = Wind Exposure Factor	1.0	1.0	1.0	1.0
C_s = Roof Slope Factor (flat roof)	1.0	1.0	1.0	1.0
C_a = Accumulation Factor	1.0	1.0	1.0	1.0
$S = I_s [S_s (C_b C_w C_s C_a) + S_r]$ Snow Load, kPa (psf)	0.98 (20.5)	2.12 (44.3)	3.48 (72.7)	1.64 (34.3)

3.2.3. Seismic loads

In order to determine the seismic loads the equivalent static force procedure described in the 2005 NBCC was followed. All structures were assumed to be located on very dense soil and soft rock in the four selected Canadian cities; Calgary, Halifax, Quebec and Vancouver. Therefore the site classification is “C” and the acceleration-based and velocity-based site coefficients are $F_a = 1$ and $F_v = 1$. The design spectral response acceleration $S(T)$ and the 5% damped spectral response accelerations, $S_a(0.2)$, $S_a(0.5)$, $S_a(1.0)$, and $S_a(2.0)$ are given in Table 3.4. The empirical fundamental lateral period of vibration, T_a , for braced frames according to the NBCC is:

$$T_a = 0.025h_n \quad (3.2)$$

where h_n is the height of the structure in metres. The design spectral acceleration $S(T_a)$ was calculated using linear interpolation. The fundamental period of vibration of the structure (Table 3.4) was also determined using RUAUMOKO; following the recommendation of the NBCC this calculated elastic period of vibration cannot be taken greater than $2T_a$. The earthquake importance factor I_E is typically taken as 1.0 for this type of residential building. Also, the factor for higher mode effects M_v depends on the ratio of $S_a(0.2) / S_a(2.0)$, the value of T_a , and the type of the lateral resisting system. Because for all considered structures $T_a < 1.0s$ (Table 3.4) for this case $M_v = 1.0$. For this conventional diagonal strap

braced wall AISI S213 (2007) prescribes $R_d = 1.25$ and $R_o = 1.30$. The seismic base shear V is given as:

$$V = \frac{S(T_a)M_v I_E W}{R_d R_o} \quad (3.3)$$

and it shall not be less than:

$$V_{\min} = \frac{S(0.2)M_v I_E W}{R_d R_o} \quad (3.4)$$

or greater than:

$$V_{\max} = \frac{2}{3} \frac{S(2.0)I_E W}{R_d R_o} \quad (3.5)$$

where W is the seismic weight of the structure which is equal to the dead load of the structure plus 25% of the snow load.

The portion of the design base shear V concentrated at the top of the building that accounts for the higher mode effects is determined by:

$$F_t = 0.07T_a V \quad (3.6)$$

when $T_a > 0.7s$ and $F_t = 0$ if $T_a \leq 0.7s$; also F_t need not be taken greater than $0.25V$. The base shear force V was distributed over the height of the building according to the following equation:

$$F_x = \frac{(V - F_t)W_x h_x}{\sum_{i=1}^n W_i h_i} \quad (3.7)$$

where F_x is the lateral force applied to level x , W_i and W_x are the portion of W that is located at level i or x respectively, h_i and h_x are the height above the base to level i or x respectively.

To account for the torsional effects the torque T_x was determined as:

$$T_x = F_x(e_x + 0.10D_{nx}) \quad (3.8)$$

where e_x and D_{nx} are based on the dimensions and layout of the bracing bents as illustrated in Figure 3.5. It was assumed that the structure is symmetric for the buildings, thus $e_x = 0$, and the additional torsional force was computed as:

$$F_{tor} = \frac{T_x}{D_{nx}} = \frac{F_x(e_x + 0.10D_{nx})}{D_{nx}} = 0.1F_x \quad (3.9)$$

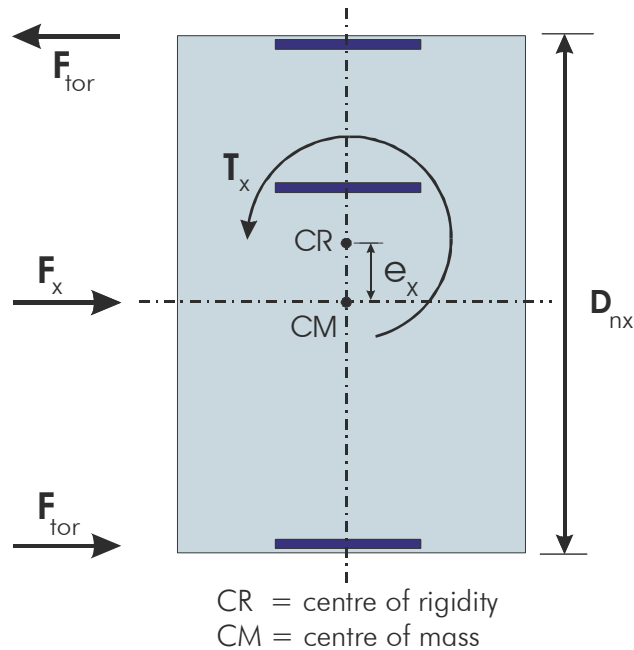

Figure 3.5 Torsional effects

The storey shear force is determined as the sum of F_t , F_x , F_{tor} , and the notional load. The latter was determined as $0.005W$, as it is prescribed by CSA S16 (2003). All calculations are summarized in Table 3.4.

Table 3.4 Lateral load calculations

City	Calgary, AB			Halifax, NS			Quebec, QC			Vancouver, BC		
Number of storeys	2	4	5	2	4	5	2	4	5	2	4	5
Height, h_n (m)	6.7	12.8	15.9	6.7	12.8	15.9	6.7	12.8	15.9	6.7	12.8	15.9
Number of braced walls	2	2	2	2	3	3	3	4	4	4	7	7
$T_a = 0.025h_n$ (s) ^a	0.17	0.32	0.40	0.17	0.32	0.40	0.17	0.32	0.40	0.17	0.32	0.40
$2 \times T_{av}$ (s) ^b	0.34	0.64	0.80	0.34	0.64	0.80	0.34	0.64	0.80	0.34	0.64	0.80
Fundamental period, T (s)	0.85	1.39	1.69	0.74	1.17	1.39	0.53	0.85	1.03	0.41	0.56 ^c	0.67 ^c
$S(T_a)$	0.12	0.07	0.06	0.19	0.11	0.09	0.46	0.26	0.21	0.81	0.60	0.54
$S_d(0.2)$	0.15			0.23			0.59			0.94		
$S_d(0.5)$	0.084			0.13			0.3			0.64		
$S_d(1.0)$	0.041			0.069			0.14			0.33		
$S_d(2.0)$	0.023			0.019			0.048			0.17		
Seismic weight per floor, W_i (kN)	1 st	630.6	630.6	630.6	630.6	630.6	630.6	630.6	630.6	630.6	630.6	630.6
	2 nd	205.5	630.6	630.6	268.1	630.6	630.6	342.8	630.6	630.6	241.7	630.6
	3 rd	-	630.6	630.6	-	630.6	630.6	-	630.6	630.6	-	630.6
	4 th	-	205.5	630.6	-	268.1	630.6	-	342.8	630.6	-	241.7
	5 th	-	-	205.5	-	-	268.1	-	-	342.8	-	-
Seismic weight for the structure, W (kN)	836.1	2097.3	2727.9	898.7	2159.9	2790.5	973.4	2234.6	2865.2	872.3	2133.5	2764.1
Base shear, (kN) $V = \frac{S(T_a)M_e I_e W}{R_d R_o}$	61.7	90.3	100.7	105.1	146.2	154.6	275.5	357.5	370.3	434.8	787.8	918.5
Minimum base shear, (kN) $V_{min} = \frac{S(2.0)M_e I_e W}{R_d R_o}$	11.8	29.7	38.6	10.5	25.3	32.6	28.8	66.0	84.6	91.3	223.2	289.2
Maximum base shear, (kN) $V_{max} = \frac{2S(0.2)I_e W}{3 R_d R_o}$	51.5	129.1	167.9	84.8	203.8	263.3	235.6	540.9	693.5	336.4	822.8	1066.0
Design base shear, (kN) $V_{min} \leq V \leq V_{max}$	51.5	90.3	100.7	84.8	146.2	154.6	235.6	357.5	370.3	336.4	787.8	918.5
$F_t = 0.07T_a V$, $T_a \geq 0.7s$ $F_t = 0$, $T_a < 0.7s$, (kN)	0.0	0.0	5.6	0.0	0.0	8.6	0.0	0.0	20.6	0.0	0.0	0.0
Lateral force per storey, (kN) $F_x = \frac{(V - F_t)W_x h_x}{\sum_{i=1}^n W_i h_i}$	1 st	32.2	14.0	9.0	47.7	21.5	14.1	118.0	47.4	30.3	197.6	115.8
	2 nd	19.2	25.6	16.4	37.1	39.4	25.9	117.6	86.9	55.5	138.8	212.3
	3 rd	-	37.3	23.9	-	57.3	37.6	-	126.4	80.8	-	308.8
	4 th	-	15.9	31.4	-	32.0	49.4	-	90.2	106.6	-	155.4
	5 th	-	-	18.1	-	-	35.0	-	-	91.6	-	-
Force due to torsion, (kN) $F_{tor} = 0.1F_x$	1 st	3.2	1.4	0.9	4.8	2.2	1.4	11.8	4.7	3.0	19.8	11.6
	2 nd	1.9	2.6	1.6	3.7	3.9	2.6	11.8	8.7	5.6	13.9	21.2
	3 rd	-	3.7	2.4	-	5.7	3.8	-	12.6	8.1	-	30.9
	4 th	-	1.6	3.1	-	3.2	4.9	-	9.0	10.7	-	15.5
	5 th	-	-	1.8	-	-	3.5	-	-	9.2	-	-
Shear force per storey, (kN)	1 st	61.8	115.8	126.6	98.8	179.0	196.4	265.1	400.3	419.1	375.5	885.3
	2 nd	22.2	96.2	112.5	42.2	151.2	176.7	131.1	344.0	381.6	153.9	753.7
	3 rd	-	63.8	90.2	-	103.7	144.0	-	244.2	316.3	-	516.0
	4 th	-	18.6	59.7	-	36.5	98.4	-	100.9	223.3	-	172.1
	5 th	-	-	21.0	-	-	39.8	-	-	102.4	-	-
Factored force per brace, (kN)	1 st	24.4	45.7	50.0	39.0	47.1	51.7	69.8	79.0	82.7	74.1	99.9
	2 nd	7.8	34.0	39.8	14.9	35.6	41.6	30.9	60.8	67.5	27.2	76.1
	3 rd	-	22.6	31.9	-	24.4	33.9	-	43.2	55.9	-	52.1
	4 th	-	6.6	21.1	-	8.6	23.2	-	17.8	39.5	-	17.4
	5 th	-	-	7.4	-	-	9.4	-	-	18.1	-	-

^a Clause 4.1.8.11. 3b NBCC, ^b Clause 4.1.8.11. 3d NBCC, ^c Braces designed for the fundamental period

Table 3.5 Lateral load calculations (US customary units)

City	Calgary, AB			Halifax, NS			Quebec, QC			Vancouver, BC		
	2	4	5	2	4	5	2	4	5	2	4	5
Number of storeys	2	4	5	2	4	5	2	4	5	2	4	5
Height, h_n (ft)	22.0	42.0	52.2	22.0	42.0	52.2	22.0	42.0	52.2	22.0	42.0	52.2
Number of braced walls	2	2	2	2	3	3	3	4	4	4	7	7
$T_a = 0.025h_n$ (s) ^a	0.168	0.32	0.398	0.168	0.32	0.398	0.168	0.32	0.398	0.168	0.32	0.398
$2 \times T_{ap}$ (s) ^b	0.335	0.64	0.795	0.335	0.64	0.795	0.335	0.64	0.795	0.335	0.64	0.795
Fundamental period, T (s)	0.85	1.39	1.69	0.74	1.17	1.39	0.53	0.85	1.03	0.41	0.56c	0.67c
$S(T_a)$	0.12	0.07	0.06	0.19	0.11	0.09	0.46	0.26	0.21	0.81	0.6	0.54
$S_d(0.2)$		0.15			0.23			0.59			0.94	
$S_d(0.5)$		0.084			0.13			0.3			0.64	
$S_d(1.0)$		0.041			0.069			0.14			0.33	
$S_d(2.0)$		0.023			0.019			0.048			0.17	
Seismic weight per floor, W_i (kips)	1 st	141.8	141.8	141.8	141.8	141.8	141.8	141.8	141.8	141.8	141.8	141.8
	2 nd	46.2	141.8	141.8	60.3	141.8	141.8	77.1	141.8	141.8	54.3	141.8
	3 rd	-	141.8	141.8	-	141.8	141.8	-	141.8	141.8	-	141.8
	4 th	-	46.2	141.8	-	60.3	141.8	-	77.1	141.8	-	54.3
	5 th	-	-	46.2	-	-	60.3	-	-	77.1	-	-
Seismic weight for the structure, W (kips)	188.0	471.5	613.3	202.0	485.6	627.4	218.8	502.4	644.2	196.1	479.7	621.4
Base shear, (kips) $V = \frac{S(T_a)M_s I_e W}{R_d R_o}$	13.9	20.3	22.6	23.6	32.9	34.7	61.9	80.4	83.2	97.8	177.1	206.5
Minimum base shear, (kips) $V_{min} = \frac{S(2.0)M_s I_e W}{R_d R_o}$	2.7	6.7	8.7	2.4	5.7	7.3	6.5	14.8	19.0	20.5	50.2	65.0
Maximum base shear, (kips) $V_{max} = \frac{2S(0.2)I_e W}{3 R_d R_o}$	11.6	29.0	37.7	19.1	45.8	59.2	53.0	121.6	155.9	75.6	185.0	239.6
Design base shear, (kips) $V_{min} \leq V \leq V_{max}$	11.6	20.3	22.6	19.1	32.9	34.7	53.0	80.4	83.2	75.6	177.1	206.5
$F_t = 0.07 T_a V$, $T_a \geq 0.7 s$ $F_t = 0$, $T_a < 0.7 s$, (kips)	0.0	0.0	1.3	0.0	0.0	1.9	0.0	0.0	4.6	0.0	0.0	0.0
Lateral force per storey, (kips) $F_x = \frac{(V - F_t)W_x h_x}{\sum_{i=1}^n W_i h_i}$	1 st	7.2	3.1	2.0	10.7	4.8	3.2	26.5	10.7	6.8	44.4	26.0
	2 nd	4.3	5.8	3.7	8.3	8.9	5.8	26.4	19.5	12.5	31.2	47.7
	3 rd	-	8.4	5.4	-	12.9	8.5	-	28.4	18.2	-	69.4
	4 th	-	3.6	7.1	-	7.2	11.1	-	20.3	24.0	-	34.9
	5 th	-	-	4.1	-	-	7.9	-	-	20.6	-	-
Foce due to torsion, (kips) $F_{tor} = 0.1F_x$	1 st	0.7	0.3	0.2	1.1	0.5	0.3	2.7	1.1	0.7	4.4	2.6
	2 nd	0.4	0.6	0.4	0.8	0.9	0.6	2.6	2.0	1.2	3.1	4.8
	3 rd	-	0.8	0.5	-	1.3	0.8	-	2.8	1.8	-	6.9
	4 th	-	0.4	0.7	-	0.7	1.1	-	2.0	2.4	-	3.5
	5 th	-	-	0.4	-	-	0.8	-	-	2.1	-	-
Shear force per storey, (kips)	1 st	13.9	26.0	28.5	22.2	40.2	44.2	59.6	90.0	94.2	84.4	199.0
	2 nd	5.0	21.6	25.3	9.5	34.0	39.7	29.5	77.3	85.8	34.6	169.4
	3 rd	-	14.3	20.3	-	23.3	32.4	-	54.9	71.1	-	116.0
	4 th	-	4.2	13.4	-	8.2	22.1	-	22.7	50.2	-	38.7
	5 th	-	-	4.7	-	-	8.9	-	-	23.0	-	-
Factored force per brace, (kips)	1 st	5.5	10.3	11.2	8.8	10.6	11.6	15.7	17.8	18.6	16.7	22.5
	2 nd	1.8	7.6	8.9	3.3	8.0	9.4	6.9	13.7	15.2	6.1	17.1
	3 rd	-	5.1	7.2	-	5.5	7.6	-	9.7	12.6	-	11.7
	4 th	-	1.5	4.7	-	1.9	5.2	-	4.0	8.9	-	3.9
	5 th	-	-	1.7	-	-	2.1	-	-	4.1	-	-

^a Clause 4.1.8.11. 3b NBCC, ^b Clause 4.1.8.11. 3d NBCC, ^c Braces designed for the fundamental period

3.3. DESIGN OF BRACES AND STOREY DEFLECTION

Once the factored seismic brace force was computed for each storey in the building the braces were designed according to the procedure described in Section 2.0. Brace size was rounded up to the nearest half inch (12.7mm). Also, based on previous tests and practical reasons brace width was selected in the range of 63.5mm (2.5”) to 228.6mm (9”), and the brace thickness was kept the same for the whole building to simplify the construction process. Brace thickness was chosen from the available cold-formed steel in the market: $t = 1.37\text{mm}$ and $t = 1.73\text{ mm}$ with $F_y = 340\text{ MPa}$ and $F_u = 450\text{ MPa}$. The braces used in the ground floors of the four and five storey buildings in Vancouver were of 190.5mm (7.5”) and 228.6mm (9”) width, respectively. This width is significantly over the maximum 152.4mm (6”) width that was used in test specimens but it was difficult to increase the number of braced bents in the building because of the many openings in the residential structure. All brace sizes are presented in Table 3.6.

Table 3.6 Selected brace sizes

City		Calgary, AB ^a			Halifax, NS ^a			Quebec, QC ^b			Vancouver, BC ^b			
Number of Storeys		2	4	5	2	4	5	2	4	5	2	4	5	
Number of braced walls		2	2	2	2	3	3	3	4	4	4	7	7	
Height, h_b		m	6.7	12.8	15.9	6.7	12.8	15.9	6.7	12.8	15.9	6.7	12.8	15.9
		ft	22.0	42.0	52.2	22.0	42.0	52.2	22.0	42.0	52.2	22.0	42.0	52.2
Selected Brace Width	1 st	mm	63.5	114.3	127.0	101.6	141.3	127.0	139.7	152.4	165.1	139.7	190.5	228.6
		in	2.5	4.5	5.0	4.0	5.6	5.0	5.5	6.0	6.5	5.5	7.5	9.0
	2 nd	mm	63.5	88.9	101.6	63.5	88.9	101.6	63.5	114.3	127.0	63.5	152.4	177.8
		in	2.5	3.5	4.0	2.5	3.5	4.0	2.5	4.5	5.0	2.5	6.0	7.0
	3 rd	mm	-	63.5	76.2	-	63.5	88.9	-	88.9	114.3	-	101.6	152.4
		in	-	2.5	3.0	-	2.5	3.5	-	3.5	4.5	-	4.0	6.0
	4 th	mm	-	63.5	63.5	-	63.5	63.5	-	63.5	76.2	-	63.5	101.6
		in	-	2.5	2.5	-	2.5	2.5	-	2.5	3.0	-	2.5	4.0
	5 th	mm	-	-	63.5	-	-	63.5	-	-	63.5	-	-	63.5
		in	-	-	2.5	-	-	2.5	-	-	2.5	-	-	2.5

^a brace thickness $t=1.37\text{mm}$ (0.054 in), $F_y=340\text{ MPa}$ (50 ksi); ^b brace thickness $t=1.73\text{mm}$ (0.068 in), $F_y=340\text{ MPa}$

In addition, the elastic horizontal deflection Δ_E of the brace bent was determined as:

$$\Delta_E = \frac{Vd^3}{EL^2A} \quad (3.10)$$

where V is the shear force per wall (the shear force per storey (Table 3.4) divided by the numbers of walls), d is the length of the straps, $E = 203000$ MPa, L is the length of the brace bent, and A is the gross cross-section area of the straps (Figure 3.6).

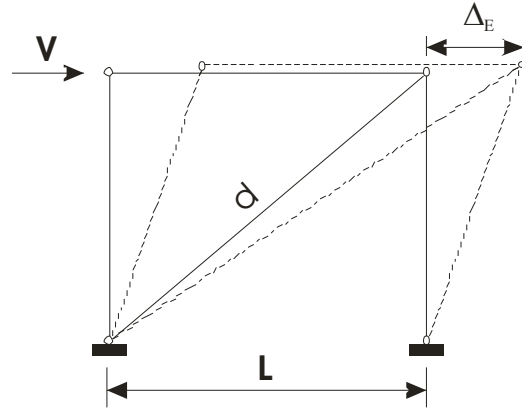

Figure 3.6 Shear deflection model

The inelastic storey deflection Δ_{mx} was calculated following the 2005 NBCC approach as:

$$\Delta_{mx} = \frac{R_d R_o}{I_E} \Delta_E \quad (3.11)$$

The P- Δ effects were also taken into account following the 2005 NBCC Structural Commentary J (NRCC, 2005) sentence 4.1.8.3 (8):

$$\theta_x = \frac{\sum_{i=x}^n W_i}{R_o \sum_{i=x}^n F_i} \frac{\Delta_{mx}}{h_s} \quad (3.12)$$

where θ_x is the stability factor at level x , W_i is the portion of the factored dead plus live load above the storey under consideration, h_s is the interstorey height, and F_i is the shear force at level x . When W_i was calculated a live load reduction factor (LLRF) (2005 NBCC cl. 4.1.5.9) was used:

$$LLRF = 0.3 + \sqrt{9.8/B} \quad (3.13)$$

where B is the tributary area in square metres. As can be seen from Table 3.7 the stability factor θ_x is less than 0.10, in this case the $P-\Delta$ effects can be ignored and they were not considered in the design. Also, the interstorey drift (Table 3.7) does not exceed the drift limit of 2.5 % listed in the NBCC 2005. Note, for the design of conventional construction braced walls a maximum drift limit of 1 % based on the test data of relevant strap braced walls (*Al-Kharat and Rogers, 2007, 2008*) was applied.

Table 3.7 Interstorey drift

City		Calgary, AB			Halifax, NS			Quebec, QC			Vancouver, BC		
Number of Storeys		2	4	5	2	4	5	2	4	5	2	4	5
Height, h_n (m)		6.7	12.8	15.9	6.7	12.8	15.9	6.7	12.8	15.9	6.7	12.8	15.9
Number of braced walls		2	2	2	2	3	3	3	4	4	4	7	7
\square_E , mm	1 st	9.4	9.8	9.7	9.4	10.2	10.0	9.7	10.1	9.8	10.3	10.2	9.8
	2 nd	2.5	7.5	7.7	4.6	7.9	8.1	7.6	8.3	8.3	6.7	7.8	8.2
	3 rd	-	7.0	8.2	-	7.6	7.5	-	7.6	7.6	-	8.0	7.8
	4 th	-	2.0	6.5	-	2.6	7.2	-	4.4	8.1	-	4.3	7.6
	5 th	-	-	2.3	-	-	2.9	-	-	4.5	-	-	3.9
\square_{mx} , mm	1 st	15.3	16.0	15.7	15.3	16.5	16.3	15.8	16.4	15.9	16.8	16.6	15.9
	2 nd	4.0	12.2	12.5	7.5	12.8	13.1	12.4	13.5	13.5	10.9	12.7	13.3
	3 rd	-	11.4	13.4	-	12.3	12.2	-	12.3	12.4	-	13.0	12.6
	4 th	-	3.3	10.6	-	4.3	11.7	-	7.1	13.2	-	7.0	12.4
	5 th	-	-	3.7	-	-	4.7	-	-	7.3	-	-	6.4
interstorey drift, %	1 st	0.46	0.48	0.47	0.46	0.49	0.48	0.47	0.49	0.47	0.50	0.50	0.48
	2 nd	0.14	0.45	0.46	0.27	0.47	0.48	0.45	0.49	0.49	0.40	0.46	0.49
	3 rd	-	0.41	0.49	-	0.45	0.45	-	0.45	0.45	-	0.48	0.46
	4 th	-	0.12	0.39	-	0.16	0.43	-	0.26	0.48	-	0.25	0.45
	5 th	-	-	0.14	-	-	0.17	-	-	0.26	-	-	0.23
W_p , kN	1 st	961	2393	3103	1024	2480	3194	1112	2575	3292	1023	2524	3248
	2 nd	205	1664	2379	268	1743	2462	343	1831	2555	242	1763	2496
	3 rd	-	935	1654	-	1005	1731	-	1087	1817	-	1002	1745
	4 th	-	205	930	-	268	1000	-	343	1080	-	242	993
	5 th	-	-	205	-	-	268	-	-	343	-	-	242
\square_x	1 st	0.050	0.069	0.081	0.033	0.048	0.056	0.014	0.022	0.026	0.010	0.010	0.011
	2 nd	0.009	0.053	0.067	0.012	0.037	0.046	0.008	0.018	0.023	0.004	0.007	0.009
	3 rd	-	0.420	0.062	-	0.03	0.037	-	0.014	0.018	-	0.006	0.007
	4 th	-	0.009	0.042	-	0.008	0.030	-	0.006	0.016	-	0.002	0.006
	5 th	-	-	0.009	-	-	0.008	-	-	0.060	-	-	0.002

Table 3.8 Interstorey drift (US customary units)

City	Calgary, AB			Halifax, NS			Quebec, QC			Vancouver, BC			
Number of Storeys	2	4	5	2	4	5	2	4	5	2	4	5	
Height, h_n (ft)	22.0	42.0	52.2	22.0	42.0	52.2	22.0	42.0	52.2	22.0	42.0	52.2	
Number of braced walls	2	2	2	2	3	3	3	4	4	4	7	7	
Δ_E , in	1 st	0.37	0.39	0.38	0.37	0.40	0.39	0.38	0.40	0.39	0.41	0.40	0.39
	2 nd	0.10	0.30	0.30	0.18	0.31	0.32	0.30	0.33	0.33	0.26	0.31	0.32
	3 rd	-	0.28	0.32	-	0.30	0.30	-	0.30	0.30	-	0.31	0.31
	4 th	-	0.08	0.26	-	0.10	0.28	-	0.17	0.32	-	0.17	0.30
	5 th	-	-	0.09	-	-	0.11	-	-	0.18	-	-	0.16
Δ_{mx} , in	1 st	0.60	0.63	0.62	0.60	0.65	0.64	0.62	0.65	0.63	0.66	0.65	0.63
	2 nd	0.16	0.48	0.49	0.30	0.50	0.52	0.49	0.53	0.53	0.43	0.50	0.52
	3 rd	-	0.45	0.53	-	0.48	0.48	-	0.48	0.49	-	0.51	0.50
	4 th	-	0.13	0.42	-	0.17	0.46	-	0.28	0.52	-	0.28	0.49
	5 th	-	-	0.15	-	-	0.19	-	-	0.29	-	-	0.25
interstorey drift, %	1 st	0.46	0.48	0.47	0.46	0.49	0.48	0.47	0.49	0.47	0.50	0.50	0.48
	2 nd	0.14	0.45	0.46	0.27	0.47	0.48	0.45	0.49	0.49	0.40	0.46	0.49
	3 rd	-	0.41	0.49	-	0.45	0.45	-	0.45	0.45	-	0.48	0.46
	4 th	-	0.12	0.39	-	0.16	0.43	-	0.26	0.48	-	0.25	0.45
	5 th	-	-	0.14	-	-	0.17	-	-	0.26	-	-	0.23
W_p , kips	1 st	216	538	698	230	558	718	250	579	740	230	567	730
	2 nd	46	374	535	60	392	554	77	412	574	54	396	561
	3 rd	-	210	372	-	226	389	-	244	408	-	225	392
	4 th	-	46	209	-	60	225	-	77	243	-	54	223
	5 th	-	-	46	-	-	60	-	-	77	-	-	54
Δ_x	1 st	0.050	0.069	0.081	0.033	0.048	0.056	0.014	0.022	0.026	0.010	0.010	0.011
	2 nd	0.009	0.053	0.067	0.012	0.037	0.046	0.008	0.018	0.023	0.004	0.007	0.009
	3 rd	-	0.420	0.062	-	0.03	0.037	-	0.014	0.018	-	0.006	0.007
	4 th	-	0.009	0.042	-	0.008	0.030	-	0.006	0.016	-	0.002	0.006
	5 th	-	-	0.009	-	-	0.008	-	-	0.060	-	-	0.002

3.4. NONLINEAR DYNAMIC ANALYSIS

3.4.1. Earthquake Records

The ATC 63 has a set of 44 recommended ground motion records that are predominately for the seismic hazard in the west US. Since three of the four sites are located in quite different zones, in which earthquakes originate by different mechanisms it was thought appropriate to select records that were representative of the local seismic hazard. Due to the limited number of recorded ground motions available, especially for eastern Canada, a database of synthetic records was relied on. These synthetic records were developed by Atkinson (2008) who used the stochastic finite-fault method to generate UHS-compatible earthquake time histories. Forty five earthquake records were used for the non-linear

dynamic analyses of the buildings in each city. For Calgary, Halifax and Quebec 44 synthetic records were selected from a database of ground motions for eastern North America, site class C, that are compatible with the 2005 NBCC uniform hazard spectrum (UHS) (Atkinson, 2008). Half of them were chosen from the simulated motions with magnitude M6 and the rest were with magnitude M7.5 as recommended by Atkinson (2008). For Vancouver only 32 synthetic records for the Pacific coast of North America site class “C” were selected: half of them with magnitude M6.5 and the rest were with magnitude M7.5; as well, twelve real earthquake records were used in the analyses. The latter were taken from the ATC-63 earthquake listing at locations having site class C soil conditions. All earthquake records were initially scaled to match the UHS of the 2005 NBCC for site class “C” and importance factor $I_E = 1$. The scaling factor was chosen in such a way that the scaled earthquake record matched as closely as possible the UHS especially in the range between the first and second period of vibration of the model. Also, for each of the selected cities one spectrum matched (SM) earthquake was generated using the program Spectre developed at École Polytechnique de Montréal (Léger et al., 1993). This program uses the Fast Fourier Transform (FFT) to obtain the response spectrum of the spectrum matched earthquake at each frequency. After that these amplitudes are multiplied by the ratio of the Fourier coefficient of the desired response spectrum (in our case the 2005 NBCC UHS) and the amplitudes of the response spectrum of the initial earthquake. The process is iterative; ten iterations were applied to obtain the spectrum (closely) matched earthquake record. The scaling factor and the number of the record from the electronic file developed by Atkinson (2008) are given in Table 3.9 and Table 3.10. The response spectra of the scaled earthquake time histories are shown in Figure 3.7 to Figure 3.11, and in order to demonstrate that the earthquakes were properly scaled the mean scaled spectra is compared to the design UHS in Figure 3.12.

Table 3.9 Summary of ground motions for Calgary, Halifax and Quebec site class “C”

No. ^a	Record Number	Magn.	PGA (g)	Epicentral Distance (km)	Scaling Factor, SF			Time Step (s)
					Calgary	Halifax	Quebec	
1	3	M6.0	0.19	18.8	0.50	0.75	1.80	0.005
2	11		0.37	18.8	0.25	0.40	1.00	0.005
3	12		0.14	21.9	0.50	0.75	1.80	0.005
4	17		0.03	52.6	2.50	3.75	9.30	0.005
5	29		0.08	17.5	1.00	1.50	3.60	0.005
6	40		0.05	23.2	1.60	2.40	6.00	0.005
7	42		0.07	31.1	1.10	1.65	4.00	0.005
8	46		0.39	16.3	0.25	0.40	1.00	0.005
9	47		0.27	17.5	0.40	0.60	1.50	0.005
10	52		0.02	38.1	2.85	4.30	9.00	0.005
11	56		0.12	18.8	0.60	0.90	2.00	0.005
12	67		0.07	22.9	1.35	2.00	4.80	0.005
13	72		0.02	95.1	4.25	6.40	13.50	0.005
14	89		0.05	52.3	2.25	3.40	7.50	0.005
15	99		0.06	99.4	1.20	1.80	4.00	0.005
16	107		0.05	51.0	1.60	2.40	6.00	0.005
17	117		0.04	100.0	1.85	2.80	6.00	0.005
18	147		0.18	14.2	0.50	0.75	1.70	0.005
19	153		0.02	97.8	3.50	5.20	12.00	0.005
20	162		0.02	100.4	3.25	4.80	12.00	0.005
21	163		0.47	7.3	0.25	0.40	0.80	0.005
22	180		0.02	98.6	3.60	5.20	12.00	0.005
23	225	M7.0	0.09	85.0	0.80	1.20	2.80	0.005
24	230		0.41	27.1	0.25	0.40	0.90	0.005
25	231		0.21	31.8	0.35	0.50	1.20	0.005
26	233		0.27	51.2	0.25	0.40	1.00	0.005
27	234		0.07	100.7	0.95	1.40	3.40	0.005
28	240		0.30	17.7	0.35	0.50	1.10	0.005
29	241		0.27	26.5	0.45	0.65	1.50	0.005
30	242		0.34	35.9	0.35	0.50	1.00	0.005
31	243		0.07	85.1	1.00	1.50	3.50	0.005
32	252		0.12	90.4	0.60	0.90	2.20	0.005
33	269		0.21	38.4	0.35	0.55	1.20	0.005
34	270		0.11	85.8	0.65	0.95	2.20	0.005
35	295		0.23	30.6	0.45	0.65	1.40	0.005
36	305		0.11	52.9	0.75	1.10	2.50	0.005
37	322		0.19	35.8	0.40	0.60	1.40	0.005
38	349		0.17	38.4	0.35	0.50	1.20	0.005
39	360		0.08	87.4	0.60	0.90	2.20	0.005
40	368		0.09	38.8	0.65	1.00	2.20	0.005
41	377		0.14	51.7	0.55	0.80	1.80	0.005
42	386		0.35	38.8	0.25	0.35	0.80	0.005
43	393		0.15	26.0	0.55	0.80	1.90	0.005
44	395		0.11	43.6	0.60	0.90	2.00	0.005
45	SM	-	-	-	1.00	1.00	1.00	0.010

^aRecords 1 to 44 are synthetic earthquake time histories from Atkinson (2008)

Table3.10 Summary of ground motions for Vancouver site class “C”

No. ^{a, b}	Record Number	Magn.	Station	Deg.	PGA (g)	Epicentral Distance (km)	Scaling Factor, SF	Time Step (s)
1	7	M6.0	-	-	0.19	27.2	3.00	0.005
2	17		-	-	0.06	50.1	4.00	0.005
3	25		-	-	0.13	27.2	3.00	0.005
4	29		-	-	0.18	7.1	1.80	0.005
5	30		-	-	0.20	10.7	1.80	0.005
6	82		-	-	0.34	5.0	1.10	0.005
7	100		-	-	0.41	3.5	1.30	0.005
8	109		-	-	0.47	3.5	0.90	0.005
9	148		-	-	0.29	5.5	1.10	0.005
10	156		-	-	0.35	15.0	1.00	0.005
11	161		-	-	0.38	50.1	0.70	0.005
12	170		-	-	0.15	35.6	2.00	0.005
13	179		-	-	0.17	41.2	2.00	0.005
14	186		-	-	0.24	22.3	1.50	0.005
15	188		-	-	0.17	41.1	1.80	0.005
16	197		-	-	0.23	40.8	1.20	0.005
17	237	M7.5	-	-	0.78	1.0	0.50	0.005
18	268		-	-	0.26	28.2	1.30	0.005
19	305		-	-	0.28	50.1	1.30	0.005
20	311		-	-	0.92	1.0	0.60	0.005
21	317		-	-	1.53	7.1	0.60	0.005
22	321		-	-	0.39	21.3	1.25	0.005
23	326		-	-	2.62	7.1	0.25	0.005
24	328		-	-	0.52	14.2	0.80	0.005
25	344		-	-	1.04	9.7	0.50	0.005
26	355		-	-	1.19	13.8	0.50	0.005
27	363		-	-	1.32	1.0	0.40	0.005
28	389		-	-	0.26	7.2	1.10	0.005
29	408		-	-	0.64	8.2	0.60	0.005
30	410		-	-	0.34	13.7	0.90	0.005
31	411		-	-	0.36	16.5	0.90	0.005
32	430		-	-	0.13	21.9	2.40	0.005
33	CHICHIE	M7.6	TCU045	90	0.49	77.5	1.10	0.005
34	CHICHIN			0			1.00	0.005
35	FRULI000	M6.5	Tolmezzo	0	0.33	20.2	1.50	0.005
36	FRULI270			270			1.00	0.005
37	HECTOR000	M7.1	Hector	0	0.30	26.5	2.00	0.005
38	HECTOR090			90			1.40	0.005
39	KOBE000	M6.9	Nishi-Akashi	0	0.51	8.7	0.80	0.010
40	KOBE090			90			1.00	0.010
41	KOCAELI000	M7.5	Arcelik	0	0.18	53.7	3.00	0.005
42	KOCAELI090			90			2.80	0.005
43	MANJILL	M7.4	Abbar	-	0.51	40.4	0.90	0.020
44	MANJILT			-			0.75	0.020
45	SM	-	-	-	-	-	-	0.010

^aRecords 1 to 44 are synthetic time histories from Atkinson (2008)

^bRecords 33 to 44 are time histories from PEER NGA database (PEER, 2005) (ATC-63, 2008)

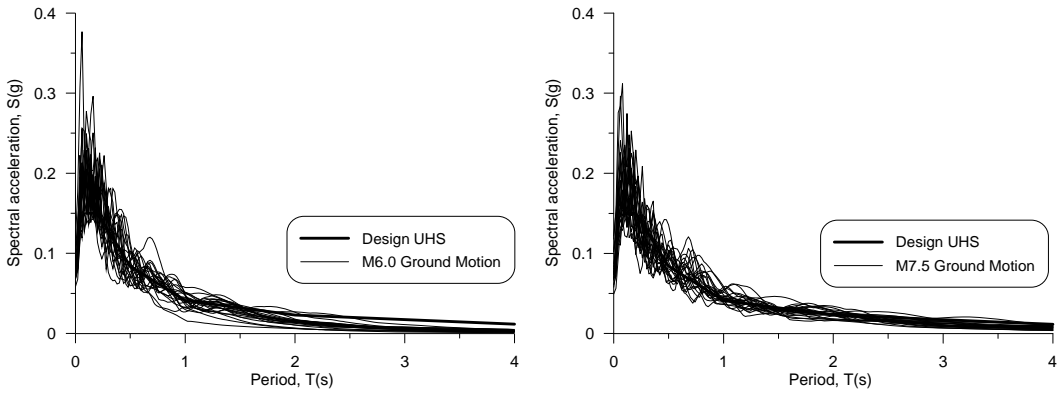

Figure 3.7 Ground motions scaled to 2005 NBCC UHS for Calgary

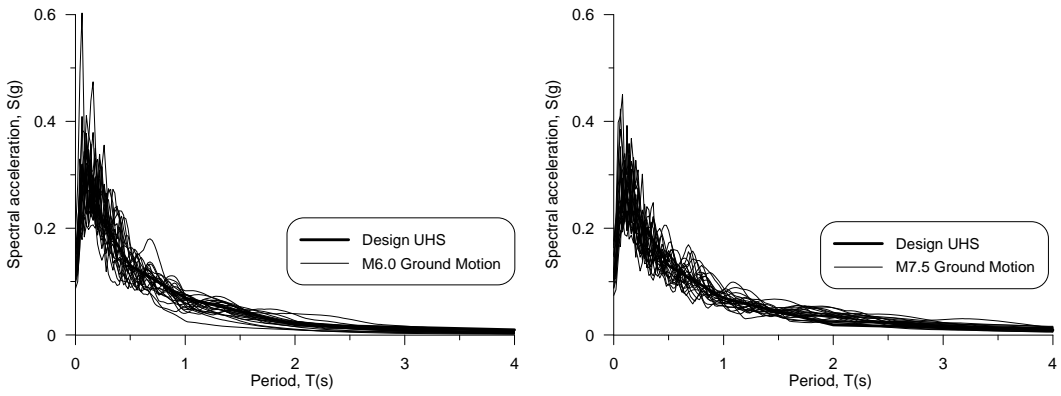

Figure 3.8 Ground motions scaled to 2005 NBCC UHS for Halifax

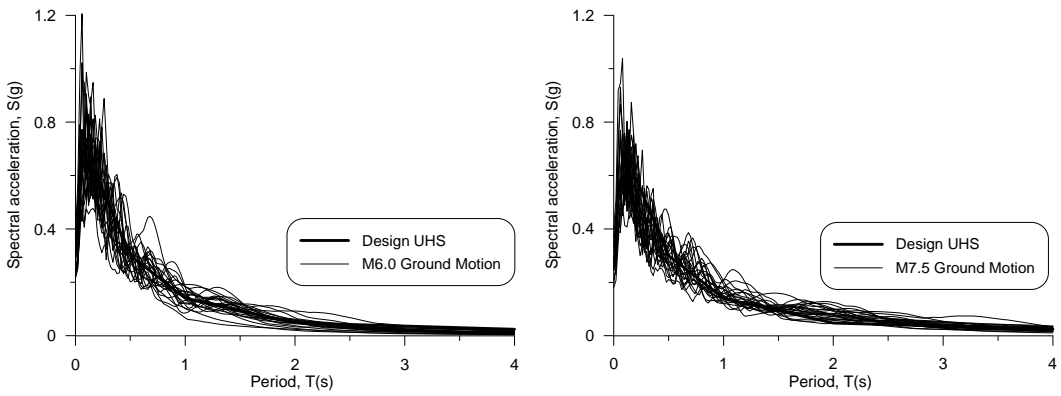

Figure 3.9 Ground motions scaled to 2005 NBCC UHS for Quebec

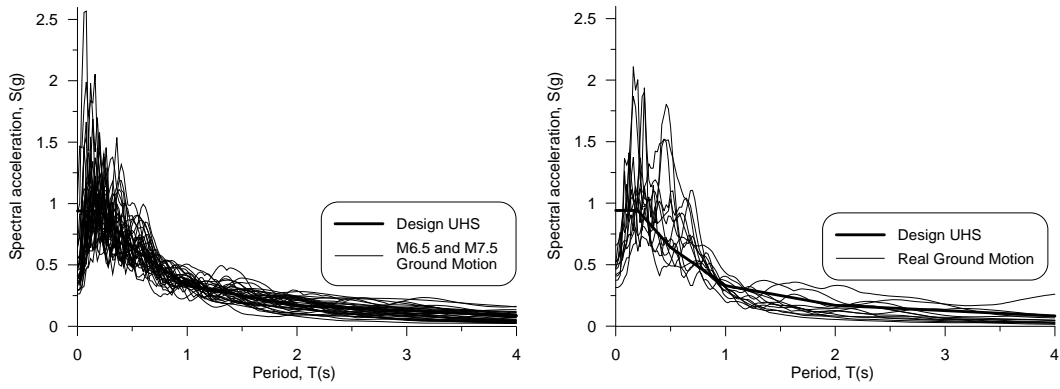

Figure 3.10 Ground motions scaled to 2005 NBCC UHS for Vancouver

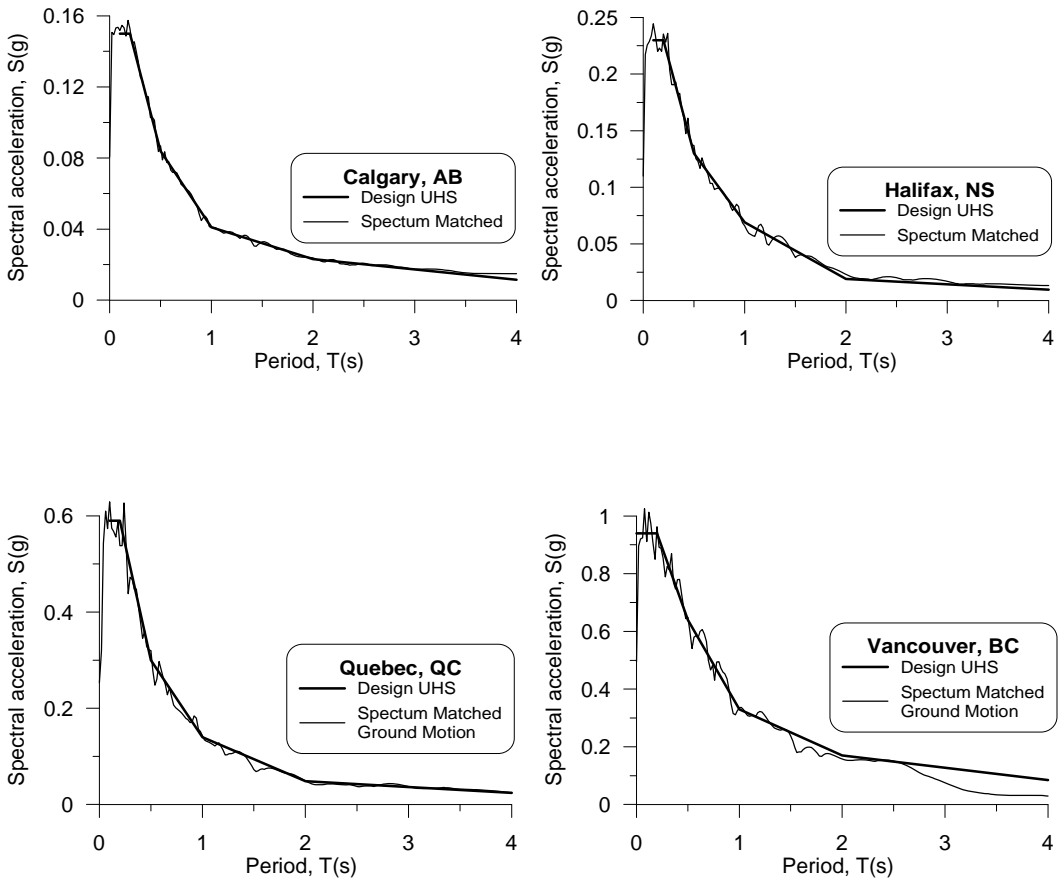

Figure 3.11 Spectrum matched ground motions

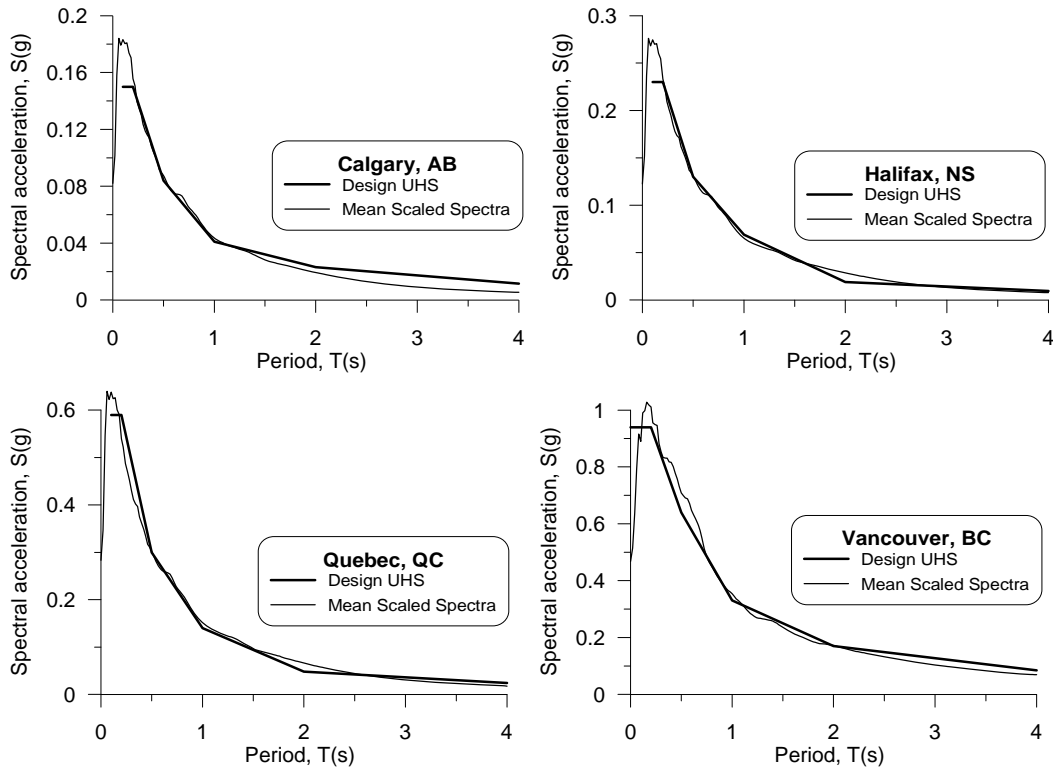

Figure 3.12 Mean scaled earthquake spectra compared to design UHS

3.4.2. Hysteretic Behaviour of Walls

There are many different hysteresis rules that represent the inelastic behaviour of an element incorporated in RUAUMOKO. It was necessary to select and calibrate a hysteretic rule that has similar load versus deflection behaviour to the test specimens described in Chapter 2. A bi-linear spring element with strain hardening and slackness characteristics was chosen based on the fact that it was developed to represent diagonal braced systems and it accounts for the pinching and strain hardening that were observed during testing (Figure 3.13). Furthermore, the bi-linear with slackness model matches very well the results from cyclic testing as shown in Figure 3.14. Note, these walls exhibited excellent ductility unlike that observed for test specimens for which a capacity design approach was not implemented. The one drawback to using this element is that it does not provide for strength degradation; hence a maximum drift limit must be identified based on relevant strap braced wall test data (*Al-Kharat and Rogers, 2007, 2008*)

where the wall specimens were not detailed following a capacity based design approach and most of the specimens failed at drift levels approaching 1.0%.

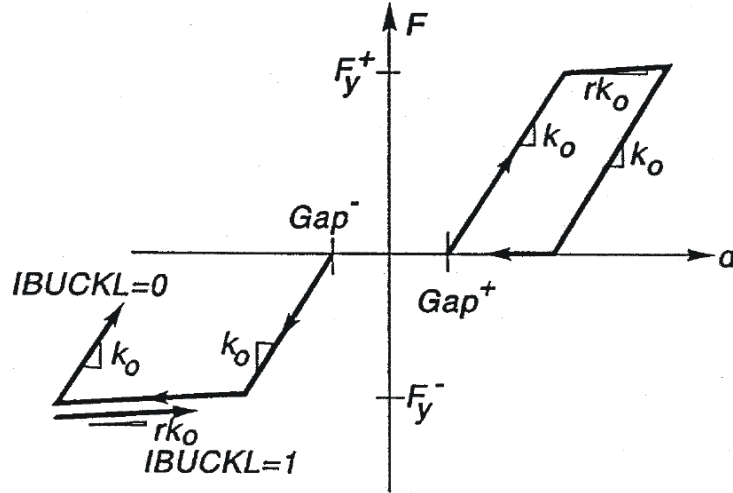

Figure 3.13 Bi-linear with Slackness Hysteresis (Carr, 2000)

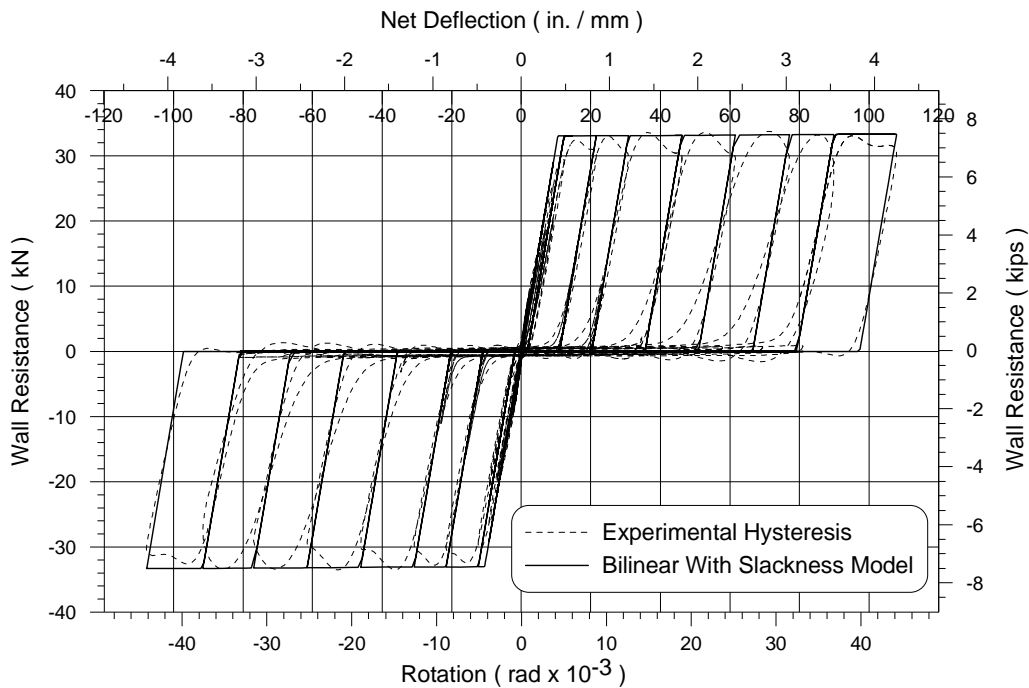

Figure 3.14 Superposition of bilinear with slackness model and experimental cyclic test 42A-C

The wall resistance versus displacement diagram was generated from the program HYSTERES that is included with RUAUMOKO. As an input the displacements

from a cyclic test were used and the program generated the resistance versus displacement diagrams that are presented in Figure 3.14. Ten parameters are required to accurately replicate the cyclic experimental hysteresis of a test specimen using the bi-linear with slackness model. Values for the stiffness K_o , yield force $F_y^{RUAUMOKO}$ and bi-linear factor r were obtained from the test data and visual inspection and comparison of experimental load versus deflection curves and the Bi-linear with Slackness Hysteresis. The calculated elastic stiffness of the model includes the combined effect of the braces, brace connections, holddowns and anchor rods. Based on the test results it was found that the measured elastic slope was approximately 80% of the calculated values; for this reason the model stiffness incorporated the calculated value with a reduction of 20%. The post yield slope rK_o (Figure 3.13) in the hysteresis model is defined as a fraction of the elastic slope K_o and it takes into account the strain hardening that was observed during testing. Therefore the bi-linear factor r was computed as the ratio of corrected stiffness K_o and the average post yield slope obtained from the test results of the medium and heavy test walls. It was assumed that there is no initial slackness in braces, so the GAP+ and GAP – parameters were set to zero. Finally, the yield force parameter $F_y^{RUAUMOKO}$ was calculated as:

$$F_y^{RUAUMOKO} = 2A_b F_y R_y \cos \alpha \quad (3.14)$$

where A_b is the cross-section area of one strap, F_y is the nominal yield stress, $R_y = 1.1$ for 50 ksi (340 MPa) ASTM A653 steels (*AISI S213-07*), and α is the angle of straps with respect to horizontal. The main input parameters for the selected spring element (K_o , $F_y^{RUAUMOKO}$ and r) for each model, are given in Table 3.11. The remaining parameters were selected according to the RUAUMOKO manual.

Table 3.11 Model design summary

Model Name	Storey	Design parameters ^a						Modeling parameters ^b				
		ΣV_{fx} (kN)	t (mm)	b (mm)	b _{design} (in)	Δ_{mx} (mm)	k (kN/mm)	k _o (kN/mm)	F _y ^{Ruaumoko} (kN)	r		
Calgary	2 storey	2	22.2	1.37	18.7	2.5	4.0	3.93	3.14	46.07	0.0197	
		1	61.8		58.2	2.5	15.3	3.04	2.43	41.25	0.0255	
	4 storey	4	18.6	1.37	15.6	2.5	3.3	3.93	3.14	46.07	0.0197	
		3	63.8		53.7	2.5	11.4	3.93	3.14	46.07	0.0197	
		2	96.2		81.0	3.5	12.2	5.21	4.17	64.49	0.0149	
		1	115.8		108.9	4.5	16.0	5.17	4.14	74.26	0.0150	
	5 storey	5	21.0	1.37	17.7	2.5	3.7	3.93	3.14	46.07	0.0197	
		4	59.7		50.3	2.5	10.6	3.93	3.14	46.07	0.0197	
		3	90.2		76.0	3.0	13.4	4.58	3.67	55.28	0.0169	
		2	112.5		94.8	4.0	12.5	5.80	4.64	73.71	0.0133	
		1	126.6		119.0	5.0	15.7	5.67	4.54	82.51	0.0136	
	Halifax	2 storey	2	42.2	1.37	35.5	2.5	7.5	3.93	3.14	46.07	0.0197
			1	98.8		93.0	4.0	15.3	4.66	3.73	66.01	0.0166
		4 storey	4	36.5	1.37	20.5	2.5	4.3	3.93	3.14	46.07	0.0197
			3	103.7		58.2	2.5	12.3	3.93	3.14	46.07	0.0197
2			151.2	84.9		3.5	12.8	5.21	4.17	64.49	0.0149	
1			179.0	112.3		4.5	16.5	5.17	4.14	74.26	0.0150	
5 storey		5	39.8	1.37	22.4	2.5	4.7	3.93	3.14	46.07	0.0197	
		4	98.4		55.3	2.5	11.7	3.93	3.14	46.07	0.0197	
		3	144.0		80.9	3.5	12.2	5.21	4.17	64.49	0.0149	
		2	176.7		99.2	4.0	13.1	5.80	4.64	73.71	0.0133	
		1	196.4		123.2	5.0	16.3	5.67	4.54	82.51	0.0136	
Quebec		2 storey	2	131.1	1.73	58.5	2.5	12.4	4.77	3.82	58.01	0.0162
			1	265.1		132.0	5.5	15.8	7.47	5.97	114.29	0.0104
		4 storey	4	100.9	1.73	33.8	2.5	7.1	4.77	3.82	58.01	0.0162
			3	244.2		81.7	3.5	12.3	6.26	5.01	81.21	0.0124
	2		344.0	115.1		4.5	13.5	7.57	6.06	104.42	0.0102	
	1		400.3	149.5		6.0	16.4	8.02	6.41	124.68	0.0096	
	5 storey	5	102.4	1.73	34.3	2.5	7.3	4.77	3.82	58.01	0.0162	
		4	223.3		74.7	3.0	13.2	5.54	4.43	69.61	0.0140	
		3	316.3		105.8	4.5	12.4	7.57	6.06	104.42	0.0102	
		2	381.6		127.6	5.0	13.5	8.17	6.54	116.02	0.0095	
		1	419.1		156.5	6.5	15.9	8.55	6.84	135.07	0.0090	
	Vancouver	2 storey	2	153.9	1.73	51.5	2.5	10.9	4.77	3.82	58.01	0.0162
			1	375.5		140.2	5.5	16.8	7.47	5.97	114.29	0.0104
		4 storey	4	172.1	1.73	32.9	2.5	7.0	4.77	3.82	58.01	0.0162
			3	516.0		98.6	4.0	13.0	6.94	5.55	92.82	0.0112
2			753.7	144.1		6.0	12.7	9.27	7.42	139.22	0.0083	
1			885.3	188.9		7.5	16.6	9.57	7.66	155.85	0.0081	
5 storey		5	157.2	1.73	30.1	2.5	6.4	4.77	3.82	58.01	0.0162	
		4	490.2		93.7	4.0	12.4	6.94	5.55	92.82	0.0112	
		3	744.9		142.4	6.0	12.6	9.27	7.42	139.22	0.0083	
		2	921.4		176.1	7.0	13.3	10.25	8.20	162.43	0.0075	
		1	1019.5		217.6	9.0	15.9	10.99	8.79	187.02	0.0070	

^aDesign parameters (further explanation available in Section 3.4.2): ΣV_{fx} = cumulative design storey shear, t = brace thickness, b = initial brace width, b_{design} = rounded design brace width, Δ_{mx} = inelastic inter-storey deflection, k = design brace stiffness

^bModeling parameters (further explanation available in Section 3.2): k_o = model brace stiffness, F_y^{Ruaumoko} = capacity design yield load, r = post yield slope factor

3.4.3. RUAUMOKO model of the selected buildings

One braced bent of each building was modeled as an equivalent cantilever with a fictitious column carrying gravity loads in RUAUMOKO (Figure 3.15).

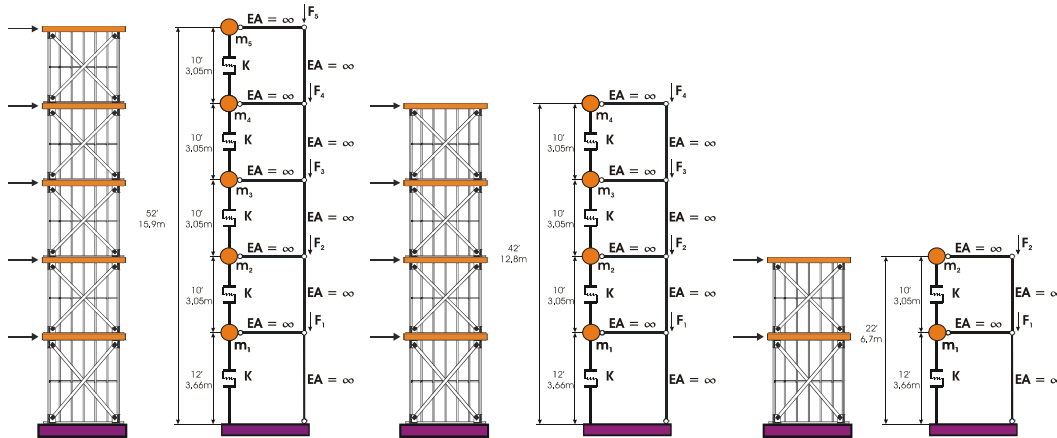

Figure 3.15 Braced bents and corresponding equivalent column models

Every section of the equivalent cantilever was modeled as an inelastic spring member representing a real braced storey. Each spring member was given the properties of the calibrated elements as described in Section 3.4.2. The model considers only shear deformations that are result of the elongation of braces and ignores the flexural displacements caused by the axial shortening and lengthening of the columns (chord studs). The total gravity load at each floor was applied to the corresponding level of the column. The seismic weight was lumped at each floor level; its values was determined by equally dividing the building seismic weight among all the bents because floors were considered to act as rigid diaphragms and the brace bents were of equal stiffness. The $P-\Delta$ effects were taken into account using a fictitious column. It was modeled as an axially rigid element with a flexural stiffness equivalent to zero connected to the equivalent cantilever by axially rigid links. A Rayleigh damping of 5% was assumed for the 1st and 2nd mode of vibration of the structure. One example input file for RUAMOUKO is given in the Appendix D, and the calculated and estimated periods of vibrations for all models are listed in Table 3.12.

Table 3.12 Periods of Vibration for Building Models

City	Calgary, AB			Halifax, NS			Quebec, QC			Vancouver, BC			
Number of Storeys	2	4	5	2	4	5	2	4	5	2	4	5	
Height, h_n	m	6.7	12.8	15.9	6.7	12.8	15.9	6.7	12.8	15.9	6.7	12.8	15.9
	ft	22.0	42.0	52.2	22.0	42.0	52.2	22.0	42.0	52.2	22.0	42.0	52.2
Number of braced walls	2	2	2	2	3	3	3	4	4	4	7	7	
$T_a = 0.025h_n$ (s) ^a	0.17	0.32	0.40	0.17	0.32	0.40	0.17	0.32	0.40	0.17	0.32	0.40	
$2 \times T_a$ (s) ^b	0.34	0.64	0.80	0.34	0.64	0.80	0.34	0.64	0.80	0.34	0.64	0.80	
Fundamental period, T (s)	0.85	1.39	1.69	0.74	1.17	1.39	0.53	0.85	1.03	0.41	0.56 ^c	0.67 ^c	

^a Clause 4.1.8.11. 3b NBCC, ^b Clause 4.1.8.11. 3d NBCC, ^c Braces designed for the fundamental period

Comeau (2008) carried out a comparison of a brace model that could account for the flexural displacement of the braced tower with the shear model (Figure 3.16). He was able to show that the shear model, even though of simple configuration compared with the brace model, could provide conservative results in terms of predicted storey deformations.

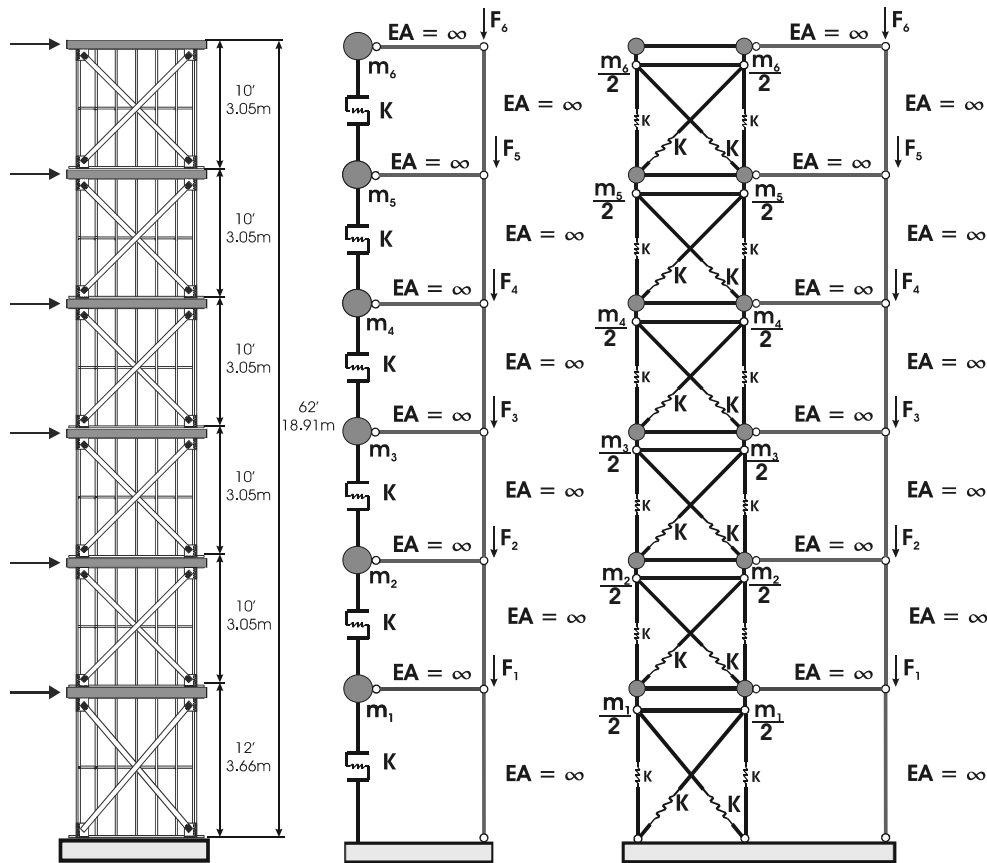

Figure 3.16 Shear versus brace model (Comeau 2008)

3.4.4. Storey drift analysis

The results of the preliminary dynamic analyses are presented in this section. Each of the building models was subjected to the 45 UHS scaled earthquake records (Section 3.3.1). The maximum storey drifts are shown in. Figure 3.17 to Figure 3.19

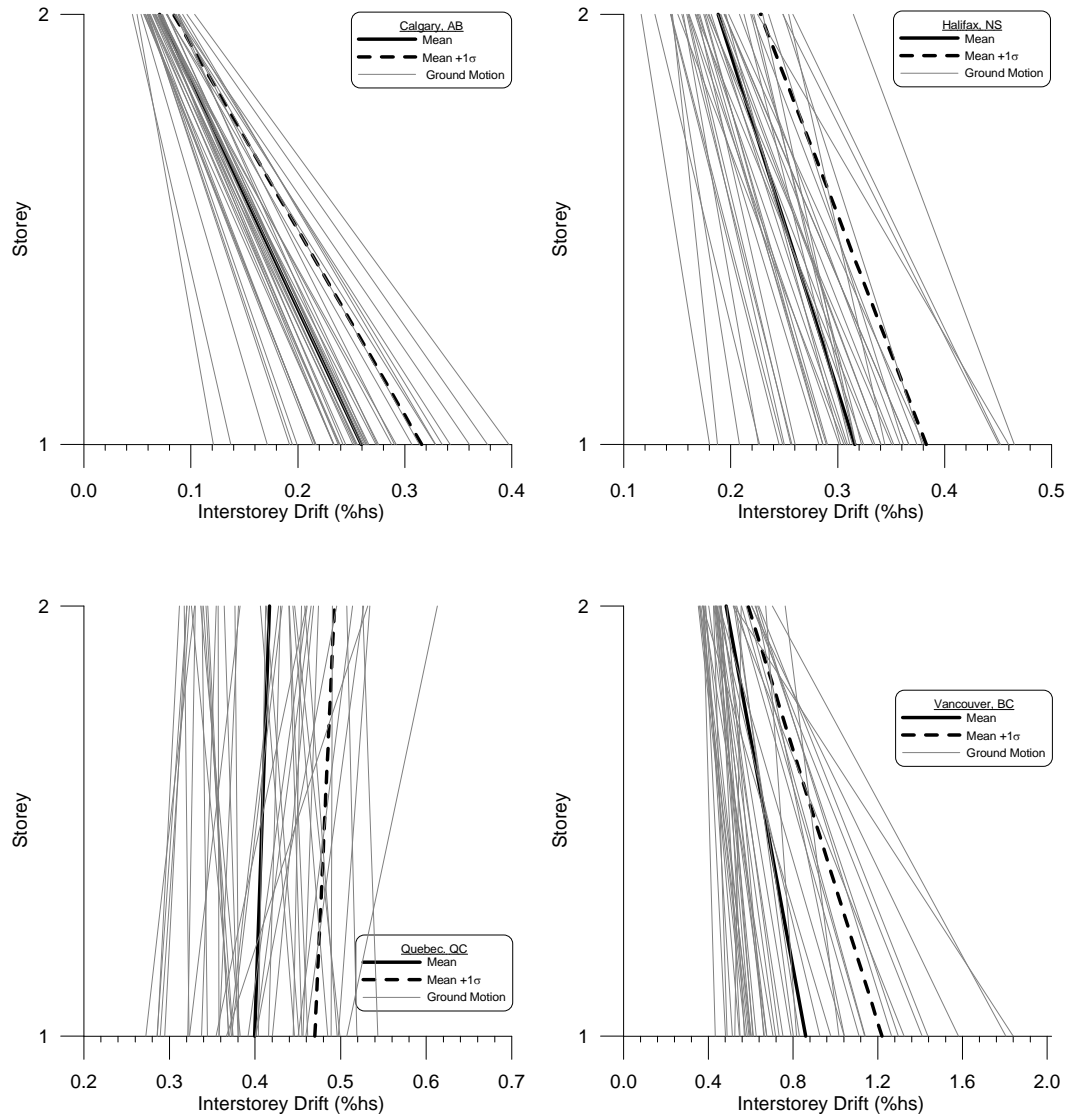

Figure 3.17 Storey drift of two-storey buildings under UHS scaled earthquake records

The graphs illustrate that for Calgary, Halifax and Quebec for all considered building configurations the maximum storey drift is 0.40 % ,0.47 % , and 0.82%

respectively; which is less than the maximum drift limit of 1% based on the behaviour of the conventional construction braced frames tested in the laboratory by Al-Kharat and Rogers (2007, 2008). However, for Vancouver the maximum storey drift is 2.22 %. A summary of the mean and mean + 1 standard deviation storey drifts calculated using all 45 ground motion records is given in Table 3.13.

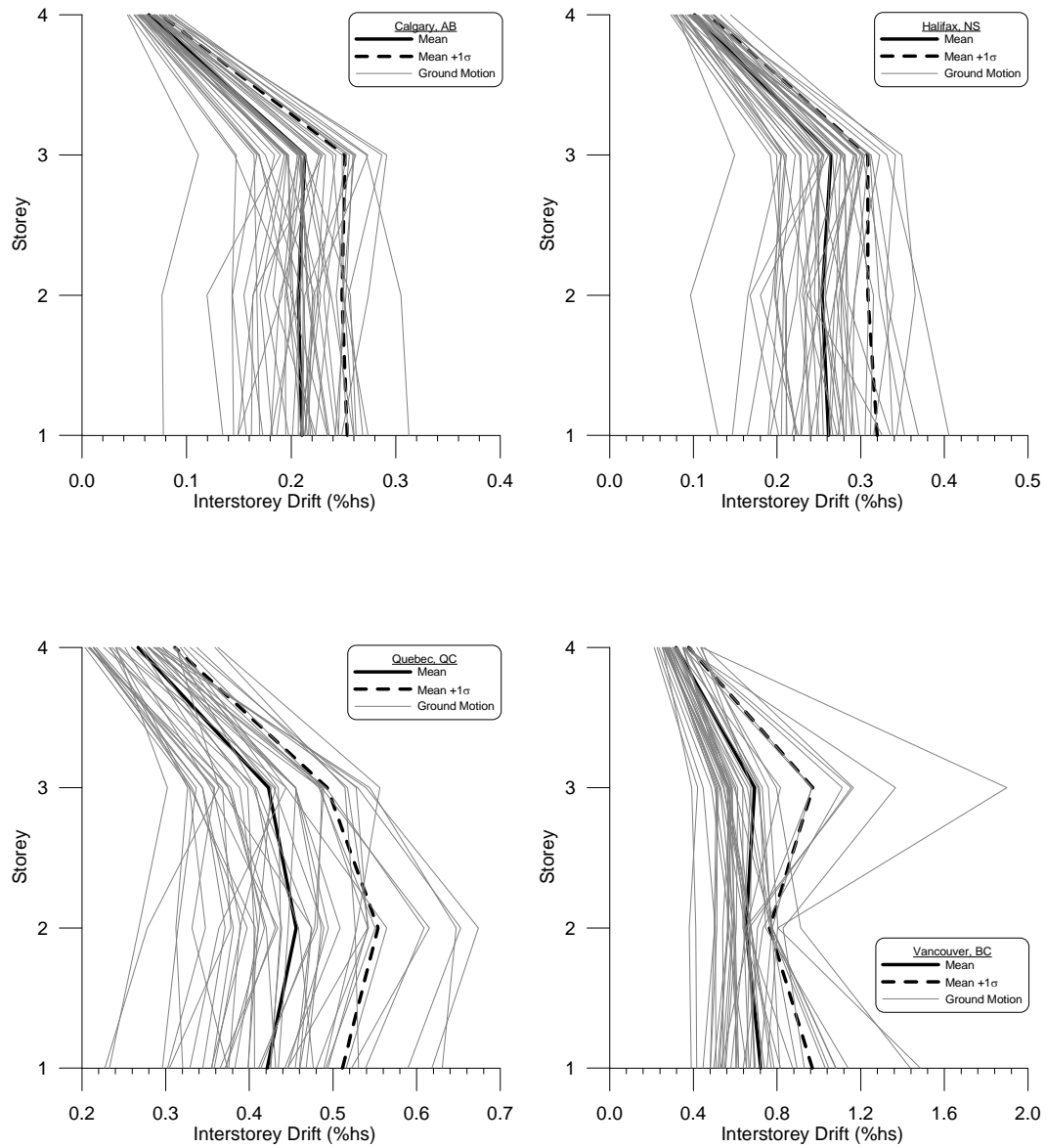

Figure 3.18 Storey drift of four-storey buildings under UHS scaled earthquake records

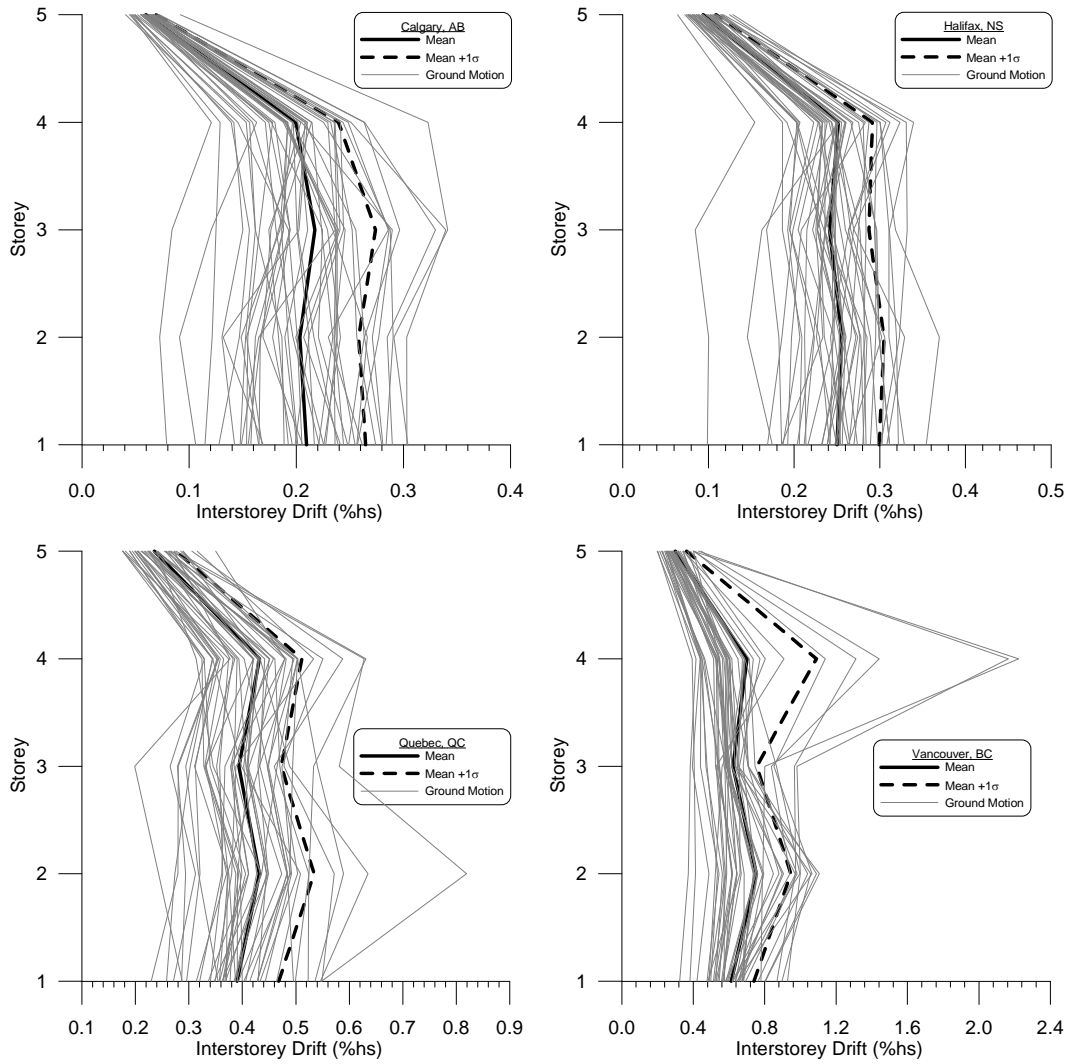

Figure 3.19 Storey drift of five-storey buildings under UHS scaled earthquake records

Table 3.13 Summary of storey drifts

City	Calgary, AB			Halifax, NS			Quebec, QC			Vancouver, BC			
Number of Storeys	2	4	5	2	4	5	2	4	5	2	4	5	
Height, h_n	m	6.7	12.8	15.9	6.7	12.8	15.9	6.7	12.8	15.9	6.7	12.8	15.9
	ft	22.0	42.0	52.2	22.0	42.0	52.2	22.0	42.0	52.2	22.0	42.0	52.2
Number of brace walls	2	2	2	2	3	3	3	4	4	4	7	7	
\square_{\max} (%) RUAUMOKO	1 st	0.40	0.31	0.30	0.47	0.40	0.35	0.49	0.61	0.50	1.75	1.09	0.82
	2 nd	0.10	0.31	0.30	0.27	0.37	0.37	0.97	0.89	0.93	1.19	1.20	1.49
	3 rd	-	0.29	0.34	-	0.35	0.33	-	0.72	0.49	-	2.29	0.95
	4 th	-	0.09	0.32	-	0.14	0.34	-	0.32	0.98	-	0.40	2.28
	5 th	-	-	0.09	-	-	0.13	-	-	0.34	-	-	0.37
\square_{mean} (%) RUAUMOKO	1 st	0.26	0.21	0.21	0.32	0.26	0.25	0.38	0.40	0.37	0.96	0.58	0.51
	2 nd	0.07	0.21	0.20	0.19	0.25	0.26	0.48	0.49	0.46	0.49	0.69	0.88
	3 rd	-	0.21	0.22	-	0.26	0.24	-	0.43	0.37	-	1.04	0.59
	4 th	-	0.06	0.20	-	0.10	0.25	-	0.26	0.48	-	0.30	0.74
	5 th	-	-	0.06	-	-	0.09	-	-	0.22	-	-	0.27
$\square_{\text{mean} + 1\sigma}$ (%) RUAUMOKO	1 st	0.32	0.25	0.26	0.38	0.32	0.30	0.44	0.48	0.43	1.30	0.76	0.59
	2 nd	0.08	0.25	0.26	0.22	0.31	0.30	0.63	0.64	0.62	0.65	0.92	1.16
	3 rd	-	0.25	0.27	-	0.31	0.29	-	0.54	0.42	-	1.04	0.73
	4 th	-	0.07	0.24	-	0.12	0.29	-	0.29	0.66	-	0.30	1.14
	5 th	-	-	0.07	-	-	0.11	-	-	0.26	-	-	0.31

3.5 ATC-63 METHODOLOGY FOR EVALUATION OF R_d , R_o AND HEIGHT LIMIT

ATC-63 (2008) was developed to assess the seismic force modification factors for new SFRSs. This standard was adapted for use with the Canadian design approach and then used to evaluate the R_d and R_o and building height limit currently specified for conventional construction strap braced walls in AISI S213 (2007).

3.5.1. Incremental dynamic analysis

In order to analyse the behaviour of the structures incremental dynamic analyses (Vamvatsikos & Cornell, 2002) of all building models were performed. Each earthquake record, which had previously been scaled to match the UHS was multiplied by a scaling factor SF that varied from $SF = 0.2$ to 8.0. The pre-scaled ground motion records listed in Table 3.7 and Table 3.8 were assigned a scaling factor of 1.0. The damage measure obtained from each dynamic analysis was defined as the maximum inter-storey drift irrespective of the storey in which it took place. The results from the incremental dynamic analysis (IDA) are shown in Figure 3.20 to Figure 3.22; these figures provide the peak storey drift for every ground motion and scale factor.

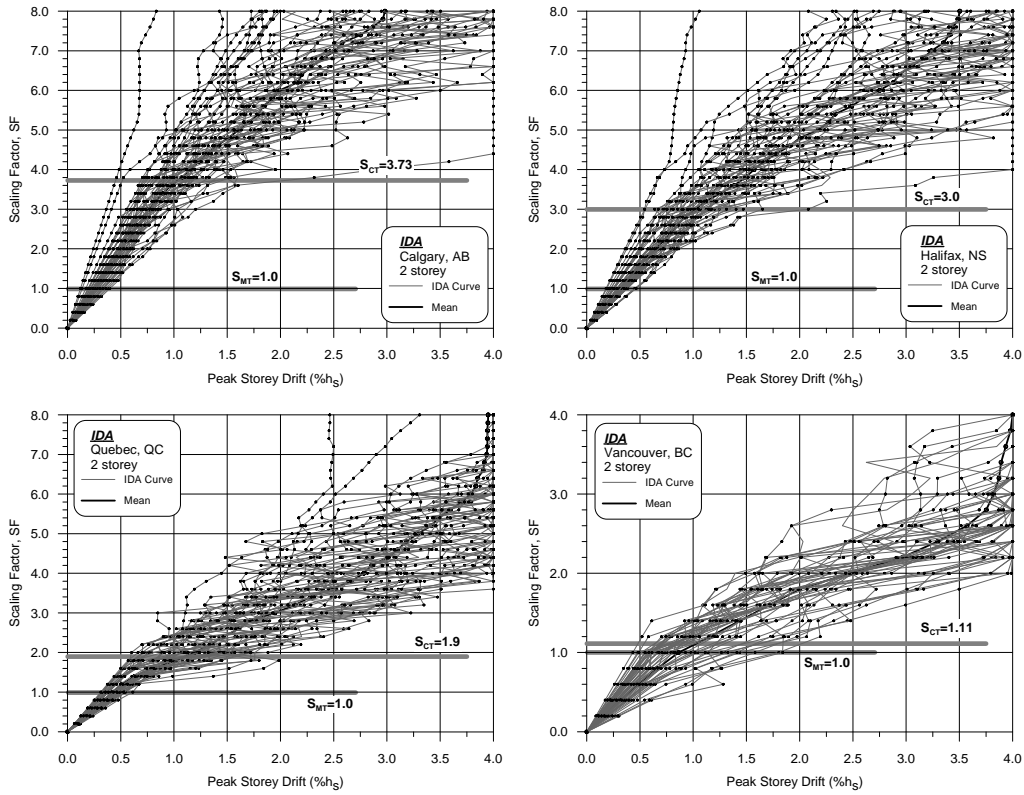

Figure 3.20 IDA analyses for all 2 storey buildings

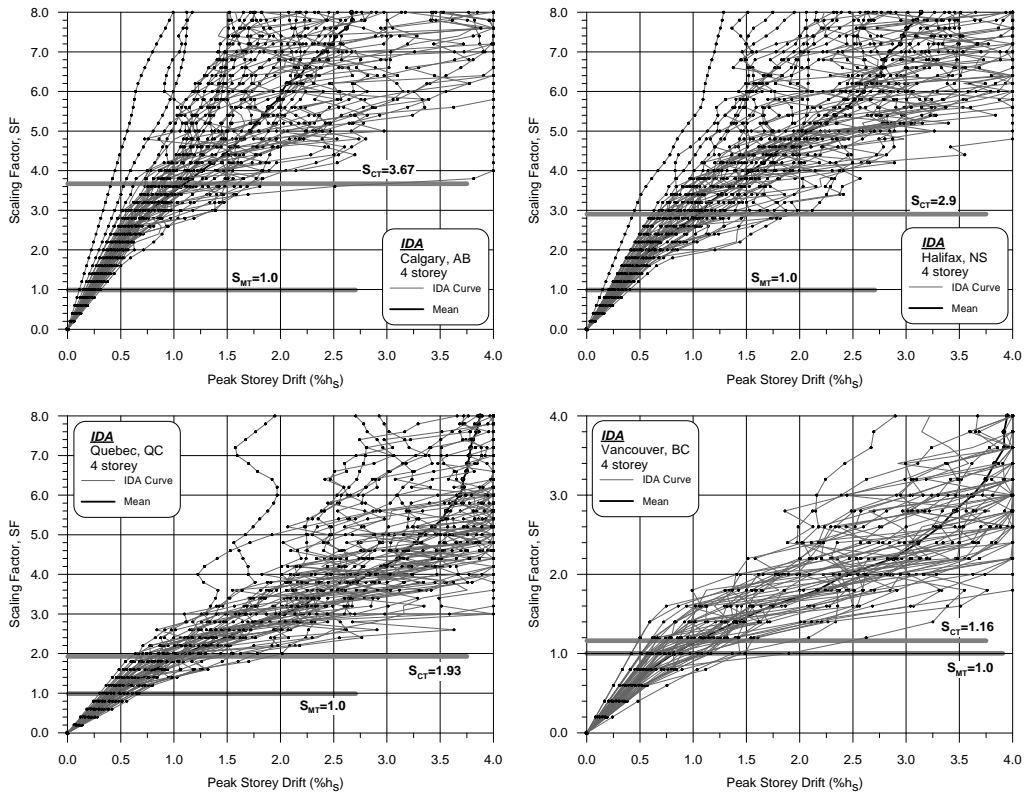

Figure 3.21 IDA analyses all 4 storey buildings

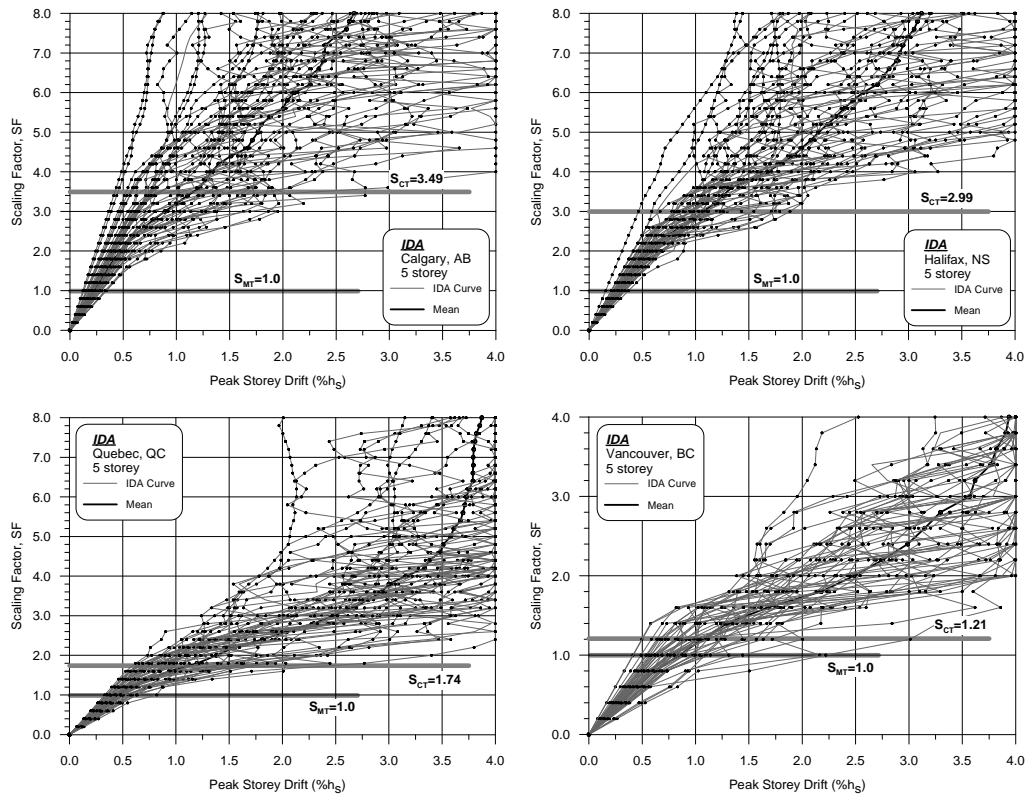

Figure 3.22 IDA analyses for all 5 storey buildings

ATC-63 defines the median collapse for a particular building model as the ground motion intensity at which half of the earthquake records (Table 3.9 & Table 3.10) cause failure to occur. Failure was either defined as instability of the computer model or the attainment of a 1% storey drift in any single storey. The earthquake intensity at this level is denoted as S_{CT} , and it is obtained from the results of the IDA curves. Another important parameter is the maximum considered earthquake (MCE) intensity at the fundamental period of the system S_{MT} . The MCE is defined in ASCE/SEI 7-05 (2006) as having a 2 % probability of exceedance within a 50 year period; which is the same hazard incorporated in the development of the Canadian ground motion data. Because all earthquake records were originally scaled to fit the 2005 NBCC Uniform Hazard Spectrum (Table 3.9 & Table 3.10), S_{MT} was considered to be equal to a scaling factor of 1.0. The collapse margin ratio (CMR) is defined as:

$$CMR = \frac{S_{CT}}{S_{MT}} \quad (3.12)$$

CMR represents the collapse safety of a structure; it is influenced by many uncertainty factors which can be divided into two groups. The first group represents the uncertainty in modeling and the second group represents the effect of spectral shape. These factors can be represented by a fragility curve.

3.5.2. Fragility curve

A fragility curve gives the collapse probability of the SFRS as a function of earthquake intensity and can be defined through a cumulative distribution function (CDF). In Figure 3.23 to Figure 3.25 the lognormal distribution was used to fit the collapse data. The lognormal distribution is defined by the natural logarithm of the median collapse intensity S_{CT} and the standard deviation.

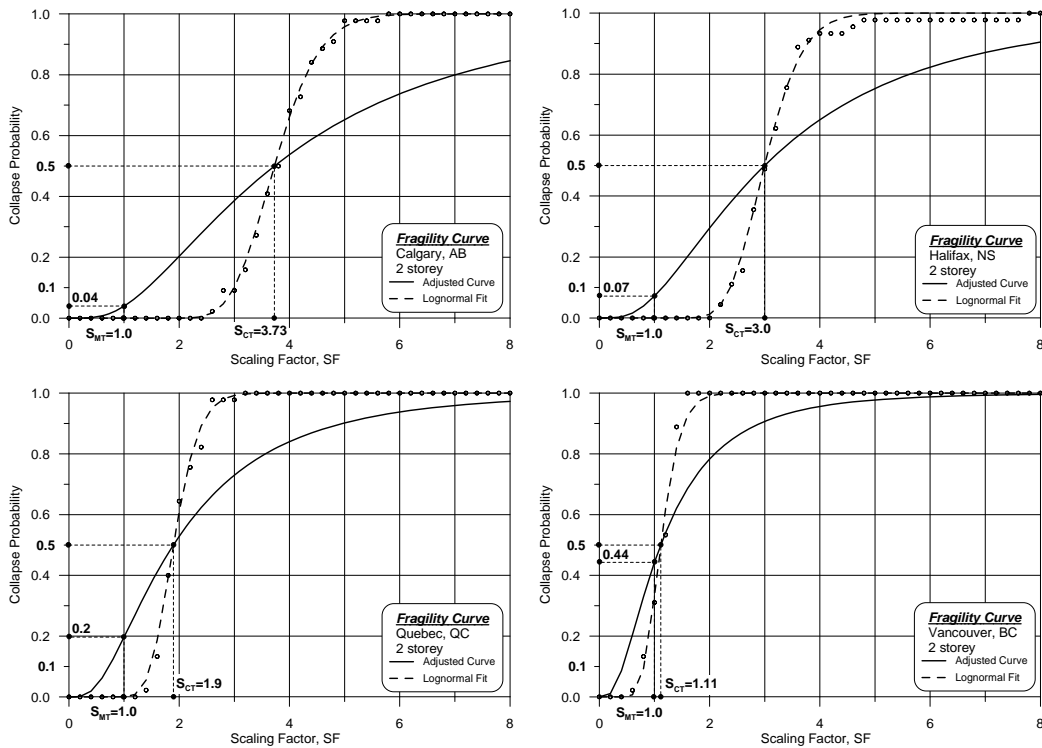

Figure 3.23 Fragility curves for all 2 storey buildings

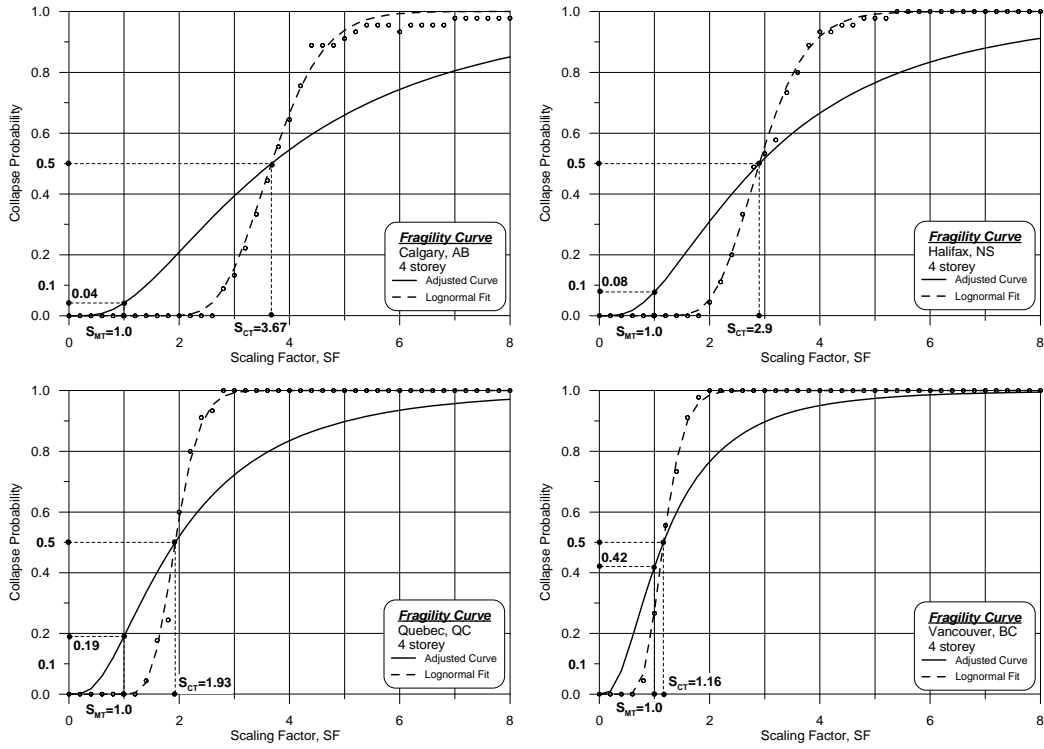

Figure 3.24 Fragility curves for all 4 storey buildings

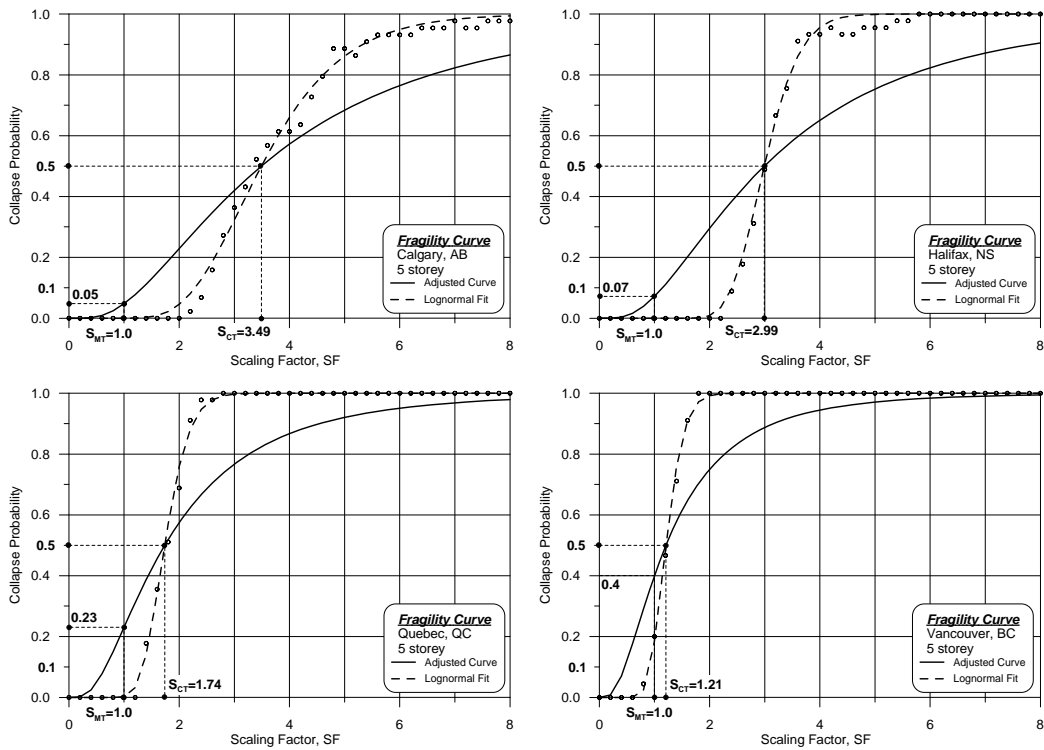

Figure 3.25 Fragility curves for all 5 storey buildings

To account for the modeling and spectral shape effects two adjustments are made. The first adjustment is due to the effect of the spectral shape on the collapse margin. The spectral shape factor, SSF, depends on the fundamental period and ductility of the structure, and the seismic design category. Because the conventional construction strap braced structures exhibit only a minimal amount of ductility, as described by Al-Kharat and Rogers (2007, 2008) the worst case scenario was considered and the spectral shape coefficient was assumed to be equal to 1.0. The second adjustment, the total collapse uncertainty β_{TOT} , is related to model uncertainty, which depends on the quality of the model, test data and design requirements. Following the recommendations of ATC-63 the quality of test data and design requirements was determined as good. Taking into account that the net cross section fracture of the braces was not modeled, i.e. strength degradation was not considered, the quality of the model was defined as fair. According to ATC-63 the total system collapse uncertainty would be listed as $\beta_{tot} = 0.75$. These two factors are applied to the CMR and the standard deviation of the data set thus changing the shape of the fragility curve as shown in Figure 3.23 to Figure 3.25. The resulting collapse margin ratio, median collapse intensity and average values for the building models evaluated on a city by city basis are listed in Table 3.14.

Table 3.14 ATC 63 parameters for determining model acceptance

City		Calgary, AB	Halifax, NS	Quebec, QC	Vancouver, BC
S _{CT}	2 storey	3.73	3.00	1.90	1.11
	4 storey	3.67	2.90	1.93	1.16
	5 storey	3.49	2.99	1.74	1.21
S _{MT}		1.0	1.0	1.0	1.0
CMR = S _{CT} / S _{MT}	2 storey	3.73 > 1.88	3.00 > 1.88	1.90 > 1.88	1.11 < 1.88
	4 storey	3.67 > 1.88	2.90 > 1.88	1.93 > 1.88	1.16 < 1.88
	5 storey	3.49 > 1.88	2.99 > 1.88	1.74 < 1.88	1.21 < 1.88
CMR average		3.63 > 2.61	2.96 > 2.61	1.86 < 2.61	1.16 < 2.61
Collapse Probability for MCE	2 storey	0.04 < 0.2	0.07 < 0.2	0.2 = 0.2	0.44 > 0.2
	4 storey	0.04 < 0.2	0.08 < 0.2	0.19 < 0.2	0.42 > 0.2
	5 storey	0.05 < 0.2	0.07 < 0.2	0.23 > 0.2	0.4 > 0.2
Average Collapse Probability for MCE		0.04 < 0.1	0.07 < 0.1	0.21 > 0.1	0.42 > 0.1
Collapse Probability ACMR 20%		1.88			
Collapse Probability ACMR 10%		2.61			

3.5.3. Evaluation of the structure performance following ATC-63

According to Chapter 7.5 in ATC-63 the performance of a building is acceptable, and thus the seismic design approach including R values and height limit is appropriate, if the probability of collapse for the MCE (Section 3.5.2) does not exceed 10 % and 20 % for the average and for each individual archetype, respectively. Furthermore, for an acceptable performance ATC- 63 requires:

$$\overline{ACMR}_i \geq ACMR10\% \quad (3.13)$$

$$ACMR_i \geq ACMR20\% \quad (3.14)$$

where \overline{ACMR}_i is the average value of the adjusted collapse margin ratio, $ACMR_i$ are the individual values of adjusted collapse margin ratio, $ACMR10\%$ and $ACMR20\%$ are the acceptable values of adjusted collapse margin ratio given in Table 7-3 in ATC-63. In our case from Table 7-3 in ATC-63 $\beta_{tot} = 0.75$, $ACMR10\% = 2.61$ and $ACMR20\% = 1.88$. All data is summarized in Table 3.14, and as it can be seen, the building performance given the design parameters of a storey height of 15 m, $R_d = 1.25$ and $R_o = 1.3$ is acceptable only for Calgary and Halifax. The buildings modeled in Quebec and Vancouver did not exhibit adequate performance such that structures having a SFRS constructed with conventional construction braced walls could be allowed. This result confirms that the AISI S213 provisions for the seismic design of conventional construction cold-formed steel strap braced walls are appropriate.

Chapter 4 Conclusions and Recommendations

4.1. CONCLUSIONS

4.1.1 Test Program

In the summer of 2007 thirty screw connected cold-formed steel strap braced walls specimens (2.44 m x 2.44 m) were fabricated and tested at McGill University. These tests are an addition to the thirty one specimens tested by Al-Kharat & Rogers (2007, 2008). The data obtained from the monotonic and reversed cyclic tests were used to confirm the seismic capacity based design methods for CFS limited ductility CBFs currently required by the AISI S213 Standard (2007). Three different factored load levels (20 kN, 40 kN and 75 kN) were used in the design of the type LD test walls. The scope of testing also comprised walls braced with regular and fuse braces.

This study showed that in order to achieve high ductility and energy dissipation a capacity based design approach should be used, as is required by AISI S213 for type LD walls. Based on test results yielding of the braces was observed in almost all specimens, whether constructed with regular or fuse braces. In a limited number of cases, the detailing of the light walls could be improved to ensure better ductile behaviour. Screwed connections performed as was expected, but the designer should make sure that when screw attached regular braces are used the gross cross section yielding of the braces should control the design as per AISI S213. It was found that the tracks can be reinforced to provide sufficient compression capacity with respect to the probable brace force at yielding. Their fabrication, however, is very time consuming, difficult and uneconomical because a significant length of reinforcement and number of screws is needed to distribute the compression force among the shear anchors. It is recommended that the thickness be increased as a means to improve the compression resistance of the track, or that extended tracks be installed instead. It can be concluded that raising

the holddown position above the track (by 2") had no significant effect on the overall wall performance under lateral loading. The effect of the prying force on the anchor rod due to different holddown position is minimal for storey drifts less than 3%. The factors for expected yield strength and tensile strength R_y and R_t , respectively, listed in AISI S213 provide for a reasonable estimate of the probable strength of the brace and should be used for the capacity design procedure. Installing screws into the interior studs through the braces in most situations does not affect the overall ductility of a braced wall. However, when braces with reduced width fuses are used these fuse segments should be considered as protected zones unless it can be shown that their length is adequate such that fracture of the brace at the screw hole would not take place prior to reaching the expected inelastic drift levels. The seismic force modification factors for limited ductility braced walls $R_d = 2.0$ and $R_o = 1.3$ were shown to be valid given the measured ductility and overstrength of the test walls.

4.1.2 Dynamic Analyses

Dynamic analyses were used to evaluate the AISI S213 Canadian seismic force modification factors $R_d = 1.25$, $R_o = 1.3$ and building height limit of 15m for conventional construction strap braced wall systems. Inter-storey drifts were examined, followed by the use of the ATC-63 procedure for determining the validity of R factors and the general seismic design approach. The ATC-63 procedure relies on IDA and collapse fragility curves to provide an estimate of the probability of failure under design level ground motions. Using Ruaumoko (*Carr, 2000*) nonlinear time-history dynamic analyses were performed for two, four and five storey buildings situated in four selected Canadian cities. The bi-linear with slackness hysteresis element was calibrated and incorporated in the computer model. Real, simulated and spectrum matched UHS-compatible ground motion time histories were used. The design of the SFRS of all buildings was carried out following the 2005 NBCC with $R_d = 1.25$ and $R_o = 1.3$ as is recommended in AISI S213 (*2007*) for conventional construction braced walls. The results of the ATC-

63 (2008) evaluation procedure confirm that the height limit of 15 metres for buildings in low seismic zones is appropriate. If construction in higher seismic zones must be carried out or the buildings exceed 15 m, then the more stringent design approach for limited ductility CBFs must be followed. Furthermore, the results of the procedure confirm the seismic force modification factors for type CC walls currently listed in AISI S213 (2007).

4.2. RECOMMENDATIONS FOR FUTURE STUDIES

This research forms an experimental and analytical study of CFS strap braced walls. Only two, four and five storey high buildings situated in four selected Canadian cities were modeled and subjected to ground motions. Following the recommendations of ATC-63 more models should be developed (different storey heights and different aspect ratios of the walls). Also, the representative building was symmetrical and without any irregularities; as well braced bents were continuous through the building height. In order to investigate completely the inelastic behaviour of buildings having CFS strap braced walls as a SFRS it is necessary to evaluate buildings with irregularities using 3D models that account for the behaviour of floor and roof diaphragms.

Even if a complex computer model is developed to predict the behaviour of a structure under seismic excitation, it is difficult and sometimes impossible to replicate the real behaviour during an earthquake. For example, in a real structure all non load-bearing walls will contribute to the lateral stiffness of the building, however they often would not be considered or modeled properly in a dynamic analysis. This is why dynamic shake table testing is needed to fully examine the behaviour of braced walls, and ultimately to improve the calibration of dynamic models.

REFERENCES

- Adham, S.A., Avanesian, V., Hart, G.C., Anderson R.W., Elmlinger, J., Gregory, J. (1990). "Shear Wall Resistance of Lightgauge Steel Stud Wall Systems", *Earthquake Spectra*, 6:1, 1-14.
- Al-Kharat, M., Rogers, C.A., (2008) "Inelastic Performance of Screw Connected Cold-Formed Steel Strap Braced Walls", *Canadian Journal of Civil Engineering*, Vol. 35 No. 1, 11-26.
- Al-Kharat, M., Rogers, C.A. (2007). "Inelastic Performance of Cold-Formed Steel Strap Braced Walls", *Journal of Constructional Steel Research*, Vol. 63 No. 4, 460-474.
- Al-Kharat, M., Rogers, C.A., (2006). "Inelastic Performance of Screw Connected Light Gauge Steel Strap Braced walls", Research Report, Dept. of Civil Engineering & Applied Mechanics, McGill University, Montreal, QC, Canada.
- Al-Kharat, M., Rogers, C.A. (2005). "Testing of Light Gauge Steel Strap Braced Walls", Research Report, Dept. of Civil Engineering & Applied Mechanics, McGill University, Montreal, QC, Canada.
- American Iron and Steel Institute (2007). "AISI S213-07, North American Standard for Cold-Formed Steel Framing – Lateral Design", Washington DC, USA.
- American Society of Civil Engineers ASCE/SEI 7-05 (2006). "Minimum Design Loads for Buildings and Other Structures", Reston, VA, USA.
- American Society for Testing and Materials A193/A193M (2006). "Standard Specification for Alloy-Steel and Stainless Steel Bolting Materials for High Temperature or High Pressure Service and Other Special Purpose Applications", West Conshohocken, PA, USA.

- American Society for Testing and Materials A325 (2002). “Standard Specification for Structural Bolts, Steel, Heat Treated 120/105 ksi Minimum Tensile Strength”, West Conshohocken, PA, USA.
- American Society for Testing and Materials A370 (2002). “Standard Test Methods and Definitions for Mechanical Testing of Steel Products”, West Conshohocken, PA, USA.
- American Society for Testing and Materials E2126 (2005). “Standard Test Methods for Cyclic (Reversed) Load Test for Shear Resistance of Framed Walls for Buildings” West Conshohocken, PA, USA.
- Applied Technology Council (2008). “Quantification of Building Seismic Performance Factors, ATC-63 Project Report - 90% Draft” Redwood City, CA, USA.
- Atkinson, G. M. (2008). “Earthquake Time Histories Compatible with the 2005 NBCC Uniform Hazard Spectrum”, *Canadian Journal of Civil Engineering*, In press.
- Barton, A.D. (1997). “Performance of Steel Framed Domestic Structures Subject to Earthquake Loads”. PhD Thesis, Department of Civil and Environmental Engineering, University of Melbourne, Melbourne, Australia.
- Canadian Institute of Steel Construction (2006). “Handbook of Steel Construction”, 9th edition, Toronto, ON, Canada.
- Canadian Standards Association S16 (2005). “Limit States Design of Steel Structures”, Mississauga, ON, Canada.
- Canadian Standards Association S136 (2007). “North American Specification for the Design of Cold-Formed Steel Structural Members”, Mississauga, ON, Canada.
- Canam Group (2004). “Hambro D500 floor system”, www.hambrosystems.com.

- Carr, A. J. (2000). "RUAUMOKO – Inelastic Dynamic Analysis, Version March 15th 2000", Department of Civil Engineering, University of Canterbury, Christchurch, New Zealand.
- Casafont, M., Arnedo, A., Roure, F., Rodríguez-Ferran, A. (2006). "Experimental Testing of Joints for Seismic Design of Lightweight Structures. Part 1. Screwed Joints in Straps", *Thin-Walled Structures*, 44, 197-210.
- Cobeen, K., Van de Lindt, J. W., Cronin, K. (2007). "Design of a Six-Story Woodframe Building based on the 2006 IBC Methodology", NEESwood report NW-03, In press.
- Comeau, G. (2008). "Inelastic Performance of Welded Cold-Formed Steel Strap Braced Walls". M.Eng Thesis, Dept. of Civil Engineering & Applied Mechanics, McGill University, Montreal, QC, Canada.
- Fülöp, L.A., Dubina, D. (2004). "Performance of Wall-Stud Cold-Formed Shear Panels Under Monotonic and Cyclic Loading. Part I: Experimental Research", *Thin-Walled Structures*, 42, 321-338.
- Gad, E.F., Duffield, C.F., Hutchinson, G.L, Mansell, D.S., Stark, G. (1999). "Lateral Performance of Cold-Formed Steel-Framed Domestic Structures", *Journal of Engineering Structures*, 21, 83-95.
- Hikita, K. E. (2006). "Impact of Gravity Loads on the Lateral Performance of Light Gauge Steel Frame / Wood Panel Shear Walls", M.Eng. Thesis, Dept. of Civil Engineering & Applied Mechanics, McGill University, Montreal, Canada.
- Kim, T.-W., Wilcoski, J., Foutch, D. A., (2007) "Analysis of Measured and Calculated Response of a Cold-formed Steel Shear Panel Structure", *Journal of Earthquake Engineering*, 11:1, 67–85.
- Kim, T.-W., Wilcoski, J., Foutch, D. A., Sung Lee, M. (2006). "Shaketable tests of a cold-formed steel shear pane", *Engineering Structures*, Vol. 28, No. 10, 1462-1470.

- Krawinkler, H., Parisi, F., Ibarra, L., Ayoub, A., Medina, R. (2000). “Development of a Testing Protocol for Woodframe Structures”, Report W-02 covering Task 1.3.2, CUREE/Caltech Woodframe Project. Consortium of Universities for Research in Earthquake Engineering (CUREE), Richmond, CA, USA.
- Léger, P., Tayebi, A. K., Paultre, P. (1993). “Spectrum-compatible Accelerograms for Inelastic Seismic Analysis of Short-period Structures located in eastern Canada”, *Canadian Journal of Civil Engineering*, Vol. 20, 951-968.
- Mitchell, D., Tremblay, R., Karacabeyli, E., Paultre, P., Saatcioglu, M., Anderson, D. L. (2003). “Seismic Force Modification Factors for the Proposed 2005 Edition of the National Building Code of Canada”, *Canadian Journal of Civil Engineering*, Vol. 30, No. 2, 308-327.
- National Research Council of Canada (1995). “National Building Code of Canada 1995”, Ottawa, On, Canada.
- National Research Council of Canada (2005a). “National Building Code of Canada 2005”, 12th Edition, Ottawa, On, Canada.
- National Research Council of Canada (2005b). “User’s Guide – NBC 2005 Structural Commentaries (Part 4 of Division B)”, 2nd Edition, Ottawa, On, Canada.
- Newmark, N. M., Hall, W. J. (1982). “Earthquake Spectra and Design”, Engineering Monograph MNO-3, Earthquake Engineering Research Institute, Berkeley, CA, USA.
- Pastor, N., Rodríguez-Ferran, A. (2005). “Hysteretic Modelling of X-Braced Shear Walls”, *Thin-Walled Structures*, 43, 1567-1588.
- Pacific Earthquake Engineering Research Center (PEER) (2005). “PEER NGA database”, <http://peer.berkeley.edu/nga>. Accessed March, 2008.
- Prakash, V., Powell, G. H., and Campbell, S. (1993) “DRAIN-2DX Base Program Description and User Guide”, Version 1.10, Report no. UCB/SEMM-

93/17 and 93/18, Department of Civil Engineering, University of California, Berkeley, CA, USA.

Serrette, R., Ogunfunmi, K. (1996) “Shear Resistance of Gypsum-Sheathed Light-Gauge Steel Stud Walls”, *Journal of Structural Engineering, ASCE*, 122:4, 383-389.

Simpson Strong-Tie Co., Inc. (2005) “S/HDS & S/HDB Holdowns Specification” Catalog C-CFS06, Pleasanton, CA, USA. 23.

TI 809-07 (2003), “Technical instructions : Design of cold-formed loadbearing steel systems and masonry veneer / steel stud walls”, US Army Corps of Engineers, Engineering and Construction Division, Directorate of Civil Works, Washington DC, USA.

Tian, Y.S., Wang, J., Lu, T.J. (2004) “Racking Strength and Stiffness of Cold-Formed Steel Wall Frames”, *Journal of Constructional Steel Research*, 60, 1069-1093.

Vamvatsikos D., Cornell, C. A. (2002) “Incremental Dynamic Analysis”, *Earthquake Engineering and Structural Dynamics*, 31:4, 491-514.

Whitmore, R.E. (1952) “Experimental Investigation of Stresses in Gusset Plates” The University of Tennessee Engineering Experiment Station, Knoxville TN, Bulletin No. 16.

APPENDIX A
INDIVIDUAL TEST RESULTS SUMMARIES

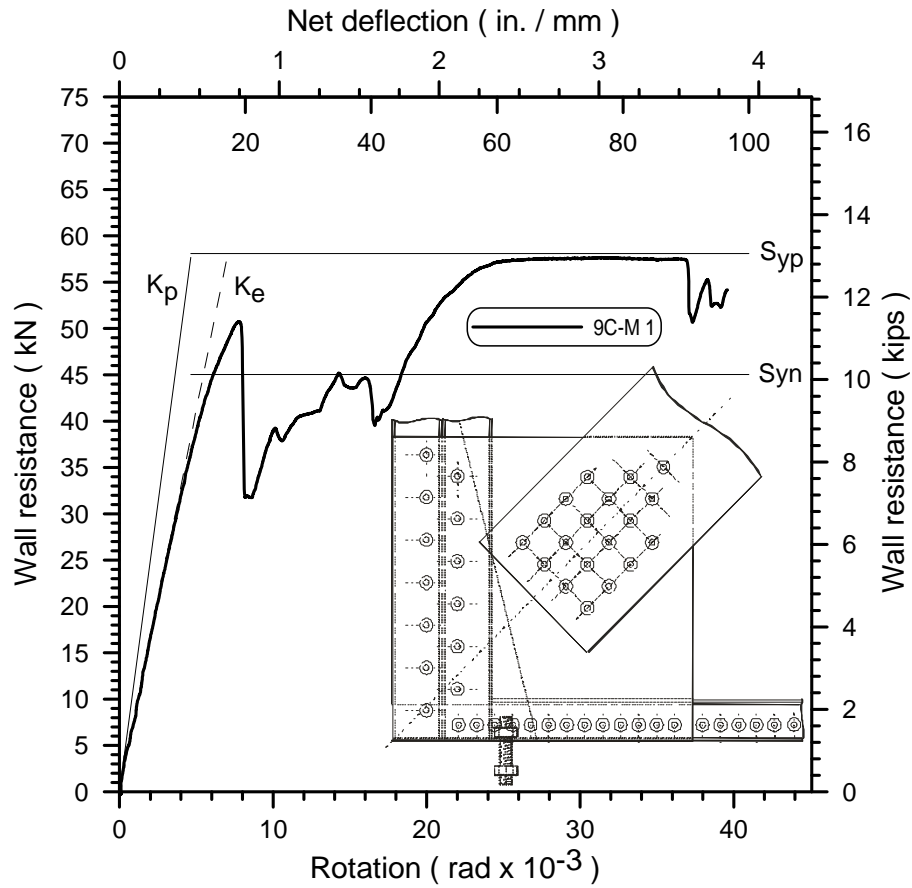

Figure A.1 Monotonic test results specimen 9C-M 1

Table A.1 Monotonic test results specimen 9C-M 1

Test Result	Specimen		9 C-M 1	9 C-M 2	Units
		S_{max}		57.65	NA
	Δ_{max}		97.83	NA	mm
	S_v		57.50	NA	kN
	$S_{0.40}$		23.06	NA	kN
	$\Delta_{S0.40}$		6.82	NA	mm
	K_e		3.38	NA	kN/mm
	Ductility μ		5.75	NA	mm/mm
Prediction (Actual Dimensions)	S_{yp}		58.06	NA	kN
	K_p		5.08	NA	kN/mm
Prediction (Nominal Dimensions)	S_{yn}		45.03	NA	kN
	K_n		5.14	NA	kN/mm
Strain Gauge Results Specimen 9 C-M 1					
Gauge	SG1	SG2	SG3	SG4	SG5
Max Strain (mm/mm)	15832	8053	13923	NA	NA
Yielding Strain (mm/mm)	1494	1494	1494	NA	NA
Yielding Status	OK	OK	OK	NA	NA

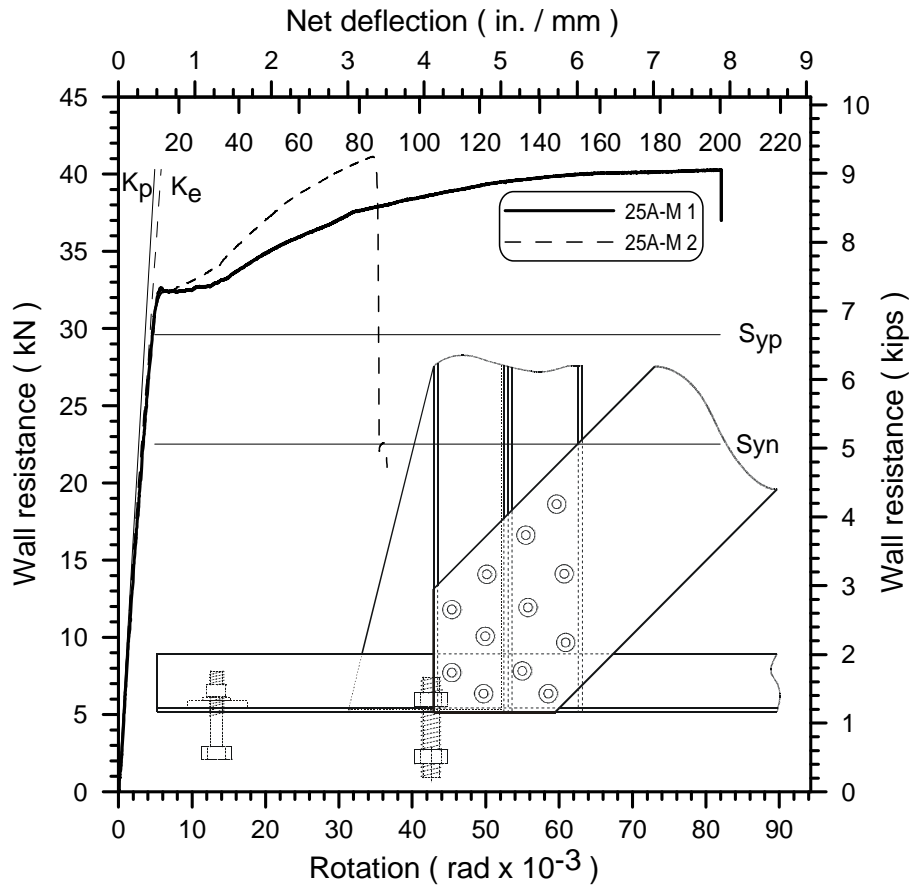

Figure A.2 Monotonic test results specimen 25A-M 1 and 25A-M 2

Table A.2 Monotonic test results specimen 25A-M 1 and 25A-M 2

Test Result	Specimen	25 A-M 1	25 A-M 2	Units	
	S_{max}	40.30	41.13	kN	
	Δ_{max}	210.37	89.24	mm	
	S_y	32.40	32.40	kN	
	$S_{0.40}$	16.12	16.45	kN	
	$\Delta_{S0.40}$	5.66	5.31	mm	
	K_e	2.85	3.10	kN/mm	
	Ductility μ	18.48	8.54	mm/mm	
Prediction (Actual Dimensions)	S_{yp}	29.60	29.55	kN	
	K_p	3.34	3.34	kN/mm	
Prediction (Nominal Dimensions)	S_{yn}	22.51		kN	
	K_n	3.31		kN/mm	
Strain Gauge Results Specimen 25 A-M 1					
Gauge	SG1	SG2	SG3	SG4	SG5
Max Strain (mm/mm)	1450	1327	15413	9456	15790
Yielding Strain (mm/mm)	1456	1456	1456	1456	1456
Yielding Status	NO	NO	OK	OK	OK

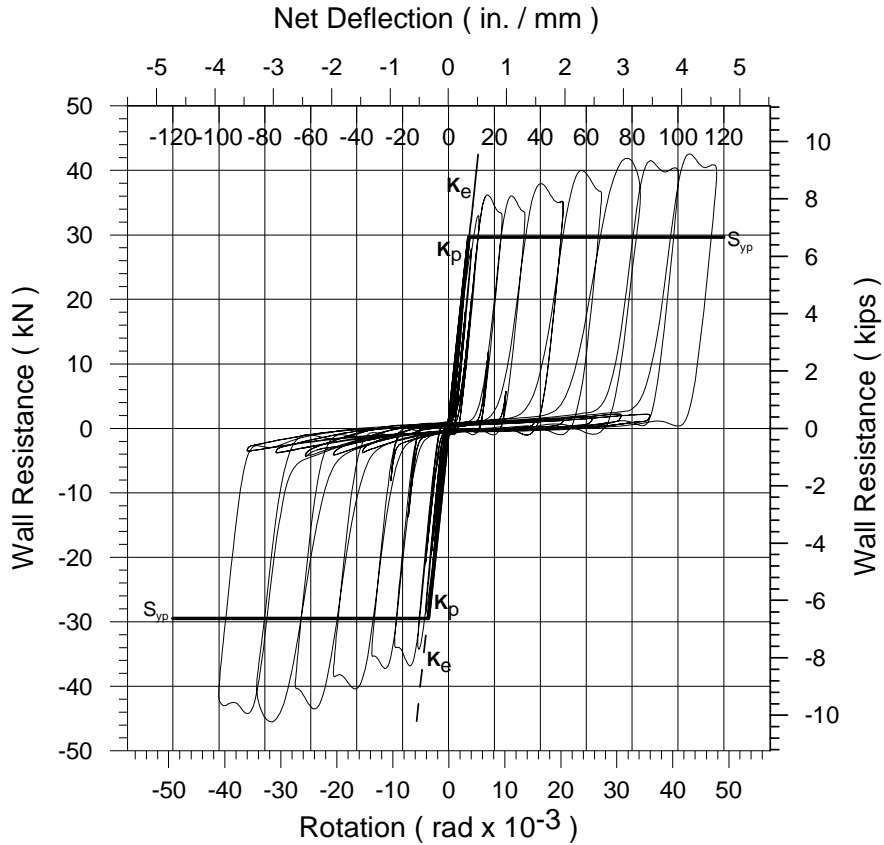

Figure A.3 Cyclic test results specimen 26A-C

Table A.3 Cyclic test results specimen 26A-C

Test Result	Parameters	Negative	Positive	Units		
		S_{max}	-45.52	42.53	kN	
	Δ_{max}	-116.89	116.83	mm		
	$S_{0.40}$	-18.21	17.01	kN		
	$\Delta_{S0.40}$	-5.59	5.20	mm		
	K_e	3.26	3.27	kN/mm		
	Ductility μ	12.92	12.90	mm/mm		
Prediction (Actual Dimensions)	S_{yp}	-29.46	29.64	kN		
	K_p	3.34	3.34	kN/mm		
Prediction (Nominal Dimensions)	S_{yn}	22.51		kN		
	K_n	3.31		kN/mm		
Strain Gauge Results						
Gauge	SG1	SG2	SG3	SG4	SG5	SG6
Max Strain (mm/mm)	1332	10763	16391	2253	16245	16085
Yielding Strain (mm/mm)	1456	1456	1456	1456	1456	1456
Yielding Status	NO	OK	OK	OK	OK	OK

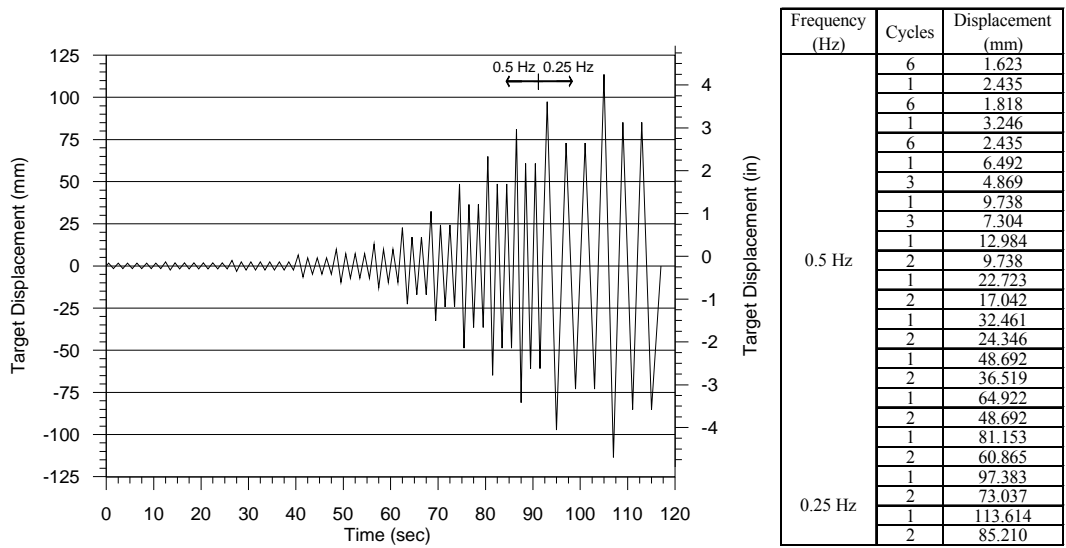

Figure A.4 Reversed cyclic CUREE test protocol for specimen 26 A-C

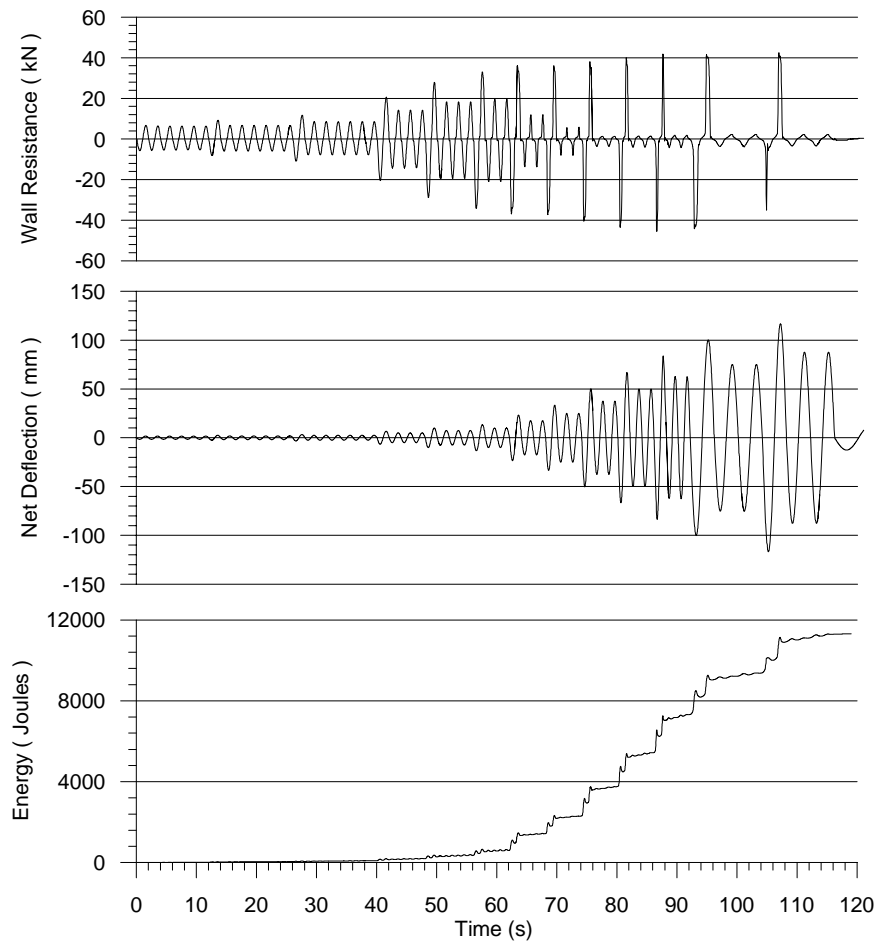

Figure A.5 Time history of specimen 26 A-C

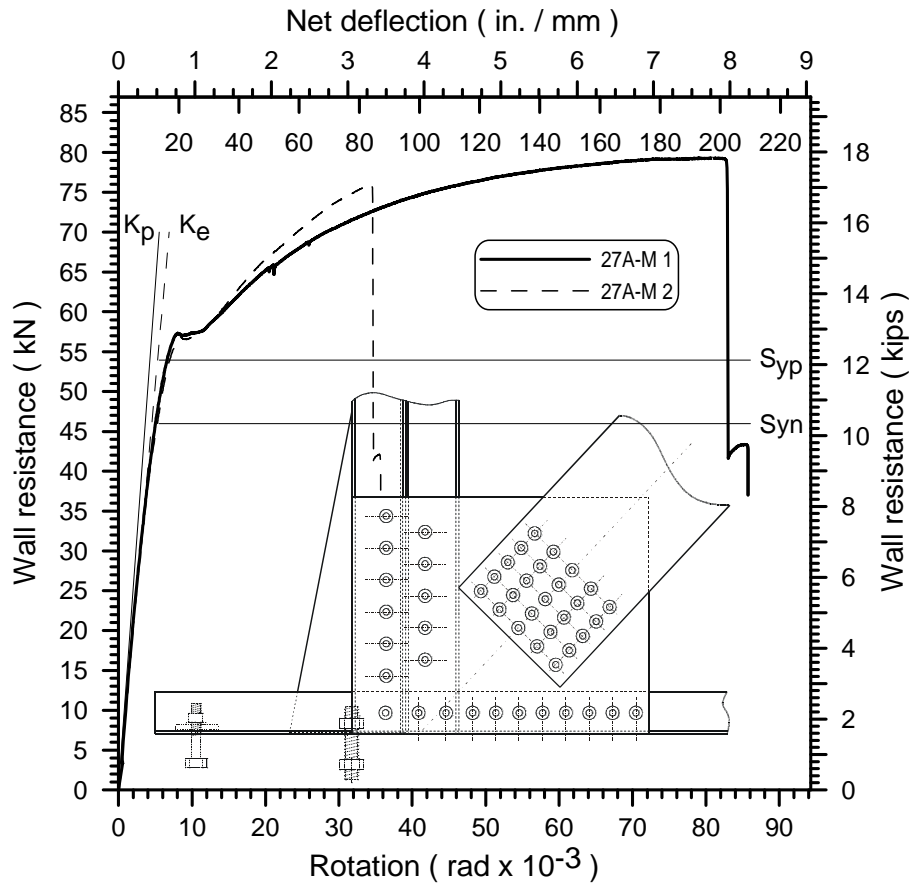

Figure A.6 Monotonic test results specimen 27A-M 1 and 27A-M 2

Table A.4 XX Monotonic test results specimen 27A-M 1 and 27A-M 2

Test Result	Specimen		27 A-M 1	27A-M 2	Units
		S_{max}		79.30	76.01
	Δ_{max}		210.71	87.52	mm
	S_y		57.00	56.60	kN
	$S_{0.40}$		31.72	30.40	kN
	$\Delta_{S0.40}$		7.62	7.43	mm
	K_e		4.16	4.09	kN/mm
	Ductility μ		15.39	6.33	mm/mm
Prediction (Actual Dimensions)	S_{yp}		53.94	53.86	kN
	K_p		5.20	5.20	kN/mm
Prediction (Nominal Dimensions)	S_{yn}		45.98		kN
	K_n		5.12		kN/mm
Strain Gauge Results Specimen 27A-M 1					
Gauge	SG1	SG2	SG3	SG4	SG5
Max Strain (mm/mm)	4004	2830	16356	16215	16146
Yielding Strain (mm/mm)	1906	1906	1906	1906	1906
Yielding Status	OK	OK	OK	OK	OK

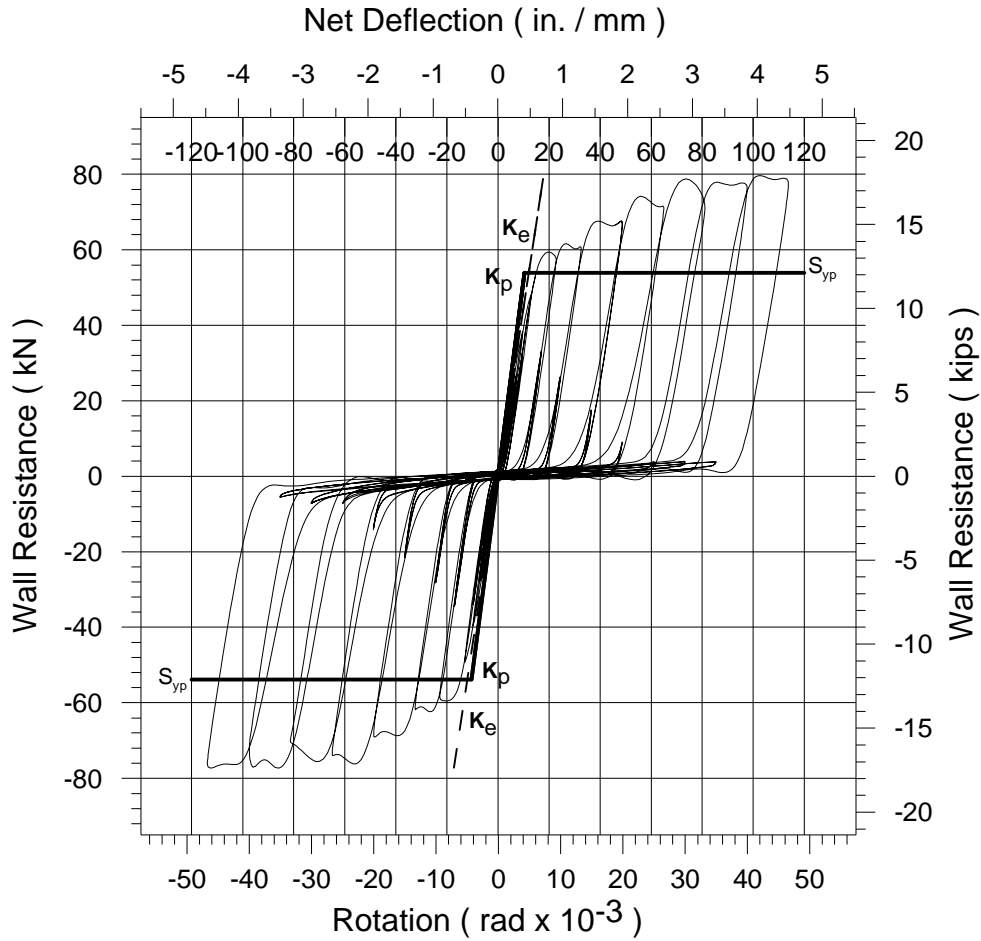

Figure A.7 Cyclic test results specimen 28A-C

Table A.5 Cyclic test results specimen 28A-C

Test Result	Parameters	Negative	Positive	Units		
	S_{max}		-77.29	79.62	kN	
Δ_{max}		-113.77	113.74	mm		
$S_{0.40}$		-30.92	31.85	kN		
$\Delta_{S0.40}$		-6.90	7.16	mm		
K_e		4.48	4.45	kN/mm		
Ductility μ		9.46	9.38	mm/mm		
Prediction (Actual Dimensions)	S_{yp}	-53.86	53.94	kN		
	K_p	5.20	5.21	kN/mm		
Prediction (Nominal Dimensions)	S_{yn}	45.98		kN		
	K_n	5.12		kN/mm		
Strain Gauge Results						
Gauge	SG1	SG2	SG3	SG4	SG5	SG6
Max Strain (mm/mm)	2975	16005	16340	2808	15997	16606
Yielding Strain (mm/mm)	1906	1906	1906	1906	1906	1906
Yielding Status	OK	OK	OK	OK	OK	OK

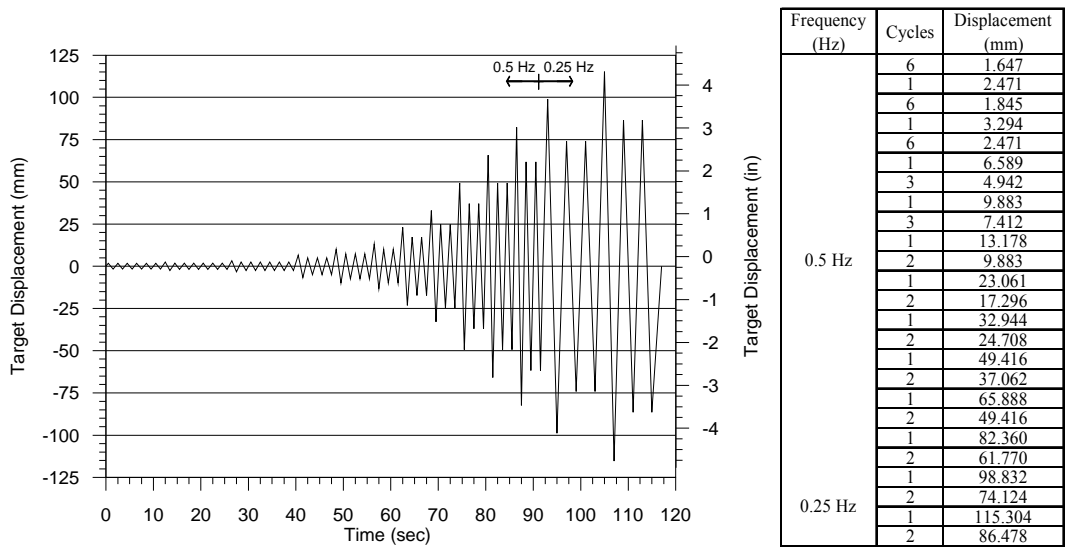

Figure A.8 Reversed cyclic CUREE test protocol for specimen 28 A-C

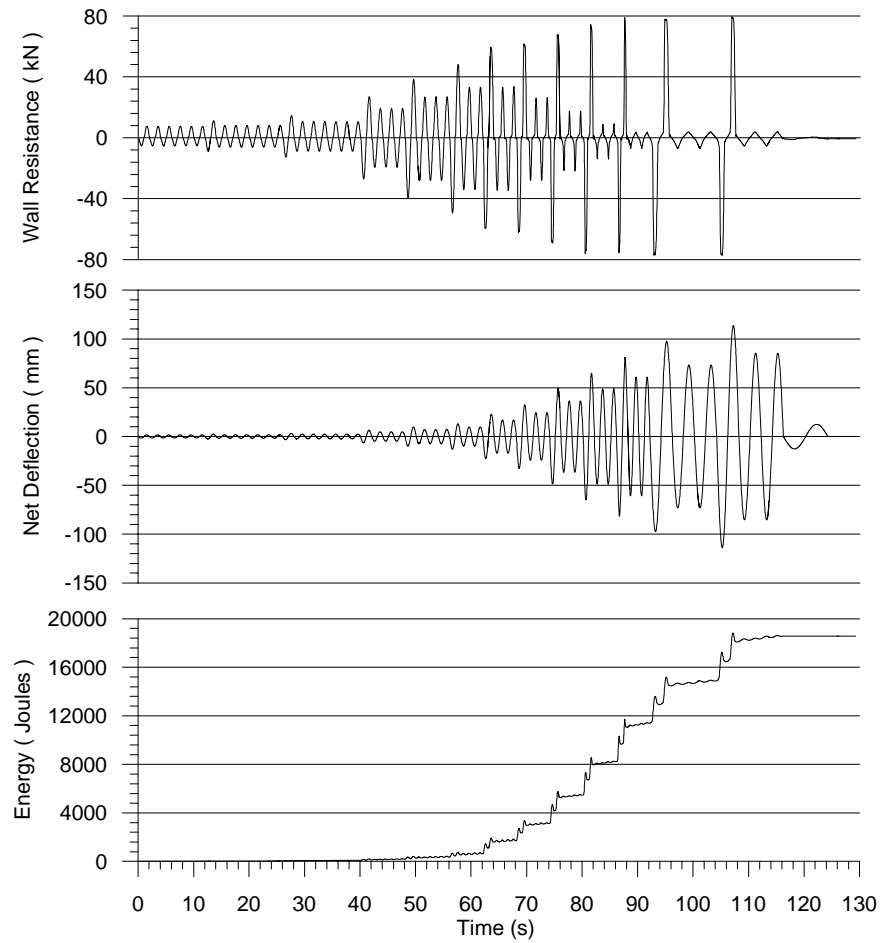

Figure A.9 Time history of specimen 28 A-C

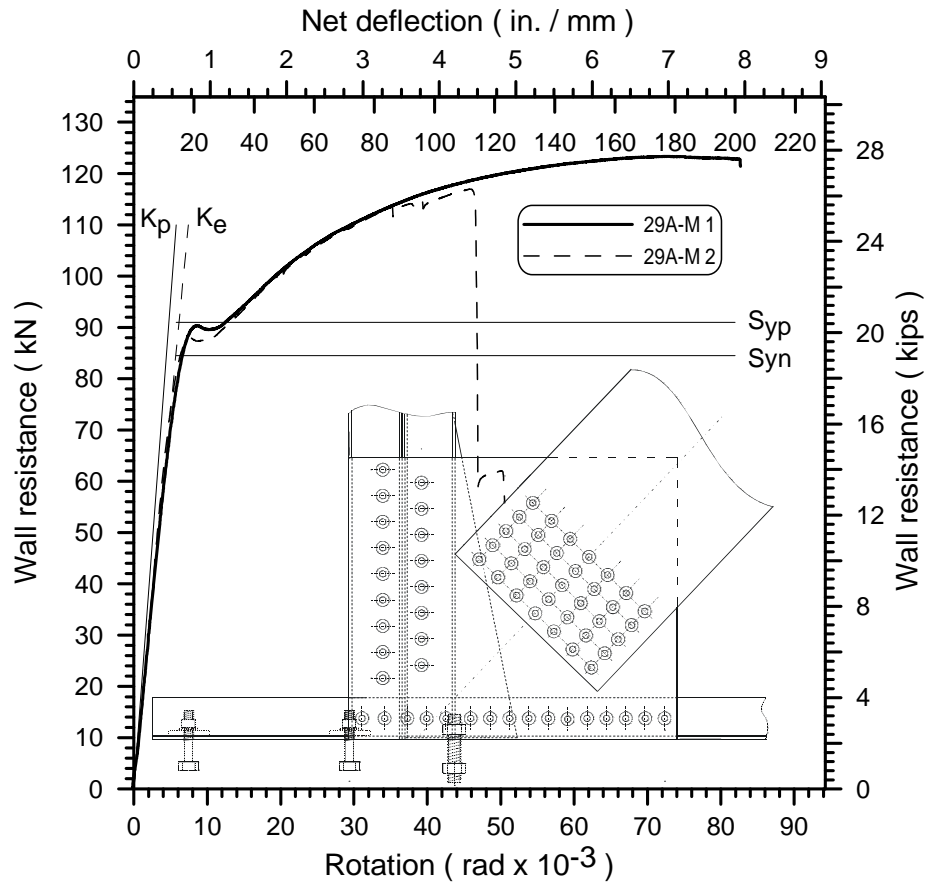

Figure A.10 Monotonic test results specimen 29A-M 1 and 29A-M 2

Table A.6 Monotonic test results specimen 29A-M 1 and 29A-M 2

Test Result	Specimen		29 A-M 1	29 A-M 2	Units
		S_{max}		123.37	116.96
	Δ_{max}		201.73	113.62	mm
	S_y		89.60	87.40	kN
	$S_{0.40}$		49.35	46.78	kN
	$\Delta_{S0.40}$		8.13	7.23	mm
	K_e		6.07	6.47	kN/mm
	Ductility μ		13.67	8.41	mm/mm
Prediction (Actual Dimensions)	S_{yp}		90.97	91.06	kN
	K_p		7.79	7.79	kN/mm
Prediction (Nominal Dimensions)	S_{yn}		84.51		kN
	K_n		7.66		kN/mm
Strain Gauge Results Specimen 29 A-M 1					
Gauge	SG1	SG2	SG3	SG4	SG5
Max Strain (mm/mm)	8673	12352	16223	NA	NA
Yielding Strain (mm/mm)	1737	1737	1737	NA	NA
Yielding Status	OK	OK	OK	NA	NA

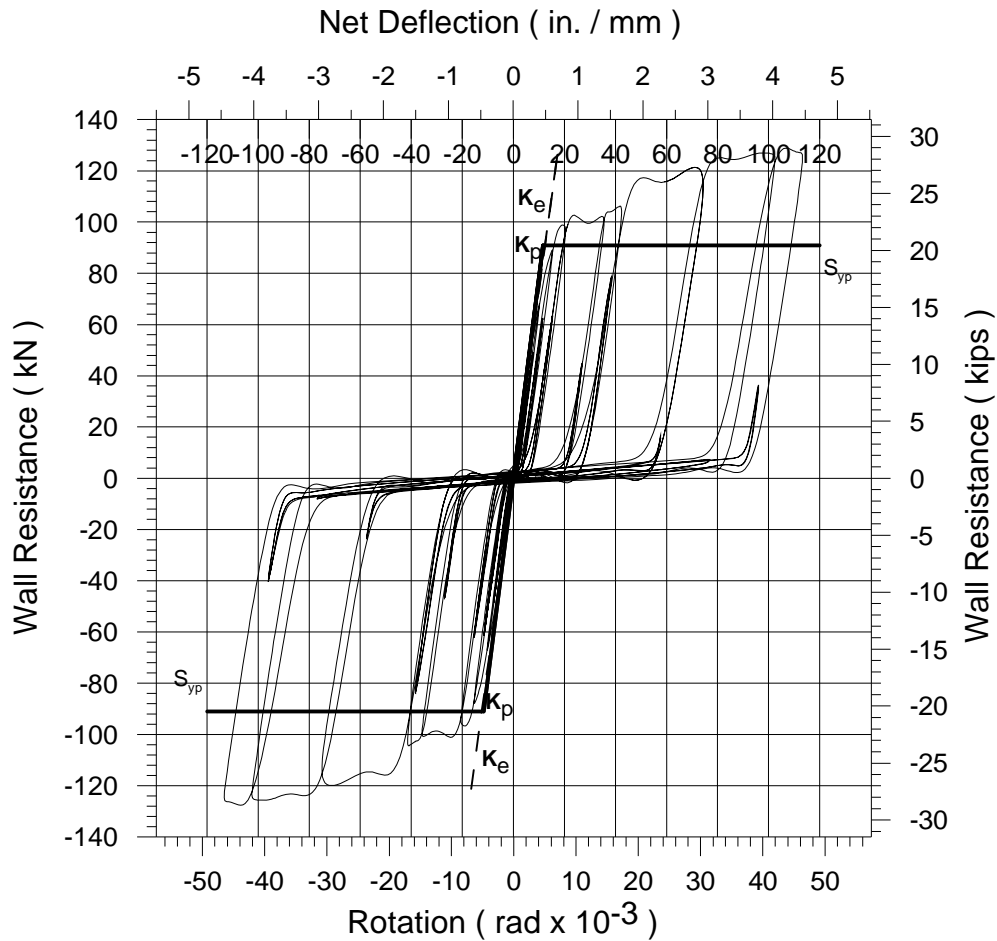

Figure A.11 Cyclic test results specimen 30A-C

Table A.7 Cyclic test results specimen 30A-C

Test Result	Parameters	Negative	Positive	Units		
	S_{max}	-127.59	128.85	kN		
Δ_{max}	-113.25	113.24	mm			
$S_{0.40}$	-51.04	51.54	kN			
$\Delta_{S0.40}$	-6.95	7.04	mm			
K_e	7.34	7.33	kN/mm			
Ductility μ	9.14	9.13	mm/mm			
Prediction (Actual Dimensions)	S_{yp}	-90.97	90.88	kN		
	K_p	7.79	7.79	kN/mm		
Prediction (Nominal Dimensions)	S_{yn}	84.51		kN		
	K_n	7.66		kN/mm		
Strain Gauge Results						
Gauge	SG1	SG2	SG3	SG4	SG5	SG6
Max Strain (mm/mm)	3047	13750	15894	16252	16140	15588
Yielding Strain (mm/mm)	1737	1737	1737	1737	1737	1737
Yielding Status	OK	OK	OK	OK	OK	OK

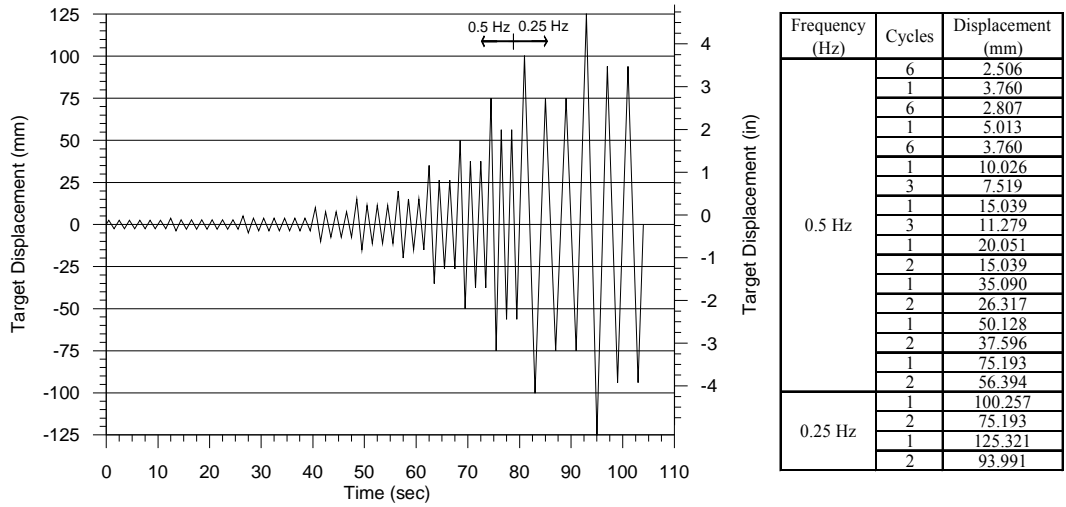

Figure A.12 Reversed cyclic CUREE test protocol for specimen 30A-C

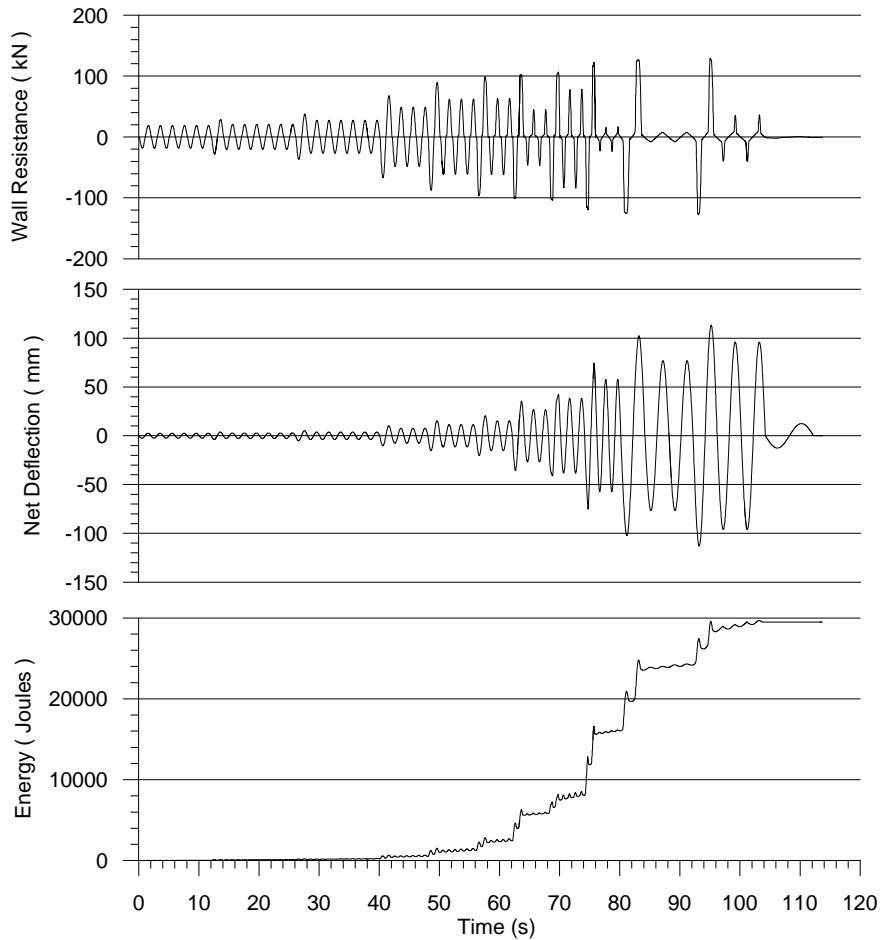

Figure A.13 Time history of specimen 30 A-C

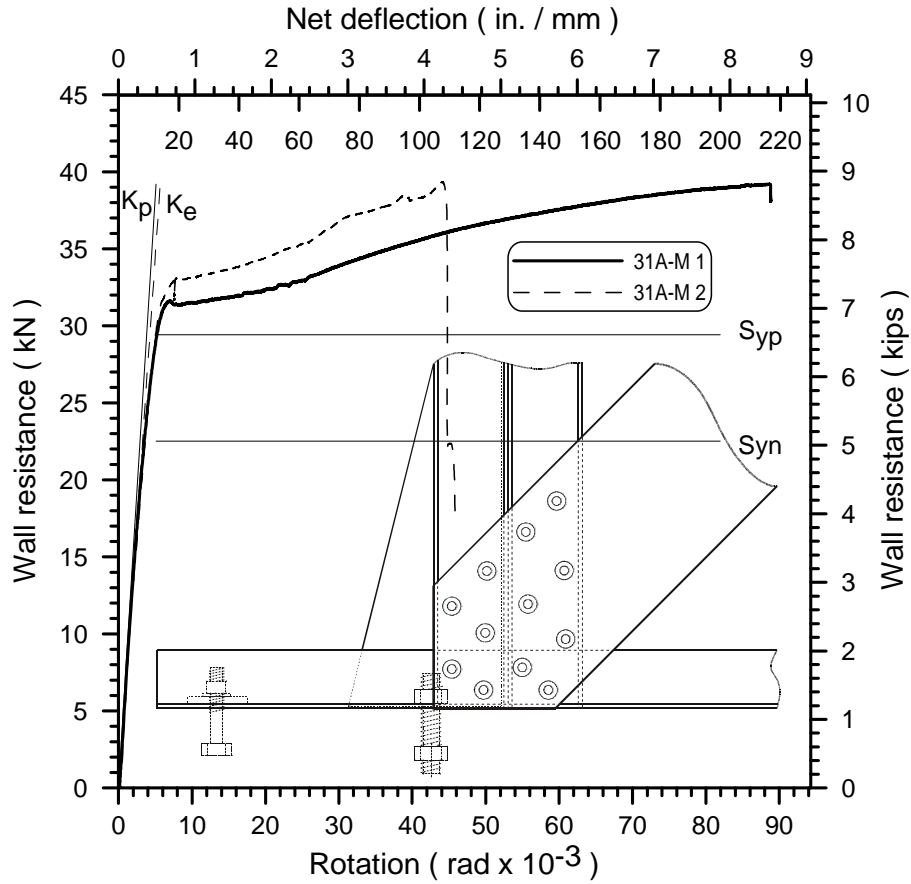

Figure A.14 Monotonic test results specimen 31A-M 1 and 31A-M 2

Table A.8 Monotonic test results specimen 31A-M 1 and 31A-M 2

Test Result	Specimen		31 A-M 1	31 A-M 2	Units
		S_{max}		39.20	39.35
	Δ_{max}		216.70	109.29	mm
	S_y		31.40	33.00	kN
	$S_{0.40}$		15.68	15.74	kN
	$\Delta_{S0.40}$		5.54	5.97	mm
	K_e		2.83	2.64	kN/mm
	Ductility μ		19.52	8.73	mm/mm
Prediction (Actual Dimensions)	S_{yp}		29.41	29.78	kN
	K_p		3.15	3.16	kN/mm
Prediction (Nominal Dimensions)	S_{yn}		22.51		kN
	K_n		3.12		kN/mm
Strain Gauge Results Specimen 31 A-M 1					
Gauge	SG1	SG2	SG3	SG4	SG5
Max Strain (mm/mm)	1388	1276	16306	16402	16123
Yielding Strain (mm/mm)	1456	1456	1456	1456	1456
Yielding Status	NO	NO	OK	OK	OK

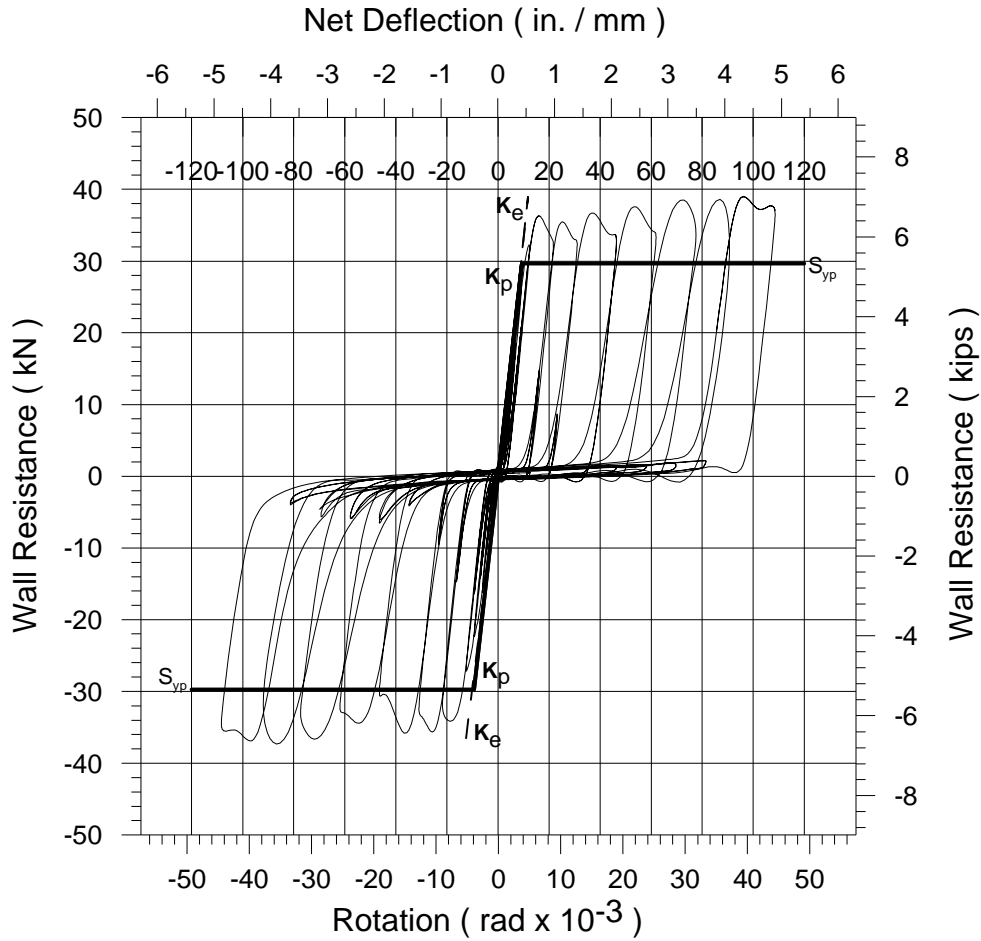

Figure A.15 Cyclic test results specimen 32A-C

Table A.9 Cyclic test results specimen 32A-C

Test Result	Parameters	Negative	Positive	Units		
	S_{max}	-37.30	38.97	kN		
Δ_{max}	-108.33	108.52	mm			
$S_{0.40}$	-14.92	15.59	kN			
$\Delta_{S0.40}$	-5.09	4.72	mm			
K_e	2.93	3.30	kN/mm			
Ductility μ	10.67	12.08	mm/mm			
Prediction (Actual Dimensions)	S_{yp}	-29.74	29.64	kN		
	K_p	3.16	3.16	kN/mm		
Prediction (Nominal Dimensions)	S_{yn}	22.51		kN		
	K_n	3.12		kN/mm		
Strain Gauge Results						
Gauge	SG1	SG2	SG3	SG4	SG5	SG6
Max Strain (mm/mm)	1271	14320	16320	2450	11626	16705
Yielding Strain (mm/mm)	1456	1456	1456	1456	1456	1456
Yielding Status	NO	OK	OK	OK	OK	OK

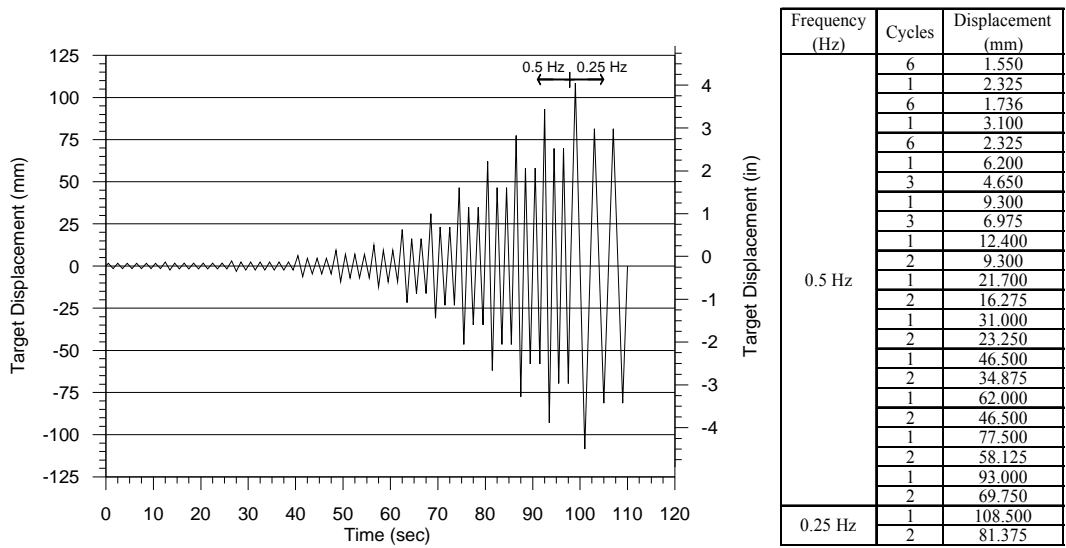

Figure A.16 Reversed cyclic CUREE test protocol for specimen 32 A-C

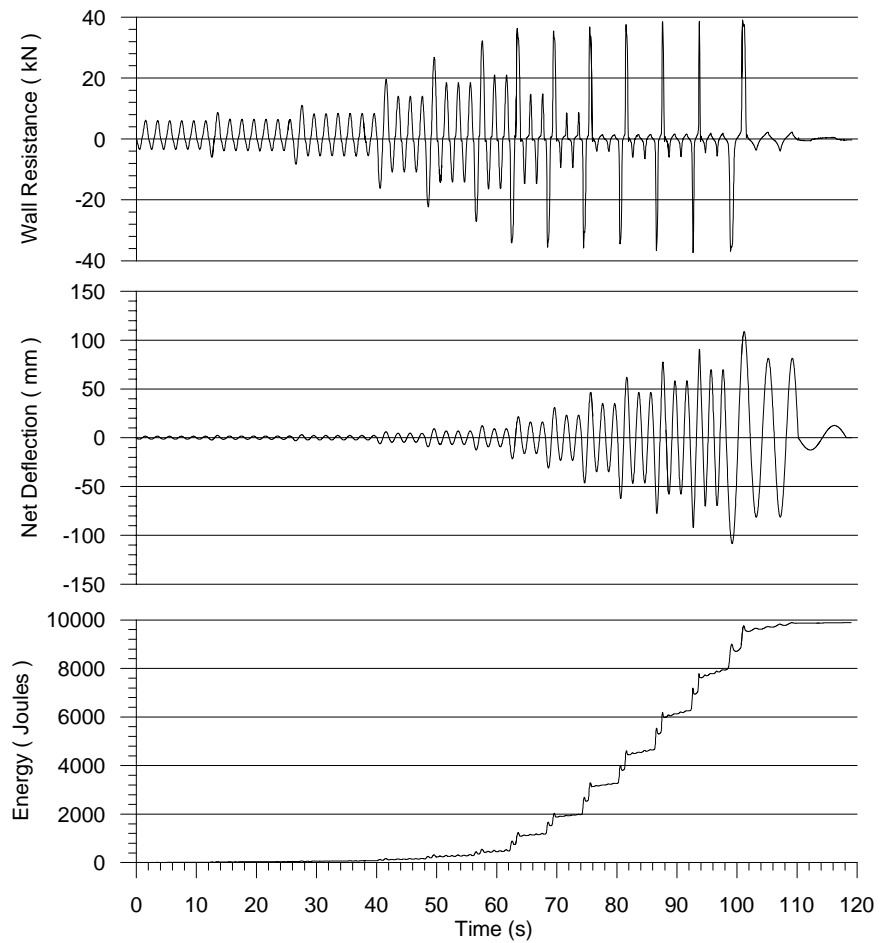

Figure A.17 Time history of specimen 32 A-C

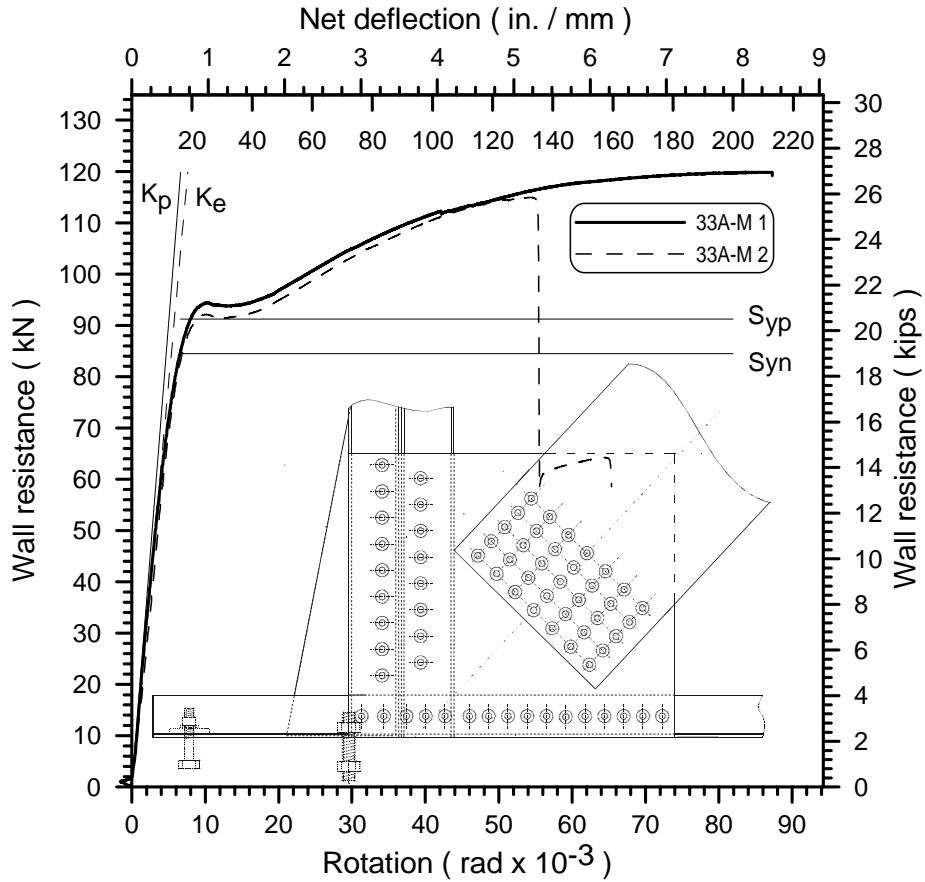

Figure A.18 Monotonic test results specimen 33A-M 1 and 33A-M 2

Table A.10 Monotonic test results specimen 33A-M 1 and 33A-M 2

Test Result	Specimen		33 A-M 1	33 A-M 2	Units
		S_{max}		119.86	114.97
	Δ_{max}		212.99	135.17	mm
	S_y		93.80	91.40	kN
	$S_{0.40}$		47.95	45.99	kN
	$\Delta_{S0.40}$		7.43	7.94	mm
	K_e		6.46	5.79	kN/mm
	Ductility μ		14.66	8.57	mm/mm
Prediction (Actual Dimensions)	S_{yp}		91.24	91.06	kN
	K_p		7.40	7.40	kN/mm
Prediction (Nominal Dimensions)	S_{yn}		84.51		kN
	K_n		7.26		kN/mm
Strain Gauge Results Specimen 33 A-M 1					
Gauge	SG1	SG2	SG3	SG4	SG5
Max Strain (mm/mm)	NA	NA	NA	7205	9833
Yielding Strain (mm/mm)	NA	NA	NA	1737	1737
Yielding Status	NA	NA	NA	OK	OK

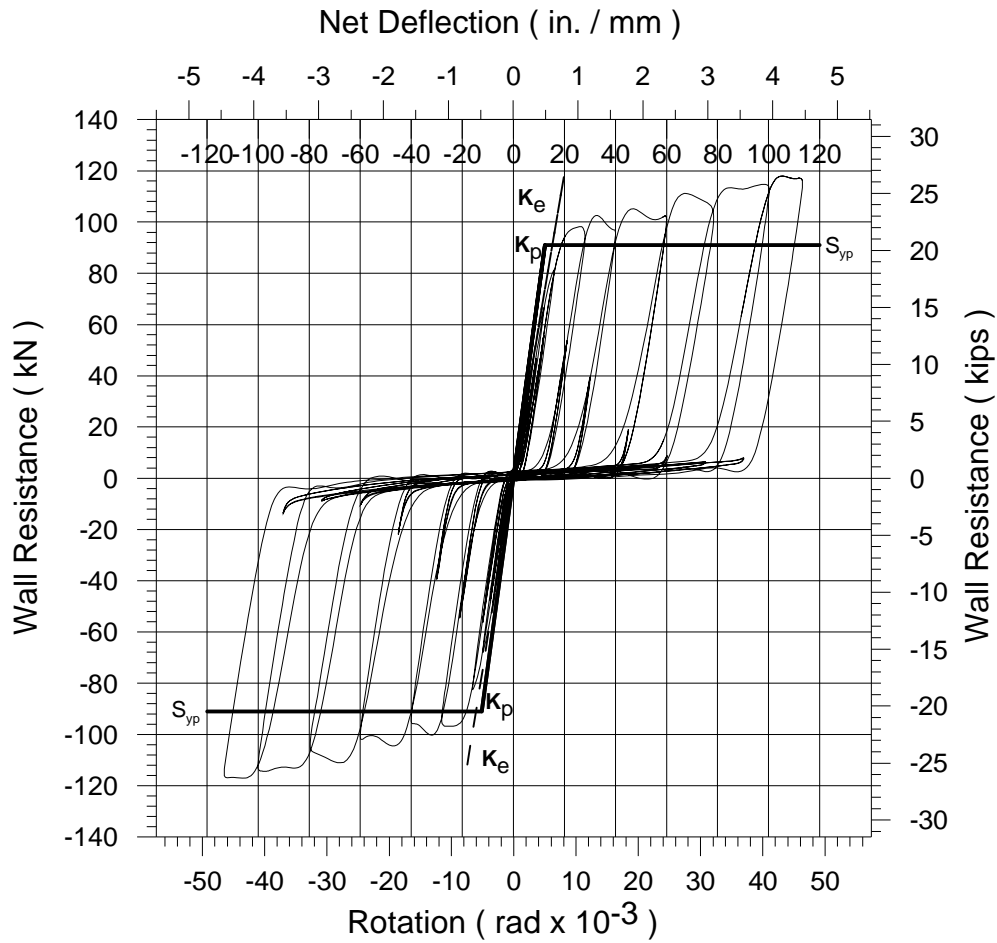

Figure A.19 Cyclic test results specimen 34A-C

Table A.11 Cyclic test results specimen 34A-C

Test Result	Parameters	Negative	Positive	Units		
	S_{max}	-117.09	117.97	kN		
Δ_{max}	-113.26	113.24	mm			
$S_{0.40}$	-46.83	47.19	kN			
$\Delta_{S0.40}$	-7.56	7.92	mm			
K_e	6.20	5.96	kN/mm			
Ductility μ	7.71	7.41	mm/mm			
Prediction (Actual Dimensions)	S_{yp}	-91.06	91.06	kN		
	K_p	7.40	7.40	kN/mm		
Prediction (Nominal Dimensions)	S_{yn}	84.51		kN		
	K_n	7.26		kN/mm		
Strain Gauge Results						
Gauge	SG1	SG2	SG3	SG4	SG5	SG6
Max Strain (mm/mm)	2286	16262	16371	2105	15803	16718
Yielding Strain (mm/mm)	1737	1737	1737	1737	1737	1737
Yielding Status	OK	OK	OK	OK	OK	OK

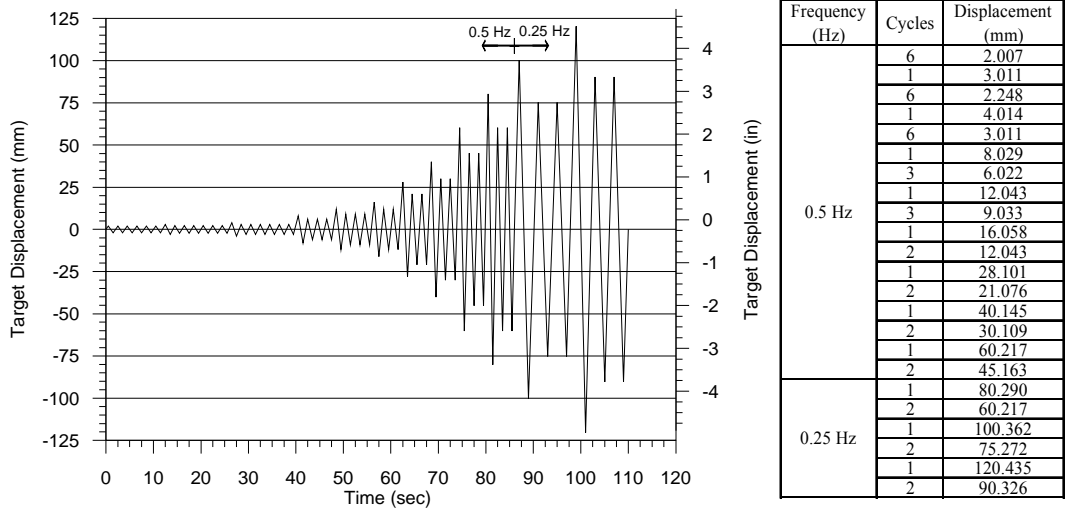

Figure A.20 Reversed cyclic CUREE test protocol for specimen 34A-C

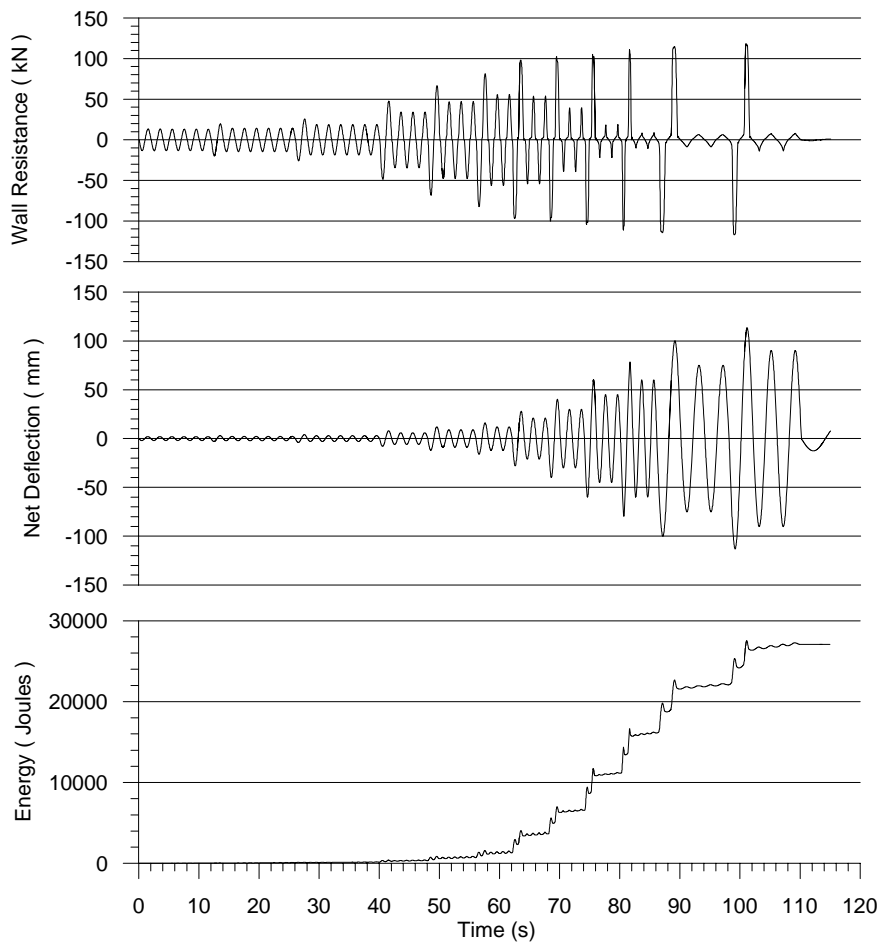

Figure A.21 Time history of specimen 34A-C

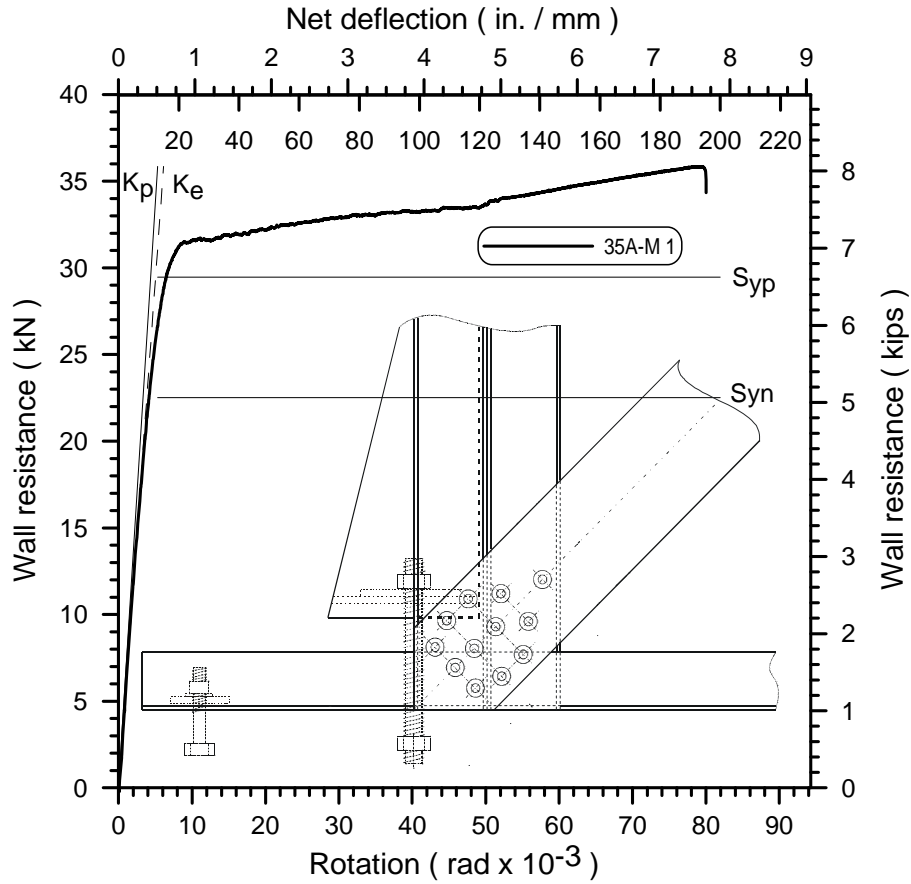

Figure A.22 Monotonic test results specimen 35A-M 1

Table A.12 Monotonic test results specimen 35A-M 1

Test Result	Specimen	35 A-M 1	35 A-M 2	Units	
		S_{max}	35.85	NA	kN
	Δ_{max}	196.04	NA	mm	
	S_v	31.60	NA	kN	
	$S_{0.40}$	14.34	NA	kN	
	$\Delta_{S0.40}$	5.98	NA	mm	
	K_e	2.40	NA	kN/mm	
	Ductility μ	14.89	NA	mm/mm	
Prediction (Actual Dimensions)	S_{yp}	29.46	NA	kN	
	K_p	2.78	NA	kN/mm	
Prediction (Nominal Dimensions)	S_{yn}	22.51	NA	kN	
	K_n	2.75	NA	kN/mm	
Strain Gauge Results Specimen 35 A-M 1					
Gauge	SG1	SG2	SG3	SG4	SG5
Max Strain (mm/mm)	16009	16709	16060	NA	NA
Yielding Strain (mm/mm)	1456	1456	1456	NA	NA
Yielding Status	OK	OK	OK	NA	NA

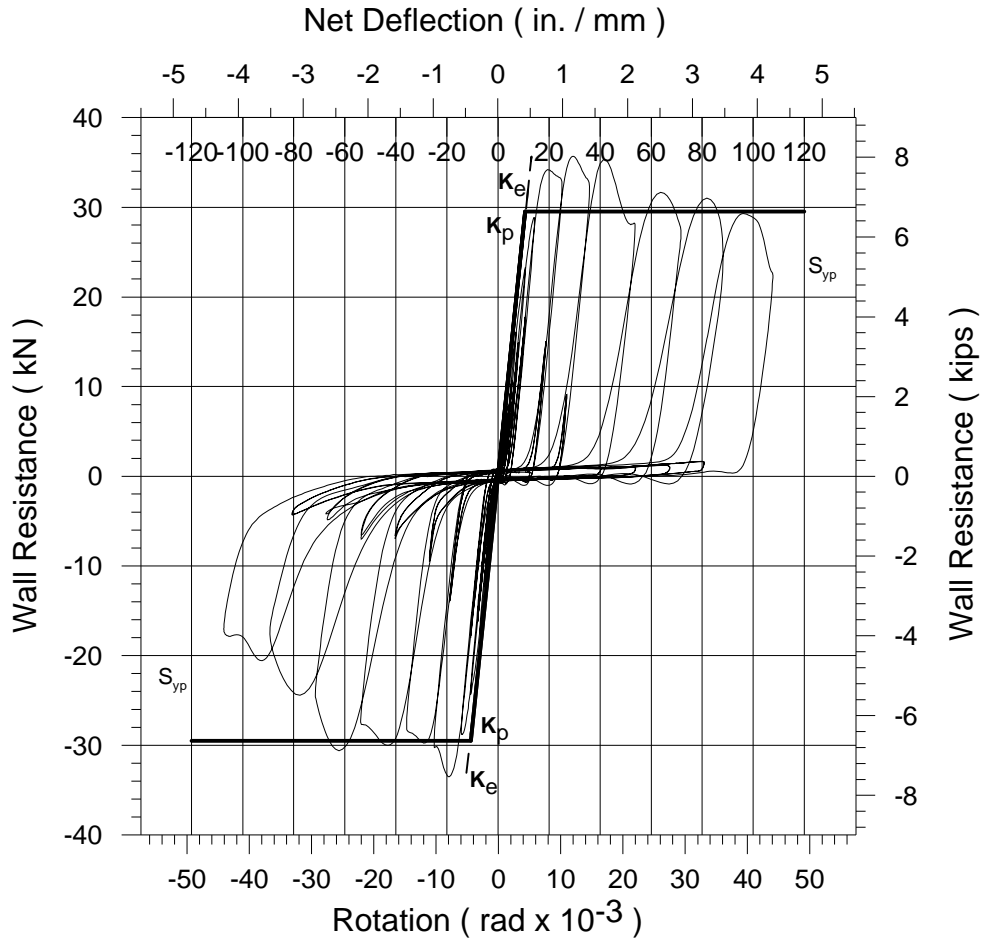

Figure A.23 Cyclic test results specimen 36A-C

Table A.13 Cyclic test results specimen 36A-C

Test Result	Parameters	Negative	Positive	Units		
	S_{max}	-33.51	35.68	kN		
	Δ_{max}	-107.39	107.66	mm		
	$S_{0.40}$	-13.40	14.27	kN		
	$\Delta_{S0.40}$	-4.99	5.26	mm		
	K_e	2.69	2.72	kN/mm		
	Ductility μ	9.77	9.91	mm/mm		
Prediction (Actual Dimensions)	S_{yp}	-29.51	29.51	kN		
	K_p	2.78	2.78	kN/mm		
Prediction (Nominal Dimensions)	S_{yn}	22.51		kN		
	K_n	2.75		kN/mm		
Strain Gauge Results						
Gauge	SG1	SG2	SG3	SG4	SG5	SG6
Max Strain (mm/mm)	16096	16230	16379	2061	2420	2672
Yielding Strain (mm/mm)	1456	1456	1456	1456	1456	1456
Yielding Status	OK	OK	OK	OK	OK	OK

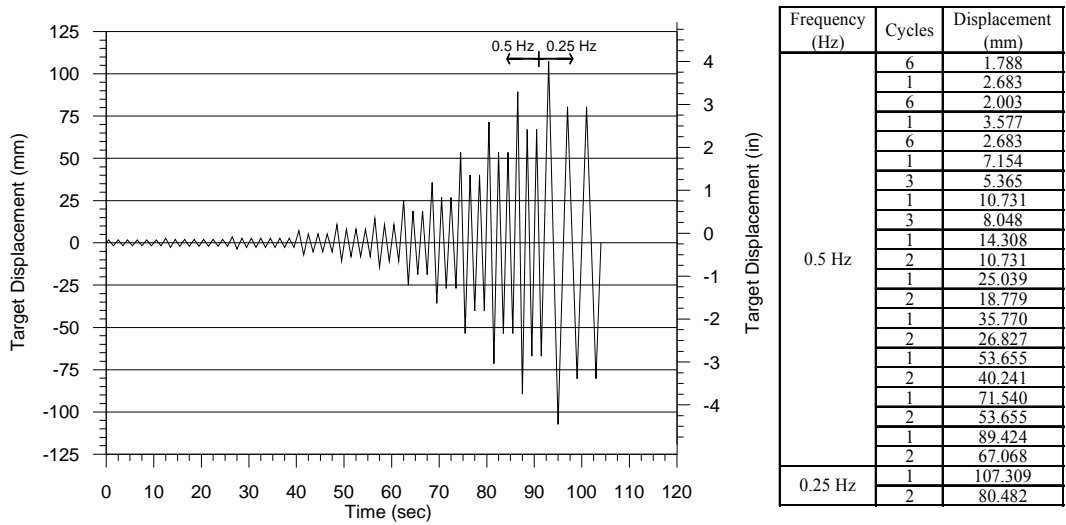

Figure A.24 Reversed cyclic CUREE test protocol for specimen 36 A-C

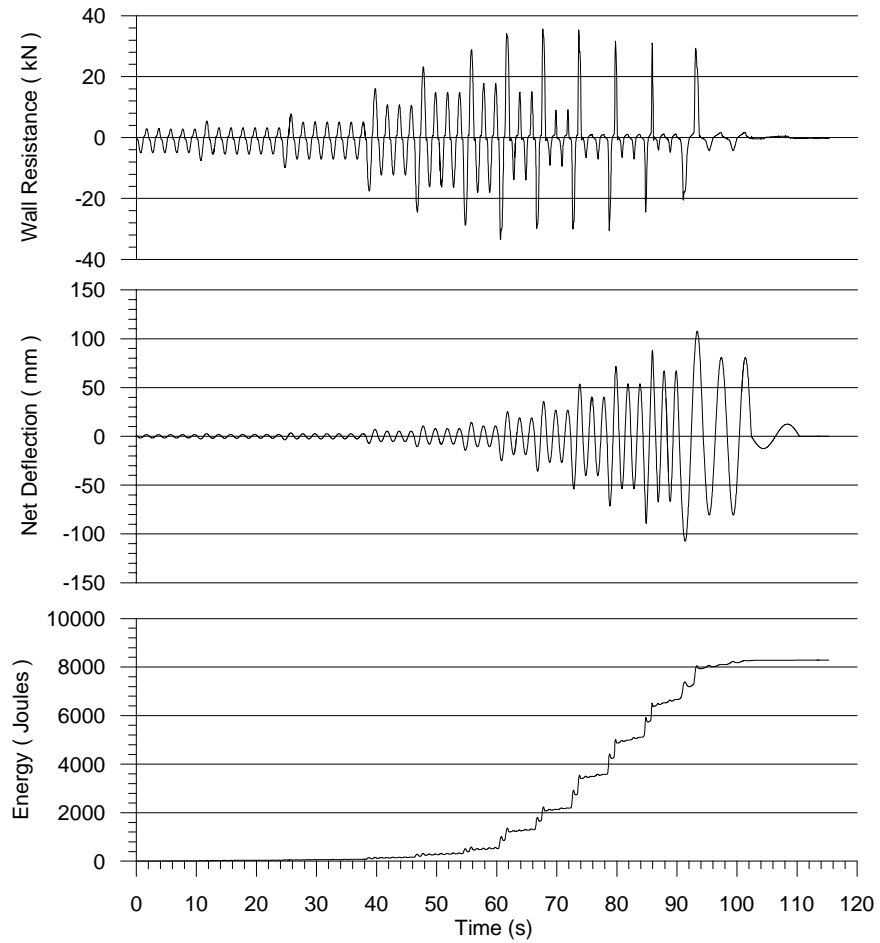

Figure A.25 Time history of specimen 36 A-C

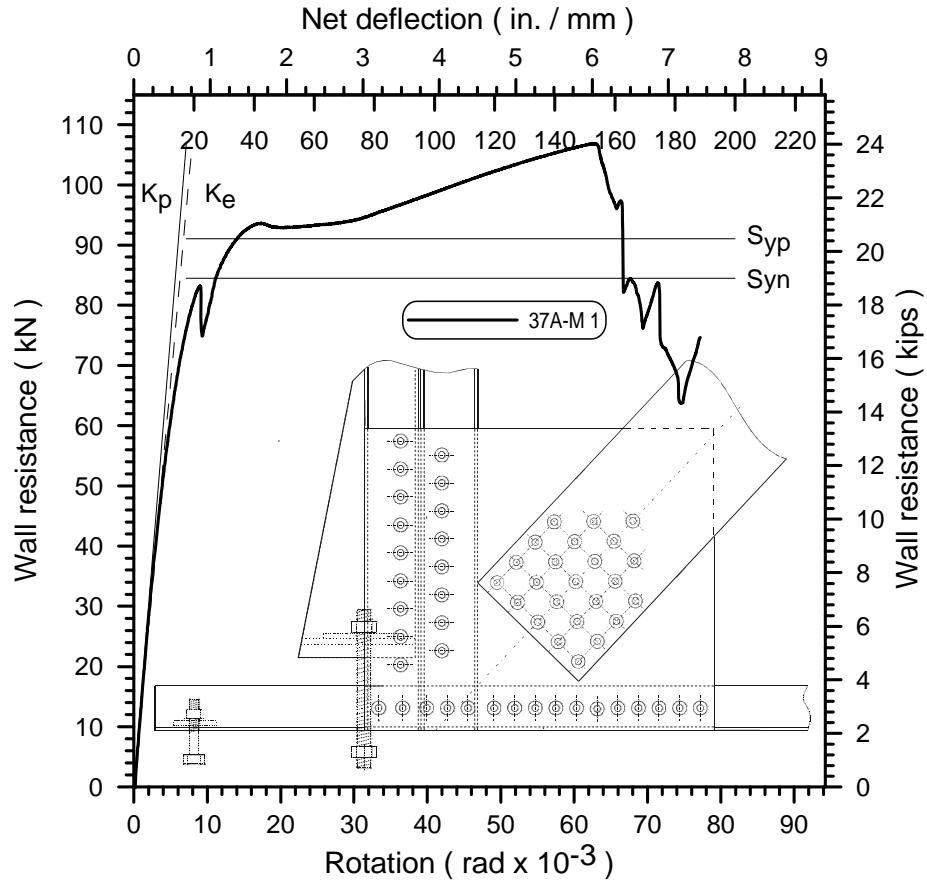

Figure A.26 Monotonic test results specimen 37A-M 1

Table A.14 Monotonic test results specimen 37A-M 1

Test Result	Specimen		37 A-M 1	37 A-M 2	Units
		S_{max}		106.86	NA
	Δ_{max}		154.60	NA	mm
	S_y		92.90	NA	kN
	$S_{0.40}$		42.74	NA	kN
	$\Delta_{S0.40}$		7.74	NA	mm
	K_e		5.52	NA	kN/mm
	Ductility μ		9.19	NA	mm/mm
Prediction (Actual Dimensions)	S_{yp}		91.06	NA	kN
	K_p		6.13	NA	kN/mm
Prediction (Nominal Dimensions)	S_{yn}		84.51	NA	kN
	K_n		6.02	NA	kN/mm
Strain Gauge Results Specimen 37 A-M 1					
Gauge	SG1	SG2	SG3	SG4	SG5
Max Strain (mm/mm)	16158	16243	16319	9000	130767
Yielding Strain (mm/mm)	1737	1737	1737	1737	1737
Yielding Status	OK	OK	OK	OK	OK

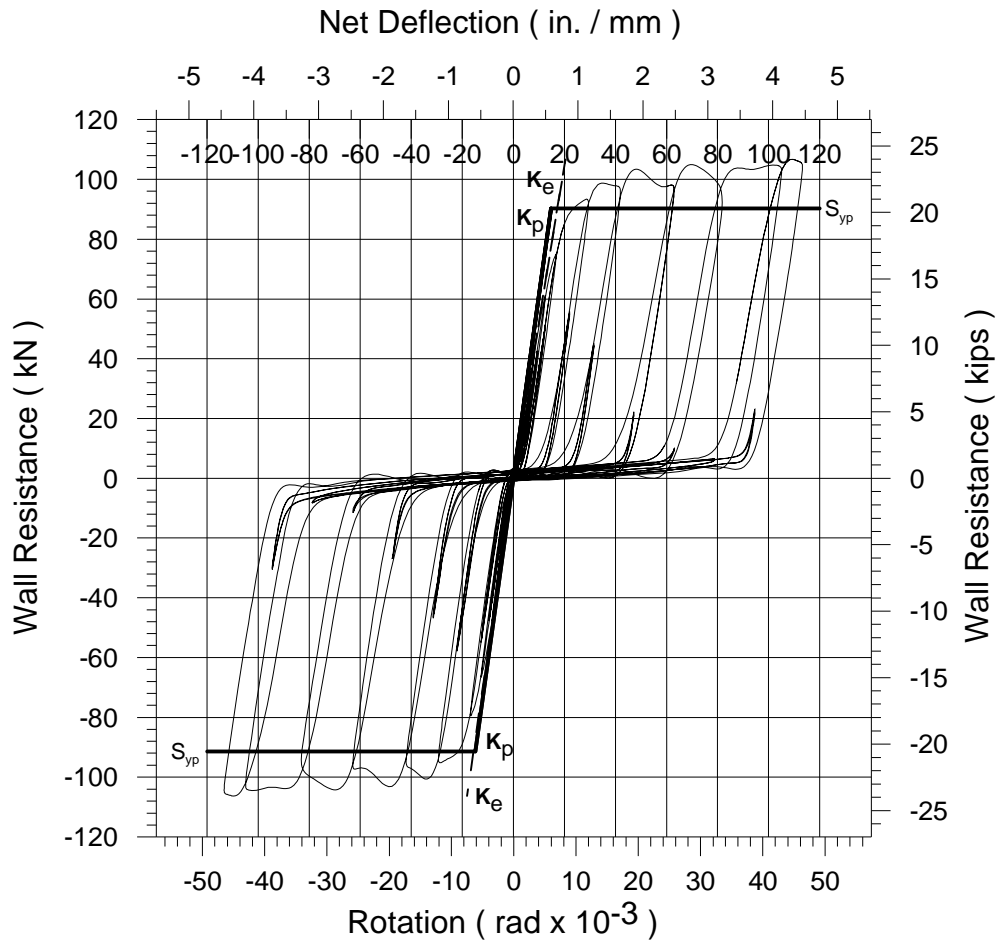

Figure A.27 Cyclic test results specimen 38A-C

Table A.15 Cyclic test results specimen 38A-C

Test Result	Parameters	Negative	Positive	Units		
	S _{max}	-106.28	106.70	kN		
Δ _{max}	-113.27	113.24	mm			
S _{0.40}	-42.51	42.68	kN			
Δ _{S0.40}	-7.27	8.14	mm			
K _e	5.85	5.24	kN/mm			
Ductility μ	7.25	6.57	mm/mm			
Prediction (Actual Dimensions)	S _{yp}	-91.42	90.25	kN		
	K _p	6.15	6.11	kN/mm		
Prediction (Nominal Dimensions)	S _{yn}	84.51		kN		
	K _n	6.02		kN/mm		
Strain Gauge Results						
Gauge	SG1	SG2	SG3	SG4	SG5	SG6
Max Strain (mm/mm)	16100	15164	16350	15092	16099	16709
Yielding Strain (mm/mm)	1737	1737	1737	1737	1737	1737
Yielding Status	OK	OK	OK	OK	OK	OK

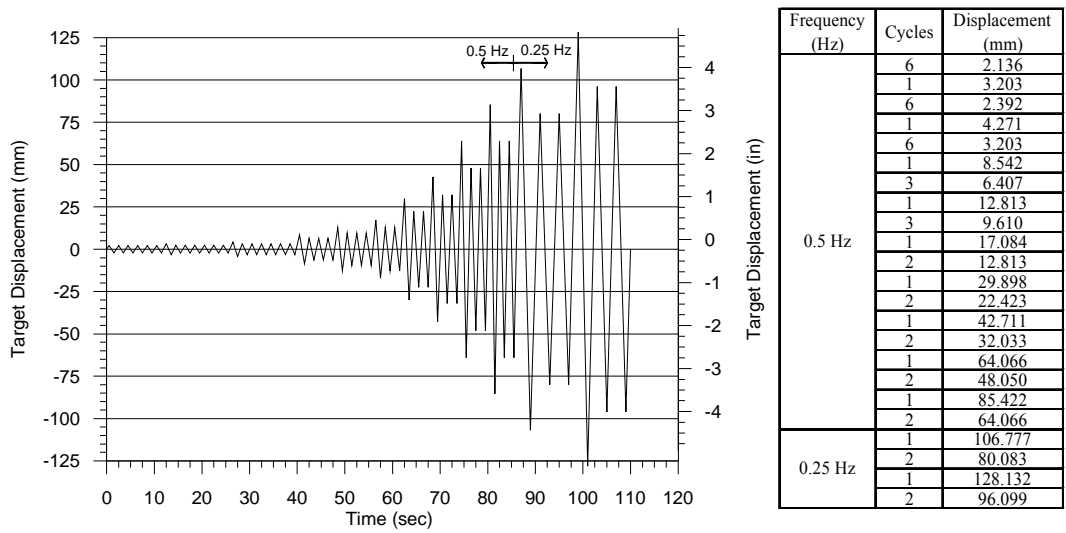

Figure A.28 Reversed cyclic CUREE test protocol for specimen 38 A-C

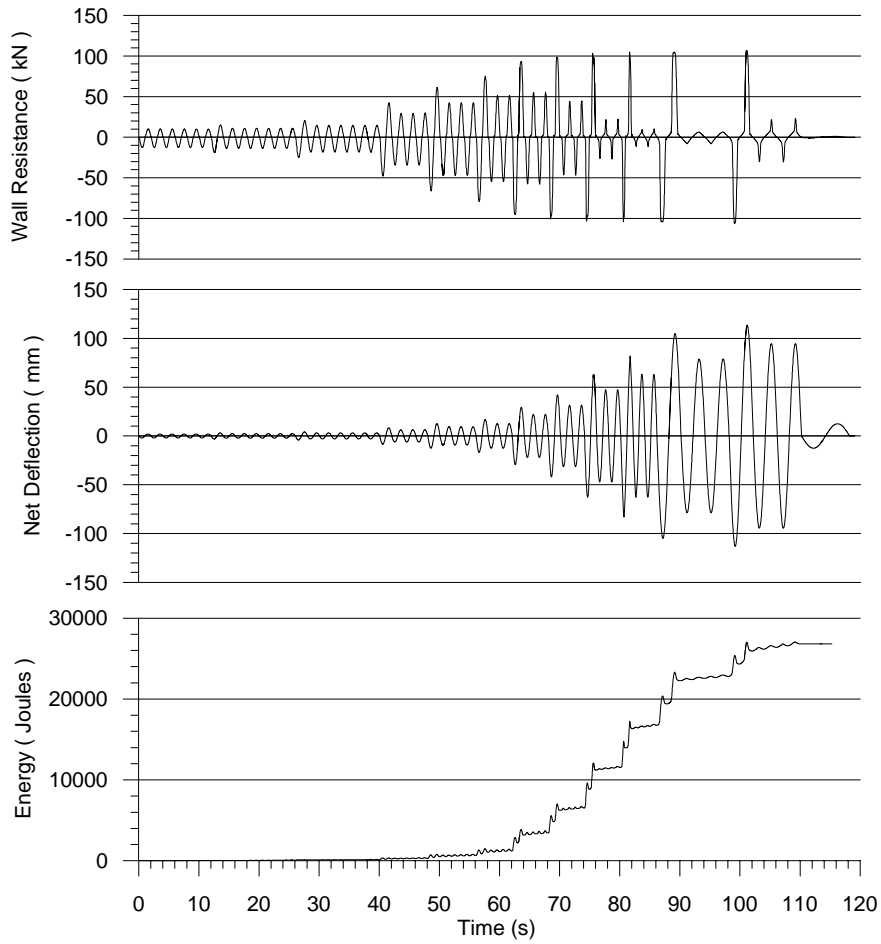

Figure A.29 Time history of specimen 38 A-C

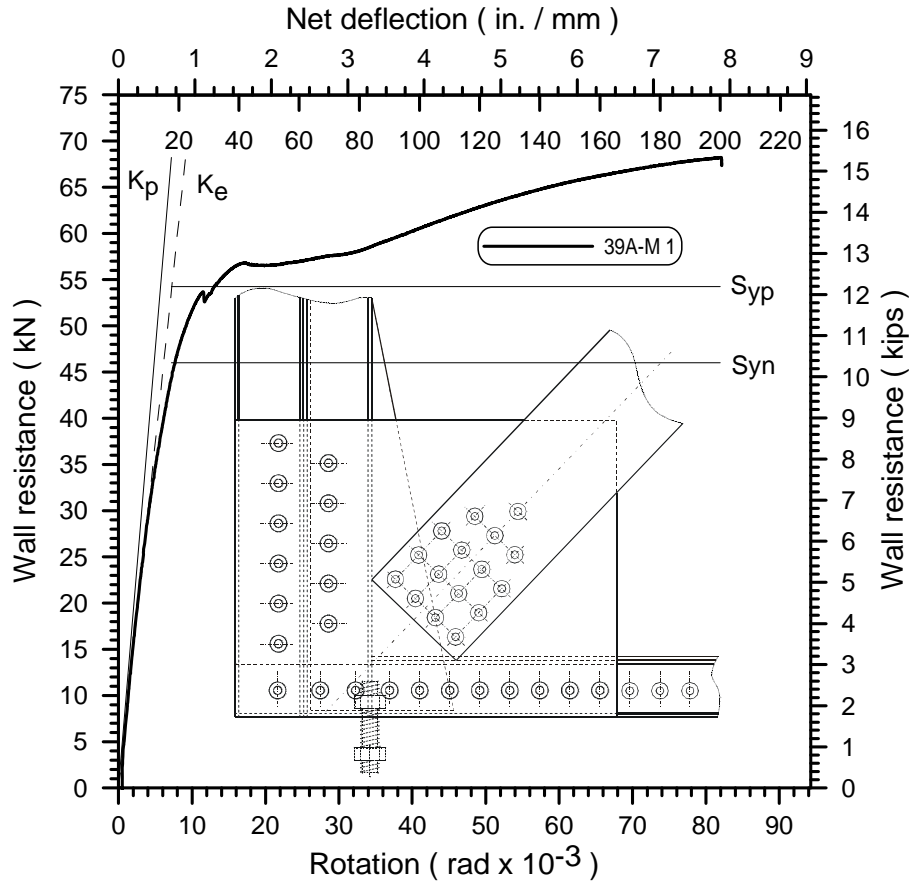

Figure A.30 Monotonic test results specimen 39A-M 1

Table A.16 Monotonic test results specimen 39A-M 1

Test Result	Specimen		39 A-M 1	39 A-M 2	Units
		S_{max}		68.21	NA
	Δ_{max}		200.45	NA	mm
	S_y		56.50	NA	kN
	$S_{0.40}$		27.28	NA	kN
	$\Delta_{S0.40}$		8.91	NA	mm
	K_e		3.06	NA	kN/mm
	Ductility μ		10.86	NA	mm/mm
Prediction (Actual Dimensions)	S_{yp}		54.25	NA	kN
	K_p		3.90	NA	kN/mm
Prediction (Nominal Dimensions)	S_{yn}		45.98	NA	kN
	K_n		3.81	NA	kN/mm
Strain Gauge Results Specimen 39 A-M 1					
Gauge	SG1	SG2	SG3	SG4	SG5
Max Strain (mm/mm)	16001	16088	16185	NA	NA
Yielding Strain (mm/mm)	1906	1906	1906	NA	NA
Yielding Status	OK	OK	OK	NA	NA

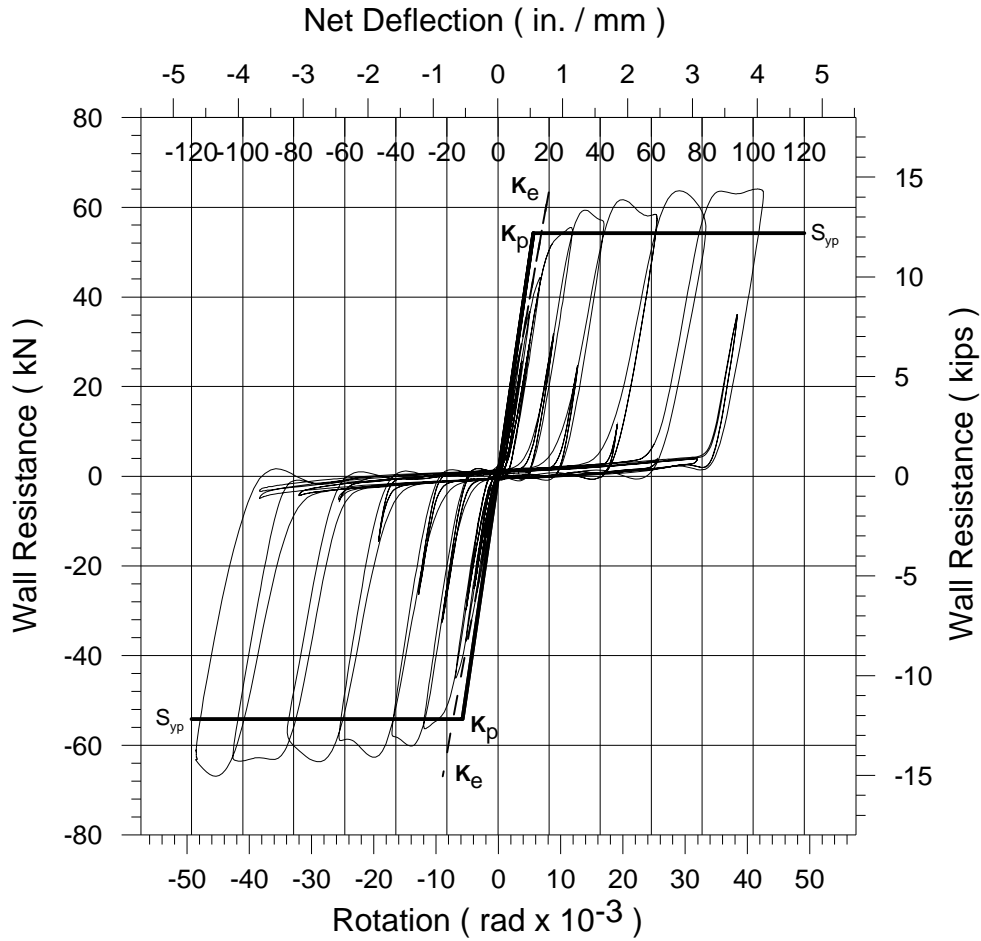

Figure A.31 Cyclic test results specimen 40A-C

Table A.17 Cyclic test results specimen 40A-C

Test Result	Parameters	Negative	Positive	Units		
	S_{max}	-66.87	64.09	kN		
Δ_{max}	-118.40	103.99	mm			
$S_{0.40}$	-26.75	25.64	kN			
$\Delta_{S0.40}$	-8.67	8.03	mm			
K_e	3.09	3.19	kN/mm			
Ductility μ	6.74	6.12	mm/mm			
Prediction (Actual Dimensions)	S_{yp}	-54.17	54.25	kN		
	K_p	3.89	3.90	kN/mm		
Prediction (Nominal Dimensions)	S_{yn}	45.98		kN		
	K_n	3.81		kN/mm		
Strain Gauge Results						
Gauge	SG1	SG2	SG3	SG4	SG5	SG6
Max Strain (mm/mm)	16142	16294	16270	16527	16345	15458
Yielding Strain (mm/mm)	1906	1906	1906	1906	1906	1906
Yielding Status	OK	OK	OK	OK	OK	OK

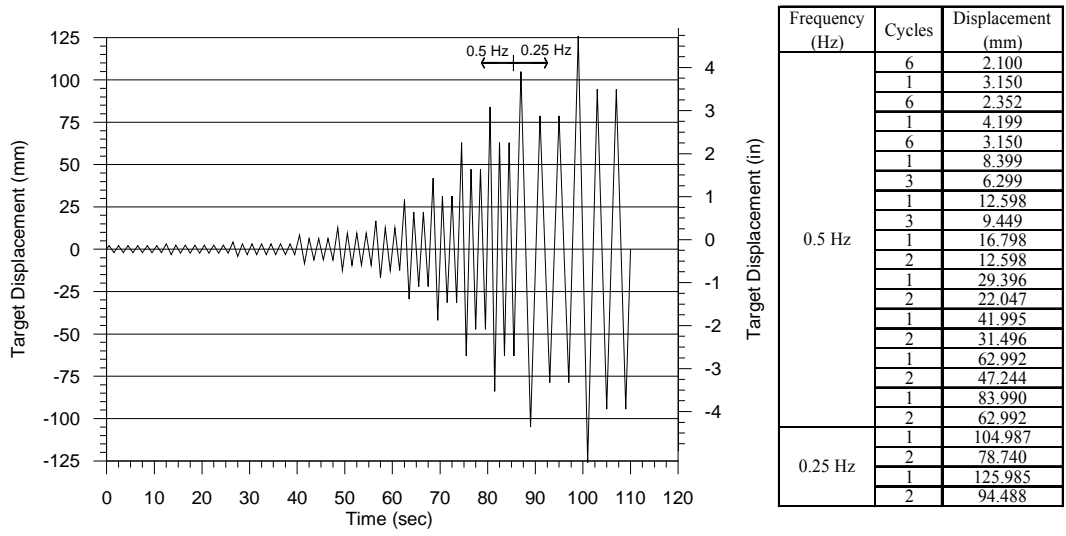

Figure A.32 Reversed cyclic CUREE test protocol for specimen 40 A-C

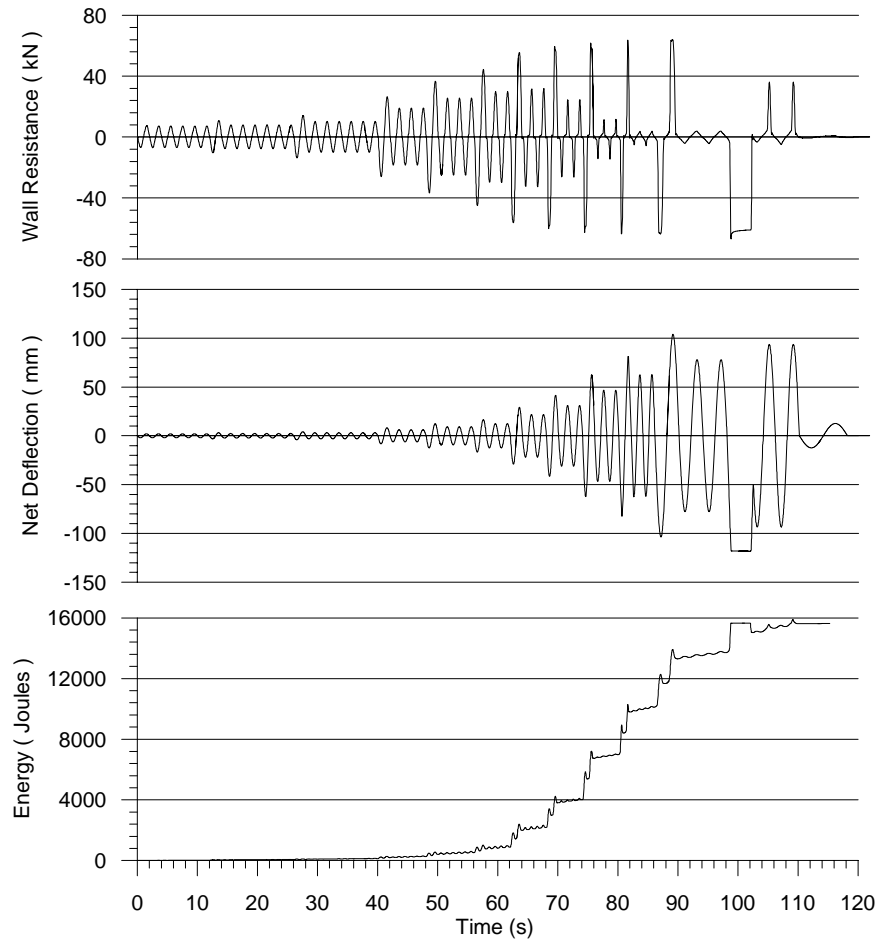

Figure A.33 Time history of specimen 40 A-C

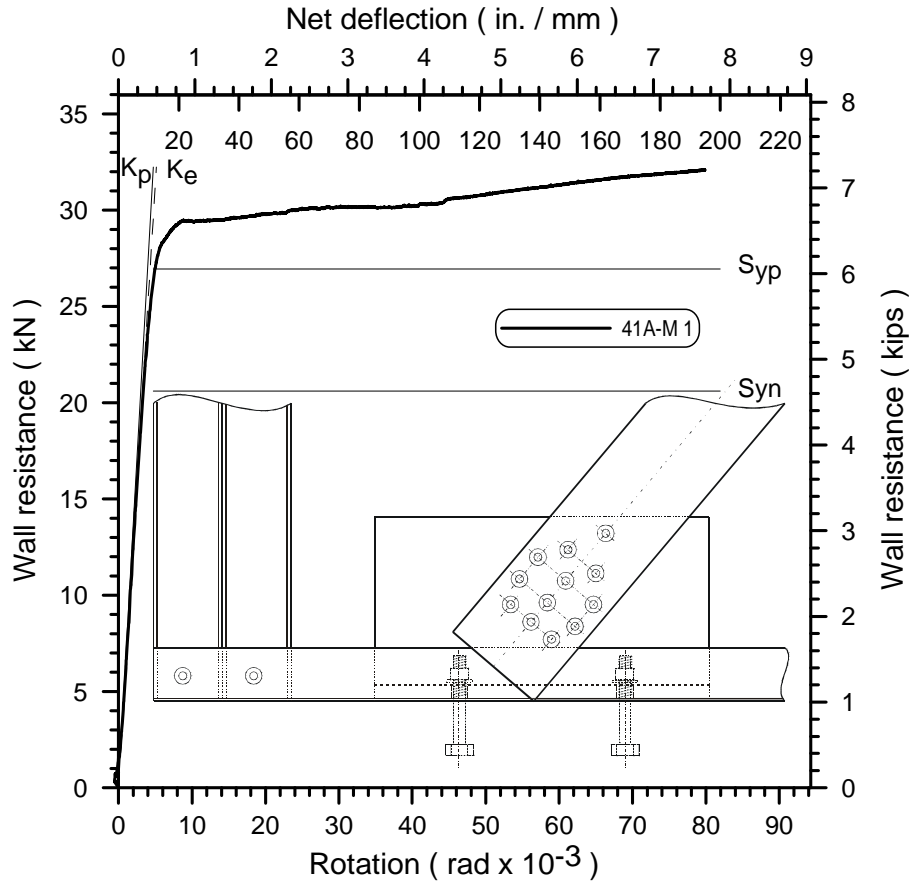

Figure A.34 Monotonic test results specimen 41A-M 1

Table A.18 Monotonic test results specimen 41A-M 1

Test Result	Specimen		41 A-M 1	41 A-M 2	Units
		S_{max}		32.23	NA
	Δ_{max}		203.64	NA	mm
	S_y		29.40	NA	kN
	$S_{0.40}$		12.89	NA	kN
	$\Delta_{S0.40}$		5.01	NA	mm
	K_e		2.57	NA	kN/mm
	Ductility μ		17.82	NA	mm/mm
Prediction (Actual Dimensions)	S_{yp}		26.95	NA	kN
	K_p		2.79	NA	kN/mm
Prediction (Nominal Dimensions)	S_{yn}		20.59	NA	kN
	K_n		2.76	NA	kN/mm
Strain Gauge Results Specimen 41 A-M 1					
Gauge	SG1	SG2	SG3	SG4	SG5
Max Strain (mm/mm)	16003	16062	16213	NA	NA
Yielding Strain (mm/mm)	1456	1456	1456	NA	NA
Yielding Status	OK	OK	OK	NA	NA

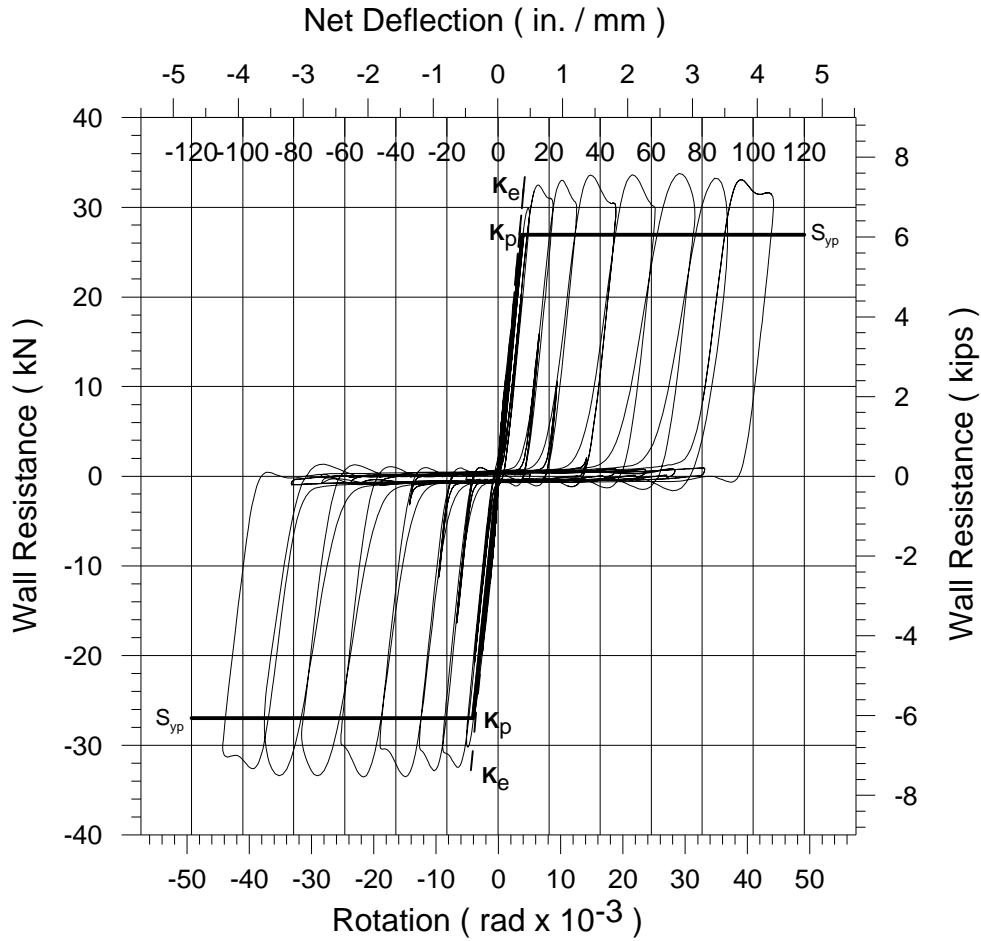

Figure A.35 Cyclic test results specimen 42A-C

Table A.19 Cyclic test results specimen 42A-C

Test Result	Parameters	Negative	Positive	Units		
	S_{max}	-33.54	33.76	kN		
Δ_{max}	-107.72	107.94	mm			
$S_{0.40}$	-13.42	13.50	kN			
$\Delta_{S0.40}$	-4.35	4.23	mm			
K_e	3.09	3.19	kN/mm			
Ductility μ	12.34	12.78	mm/mm			
Prediction (Actual Dimensions)	S_{yp}	-26.95	26.95	kN		
	K_p	2.79	2.79	kN/mm		
Prediction (Nominal Dimensions)	S_{vn}	20.59		kN		
	K_n	2.76		kN/mm		
Strain Gauge Results						
Gauge	SG1	SG2	SG3	SG4	SG5	SG6
Max Strain (mm/mm)	15205	15993	12965	16384	15969	16518
Yielding Strain (mm/mm)	1456	1456	1456	1456	1456	1456
Yielding Status	OK	OK	OK	OK	OK	OK

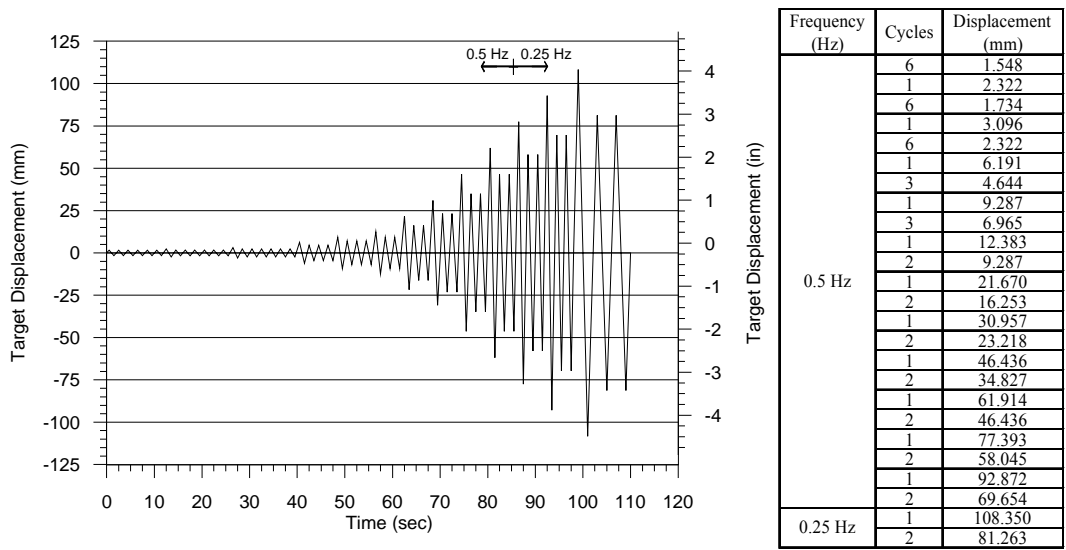

Figure A.36 Reversed cyclic CUREE test protocol for specimen 42 A-C

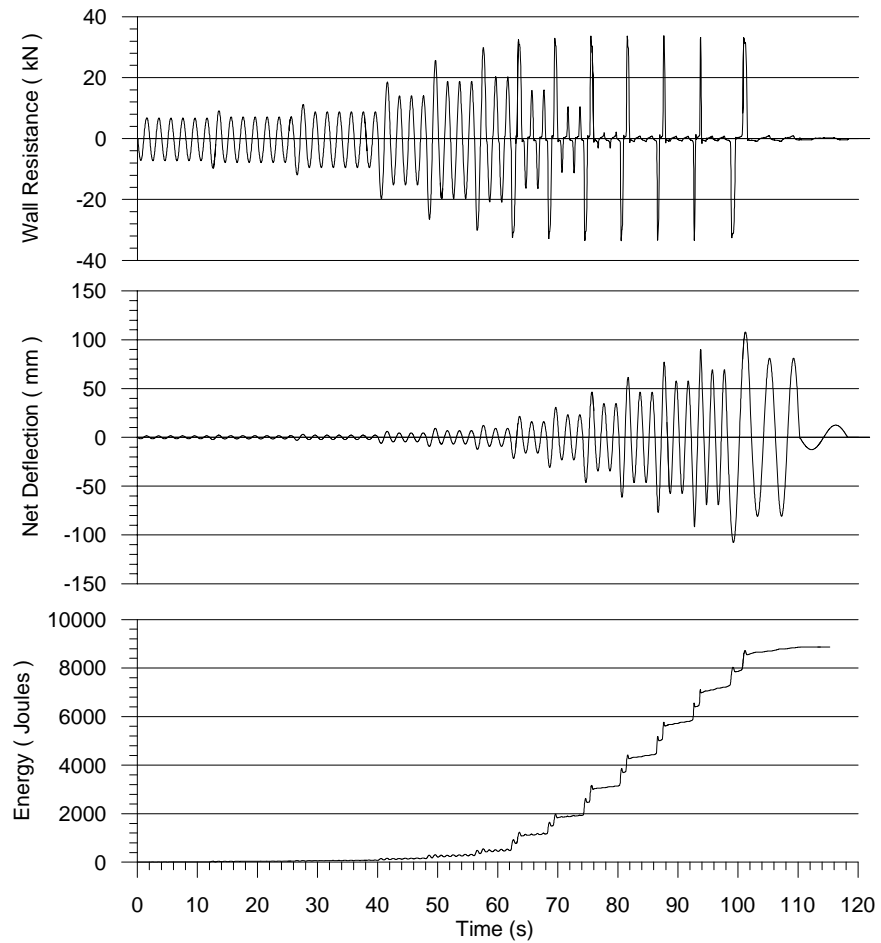

Figure A.37 Time history of specimen 42 A-C

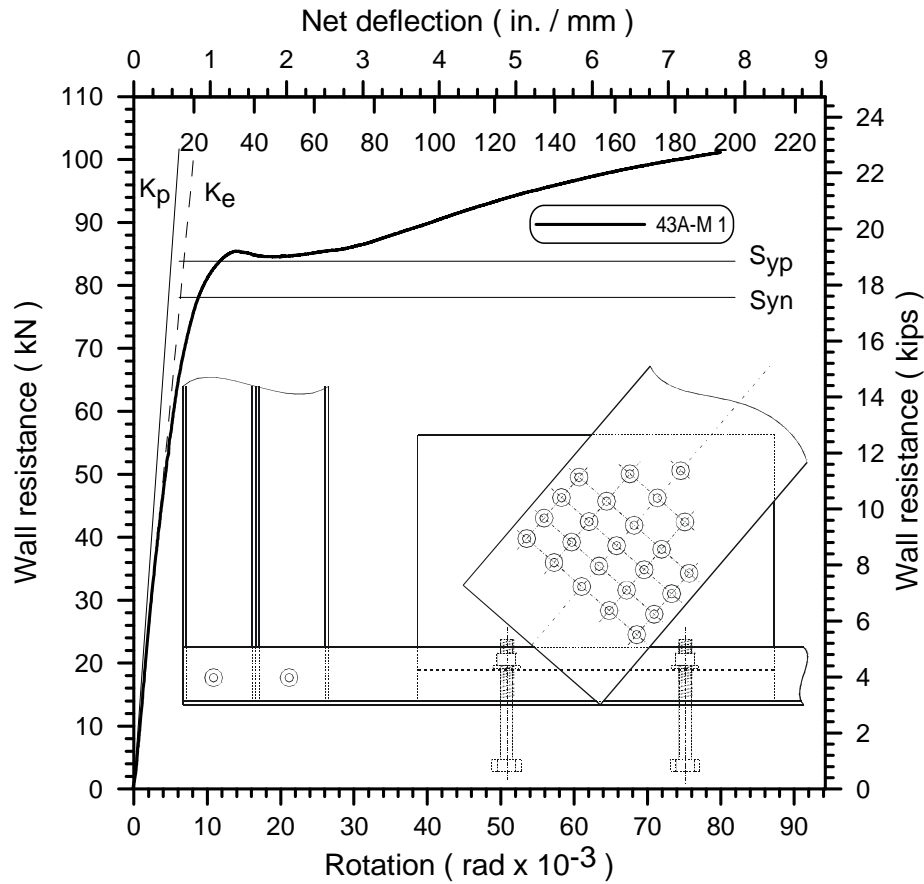

Figure A.38 Monotonic test results specimen 43A-M 1

Table A.20 Monotonic test results specimen 43A-M 1

Test Result	Specimen		43 A-M 1	43 A-M 2	Units
		S_{max}		101.67	NA
	Δ_{max}		201.81	NA	mm
	S_y		84.60	NA	kN
	$S_{0.40}$		40.67	NA	kN
	$\Delta_{S0.40}$		8.05	NA	mm
	K_e		5.05	NA	kN/mm
	Ductility μ		12.05	NA	mm/mm
Prediction (Actual Dimensions)	S_{yp}		83.81	NA	kN
	K_p		6.79	NA	kN/mm
Prediction (Nominal Dimensions)	S_{yn}		78.10	NA	kN
	K_n		6.65	NA	kN/mm
Strain Gauge Results Specimen 43 A-M 1					
Gauge	SG1	SG2	SG3	SG4	SG5
Max Strain (mm/mm)	NA	NA	NA	NA	NA
Yielding Strain (mm/mm)	NA	NA	NA	NA	NA
Yielding Status	NA	NA	NA	NA	NA

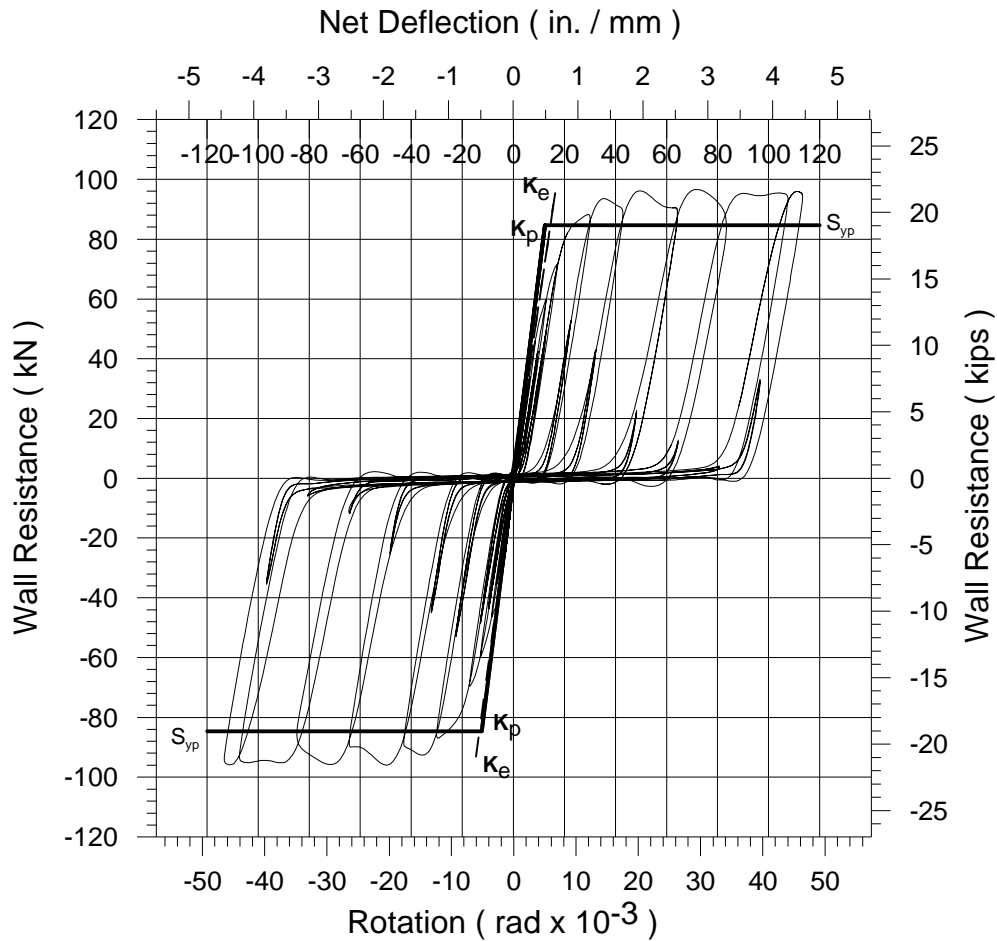

Figure A.39 Cyclic test results specimen 44A-C

Table A.21 Cyclic test results specimen 44A-C

Test Result	Parameters	Negative	Positive	Units		
	S _{max}	-95.97	96.63	kN		
	Δ _{max}	-113.25	113.27	mm		
	S _{0.40}	-38.39	38.65	kN		
	Δ _{S0.40}	-6.05	6.62	mm		
	K _e	6.35	5.84	kN/mm		
	Ductility μ	8.49	7.82	mm/mm		
Prediction (Actual Dimensions)	S _{yp}	-84.64	84.64	kN		
	K _p	6.83	6.83	kN/mm		
Prediction (Nominal Dimensions)	S _{yn}	78.10		kN		
	K _n	6.65		kN/mm		
Strain Gauge Results						
Gauge	SG1	SG2	SG3	SG4	SG5	SG6
Max Strain (mm/mm)	15652	13898	16151	16268	16002	16556
Yielding Strain (mm/mm)	1737	1737	1737	1737	1737	1737
Yielding Status	OK	OK	OK	OK	OK	OK

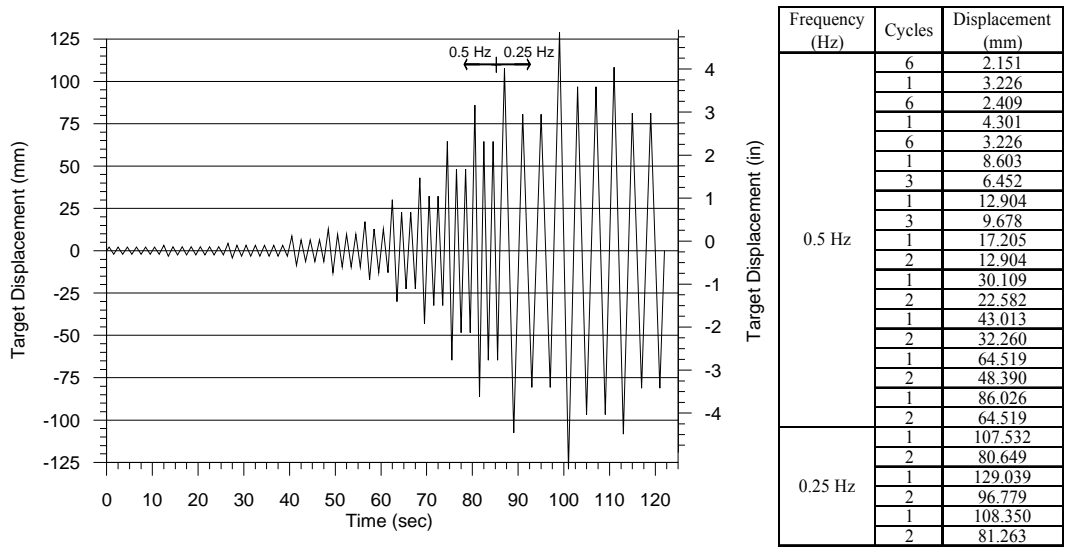

Figure A.40 Reversed cyclic CUREE test protocol for specimen 44 A-C

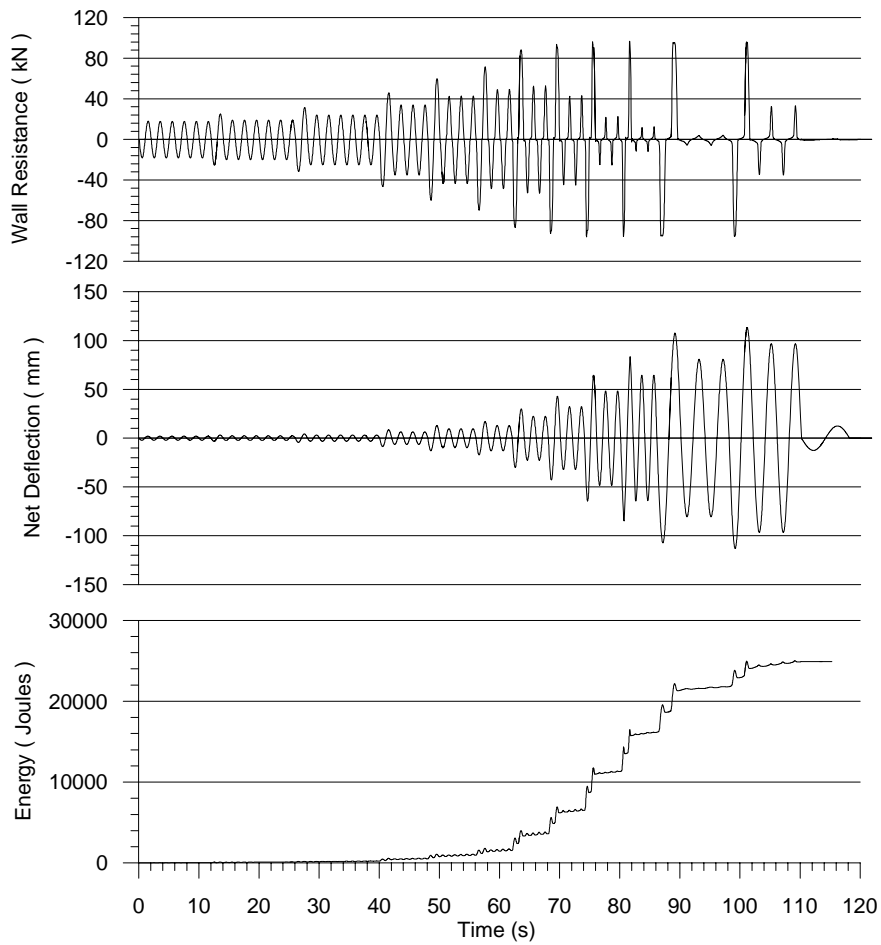

Figure A.41 Time history of specimen 44 A-C

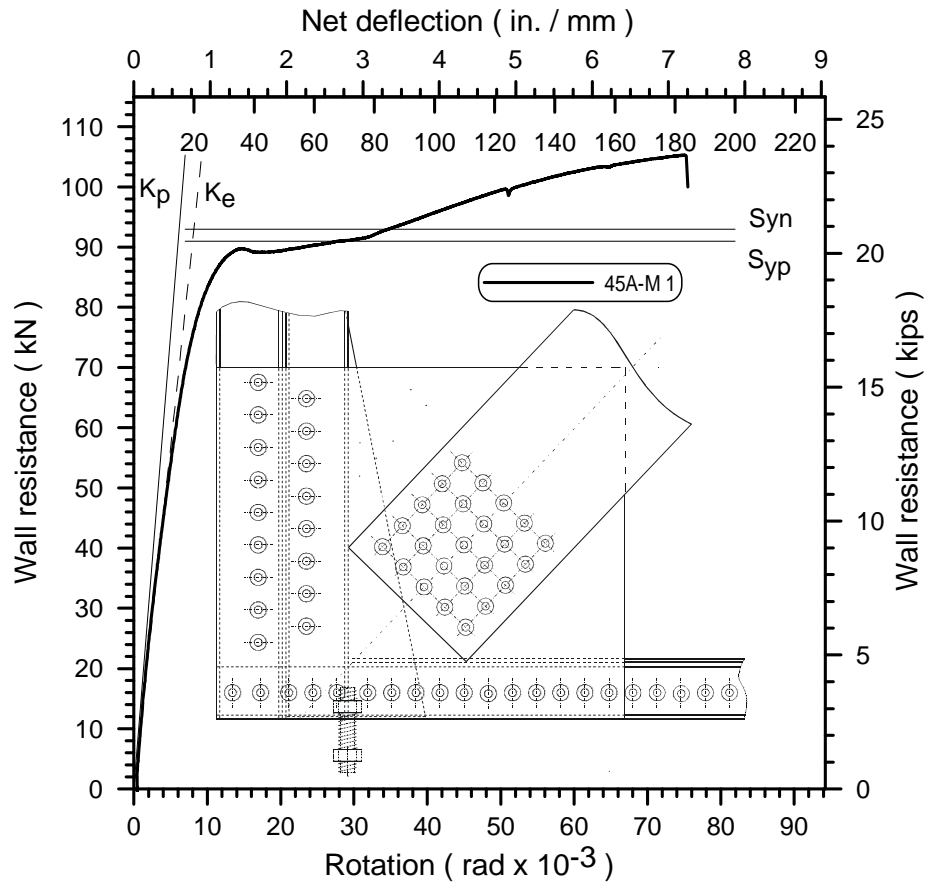

Figure A.42 Monotonic test results specimen 45A-M 1

Table A.22 Monotonic test results specimen 45A-M 1

Test Result	Specimen		45 A-M 1	45 A-M 2	Units
		S_{max}		105.28	NA
	Δ_{max}		184.84	NA	mm
	S_y		89.10	NA	kN
	$S_{0.40}$		42.11	NA	kN
	$\Delta_{S0.40}$		9.04	NA	mm
	K_e		4.66	NA	kN/mm
	Ductility μ		9.67	NA	mm/mm
Prediction (Actual Dimensions)	S_{yp}		90.97	NA	kN
	K_p		6.18	NA	kN/mm
Prediction (Nominal Dimensions)	S_{yn}		84.51	NA	kN
	K_n		6.07	NA	kN/mm
Strain Gauge Results Specimen 45 A-M 1					
Gauge	SG1	SG2	SG3	SG4	SG5
Max Strain (mm/mm)	16103	16242	16380	NA	NA
Yielding Strain (mm/mm)	1737	1737	1737	NA	NA
Yielding Status	OK	OK	OK	NA	NA

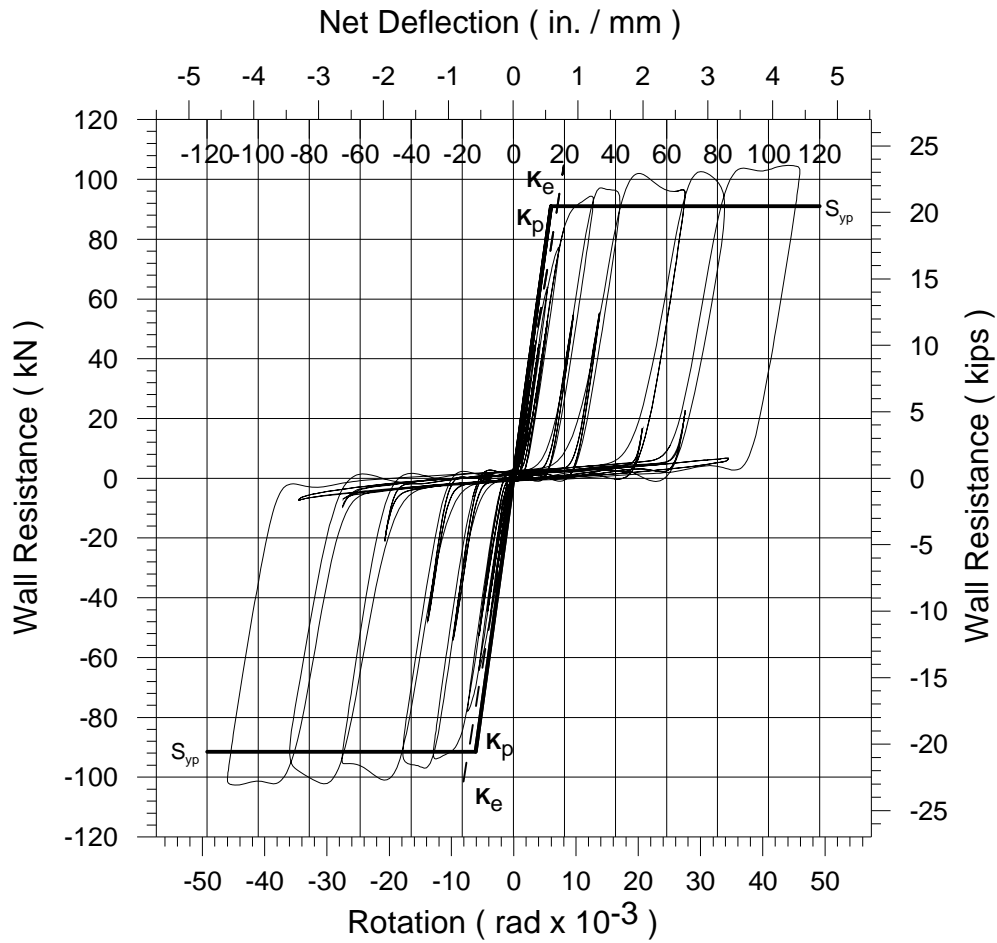

Figure A.43 Cyclic test results specimen 46A-C

Table A.23 Cyclic test results specimen 46A-C

Test Result	Parameters	Negative	Positive	Units		
	S_{max}		-102.63	104.67	kN	
Δ_{max}		-111.99	112.16	mm		
$S_{0.40}$		-41.05	41.87	kN		
$\Delta_{S0.40}$		-7.90	7.93	mm		
K_e		5.20	5.28	kN/mm		
Ductility μ		6.36	6.51	mm/mm		
Prediction (Actual Dimensions)	S_{yp}	-91.50	90.97	kN		
	K_p	6.20	6.18	kN/mm		
Prediction (Nominal Dimensions)	S_{yn}	84.51		kN		
	K_n	6.07		kN/mm		
Strain Gauge Results						
Gauge	SG1	SG2	SG3	SG4	SG5	SG6
Max Strain (mm/mm)	16126	16242	16332	16530	16109	16741
Yielding Strain (mm/mm)	1737	1737	1737	1737	1737	1737
Yielding Status	OK	OK	OK	OK	OK	OK

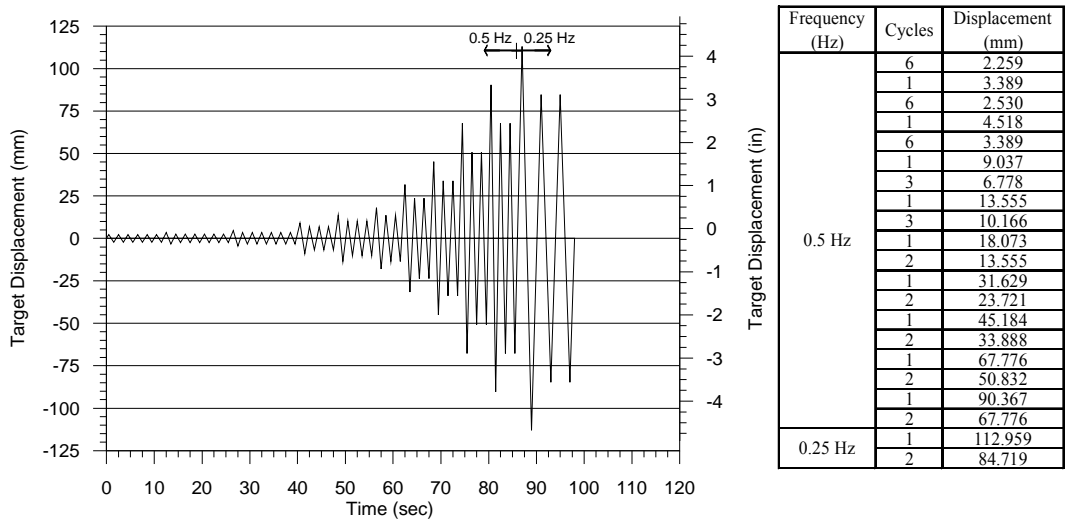

Figure A.44 Reversed cyclic CUREE test protocol for specimen 46 A-C

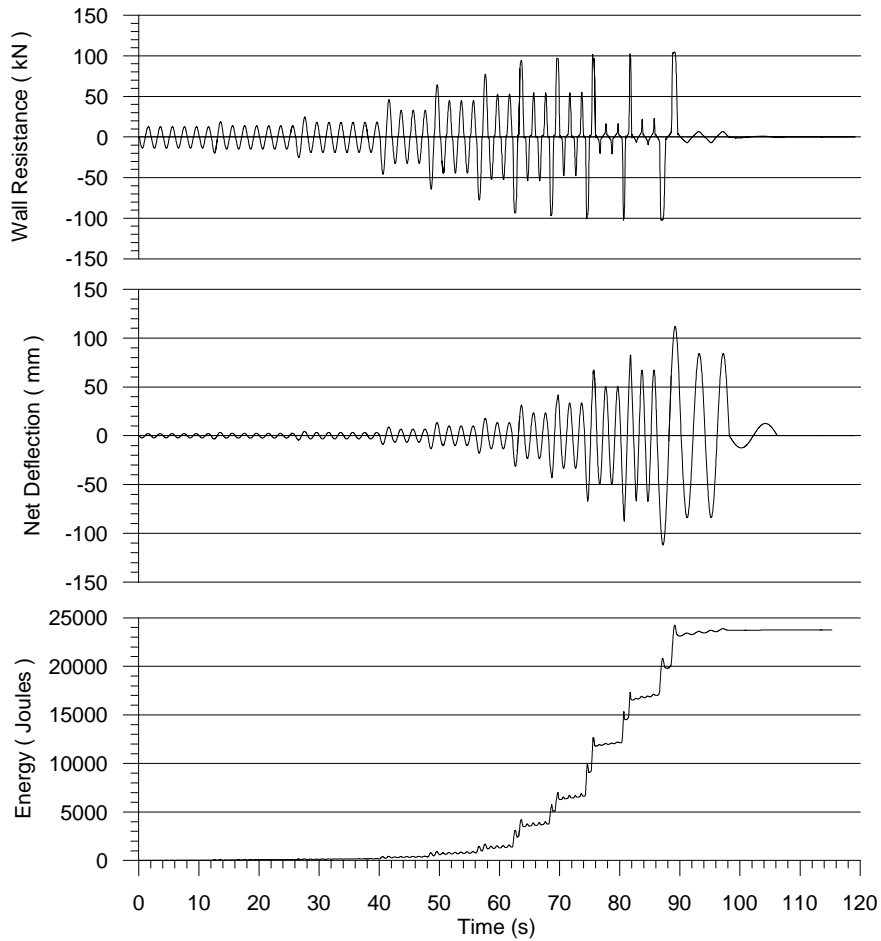

Figure A.45 Time history of specimen 46 A-C

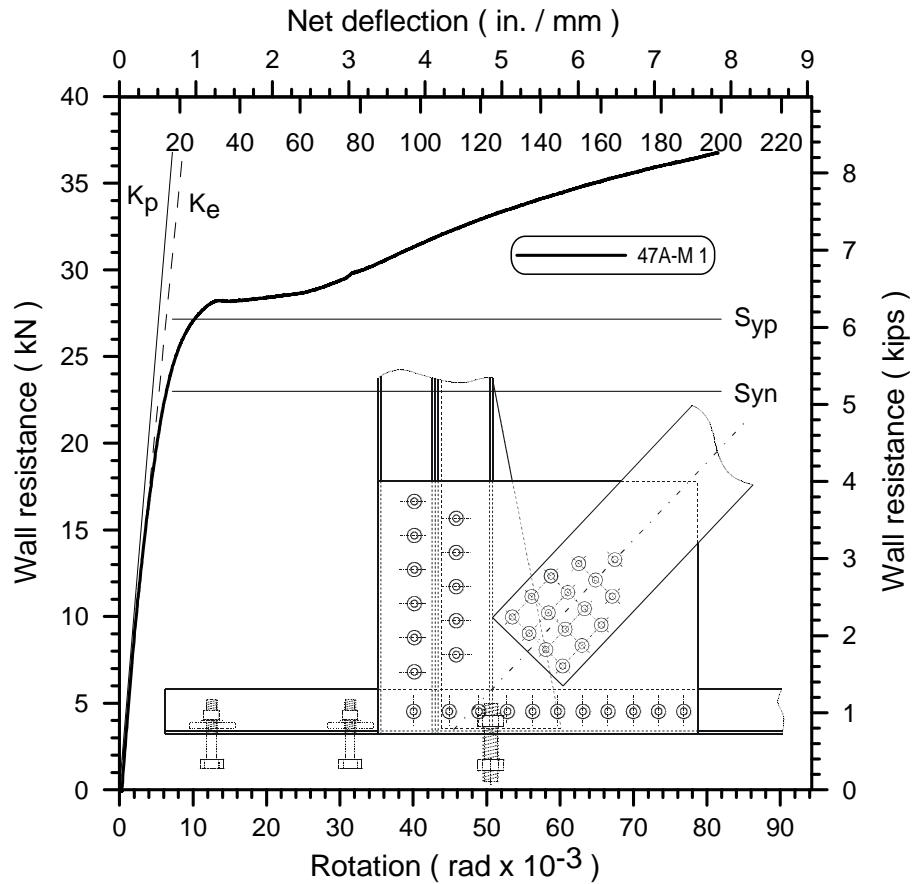

Figure A.46 Monotonic test results specimen 47A-M 1

Table A.24 Monotonic test results specimen 47A-M 1

Test Result	Specimen		47 A-M 1	47 A-M 2	Units
		S_{max}		36.78	NA
	Δ_{max}		200.69	NA	mm
	S_y		28.20	NA	kN
	$S_{0.40}$		14.71	NA	kN
	$\Delta_{S0.40}$		8.40	NA	mm
	K_e		1.75	NA	kN/mm
	Ductility μ		12.47	NA	mm/mm
Prediction (Actual Dimensions)	S_{yp}		27.14	NA	kN
	K_p		2.09	NA	kN/mm
Prediction (Nominal Dimensions)	S_{yn}		22.99	NA	kN
	K_n		2.04	NA	kN/mm
Strain Gauge Results Specimen 47 A-M 1					
Gauge	SG1	SG2	SG3	SG4	SG5
Max Strain (mm/mm)	16128	16262	16403	NA	NA
Yielding Strain (mm/mm)	1906	1906	1906	NA	NA
Yielding Status	OK	OK	OK	NA	NA

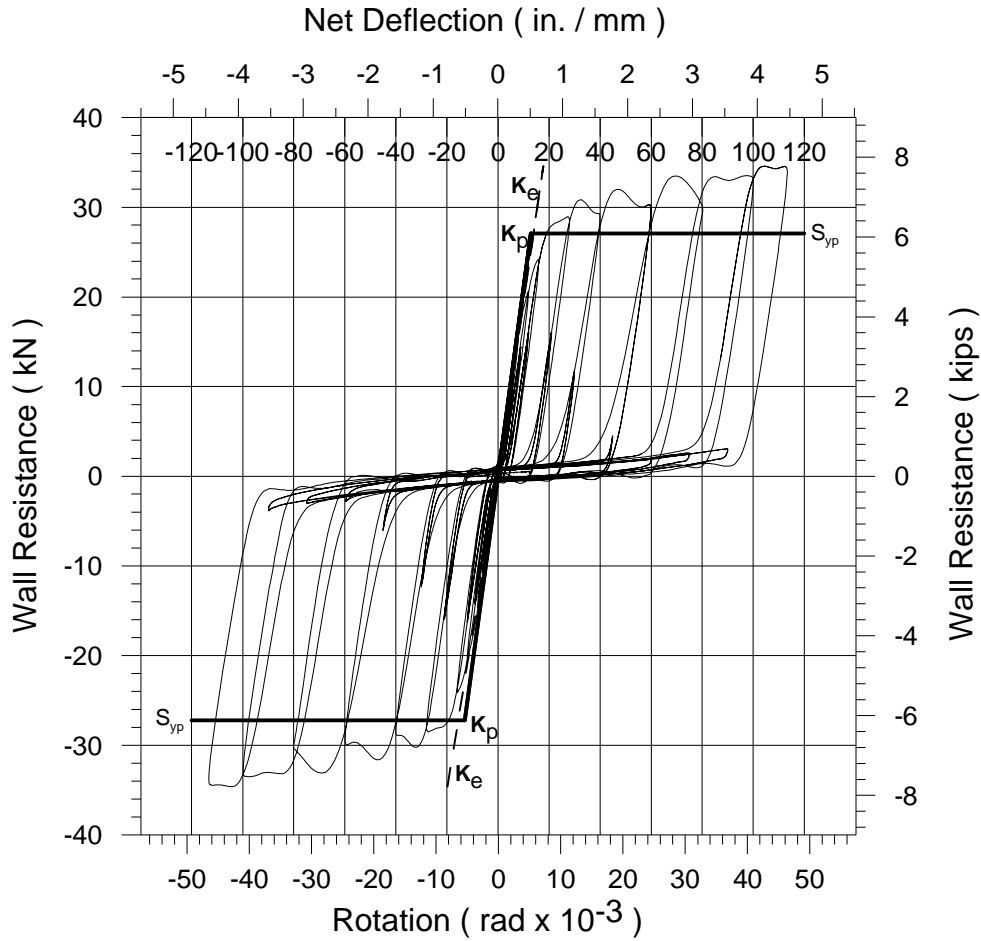

Figure A.47 Cyclic test results specimen 48A-C

Table A.25 Cyclic test results specimen 48A-C

Test Result	Parameters	Negative	Positive	Units		
	S _{max}	-34.63	34.58	kN		
Δ _{max}	-113.28	113.28	mm			
S _{0.40}	-13.85	13.83	kN			
Δ _{S0.40}	-7.92	7.11	mm			
K _e	1.75	1.94	kN/mm			
Ductility μ	7.29	8.13	mm/mm			
Prediction (Actual Dimensions)	S _{yp}	-27.20	27.09	kN		
	K _p	2.10	2.09	kN/mm		
Prediction (Nominal Dimensions)	S _{yn}	22.99		kN		
	K _n	2.04		kN/mm		
Strain Gauge Results						
Gauge	SG1	SG2	SG3	SG4	SG5	SG6
Max Strain (mm/mm)	16188	16204	16294	16407	16319	16733
Yielding Strain (mm/mm)	1906	1906	1906	1906	1906	1906
Yielding Status	OK	OK	OK	OK	OK	OK

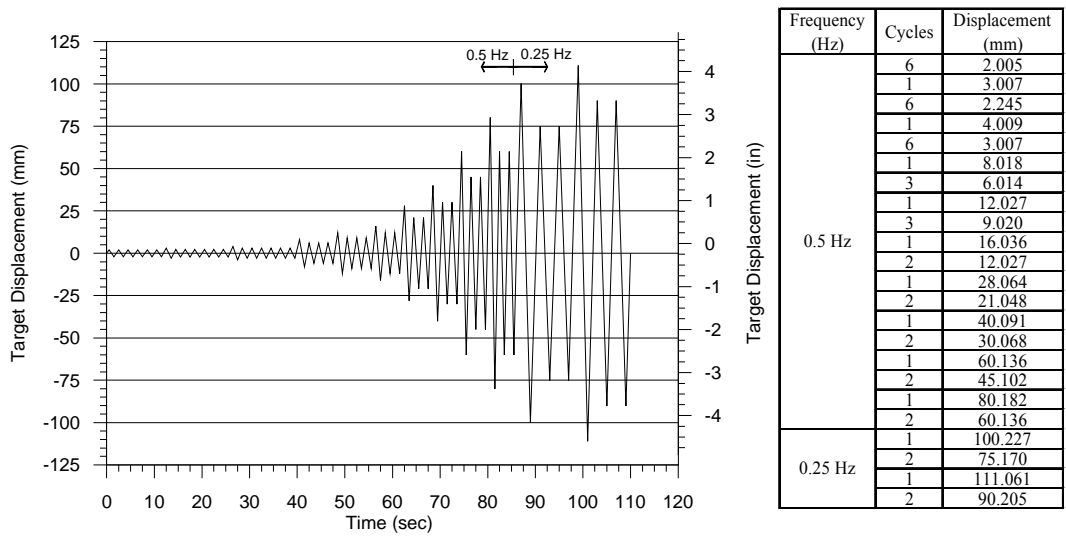

Figure A.48 Reversed cyclic CUREE test protocol for specimen 48 A-C

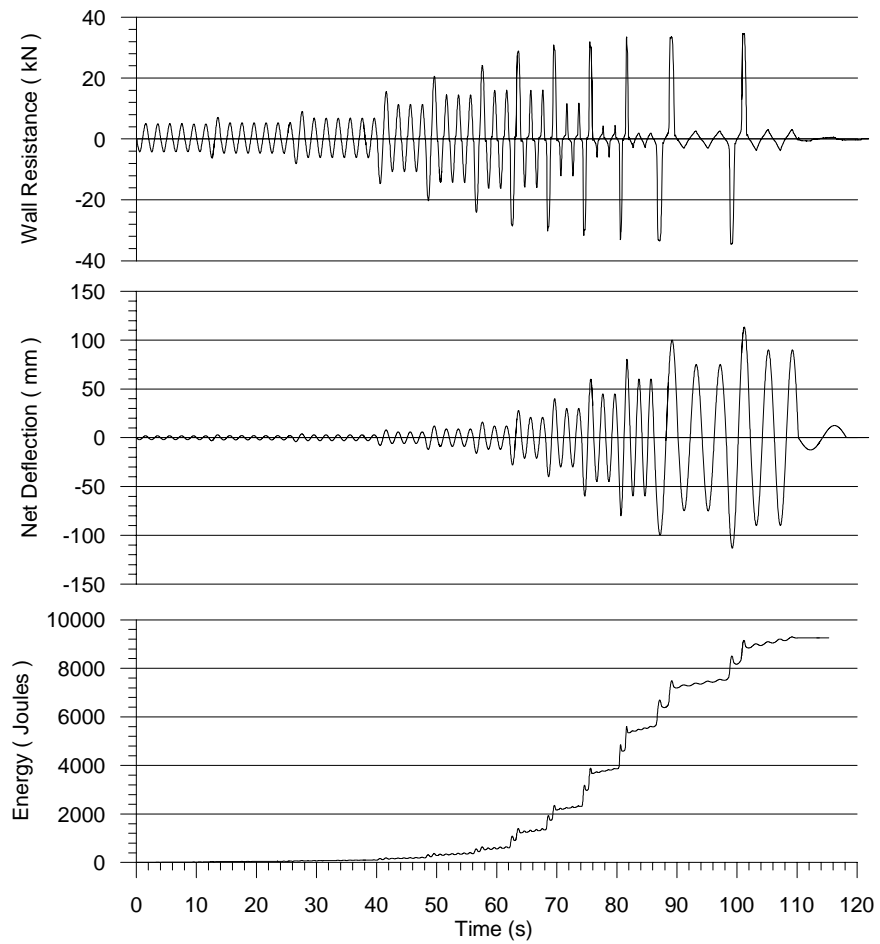

Figure A.49 Time history of specimen 48 A-C

APPENDIX B
STRAIN GAUGE LOCATIONS

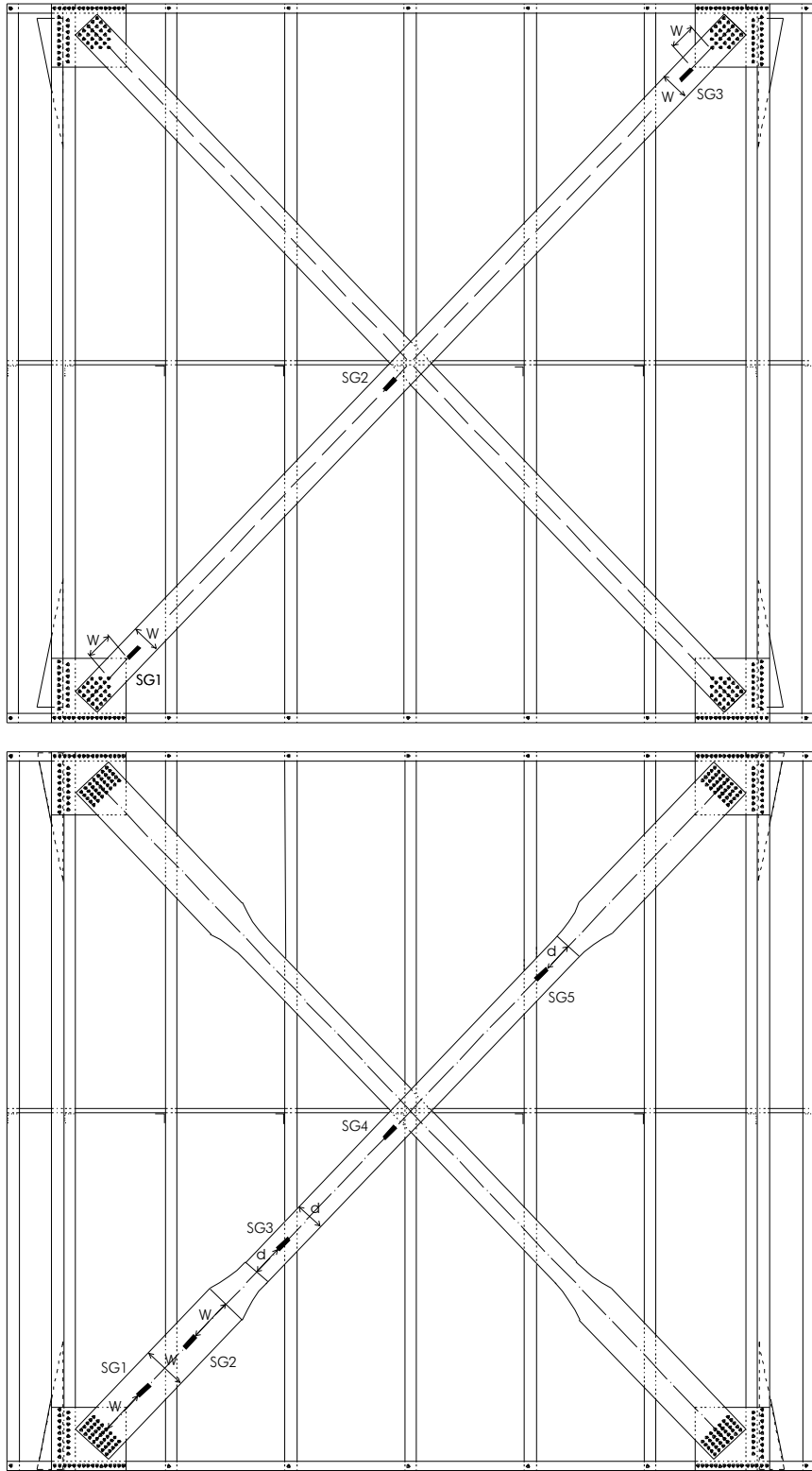

Figure B.1 Strain gauge placement for monotonic test

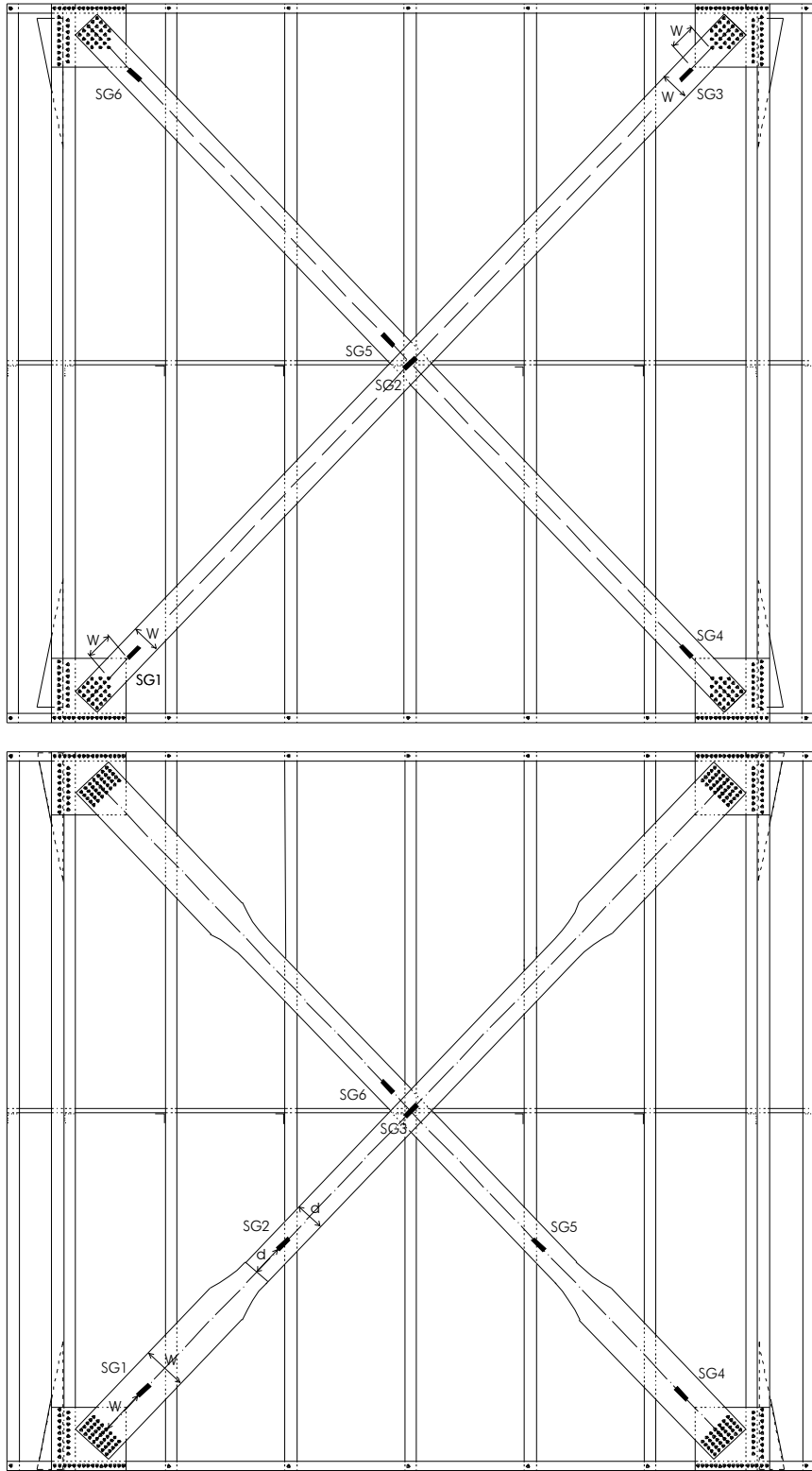

Figure B.2 Strain gauge placement for cyclic test

APPENDIX C

TEST DATA SHEETS AND OBSERVATIONS

Cold Formed Steel Strap Braced Walls McGill University, Montreal																																						
TEST:		9 C-M																																				
RESEARCHER:	Kostadin Velchev	ASSISTANTS:	Gilles Comeau, Nisreen Bah																																			
DATE:	03-May-07	TIME:	14:03																																			
DIMENSIONS OF WALL:	8 FT X 8 FT X 6 IN.	INITIAL STRAP SURVEY:	<table style="font-size: small;"> <tr> <td>Front</td> <td>Right</td> <td>Left</td> </tr> <tr> <td>Back</td> <td>light</td> <td>loose</td> </tr> <tr> <td></td> <td>loose</td> <td>light</td> </tr> </table>	Front	Right	Left	Back	light	loose		loose	light																										
Front	Right	Left																																				
Back	light	loose																																				
	loose	light																																				
STRAP FASTENER CONFIGURATION:		MFR: McGill																																				
STRAP SIZE:	<table style="font-size: x-small;"> <tr><td><input type="checkbox"/></td><td>2.5" 0.043" (1.09mm) 33 ksi (230 MPa)</td></tr> <tr><td><input type="checkbox"/></td><td>2.75" 0.054" (1.37mm) 50 ksi (340 MPa)</td></tr> <tr><td><input type="checkbox"/></td><td>4" 0.068" (1.73mm) 50 ksi (340 MPa)</td></tr> <tr><td><input checked="" type="checkbox"/></td><td>5" 0.043" (1.09) 33 ksi (230 MPa)</td></tr> <tr><td><input type="checkbox"/></td><td>Reduced section strap -- fuse = 2.5" wide x 30" long -- ends = 3.75" wide 0.043" (1.09mm) 33 ksi (230 MPa)</td></tr> <tr><td><input type="checkbox"/></td><td>Reduced section strap -- fuse = 2.75" wide x 30" long -- ends = 4.25" wide 0.054" (1.37mm) 50 ksi (340 MPa)</td></tr> <tr><td><input type="checkbox"/></td><td>Reduced section strap -- fuse = 4" wide x 30" long -- ends = 6" wide 0.068" (1.73mm) 50 ksi (340 MPa)</td></tr> <tr><td><input type="checkbox"/></td><td>Reduced section strap -- fuse = 2.5" wide x 60" long -- ends = 3.75" wide 0.043" (1.09mm) 33 ksi (230 MPa)</td></tr> <tr><td><input type="checkbox"/></td><td>Reduced section strap -- fuse = 4" wide x 60" long -- ends = 6" wide 0.068" (1.73mm) 50 ksi (340 MPa)</td></tr> </table>			<input type="checkbox"/>	2.5" 0.043" (1.09mm) 33 ksi (230 MPa)	<input type="checkbox"/>	2.75" 0.054" (1.37mm) 50 ksi (340 MPa)	<input type="checkbox"/>	4" 0.068" (1.73mm) 50 ksi (340 MPa)	<input checked="" type="checkbox"/>	5" 0.043" (1.09) 33 ksi (230 MPa)	<input type="checkbox"/>	Reduced section strap -- fuse = 2.5" wide x 30" long -- ends = 3.75" wide 0.043" (1.09mm) 33 ksi (230 MPa)	<input type="checkbox"/>	Reduced section strap -- fuse = 2.75" wide x 30" long -- ends = 4.25" wide 0.054" (1.37mm) 50 ksi (340 MPa)	<input type="checkbox"/>	Reduced section strap -- fuse = 4" wide x 30" long -- ends = 6" wide 0.068" (1.73mm) 50 ksi (340 MPa)	<input type="checkbox"/>	Reduced section strap -- fuse = 2.5" wide x 60" long -- ends = 3.75" wide 0.043" (1.09mm) 33 ksi (230 MPa)	<input type="checkbox"/>	Reduced section strap -- fuse = 4" wide x 60" long -- ends = 6" wide 0.068" (1.73mm) 50 ksi (340 MPa)																	
<input type="checkbox"/>	2.5" 0.043" (1.09mm) 33 ksi (230 MPa)																																					
<input type="checkbox"/>	2.75" 0.054" (1.37mm) 50 ksi (340 MPa)																																					
<input type="checkbox"/>	4" 0.068" (1.73mm) 50 ksi (340 MPa)																																					
<input checked="" type="checkbox"/>	5" 0.043" (1.09) 33 ksi (230 MPa)																																					
<input type="checkbox"/>	Reduced section strap -- fuse = 2.5" wide x 30" long -- ends = 3.75" wide 0.043" (1.09mm) 33 ksi (230 MPa)																																					
<input type="checkbox"/>	Reduced section strap -- fuse = 2.75" wide x 30" long -- ends = 4.25" wide 0.054" (1.37mm) 50 ksi (340 MPa)																																					
<input type="checkbox"/>	Reduced section strap -- fuse = 4" wide x 30" long -- ends = 6" wide 0.068" (1.73mm) 50 ksi (340 MPa)																																					
<input type="checkbox"/>	Reduced section strap -- fuse = 2.5" wide x 60" long -- ends = 3.75" wide 0.043" (1.09mm) 33 ksi (230 MPa)																																					
<input type="checkbox"/>	Reduced section strap -- fuse = 4" wide x 60" long -- ends = 6" wide 0.068" (1.73mm) 50 ksi (340 MPa)																																					
INTERIOR STUDS:	<table style="font-size: x-small;"> <tr><td><input type="checkbox"/></td><td>3-5/8"Wx1-5/8"Fx1/2"Lip 0.043" (1.09mm) 33ksi (230 Mpa)</td></tr> <tr><td><input checked="" type="checkbox"/></td><td>6"Wx1-5/8"Fx3/8"Lip 0.043" (1.09mm) 33ksi (230 Mpa)</td></tr> </table>		<input type="checkbox"/>	3-5/8"Wx1-5/8"Fx1/2"Lip 0.043" (1.09mm) 33ksi (230 Mpa)	<input checked="" type="checkbox"/>	6"Wx1-5/8"Fx3/8"Lip 0.043" (1.09mm) 33ksi (230 Mpa)	STUD SPACING:	<table style="font-size: x-small;"> <tr><td><input checked="" type="checkbox"/></td><td>16" O.C.</td></tr> <tr><td><input type="checkbox"/></td><td>Other: _____</td></tr> </table>	<input checked="" type="checkbox"/>	16" O.C.	<input type="checkbox"/>	Other: _____																										
<input type="checkbox"/>	3-5/8"Wx1-5/8"Fx1/2"Lip 0.043" (1.09mm) 33ksi (230 Mpa)																																					
<input checked="" type="checkbox"/>	6"Wx1-5/8"Fx3/8"Lip 0.043" (1.09mm) 33ksi (230 Mpa)																																					
<input checked="" type="checkbox"/>	16" O.C.																																					
<input type="checkbox"/>	Other: _____																																					
BACK-TO-BACK CHORD STUDS:	<table style="font-size: x-small;"> <tr><td><input type="checkbox"/></td><td>3-5/8"Wx1-5/8"Fx1/2"Lip 0.043" (1.09mm) 33ksi (230 Mpa)</td></tr> <tr><td><input checked="" type="checkbox"/></td><td>6"Wx1-5/8"Fx3/8"Lip 0.054" (1.37mm) 50ksi (345 Mpa)</td></tr> <tr><td><input type="checkbox"/></td><td>6"Wx1-5/8"Fx1/2"Lip 0.068" (1.73mm) 50ksi (345 Mpa)</td></tr> </table>			<input type="checkbox"/>	3-5/8"Wx1-5/8"Fx1/2"Lip 0.043" (1.09mm) 33ksi (230 Mpa)	<input checked="" type="checkbox"/>	6"Wx1-5/8"Fx3/8"Lip 0.054" (1.37mm) 50ksi (345 Mpa)	<input type="checkbox"/>	6"Wx1-5/8"Fx1/2"Lip 0.068" (1.73mm) 50ksi (345 Mpa)																													
<input type="checkbox"/>	3-5/8"Wx1-5/8"Fx1/2"Lip 0.043" (1.09mm) 33ksi (230 Mpa)																																					
<input checked="" type="checkbox"/>	6"Wx1-5/8"Fx3/8"Lip 0.054" (1.37mm) 50ksi (345 Mpa)																																					
<input type="checkbox"/>	6"Wx1-5/8"Fx1/2"Lip 0.068" (1.73mm) 50ksi (345 Mpa)																																					
CONNECTIONS:	<table style="font-size: x-small;"> <tr><td>Straps:</td><td><input checked="" type="checkbox"/></td><td>No.10 gauge 0.75" self-drilling wafer head (mod. Truss) Phillips drive</td></tr> <tr><td>Framing:</td><td><input checked="" type="checkbox"/></td><td>No. 8 gauge 0.5" self-drilling wafer head (mod. Truss) Phillips drive</td></tr> <tr><td>Hold downs:</td><td><input checked="" type="checkbox"/></td><td>No.10 gauge 0.75" self-drilling Hex washer head</td></tr> <tr><td>Back-to-Back Chord Studs:</td><td><input checked="" type="checkbox"/></td><td>No.10 gauge 0.75" self-drilling Hex washer head</td></tr> <tr><td>Anchor Rods:</td><td><input type="checkbox"/></td><td>7/8" A307</td></tr> <tr><td></td><td><input checked="" type="checkbox"/></td><td>1" Rod</td></tr> <tr><td>Loading Beam:</td><td><input checked="" type="checkbox"/></td><td>A325 3/4" bolts</td></tr> <tr><td>Base:</td><td><input checked="" type="checkbox"/></td><td>A325 3/4" bolts</td></tr> </table> <table style="font-size: x-small; margin-top: 5px;"> <tr><td>10 bolts:</td><td><input checked="" type="checkbox"/></td><td>2 Anchor Rods</td><td><input checked="" type="checkbox"/></td></tr> <tr><td>6 bolts:</td><td><input checked="" type="checkbox"/></td><td>2 Anchor Rods</td><td><input checked="" type="checkbox"/></td></tr> </table>			Straps:	<input checked="" type="checkbox"/>	No.10 gauge 0.75" self-drilling wafer head (mod. Truss) Phillips drive	Framing:	<input checked="" type="checkbox"/>	No. 8 gauge 0.5" self-drilling wafer head (mod. Truss) Phillips drive	Hold downs:	<input checked="" type="checkbox"/>	No.10 gauge 0.75" self-drilling Hex washer head	Back-to-Back Chord Studs:	<input checked="" type="checkbox"/>	No.10 gauge 0.75" self-drilling Hex washer head	Anchor Rods:	<input type="checkbox"/>	7/8" A307		<input checked="" type="checkbox"/>	1" Rod	Loading Beam:	<input checked="" type="checkbox"/>	A325 3/4" bolts	Base:	<input checked="" type="checkbox"/>	A325 3/4" bolts	10 bolts:	<input checked="" type="checkbox"/>	2 Anchor Rods	<input checked="" type="checkbox"/>	6 bolts:	<input checked="" type="checkbox"/>	2 Anchor Rods	<input checked="" type="checkbox"/>			
Straps:	<input checked="" type="checkbox"/>	No.10 gauge 0.75" self-drilling wafer head (mod. Truss) Phillips drive																																				
Framing:	<input checked="" type="checkbox"/>	No. 8 gauge 0.5" self-drilling wafer head (mod. Truss) Phillips drive																																				
Hold downs:	<input checked="" type="checkbox"/>	No.10 gauge 0.75" self-drilling Hex washer head																																				
Back-to-Back Chord Studs:	<input checked="" type="checkbox"/>	No.10 gauge 0.75" self-drilling Hex washer head																																				
Anchor Rods:	<input type="checkbox"/>	7/8" A307																																				
	<input checked="" type="checkbox"/>	1" Rod																																				
Loading Beam:	<input checked="" type="checkbox"/>	A325 3/4" bolts																																				
Base:	<input checked="" type="checkbox"/>	A325 3/4" bolts																																				
10 bolts:	<input checked="" type="checkbox"/>	2 Anchor Rods	<input checked="" type="checkbox"/>																																			
6 bolts:	<input checked="" type="checkbox"/>	2 Anchor Rods	<input checked="" type="checkbox"/>																																			
TRACK:	<table style="font-size: x-small;"> <tr><td><input type="checkbox"/></td><td>Regular</td><td><input checked="" type="checkbox"/></td><td>6" web</td><td><input checked="" type="checkbox"/></td><td>0.043" (1.09mm) 33ksi (230 Mpa)</td></tr> <tr><td><input type="checkbox"/></td><td>Extended</td><td><input type="checkbox"/></td><td>3 5/8" web</td><td><input type="checkbox"/></td><td>0.054" (1.37mm) 50ksi (345 Mpa)</td></tr> <tr><td><input checked="" type="checkbox"/></td><td>Reinforced</td><td><input type="checkbox"/></td><td>1-1/4" flange</td><td><input type="checkbox"/></td><td>0.068" (1.73mm) 50ksi (345 Mpa)</td></tr> </table>			<input type="checkbox"/>	Regular	<input checked="" type="checkbox"/>	6" web	<input checked="" type="checkbox"/>	0.043" (1.09mm) 33ksi (230 Mpa)	<input type="checkbox"/>	Extended	<input type="checkbox"/>	3 5/8" web	<input type="checkbox"/>	0.054" (1.37mm) 50ksi (345 Mpa)	<input checked="" type="checkbox"/>	Reinforced	<input type="checkbox"/>	1-1/4" flange	<input type="checkbox"/>	0.068" (1.73mm) 50ksi (345 Mpa)																	
<input type="checkbox"/>	Regular	<input checked="" type="checkbox"/>	6" web	<input checked="" type="checkbox"/>	0.043" (1.09mm) 33ksi (230 Mpa)																																	
<input type="checkbox"/>	Extended	<input type="checkbox"/>	3 5/8" web	<input type="checkbox"/>	0.054" (1.37mm) 50ksi (345 Mpa)																																	
<input checked="" type="checkbox"/>	Reinforced	<input type="checkbox"/>	1-1/4" flange	<input type="checkbox"/>	0.068" (1.73mm) 50ksi (345 Mpa)																																	
HOLD DOWNS:	<table style="font-size: x-small;"> <tr><td><input type="checkbox"/></td><td>S/HD10S Simpson</td><td>inside</td><td>outside</td><td>raised</td></tr> <tr><td><input type="checkbox"/></td><td>Fabricated U-shape</td><td></td><td></td><td></td></tr> <tr><td><input type="checkbox"/></td><td>6" x 6" 0.054" (1.37mm) 50 ksi (340 MPa) Gusset Plate w/ S/HD15S Simpson</td><td></td><td></td><td></td></tr> <tr><td><input type="checkbox"/></td><td>7" x 9" 0.054" (1.37mm) 50 ksi (340 MPa) Gusset Plate w/ S/HD15S Simpson</td><td></td><td></td><td></td></tr> <tr><td><input type="checkbox"/></td><td>8" x 8" 0.068" (1.73mm) 50 ksi (340 MPa) Gusset Plate w/ S/HD15S Simpson</td><td></td><td></td><td></td></tr> <tr><td><input type="checkbox"/></td><td>8.5" x 10" 0.068" (1.73mm) 50 ksi (340 MPa) Gusset Plate w/ S/HD15S Simpson</td><td></td><td></td><td></td></tr> <tr><td><input checked="" type="checkbox"/></td><td>10" x 10" 0.054" (1.37mm) 50 ksi (340 MPa) Gusset Plate w/ S/HD15S Simpson</td><td><input checked="" type="checkbox"/></td><td></td><td></td></tr> </table>			<input type="checkbox"/>	S/HD10S Simpson	inside	outside	raised	<input type="checkbox"/>	Fabricated U-shape				<input type="checkbox"/>	6" x 6" 0.054" (1.37mm) 50 ksi (340 MPa) Gusset Plate w/ S/HD15S Simpson				<input type="checkbox"/>	7" x 9" 0.054" (1.37mm) 50 ksi (340 MPa) Gusset Plate w/ S/HD15S Simpson				<input type="checkbox"/>	8" x 8" 0.068" (1.73mm) 50 ksi (340 MPa) Gusset Plate w/ S/HD15S Simpson				<input type="checkbox"/>	8.5" x 10" 0.068" (1.73mm) 50 ksi (340 MPa) Gusset Plate w/ S/HD15S Simpson				<input checked="" type="checkbox"/>	10" x 10" 0.054" (1.37mm) 50 ksi (340 MPa) Gusset Plate w/ S/HD15S Simpson	<input checked="" type="checkbox"/>		
<input type="checkbox"/>	S/HD10S Simpson	inside	outside	raised																																		
<input type="checkbox"/>	Fabricated U-shape																																					
<input type="checkbox"/>	6" x 6" 0.054" (1.37mm) 50 ksi (340 MPa) Gusset Plate w/ S/HD15S Simpson																																					
<input type="checkbox"/>	7" x 9" 0.054" (1.37mm) 50 ksi (340 MPa) Gusset Plate w/ S/HD15S Simpson																																					
<input type="checkbox"/>	8" x 8" 0.068" (1.73mm) 50 ksi (340 MPa) Gusset Plate w/ S/HD15S Simpson																																					
<input type="checkbox"/>	8.5" x 10" 0.068" (1.73mm) 50 ksi (340 MPa) Gusset Plate w/ S/HD15S Simpson																																					
<input checked="" type="checkbox"/>	10" x 10" 0.054" (1.37mm) 50 ksi (340 MPa) Gusset Plate w/ S/HD15S Simpson	<input checked="" type="checkbox"/>																																				
TEST PROTOCOL AND DESCRIPTION:	<table style="font-size: x-small;"> <tr><td><input checked="" type="checkbox"/></td><td>Monotonic (Rate of Loading 2.5 mm/min)</td></tr> <tr><td><input type="checkbox"/></td><td>Cyclic (CUREE cyclic protocol)</td></tr> </table>			<input checked="" type="checkbox"/>	Monotonic (Rate of Loading 2.5 mm/min)	<input type="checkbox"/>	Cyclic (CUREE cyclic protocol)																															
<input checked="" type="checkbox"/>	Monotonic (Rate of Loading 2.5 mm/min)																																					
<input type="checkbox"/>	Cyclic (CUREE cyclic protocol)																																					
LVDT MEASUREMENTS:	<table style="font-size: x-small;"> <tr><td><input checked="" type="checkbox"/></td><td>Actuator LVDT</td><td><input checked="" type="checkbox"/></td><td>North Uplift</td></tr> <tr><td><input checked="" type="checkbox"/></td><td>North Slip</td><td><input checked="" type="checkbox"/></td><td>South Uplift</td></tr> <tr><td><input checked="" type="checkbox"/></td><td>South Slip</td><td><input checked="" type="checkbox"/></td><td>Top of Wall</td></tr> </table>			<input checked="" type="checkbox"/>	Actuator LVDT	<input checked="" type="checkbox"/>	North Uplift	<input checked="" type="checkbox"/>	North Slip	<input checked="" type="checkbox"/>	South Uplift	<input checked="" type="checkbox"/>	South Slip	<input checked="" type="checkbox"/>	Top of Wall																							
<input checked="" type="checkbox"/>	Actuator LVDT	<input checked="" type="checkbox"/>	North Uplift																																			
<input checked="" type="checkbox"/>	North Slip	<input checked="" type="checkbox"/>	South Uplift																																			
<input checked="" type="checkbox"/>	South Slip	<input checked="" type="checkbox"/>	Top of Wall																																			
TOTAL: <input type="text" value="6"/>																																						
STRAP WIDTH BEFORE TEST:	<table style="font-size: x-small; width: 100%;"> <tr> <td style="width: 25%;">Front Right, mm</td> <td style="width: 25%;">Front Left, mm</td> <td style="width: 25%;">Back Right, mm</td> <td style="width: 25%;">Back Left, mm</td> </tr> <tr> <td><input type="text" value="127.58"/></td> <td><input type="text" value="128.55"/></td> <td><input type="text" value="128.19"/></td> <td><input type="text" value="127.68"/></td> </tr> <tr> <td><input type="text" value="127.16"/></td> <td><input type="text" value="127.23"/></td> <td><input type="text" value="127.76"/></td> <td><input type="text" value="127.33"/></td> </tr> <tr> <td><input type="text" value="127.65"/></td> <td><input type="text" value="127.11"/></td> <td><input type="text" value="127.35"/></td> <td><input type="text" value="127.35"/></td> </tr> <tr> <td>AVG</td> <td><input type="text" value="127.46"/></td> <td>AVG</td> <td><input type="text" value="127.63"/></td> </tr> <tr> <td></td> <td>mm</td> <td>AVG</td> <td><input type="text" value="127.77"/></td> </tr> <tr> <td></td> <td></td> <td>AVG</td> <td><input type="text" value="127.45"/></td> </tr> <tr> <td></td> <td></td> <td></td> <td>mm</td> </tr> </table>			Front Right, mm	Front Left, mm	Back Right, mm	Back Left, mm	<input type="text" value="127.58"/>	<input type="text" value="128.55"/>	<input type="text" value="128.19"/>	<input type="text" value="127.68"/>	<input type="text" value="127.16"/>	<input type="text" value="127.23"/>	<input type="text" value="127.76"/>	<input type="text" value="127.33"/>	<input type="text" value="127.65"/>	<input type="text" value="127.11"/>	<input type="text" value="127.35"/>	<input type="text" value="127.35"/>	AVG	<input type="text" value="127.46"/>	AVG	<input type="text" value="127.63"/>		mm	AVG	<input type="text" value="127.77"/>			AVG	<input type="text" value="127.45"/>				mm			
Front Right, mm	Front Left, mm	Back Right, mm	Back Left, mm																																			
<input type="text" value="127.58"/>	<input type="text" value="128.55"/>	<input type="text" value="128.19"/>	<input type="text" value="127.68"/>																																			
<input type="text" value="127.16"/>	<input type="text" value="127.23"/>	<input type="text" value="127.76"/>	<input type="text" value="127.33"/>																																			
<input type="text" value="127.65"/>	<input type="text" value="127.11"/>	<input type="text" value="127.35"/>	<input type="text" value="127.35"/>																																			
AVG	<input type="text" value="127.46"/>	AVG	<input type="text" value="127.63"/>																																			
	mm	AVG	<input type="text" value="127.77"/>																																			
		AVG	<input type="text" value="127.45"/>																																			
			mm																																			
DATA ACQ. RECORD RATE:	1 scan/sec																																					
MONITOR RATE:	10 scan/sec																																					
COMMENTS:	<ul style="list-style-type: none"> -Shear anchors torqued for 10 s with impact wrench -Hold down anchors 1/2 turn from finger tight (load cells used on both hold-downs) -Ambient temperature 20 C -Double chord studs used screwed back to back -Square plate washers (2.5"x2.5") used in all top track connections -Regular washers used in all bottom track connections 																																					

Figure C. 1 Data sheet for test 9 C-M

Cold Formed Steel Strap Braced Walls																																						
McGill University, Montreal																																						
TEST:	25 A-M																																					
RESEARCHER:	Kostadin Velchev	ASSISTANTS:	Gilles Comeau, Nisreen Balh																																			
DATE:	July 04, 2007		TIME:	9:50																																		
DIMENSIONS OF WALL:	8 FT X	8 FT X	3-5/8 IN.	INITIAL STRAP SURVEY:	Front Back	Right tight tight	Left tight tight																															
STRAP FASTENER CONFIGURATION:				MFR: McGill																																		
STRAP SIZE:	<table border="0" style="width:100%;"> <tr><td><input type="checkbox"/></td><td>2.5" 0.043" (1.09mm) 33 ksi (230 MPa)</td></tr> <tr><td><input type="checkbox"/></td><td>2.75" 0.054" (1.37mm) 50 ksi (340 MPa)</td></tr> <tr><td><input type="checkbox"/></td><td>4" 0.068" (1.73mm) 50 ksi (340 MPa)</td></tr> <tr><td><input type="checkbox"/></td><td>5" 0.043" (1.09) 33 ksi (230 MPa)</td></tr> <tr><td><input checked="" type="checkbox"/></td><td>Reduced section strap -- fuse = 2.5" wide x 30" long -- ends = 3.75" wide 0.043" (1.09mm) 33 ksi (230 MPa)</td></tr> <tr><td><input type="checkbox"/></td><td>Reduced section strap -- fuse = 2.75" wide x 30" long -- ends = 4.25" wide 0.054" (1.37mm) 50 ksi (340 MPa)</td></tr> <tr><td><input type="checkbox"/></td><td>Reduced section strap -- fuse = 4" wide x 30" long -- ends = 6" wide 0.068" (1.73mm) 50 ksi (340 MPa)</td></tr> <tr><td><input type="checkbox"/></td><td>Reduced section strap -- fuse = 2.5" wide x 60" long -- ends = 3.75" wide 0.043" (1.09mm) 33 ksi (230 MPa)</td></tr> <tr><td><input type="checkbox"/></td><td>Reduced section strap -- fuse = 4" wide x 60" long -- ends = 6" wide 0.068" (1.73mm) 50 ksi (340 MPa)</td></tr> </table>			<input type="checkbox"/>	2.5" 0.043" (1.09mm) 33 ksi (230 MPa)	<input type="checkbox"/>	2.75" 0.054" (1.37mm) 50 ksi (340 MPa)	<input type="checkbox"/>	4" 0.068" (1.73mm) 50 ksi (340 MPa)	<input type="checkbox"/>	5" 0.043" (1.09) 33 ksi (230 MPa)	<input checked="" type="checkbox"/>	Reduced section strap -- fuse = 2.5" wide x 30" long -- ends = 3.75" wide 0.043" (1.09mm) 33 ksi (230 MPa)	<input type="checkbox"/>	Reduced section strap -- fuse = 2.75" wide x 30" long -- ends = 4.25" wide 0.054" (1.37mm) 50 ksi (340 MPa)	<input type="checkbox"/>	Reduced section strap -- fuse = 4" wide x 30" long -- ends = 6" wide 0.068" (1.73mm) 50 ksi (340 MPa)	<input type="checkbox"/>	Reduced section strap -- fuse = 2.5" wide x 60" long -- ends = 3.75" wide 0.043" (1.09mm) 33 ksi (230 MPa)	<input type="checkbox"/>	Reduced section strap -- fuse = 4" wide x 60" long -- ends = 6" wide 0.068" (1.73mm) 50 ksi (340 MPa)																	
<input type="checkbox"/>	2.5" 0.043" (1.09mm) 33 ksi (230 MPa)																																					
<input type="checkbox"/>	2.75" 0.054" (1.37mm) 50 ksi (340 MPa)																																					
<input type="checkbox"/>	4" 0.068" (1.73mm) 50 ksi (340 MPa)																																					
<input type="checkbox"/>	5" 0.043" (1.09) 33 ksi (230 MPa)																																					
<input checked="" type="checkbox"/>	Reduced section strap -- fuse = 2.5" wide x 30" long -- ends = 3.75" wide 0.043" (1.09mm) 33 ksi (230 MPa)																																					
<input type="checkbox"/>	Reduced section strap -- fuse = 2.75" wide x 30" long -- ends = 4.25" wide 0.054" (1.37mm) 50 ksi (340 MPa)																																					
<input type="checkbox"/>	Reduced section strap -- fuse = 4" wide x 30" long -- ends = 6" wide 0.068" (1.73mm) 50 ksi (340 MPa)																																					
<input type="checkbox"/>	Reduced section strap -- fuse = 2.5" wide x 60" long -- ends = 3.75" wide 0.043" (1.09mm) 33 ksi (230 MPa)																																					
<input type="checkbox"/>	Reduced section strap -- fuse = 4" wide x 60" long -- ends = 6" wide 0.068" (1.73mm) 50 ksi (340 MPa)																																					
INTERIOR STUDS:	<table border="0" style="width:100%;"> <tr><td><input checked="" type="checkbox"/></td><td>3-5/8"Wx1-5/8"Fx1/2"Lip 0.043" (1.09mm) 33ksi (230 MPa)</td></tr> <tr><td><input type="checkbox"/></td><td>6"Wx1-5/8"Fx1/2"Lip 0.043" (1.09mm) 33ksi (230 MPa)</td></tr> </table>		<input checked="" type="checkbox"/>	3-5/8"Wx1-5/8"Fx1/2"Lip 0.043" (1.09mm) 33ksi (230 MPa)	<input type="checkbox"/>	6"Wx1-5/8"Fx1/2"Lip 0.043" (1.09mm) 33ksi (230 MPa)	STUD SPACING:	<input checked="" type="checkbox"/> 16" O.C. <input type="checkbox"/> Other : _____																														
<input checked="" type="checkbox"/>	3-5/8"Wx1-5/8"Fx1/2"Lip 0.043" (1.09mm) 33ksi (230 MPa)																																					
<input type="checkbox"/>	6"Wx1-5/8"Fx1/2"Lip 0.043" (1.09mm) 33ksi (230 MPa)																																					
BACK-TO-BACK CHORD STUDS:	<table border="0" style="width:100%;"> <tr><td><input checked="" type="checkbox"/></td><td>3-5/8"Wx1-5/8"Fx1/2"Lip 0.043" (1.09mm) 33ksi (230 MPa)</td></tr> <tr><td><input type="checkbox"/></td><td>6"Wx1-5/8"Fx1/2"Lip 0.054" (1.37mm) 50ksi (345 MPa)</td></tr> <tr><td><input type="checkbox"/></td><td>6"Wx1-5/8"Fx1/2"Lip 0.068" (1.73mm) 50ksi (345 MPa)</td></tr> </table>			<input checked="" type="checkbox"/>	3-5/8"Wx1-5/8"Fx1/2"Lip 0.043" (1.09mm) 33ksi (230 MPa)	<input type="checkbox"/>	6"Wx1-5/8"Fx1/2"Lip 0.054" (1.37mm) 50ksi (345 MPa)	<input type="checkbox"/>	6"Wx1-5/8"Fx1/2"Lip 0.068" (1.73mm) 50ksi (345 MPa)																													
<input checked="" type="checkbox"/>	3-5/8"Wx1-5/8"Fx1/2"Lip 0.043" (1.09mm) 33ksi (230 MPa)																																					
<input type="checkbox"/>	6"Wx1-5/8"Fx1/2"Lip 0.054" (1.37mm) 50ksi (345 MPa)																																					
<input type="checkbox"/>	6"Wx1-5/8"Fx1/2"Lip 0.068" (1.73mm) 50ksi (345 MPa)																																					
CONNECTIONS:	<table border="0" style="width:100%;"> <tr><td>Straps:</td><td><input checked="" type="checkbox"/></td><td>No.10 gauge 0.75" self-drilling wafer head (mod. Truss) Phillips drive</td></tr> <tr><td>Framing:</td><td><input checked="" type="checkbox"/></td><td>No.8 gauge 0.5" self-drilling wafer head (mod. Truss) Phillips drive</td></tr> <tr><td>Hold downs:</td><td><input checked="" type="checkbox"/></td><td>No.14 gauge 3/4" self-drilling Hex washer head</td></tr> <tr><td>Back-to-Back Chord Studs:</td><td><input checked="" type="checkbox"/></td><td>No.10 gauge 0.75" self-drilling Hex washer head</td></tr> <tr><td>Anchor Rods:</td><td><input checked="" type="checkbox"/></td><td>7/8" A307</td></tr> <tr><td>Loading Beam:</td><td><input checked="" type="checkbox"/></td><td>A325 3/4" bolts</td></tr> <tr><td>Base:</td><td><input checked="" type="checkbox"/></td><td>A325 3/4" bolts</td></tr> </table>			Straps:	<input checked="" type="checkbox"/>	No.10 gauge 0.75" self-drilling wafer head (mod. Truss) Phillips drive	Framing:	<input checked="" type="checkbox"/>	No.8 gauge 0.5" self-drilling wafer head (mod. Truss) Phillips drive	Hold downs:	<input checked="" type="checkbox"/>	No.14 gauge 3/4" self-drilling Hex washer head	Back-to-Back Chord Studs:	<input checked="" type="checkbox"/>	No.10 gauge 0.75" self-drilling Hex washer head	Anchor Rods:	<input checked="" type="checkbox"/>	7/8" A307	Loading Beam:	<input checked="" type="checkbox"/>	A325 3/4" bolts	Base:	<input checked="" type="checkbox"/>	A325 3/4" bolts														
Straps:	<input checked="" type="checkbox"/>	No.10 gauge 0.75" self-drilling wafer head (mod. Truss) Phillips drive																																				
Framing:	<input checked="" type="checkbox"/>	No.8 gauge 0.5" self-drilling wafer head (mod. Truss) Phillips drive																																				
Hold downs:	<input checked="" type="checkbox"/>	No.14 gauge 3/4" self-drilling Hex washer head																																				
Back-to-Back Chord Studs:	<input checked="" type="checkbox"/>	No.10 gauge 0.75" self-drilling Hex washer head																																				
Anchor Rods:	<input checked="" type="checkbox"/>	7/8" A307																																				
Loading Beam:	<input checked="" type="checkbox"/>	A325 3/4" bolts																																				
Base:	<input checked="" type="checkbox"/>	A325 3/4" bolts																																				
TRACK:	<table border="0" style="width:100%;"> <tr><td><input type="checkbox"/></td><td>Regular</td><td><input type="checkbox"/></td><td>6" web</td><td><input checked="" type="checkbox"/></td><td>0.043" (1.09mm) 33ksi (230 MPa)</td></tr> <tr><td><input checked="" type="checkbox"/></td><td>Extended</td><td><input checked="" type="checkbox"/></td><td>3 5/8" web</td><td><input type="checkbox"/></td><td>0.054" (1.37mm) 50ksi (345 MPa)</td></tr> <tr><td><input type="checkbox"/></td><td>Reinforced</td><td><input type="checkbox"/></td><td>1-1/4" flange</td><td><input type="checkbox"/></td><td>0.068" (1.73mm) 50ksi (345 MPa)</td></tr> </table>			<input type="checkbox"/>	Regular	<input type="checkbox"/>	6" web	<input checked="" type="checkbox"/>	0.043" (1.09mm) 33ksi (230 MPa)	<input checked="" type="checkbox"/>	Extended	<input checked="" type="checkbox"/>	3 5/8" web	<input type="checkbox"/>	0.054" (1.37mm) 50ksi (345 MPa)	<input type="checkbox"/>	Reinforced	<input type="checkbox"/>	1-1/4" flange	<input type="checkbox"/>	0.068" (1.73mm) 50ksi (345 MPa)																	
<input type="checkbox"/>	Regular	<input type="checkbox"/>	6" web	<input checked="" type="checkbox"/>	0.043" (1.09mm) 33ksi (230 MPa)																																	
<input checked="" type="checkbox"/>	Extended	<input checked="" type="checkbox"/>	3 5/8" web	<input type="checkbox"/>	0.054" (1.37mm) 50ksi (345 MPa)																																	
<input type="checkbox"/>	Reinforced	<input type="checkbox"/>	1-1/4" flange	<input type="checkbox"/>	0.068" (1.73mm) 50ksi (345 MPa)																																	
HOLD DOWNS:	<table border="0" style="width:100%;"> <tr><td><input checked="" type="checkbox"/></td><td>S/HD10S Simpson</td><td style="text-align: center;">inside</td><td style="text-align: center;">outside</td><td style="text-align: center;">raised</td></tr> <tr><td><input type="checkbox"/></td><td>Fabricated U-shape</td><td style="text-align: center;"><input checked="" type="checkbox"/></td><td style="text-align: center;"><input type="checkbox"/></td><td style="text-align: center;"><input type="checkbox"/></td></tr> <tr><td><input type="checkbox"/></td><td>6" x 6" 0.054" (1.37mm) 50 ksi (340 MPa) Gusset Plate w/ S/HD15S Simpson</td><td style="text-align: center;"><input type="checkbox"/></td><td style="text-align: center;"><input type="checkbox"/></td><td style="text-align: center;"><input type="checkbox"/></td></tr> <tr><td><input type="checkbox"/></td><td>7" x 9" 0.054" (1.37mm) 50 ksi (340 MPa) Gusset Plate w/ S/HD15S Simpson</td><td style="text-align: center;"><input type="checkbox"/></td><td style="text-align: center;"><input type="checkbox"/></td><td style="text-align: center;"><input type="checkbox"/></td></tr> <tr><td><input type="checkbox"/></td><td>8" x 8" 0.068" (1.73mm) 50 ksi (340 MPa) Gusset Plate w/ S/HD15S Simpson</td><td style="text-align: center;"><input type="checkbox"/></td><td style="text-align: center;"><input type="checkbox"/></td><td style="text-align: center;"><input type="checkbox"/></td></tr> <tr><td><input type="checkbox"/></td><td>8.5" x 10" 0.068" (1.73mm) 50 ksi (340 MPa) Gusset Plate w/ S/HD15S Simpson</td><td style="text-align: center;"><input type="checkbox"/></td><td style="text-align: center;"><input type="checkbox"/></td><td style="text-align: center;"><input type="checkbox"/></td></tr> <tr><td><input type="checkbox"/></td><td>10" x 10" 0.054" (1.37mm) 50 ksi (340 MPa) Gusset Plate w/ S/HD15S Simpson</td><td style="text-align: center;"><input type="checkbox"/></td><td style="text-align: center;"><input type="checkbox"/></td><td style="text-align: center;"><input type="checkbox"/></td></tr> </table>			<input checked="" type="checkbox"/>	S/HD10S Simpson	inside	outside	raised	<input type="checkbox"/>	Fabricated U-shape	<input checked="" type="checkbox"/>	<input type="checkbox"/>	<input type="checkbox"/>	<input type="checkbox"/>	6" x 6" 0.054" (1.37mm) 50 ksi (340 MPa) Gusset Plate w/ S/HD15S Simpson	<input type="checkbox"/>	<input type="checkbox"/>	<input type="checkbox"/>	<input type="checkbox"/>	7" x 9" 0.054" (1.37mm) 50 ksi (340 MPa) Gusset Plate w/ S/HD15S Simpson	<input type="checkbox"/>	<input type="checkbox"/>	<input type="checkbox"/>	<input type="checkbox"/>	8" x 8" 0.068" (1.73mm) 50 ksi (340 MPa) Gusset Plate w/ S/HD15S Simpson	<input type="checkbox"/>	<input type="checkbox"/>	<input type="checkbox"/>	<input type="checkbox"/>	8.5" x 10" 0.068" (1.73mm) 50 ksi (340 MPa) Gusset Plate w/ S/HD15S Simpson	<input type="checkbox"/>	<input type="checkbox"/>	<input type="checkbox"/>	<input type="checkbox"/>	10" x 10" 0.054" (1.37mm) 50 ksi (340 MPa) Gusset Plate w/ S/HD15S Simpson	<input type="checkbox"/>	<input type="checkbox"/>	<input type="checkbox"/>
<input checked="" type="checkbox"/>	S/HD10S Simpson	inside	outside	raised																																		
<input type="checkbox"/>	Fabricated U-shape	<input checked="" type="checkbox"/>	<input type="checkbox"/>	<input type="checkbox"/>																																		
<input type="checkbox"/>	6" x 6" 0.054" (1.37mm) 50 ksi (340 MPa) Gusset Plate w/ S/HD15S Simpson	<input type="checkbox"/>	<input type="checkbox"/>	<input type="checkbox"/>																																		
<input type="checkbox"/>	7" x 9" 0.054" (1.37mm) 50 ksi (340 MPa) Gusset Plate w/ S/HD15S Simpson	<input type="checkbox"/>	<input type="checkbox"/>	<input type="checkbox"/>																																		
<input type="checkbox"/>	8" x 8" 0.068" (1.73mm) 50 ksi (340 MPa) Gusset Plate w/ S/HD15S Simpson	<input type="checkbox"/>	<input type="checkbox"/>	<input type="checkbox"/>																																		
<input type="checkbox"/>	8.5" x 10" 0.068" (1.73mm) 50 ksi (340 MPa) Gusset Plate w/ S/HD15S Simpson	<input type="checkbox"/>	<input type="checkbox"/>	<input type="checkbox"/>																																		
<input type="checkbox"/>	10" x 10" 0.054" (1.37mm) 50 ksi (340 MPa) Gusset Plate w/ S/HD15S Simpson	<input type="checkbox"/>	<input type="checkbox"/>	<input type="checkbox"/>																																		
TEST PROTOCOL AND DESCRIPTION:	<table border="0" style="width:100%;"> <tr><td><input checked="" type="checkbox"/></td><td>Monotonic (Rate of Loading 2.5 mm/min)</td></tr> <tr><td><input type="checkbox"/></td><td>Cyclic (CUREE cyclic protocol)</td></tr> </table>			<input checked="" type="checkbox"/>	Monotonic (Rate of Loading 2.5 mm/min)	<input type="checkbox"/>	Cyclic (CUREE cyclic protocol)																															
<input checked="" type="checkbox"/>	Monotonic (Rate of Loading 2.5 mm/min)																																					
<input type="checkbox"/>	Cyclic (CUREE cyclic protocol)																																					
LVDT MEASUREMENTS:	<table border="0" style="width:100%;"> <tr><td><input checked="" type="checkbox"/></td><td>Actuator LVDT</td><td><input checked="" type="checkbox"/></td><td>North Uplift</td></tr> <tr><td><input checked="" type="checkbox"/></td><td>North Slip</td><td><input checked="" type="checkbox"/></td><td>South Uplift</td></tr> <tr><td><input checked="" type="checkbox"/></td><td>South Slip</td><td><input checked="" type="checkbox"/></td><td>Top of Wall</td></tr> </table>			<input checked="" type="checkbox"/>	Actuator LVDT	<input checked="" type="checkbox"/>	North Uplift	<input checked="" type="checkbox"/>	North Slip	<input checked="" type="checkbox"/>	South Uplift	<input checked="" type="checkbox"/>	South Slip	<input checked="" type="checkbox"/>	Top of Wall																							
<input checked="" type="checkbox"/>	Actuator LVDT	<input checked="" type="checkbox"/>	North Uplift																																			
<input checked="" type="checkbox"/>	North Slip	<input checked="" type="checkbox"/>	South Uplift																																			
<input checked="" type="checkbox"/>	South Slip	<input checked="" type="checkbox"/>	Top of Wall																																			
TOTAL: <input type="text" value="6"/>																																						
STRAP WIDTH BEFORE TEST:	<table border="0" style="width:100%;"> <tr><td style="text-align: center;">Front Right</td><td style="text-align: center;">Front Left, mm</td><td style="text-align: center;">Back Right, mm</td><td style="text-align: center;">Back Left, mm</td></tr> <tr><td style="text-align: center;"><input type="text" value="63.75"/></td><td style="text-align: center;"><input type="text" value="64.00"/></td><td style="text-align: center;"><input type="text" value="63.05"/></td><td style="text-align: center;"><input type="text" value="63.59"/></td></tr> <tr><td style="text-align: center;"><input type="text" value="63.62"/></td><td style="text-align: center;"><input type="text" value="63.44"/></td><td style="text-align: center;"><input type="text" value="63.43"/></td><td style="text-align: center;"><input type="text" value="63.71"/></td></tr> <tr><td style="text-align: center;"><input type="text" value="63.88"/></td><td style="text-align: center;"><input type="text" value="64.03"/></td><td style="text-align: center;"><input type="text" value="63.84"/></td><td style="text-align: center;"><input type="text" value="63.84"/></td></tr> <tr><td style="text-align: center;">AVG <input type="text" value="63.75"/></td><td style="text-align: center;">AVG <input type="text" value="63.82"/></td><td style="text-align: center;">AVG <input type="text" value="63.44"/></td><td style="text-align: center;">AVG <input type="text" value="63.71"/></td></tr> </table>			Front Right	Front Left, mm	Back Right, mm	Back Left, mm	<input type="text" value="63.75"/>	<input type="text" value="64.00"/>	<input type="text" value="63.05"/>	<input type="text" value="63.59"/>	<input type="text" value="63.62"/>	<input type="text" value="63.44"/>	<input type="text" value="63.43"/>	<input type="text" value="63.71"/>	<input type="text" value="63.88"/>	<input type="text" value="64.03"/>	<input type="text" value="63.84"/>	<input type="text" value="63.84"/>	AVG <input type="text" value="63.75"/>	AVG <input type="text" value="63.82"/>	AVG <input type="text" value="63.44"/>	AVG <input type="text" value="63.71"/>															
Front Right	Front Left, mm	Back Right, mm	Back Left, mm																																			
<input type="text" value="63.75"/>	<input type="text" value="64.00"/>	<input type="text" value="63.05"/>	<input type="text" value="63.59"/>																																			
<input type="text" value="63.62"/>	<input type="text" value="63.44"/>	<input type="text" value="63.43"/>	<input type="text" value="63.71"/>																																			
<input type="text" value="63.88"/>	<input type="text" value="64.03"/>	<input type="text" value="63.84"/>	<input type="text" value="63.84"/>																																			
AVG <input type="text" value="63.75"/>	AVG <input type="text" value="63.82"/>	AVG <input type="text" value="63.44"/>	AVG <input type="text" value="63.71"/>																																			
DATA ACQ. RECORD RATE:	1 scan/sec																																					
MONITOR RATE:	10 scan/sec																																					
COMMENTS:	<ul style="list-style-type: none"> -Shear anchors torqued for 10 s with impact wrench -Hold down anchors 1/2 turn from finger tight (load cells used on both hold-downs) -Ambient temperature 25 C -Double chord studs used screwed back to back -Square plate washers (2.5"x2.5") used in all top track connections -Regular washers used in all bottom track connections 																																					

Figure C. 2 Data sheet for test 25 A-M

Cold Formed Steel Strap Braced Walls McGill University, Montreal																																																																					
TEST:	26 A-C																																																																				
RESEARCHER:	Kostadin Velchev	ASSISTANTS:	Gilles Comeau, Nisreen Balh																																																																		
DATE:	23-Jul-07		TIME:	11:14																																																																	
DIMENSIONS OF WALL:	8 FT X	8 FT X	3-5/8 IN.	INITIAL STRAP SURVEY: Front Back Right tight Left tight																																																																	
STRAP FASTENER CONFIGURATION: MFR: McGill																																																																					
STRAP SIZE:	<table border="1" style="width:100%; border-collapse: collapse;"> <tr><td><input checked="" type="checkbox"/></td><td>2.5" 0.043" (1.09mm) 33 ksi (230 MPa)</td></tr> <tr><td><input type="checkbox"/></td><td>2.75" 0.054" (1.37mm) 50 ksi (340 MPa)</td></tr> <tr><td><input type="checkbox"/></td><td>4" 0.068" (1.73mm) 50 ksi (340 MPa)</td></tr> <tr><td><input type="checkbox"/></td><td>5" 0.043" (1.09) 33 ksi (230 MPa)</td></tr> <tr><td><input type="checkbox"/></td><td>Reduced section strap -- fuse = 2.5" wide x 30" long -- ends = 3.75" wide x 0.043" (1.09mm) 33 ksi (230 MPa)</td></tr> <tr><td><input type="checkbox"/></td><td>Reduced section strap -- fuse = 2.75" wide x 30" long -- ends = 4.25" wide x 0.054" (1.37mm) 50 ksi (340 MPa)</td></tr> <tr><td><input type="checkbox"/></td><td>Reduced section strap -- fuse = 4" wide x 30" long -- ends = 6" wide x 0.068" (1.73mm) 50 ksi (340 MPa)</td></tr> <tr><td><input type="checkbox"/></td><td>Reduced section strap -- fuse = 2.5" wide x 60" long -- ends = 3.75" wide x 0.043" (1.09mm) 33 ksi (230 MPa)</td></tr> <tr><td><input type="checkbox"/></td><td>Reduced section strap -- fuse = 4" wide x 60" long -- ends = 6" wide x 0.068" (1.73mm) 50 ksi (340 MPa)</td></tr> </table>			<input checked="" type="checkbox"/>	2.5" 0.043" (1.09mm) 33 ksi (230 MPa)	<input type="checkbox"/>	2.75" 0.054" (1.37mm) 50 ksi (340 MPa)	<input type="checkbox"/>	4" 0.068" (1.73mm) 50 ksi (340 MPa)	<input type="checkbox"/>	5" 0.043" (1.09) 33 ksi (230 MPa)	<input type="checkbox"/>	Reduced section strap -- fuse = 2.5" wide x 30" long -- ends = 3.75" wide x 0.043" (1.09mm) 33 ksi (230 MPa)	<input type="checkbox"/>	Reduced section strap -- fuse = 2.75" wide x 30" long -- ends = 4.25" wide x 0.054" (1.37mm) 50 ksi (340 MPa)	<input type="checkbox"/>	Reduced section strap -- fuse = 4" wide x 30" long -- ends = 6" wide x 0.068" (1.73mm) 50 ksi (340 MPa)	<input type="checkbox"/>	Reduced section strap -- fuse = 2.5" wide x 60" long -- ends = 3.75" wide x 0.043" (1.09mm) 33 ksi (230 MPa)	<input type="checkbox"/>	Reduced section strap -- fuse = 4" wide x 60" long -- ends = 6" wide x 0.068" (1.73mm) 50 ksi (340 MPa)																																																
<input checked="" type="checkbox"/>	2.5" 0.043" (1.09mm) 33 ksi (230 MPa)																																																																				
<input type="checkbox"/>	2.75" 0.054" (1.37mm) 50 ksi (340 MPa)																																																																				
<input type="checkbox"/>	4" 0.068" (1.73mm) 50 ksi (340 MPa)																																																																				
<input type="checkbox"/>	5" 0.043" (1.09) 33 ksi (230 MPa)																																																																				
<input type="checkbox"/>	Reduced section strap -- fuse = 2.5" wide x 30" long -- ends = 3.75" wide x 0.043" (1.09mm) 33 ksi (230 MPa)																																																																				
<input type="checkbox"/>	Reduced section strap -- fuse = 2.75" wide x 30" long -- ends = 4.25" wide x 0.054" (1.37mm) 50 ksi (340 MPa)																																																																				
<input type="checkbox"/>	Reduced section strap -- fuse = 4" wide x 30" long -- ends = 6" wide x 0.068" (1.73mm) 50 ksi (340 MPa)																																																																				
<input type="checkbox"/>	Reduced section strap -- fuse = 2.5" wide x 60" long -- ends = 3.75" wide x 0.043" (1.09mm) 33 ksi (230 MPa)																																																																				
<input type="checkbox"/>	Reduced section strap -- fuse = 4" wide x 60" long -- ends = 6" wide x 0.068" (1.73mm) 50 ksi (340 MPa)																																																																				
INTERIOR STUDS:	<table border="1" style="width:100%; border-collapse: collapse;"> <tr><td><input checked="" type="checkbox"/></td><td>3-5/8"Wx1-5/8"Fx1/2"Lip 0.043" (1.09mm) 33ksi (230 Mpa)</td></tr> <tr><td><input type="checkbox"/></td><td>6"Wx1-5/8"Fx1/2"Lip 0.043" (1.09mm) 33ksi (230 Mpa)</td></tr> </table>		<input checked="" type="checkbox"/>	3-5/8"Wx1-5/8"Fx1/2"Lip 0.043" (1.09mm) 33ksi (230 Mpa)	<input type="checkbox"/>	6"Wx1-5/8"Fx1/2"Lip 0.043" (1.09mm) 33ksi (230 Mpa)	STUD SPACING:	<table border="1" style="width:100%; border-collapse: collapse;"> <tr><td><input checked="" type="checkbox"/></td><td>16" O.C.</td></tr> <tr><td><input type="checkbox"/></td><td>Other: _____</td></tr> </table>	<input checked="" type="checkbox"/>	16" O.C.	<input type="checkbox"/>	Other: _____																																																									
<input checked="" type="checkbox"/>	3-5/8"Wx1-5/8"Fx1/2"Lip 0.043" (1.09mm) 33ksi (230 Mpa)																																																																				
<input type="checkbox"/>	6"Wx1-5/8"Fx1/2"Lip 0.043" (1.09mm) 33ksi (230 Mpa)																																																																				
<input checked="" type="checkbox"/>	16" O.C.																																																																				
<input type="checkbox"/>	Other: _____																																																																				
BACK-TO-BACK CHORD STUDS:	<table border="1" style="width:100%; border-collapse: collapse;"> <tr><td><input checked="" type="checkbox"/></td><td>3-5/8"Wx1-5/8"Fx1/2"Lip 0.043" (1.09mm) 33ksi (230 Mpa)</td></tr> <tr><td><input type="checkbox"/></td><td>6"Wx1-5/8"Fx1/2"Lip 0.054" (1.37mm) 50ksi (345 Mpa)</td></tr> <tr><td><input type="checkbox"/></td><td>6"Wx1-5/8"Fx1/2"Lip 0.068" (1.73mm) 50ksi (345 Mpa)</td></tr> </table>			<input checked="" type="checkbox"/>	3-5/8"Wx1-5/8"Fx1/2"Lip 0.043" (1.09mm) 33ksi (230 Mpa)	<input type="checkbox"/>	6"Wx1-5/8"Fx1/2"Lip 0.054" (1.37mm) 50ksi (345 Mpa)	<input type="checkbox"/>	6"Wx1-5/8"Fx1/2"Lip 0.068" (1.73mm) 50ksi (345 Mpa)																																																												
<input checked="" type="checkbox"/>	3-5/8"Wx1-5/8"Fx1/2"Lip 0.043" (1.09mm) 33ksi (230 Mpa)																																																																				
<input type="checkbox"/>	6"Wx1-5/8"Fx1/2"Lip 0.054" (1.37mm) 50ksi (345 Mpa)																																																																				
<input type="checkbox"/>	6"Wx1-5/8"Fx1/2"Lip 0.068" (1.73mm) 50ksi (345 Mpa)																																																																				
CONNECTIONS:	<table border="1" style="width:100%; border-collapse: collapse;"> <tr><td>Straps</td><td><input checked="" type="checkbox"/></td><td>No.10 gauge 0.75" self-drilling water head (mod. Truss) Phillips drive</td></tr> <tr><td>Framing:</td><td><input checked="" type="checkbox"/></td><td>No.8 gauge 0.5" self-drilling water head (mod. Truss) Phillips drive</td></tr> <tr><td>Hold downs:</td><td><input checked="" type="checkbox"/></td><td>No.14 gauge 3/4" self-drilling Hex washer head</td></tr> <tr><td>Back-to-Back</td><td><input type="checkbox"/></td><td></td></tr> <tr><td>Chord Studs:</td><td><input checked="" type="checkbox"/></td><td>No.10 gauge 0.75" self-drilling Hex washer head</td></tr> <tr><td>Anchor Rods</td><td><input checked="" type="checkbox"/></td><td>7/8" A307</td></tr> <tr><td></td><td><input type="checkbox"/></td><td>1" Rod</td></tr> <tr><td>Loading Beam:</td><td><input checked="" type="checkbox"/></td><td>A325 3/4" bolts</td></tr> <tr><td>Base</td><td><input checked="" type="checkbox"/></td><td>A325 3/4" bolts</td></tr> <tr><td></td><td>12 bolts</td><td><input checked="" type="checkbox"/></td></tr> <tr><td></td><td>8 bolts</td><td><input checked="" type="checkbox"/></td></tr> <tr><td></td><td>2 Anchor Rods</td><td><input checked="" type="checkbox"/></td></tr> <tr><td></td><td>2 Anchor Rods</td><td><input checked="" type="checkbox"/></td></tr> </table>			Straps	<input checked="" type="checkbox"/>	No.10 gauge 0.75" self-drilling water head (mod. Truss) Phillips drive	Framing:	<input checked="" type="checkbox"/>	No.8 gauge 0.5" self-drilling water head (mod. Truss) Phillips drive	Hold downs:	<input checked="" type="checkbox"/>	No.14 gauge 3/4" self-drilling Hex washer head	Back-to-Back	<input type="checkbox"/>		Chord Studs:	<input checked="" type="checkbox"/>	No.10 gauge 0.75" self-drilling Hex washer head	Anchor Rods	<input checked="" type="checkbox"/>	7/8" A307		<input type="checkbox"/>	1" Rod	Loading Beam:	<input checked="" type="checkbox"/>	A325 3/4" bolts	Base	<input checked="" type="checkbox"/>	A325 3/4" bolts		12 bolts	<input checked="" type="checkbox"/>		8 bolts	<input checked="" type="checkbox"/>		2 Anchor Rods	<input checked="" type="checkbox"/>		2 Anchor Rods	<input checked="" type="checkbox"/>																											
Straps	<input checked="" type="checkbox"/>	No.10 gauge 0.75" self-drilling water head (mod. Truss) Phillips drive																																																																			
Framing:	<input checked="" type="checkbox"/>	No.8 gauge 0.5" self-drilling water head (mod. Truss) Phillips drive																																																																			
Hold downs:	<input checked="" type="checkbox"/>	No.14 gauge 3/4" self-drilling Hex washer head																																																																			
Back-to-Back	<input type="checkbox"/>																																																																				
Chord Studs:	<input checked="" type="checkbox"/>	No.10 gauge 0.75" self-drilling Hex washer head																																																																			
Anchor Rods	<input checked="" type="checkbox"/>	7/8" A307																																																																			
	<input type="checkbox"/>	1" Rod																																																																			
Loading Beam:	<input checked="" type="checkbox"/>	A325 3/4" bolts																																																																			
Base	<input checked="" type="checkbox"/>	A325 3/4" bolts																																																																			
	12 bolts	<input checked="" type="checkbox"/>																																																																			
	8 bolts	<input checked="" type="checkbox"/>																																																																			
	2 Anchor Rods	<input checked="" type="checkbox"/>																																																																			
	2 Anchor Rods	<input checked="" type="checkbox"/>																																																																			
TRACK:	<table border="1" style="width:100%; border-collapse: collapse;"> <tr><td><input type="checkbox"/></td><td>Regular</td><td><input type="checkbox"/></td><td>6" web</td><td><input checked="" type="checkbox"/></td><td>0.043" (1.09mm) 33ksi (230 Mpa)</td></tr> <tr><td><input checked="" type="checkbox"/></td><td>Extended</td><td><input checked="" type="checkbox"/></td><td>3 5/8" web</td><td><input type="checkbox"/></td><td>0.054" (1.37mm) 50ksi (345 Mpa)</td></tr> <tr><td><input type="checkbox"/></td><td>Reinforced</td><td><input type="checkbox"/></td><td>1-1/4" flange</td><td><input type="checkbox"/></td><td>0.068" (1.73mm) 50ksi (345 Mpa)</td></tr> </table>			<input type="checkbox"/>	Regular	<input type="checkbox"/>	6" web	<input checked="" type="checkbox"/>	0.043" (1.09mm) 33ksi (230 Mpa)	<input checked="" type="checkbox"/>	Extended	<input checked="" type="checkbox"/>	3 5/8" web	<input type="checkbox"/>	0.054" (1.37mm) 50ksi (345 Mpa)	<input type="checkbox"/>	Reinforced	<input type="checkbox"/>	1-1/4" flange	<input type="checkbox"/>	0.068" (1.73mm) 50ksi (345 Mpa)																																																
<input type="checkbox"/>	Regular	<input type="checkbox"/>	6" web	<input checked="" type="checkbox"/>	0.043" (1.09mm) 33ksi (230 Mpa)																																																																
<input checked="" type="checkbox"/>	Extended	<input checked="" type="checkbox"/>	3 5/8" web	<input type="checkbox"/>	0.054" (1.37mm) 50ksi (345 Mpa)																																																																
<input type="checkbox"/>	Reinforced	<input type="checkbox"/>	1-1/4" flange	<input type="checkbox"/>	0.068" (1.73mm) 50ksi (345 Mpa)																																																																
HOLD DOWNS:	<table border="1" style="width:100%; border-collapse: collapse;"> <tr><td><input checked="" type="checkbox"/></td><td>S/HD10S Simpson</td><td></td><td></td><td></td><td></td></tr> <tr><td><input type="checkbox"/></td><td>Fabricated U-shape</td><td></td><td></td><td></td><td></td></tr> <tr><td><input type="checkbox"/></td><td>6" x 6" 0.054" (1.37mm) 50 ksi (340 MPa) Gusset Plate w/ S/HD15S Simpson</td><td></td><td></td><td></td><td></td></tr> <tr><td><input type="checkbox"/></td><td>7" x 9" 0.054" (1.37mm) 50 ksi (340 MPa) Gusset Plate w/ S/HD15S Simpson</td><td></td><td></td><td></td><td></td></tr> <tr><td><input type="checkbox"/></td><td>8" x 8" 0.068" (1.73mm) 50 ksi (340 MPa) Gusset Plate w/ S/HD15S Simpson</td><td></td><td></td><td></td><td></td></tr> <tr><td><input type="checkbox"/></td><td>8.5" x10" 0.068" (1.73mm) 50 ksi (340 MPa) Gusset Plate w/ S/HD15S Simpson</td><td></td><td></td><td></td><td></td></tr> <tr><td><input type="checkbox"/></td><td>10" x10" 0.054" (1.37mm) 50 ksi (340 MPa) Gusset Plate w/ S/HD15S Simpson</td><td></td><td></td><td></td><td></td></tr> </table> <table border="1" style="width:100%; border-collapse: collapse; margin-top: 5px;"> <tr><td></td><td style="text-align: center;">inside</td><td style="text-align: center;">outside</td><td style="text-align: center;">raised</td></tr> <tr><td></td><td style="text-align: center;"><input checked="" type="checkbox"/></td><td style="text-align: center;"><input type="checkbox"/></td><td style="text-align: center;"><input type="checkbox"/></td></tr> <tr><td></td><td style="text-align: center;"><input type="checkbox"/></td><td style="text-align: center;"><input type="checkbox"/></td><td style="text-align: center;"><input type="checkbox"/></td></tr> <tr><td></td><td style="text-align: center;"><input type="checkbox"/></td><td style="text-align: center;"><input type="checkbox"/></td><td style="text-align: center;"><input type="checkbox"/></td></tr> <tr><td></td><td style="text-align: center;"><input type="checkbox"/></td><td style="text-align: center;"><input type="checkbox"/></td><td style="text-align: center;"><input type="checkbox"/></td></tr> <tr><td></td><td style="text-align: center;"><input type="checkbox"/></td><td style="text-align: center;"><input type="checkbox"/></td><td style="text-align: center;"><input type="checkbox"/></td></tr> </table>			<input checked="" type="checkbox"/>	S/HD10S Simpson					<input type="checkbox"/>	Fabricated U-shape					<input type="checkbox"/>	6" x 6" 0.054" (1.37mm) 50 ksi (340 MPa) Gusset Plate w/ S/HD15S Simpson					<input type="checkbox"/>	7" x 9" 0.054" (1.37mm) 50 ksi (340 MPa) Gusset Plate w/ S/HD15S Simpson					<input type="checkbox"/>	8" x 8" 0.068" (1.73mm) 50 ksi (340 MPa) Gusset Plate w/ S/HD15S Simpson					<input type="checkbox"/>	8.5" x10" 0.068" (1.73mm) 50 ksi (340 MPa) Gusset Plate w/ S/HD15S Simpson					<input type="checkbox"/>	10" x10" 0.054" (1.37mm) 50 ksi (340 MPa) Gusset Plate w/ S/HD15S Simpson						inside	outside	raised		<input checked="" type="checkbox"/>	<input type="checkbox"/>	<input type="checkbox"/>		<input type="checkbox"/>	<input type="checkbox"/>	<input type="checkbox"/>		<input type="checkbox"/>	<input type="checkbox"/>	<input type="checkbox"/>		<input type="checkbox"/>	<input type="checkbox"/>	<input type="checkbox"/>		<input type="checkbox"/>	<input type="checkbox"/>	<input type="checkbox"/>
<input checked="" type="checkbox"/>	S/HD10S Simpson																																																																				
<input type="checkbox"/>	Fabricated U-shape																																																																				
<input type="checkbox"/>	6" x 6" 0.054" (1.37mm) 50 ksi (340 MPa) Gusset Plate w/ S/HD15S Simpson																																																																				
<input type="checkbox"/>	7" x 9" 0.054" (1.37mm) 50 ksi (340 MPa) Gusset Plate w/ S/HD15S Simpson																																																																				
<input type="checkbox"/>	8" x 8" 0.068" (1.73mm) 50 ksi (340 MPa) Gusset Plate w/ S/HD15S Simpson																																																																				
<input type="checkbox"/>	8.5" x10" 0.068" (1.73mm) 50 ksi (340 MPa) Gusset Plate w/ S/HD15S Simpson																																																																				
<input type="checkbox"/>	10" x10" 0.054" (1.37mm) 50 ksi (340 MPa) Gusset Plate w/ S/HD15S Simpson																																																																				
	inside	outside	raised																																																																		
	<input checked="" type="checkbox"/>	<input type="checkbox"/>	<input type="checkbox"/>																																																																		
	<input type="checkbox"/>	<input type="checkbox"/>	<input type="checkbox"/>																																																																		
	<input type="checkbox"/>	<input type="checkbox"/>	<input type="checkbox"/>																																																																		
	<input type="checkbox"/>	<input type="checkbox"/>	<input type="checkbox"/>																																																																		
	<input type="checkbox"/>	<input type="checkbox"/>	<input type="checkbox"/>																																																																		
TEST PROTOCOL AND DESCRIPTION:	<table border="1" style="width:100%; border-collapse: collapse;"> <tr><td><input type="checkbox"/></td><td>Monotonic (Rate of Loading 2.5 mm/min)</td></tr> <tr><td><input checked="" type="checkbox"/></td><td>Cyclic (CUREE cyclic protocol)</td></tr> </table>			<input type="checkbox"/>	Monotonic (Rate of Loading 2.5 mm/min)	<input checked="" type="checkbox"/>	Cyclic (CUREE cyclic protocol)																																																														
<input type="checkbox"/>	Monotonic (Rate of Loading 2.5 mm/min)																																																																				
<input checked="" type="checkbox"/>	Cyclic (CUREE cyclic protocol)																																																																				
LVDT MEASUREMENTS:	<table border="1" style="width:100%; border-collapse: collapse;"> <tr><td><input checked="" type="checkbox"/></td><td>Actuator LVDT</td><td><input checked="" type="checkbox"/></td><td>North Uplift</td></tr> <tr><td><input checked="" type="checkbox"/></td><td>North Slip</td><td><input checked="" type="checkbox"/></td><td>South Uplift</td></tr> <tr><td><input checked="" type="checkbox"/></td><td>South Slip</td><td><input checked="" type="checkbox"/></td><td>Top of Wall</td></tr> </table>			<input checked="" type="checkbox"/>	Actuator LVDT	<input checked="" type="checkbox"/>	North Uplift	<input checked="" type="checkbox"/>	North Slip	<input checked="" type="checkbox"/>	South Uplift	<input checked="" type="checkbox"/>	South Slip	<input checked="" type="checkbox"/>	Top of Wall																																																						
<input checked="" type="checkbox"/>	Actuator LVDT	<input checked="" type="checkbox"/>	North Uplift																																																																		
<input checked="" type="checkbox"/>	North Slip	<input checked="" type="checkbox"/>	South Uplift																																																																		
<input checked="" type="checkbox"/>	South Slip	<input checked="" type="checkbox"/>	Top of Wall																																																																		
TOTAL: <input type="checkbox"/> 6																																																																					
STRAP WIDTH BEFORE TEST:	<table border="1" style="width:100%; border-collapse: collapse;"> <tr><td>Front Right</td><td>63.38</td><td>Front Left, mm</td><td>63.74</td><td>Back Right, mm</td><td>63.89</td><td>Back Left, mm</td><td>63.19</td></tr> <tr><td></td><td>63.47</td><td></td><td>63.72</td><td></td><td>63.64</td><td></td><td>63.54</td></tr> <tr><td></td><td>63.92</td><td></td><td>63.81</td><td></td><td>63.81</td><td></td><td>63.17</td></tr> <tr><td>AVG</td><td>63.59</td><td>AVG</td><td>63.76 mm</td><td>AVG</td><td>63.78 mm</td><td>AVG</td><td>63.30 mm</td></tr> </table>			Front Right	63.38	Front Left, mm	63.74	Back Right, mm	63.89	Back Left, mm	63.19		63.47		63.72		63.64		63.54		63.92		63.81		63.81		63.17	AVG	63.59	AVG	63.76 mm	AVG	63.78 mm	AVG	63.30 mm																																		
Front Right	63.38	Front Left, mm	63.74	Back Right, mm	63.89	Back Left, mm	63.19																																																														
	63.47		63.72		63.64		63.54																																																														
	63.92		63.81		63.81		63.17																																																														
AVG	63.59	AVG	63.76 mm	AVG	63.78 mm	AVG	63.30 mm																																																														
DATA ACQ. RECORD RATE:	100 scan/sec		MONITOR RATE:	100 scan/sec																																																																	
COMMENTS:	<ul style="list-style-type: none"> -Shear anchors torqued for 10 s with impact wrench -Hold down anchors 1/2 turn from finger tight (load cells used on both hold-downs) -Ambient temperature 28 C -Double chord studs used screwed back to back -Square plate washers (2.5"x2.5") used in all top track connections -Regular washers used in all bottom track connections 																																																																				

Figure C. 3 Data sheet for test 26 A-C

Cold Formed Steel Strap Braced Walls McGill University, Montreal																																										
TEST:	27 A-M																																									
RESEARCHER:	Kostadin Velchev	ASSISTANTS:	Gilles Comeau, Nisreen Balh																																							
DATE:	July 3, 2007		TIME:	10:28																																						
DIMENSIONS OF WALL:	8 FT X	8 FT X	6 IN.	INITIAL STRAP SURVEY:	Front Back	Right tight tight	Left tight tight																																			
STRAP FASTENER CONFIGURATION:				MFR:	McGill																																					
STRAP SIZE:	<table border="0" style="width:100%;"> <tr><td><input type="checkbox"/></td><td>2.5" 0.043" (1.09mm) 33 ksi (230 MPa)</td></tr> <tr><td><input checked="" type="checkbox"/></td><td>2.75" 0.054" (1.37mm) 50 ksi (340 MPa)</td></tr> <tr><td><input type="checkbox"/></td><td>4" 0.068" (1.73mm) 50 ksi (340 MPa)</td></tr> <tr><td><input type="checkbox"/></td><td>5" 0.043" (1.09) 33 ksi (230 MPa)</td></tr> <tr><td><input type="checkbox"/></td><td>Reduced section strap -- fuse = 2.5" wide x 30" long -- ends = 3.75" wide 0.043" (1.09mm) 33 ksi (230 MPa)</td></tr> <tr><td><input type="checkbox"/></td><td>Reduced section strap -- fuse = 2.75" wide x 30" long -- ends = 4.25" wide 0.054" (1.37mm) 50 ksi (340 MPa)</td></tr> <tr><td><input type="checkbox"/></td><td>Reduced section strap -- fuse = 4" wide x 30" long -- ends = 6" wide 0.068" (1.73mm) 50 ksi (340 MPa)</td></tr> <tr><td><input type="checkbox"/></td><td>Reduced section strap -- fuse = 2.5" wide x 60" long -- ends = 3.75" wide 0.043" (1.09mm) 33 ksi (230 MPa)</td></tr> <tr><td><input type="checkbox"/></td><td>Reduced section strap -- fuse = 4" wide x 60" long -- ends = 6" wide 0.068" (1.73mm) 50 ksi (340 MPa)</td></tr> </table>							<input type="checkbox"/>	2.5" 0.043" (1.09mm) 33 ksi (230 MPa)	<input checked="" type="checkbox"/>	2.75" 0.054" (1.37mm) 50 ksi (340 MPa)	<input type="checkbox"/>	4" 0.068" (1.73mm) 50 ksi (340 MPa)	<input type="checkbox"/>	5" 0.043" (1.09) 33 ksi (230 MPa)	<input type="checkbox"/>	Reduced section strap -- fuse = 2.5" wide x 30" long -- ends = 3.75" wide 0.043" (1.09mm) 33 ksi (230 MPa)	<input type="checkbox"/>	Reduced section strap -- fuse = 2.75" wide x 30" long -- ends = 4.25" wide 0.054" (1.37mm) 50 ksi (340 MPa)	<input type="checkbox"/>	Reduced section strap -- fuse = 4" wide x 30" long -- ends = 6" wide 0.068" (1.73mm) 50 ksi (340 MPa)	<input type="checkbox"/>	Reduced section strap -- fuse = 2.5" wide x 60" long -- ends = 3.75" wide 0.043" (1.09mm) 33 ksi (230 MPa)	<input type="checkbox"/>	Reduced section strap -- fuse = 4" wide x 60" long -- ends = 6" wide 0.068" (1.73mm) 50 ksi (340 MPa)																	
<input type="checkbox"/>	2.5" 0.043" (1.09mm) 33 ksi (230 MPa)																																									
<input checked="" type="checkbox"/>	2.75" 0.054" (1.37mm) 50 ksi (340 MPa)																																									
<input type="checkbox"/>	4" 0.068" (1.73mm) 50 ksi (340 MPa)																																									
<input type="checkbox"/>	5" 0.043" (1.09) 33 ksi (230 MPa)																																									
<input type="checkbox"/>	Reduced section strap -- fuse = 2.5" wide x 30" long -- ends = 3.75" wide 0.043" (1.09mm) 33 ksi (230 MPa)																																									
<input type="checkbox"/>	Reduced section strap -- fuse = 2.75" wide x 30" long -- ends = 4.25" wide 0.054" (1.37mm) 50 ksi (340 MPa)																																									
<input type="checkbox"/>	Reduced section strap -- fuse = 4" wide x 30" long -- ends = 6" wide 0.068" (1.73mm) 50 ksi (340 MPa)																																									
<input type="checkbox"/>	Reduced section strap -- fuse = 2.5" wide x 60" long -- ends = 3.75" wide 0.043" (1.09mm) 33 ksi (230 MPa)																																									
<input type="checkbox"/>	Reduced section strap -- fuse = 4" wide x 60" long -- ends = 6" wide 0.068" (1.73mm) 50 ksi (340 MPa)																																									
INTERIOR STUDS:	<input type="checkbox"/> 3-5/8"Wx1-5/8"Fx1/2"Lip 0.043" (1.09mm) 33ksi (230 Mpa) <input checked="" type="checkbox"/> 6"Wx1-5/8"Fx1/2"Lip 0.043" (1.09mm) 33ksi (230 Mpa)		STUD SPACING:	<input checked="" type="checkbox"/> 16" O.C. <input type="checkbox"/> Other : _____																																						
BACK-TO-BACK CHORD STUDS:	<input type="checkbox"/> 3-5/8"Wx1-5/8"Fx1/2"Lip 0.043" (1.09mm) 33ksi (230 Mpa) <input checked="" type="checkbox"/> 6"Wx1-5/8"Fx1/2"Lip 0.054" (1.37mm) 50ksi (345 Mpa) <input type="checkbox"/> 6"Wx1-5/8"Fx1/2"Lip 0.068" (1.73mm) 50ksi (345 Mpa)																																									
CONNECTIONS:	<table border="0" style="width:100%;"> <tr><td>Straps:</td><td><input checked="" type="checkbox"/></td><td>No.10 gauge 0.75" self-drilling wafer head (mod. Truss) Phillips drive</td></tr> <tr><td>Framing:</td><td><input checked="" type="checkbox"/></td><td>No.8 gauge 0.5" self-drilling wafer head (mod. Truss) Phillips drive</td></tr> <tr><td>Hold downs:</td><td><input checked="" type="checkbox"/></td><td>No.14 gauge 1" self-drilling Hex washer head</td></tr> <tr><td>Back-to-Back:</td><td><input checked="" type="checkbox"/></td><td>No.14 gauge 1" self-drilling Hex washer head</td></tr> <tr><td>Chord Studs:</td><td><input checked="" type="checkbox"/></td><td>No.10 gauge 1" self-drilling Hex washer head</td></tr> <tr><td>Anchor Rods:</td><td><input type="checkbox"/></td><td>7/8" A307</td></tr> <tr><td></td><td><input checked="" type="checkbox"/></td><td>1" Rod</td></tr> <tr><td>Loading Beam:</td><td><input checked="" type="checkbox"/></td><td>A325 3/4" bolts</td></tr> <tr><td>Base:</td><td><input checked="" type="checkbox"/></td><td>A325 3/4" bolts</td></tr> </table> <table border="0" style="width:100%; margin-top: 5px;"> <tr> <td>12 bolts</td><td><input checked="" type="checkbox"/></td> <td>2 Anchor Rods</td><td><input checked="" type="checkbox"/></td> </tr> <tr> <td>8 bolts</td><td><input checked="" type="checkbox"/></td> <td>2 Anchor Rods</td><td><input checked="" type="checkbox"/></td> </tr> </table>							Straps:	<input checked="" type="checkbox"/>	No.10 gauge 0.75" self-drilling wafer head (mod. Truss) Phillips drive	Framing:	<input checked="" type="checkbox"/>	No.8 gauge 0.5" self-drilling wafer head (mod. Truss) Phillips drive	Hold downs:	<input checked="" type="checkbox"/>	No.14 gauge 1" self-drilling Hex washer head	Back-to-Back:	<input checked="" type="checkbox"/>	No.14 gauge 1" self-drilling Hex washer head	Chord Studs:	<input checked="" type="checkbox"/>	No.10 gauge 1" self-drilling Hex washer head	Anchor Rods:	<input type="checkbox"/>	7/8" A307		<input checked="" type="checkbox"/>	1" Rod	Loading Beam:	<input checked="" type="checkbox"/>	A325 3/4" bolts	Base:	<input checked="" type="checkbox"/>	A325 3/4" bolts	12 bolts	<input checked="" type="checkbox"/>	2 Anchor Rods	<input checked="" type="checkbox"/>	8 bolts	<input checked="" type="checkbox"/>	2 Anchor Rods	<input checked="" type="checkbox"/>
Straps:	<input checked="" type="checkbox"/>	No.10 gauge 0.75" self-drilling wafer head (mod. Truss) Phillips drive																																								
Framing:	<input checked="" type="checkbox"/>	No.8 gauge 0.5" self-drilling wafer head (mod. Truss) Phillips drive																																								
Hold downs:	<input checked="" type="checkbox"/>	No.14 gauge 1" self-drilling Hex washer head																																								
Back-to-Back:	<input checked="" type="checkbox"/>	No.14 gauge 1" self-drilling Hex washer head																																								
Chord Studs:	<input checked="" type="checkbox"/>	No.10 gauge 1" self-drilling Hex washer head																																								
Anchor Rods:	<input type="checkbox"/>	7/8" A307																																								
	<input checked="" type="checkbox"/>	1" Rod																																								
Loading Beam:	<input checked="" type="checkbox"/>	A325 3/4" bolts																																								
Base:	<input checked="" type="checkbox"/>	A325 3/4" bolts																																								
12 bolts	<input checked="" type="checkbox"/>	2 Anchor Rods	<input checked="" type="checkbox"/>																																							
8 bolts	<input checked="" type="checkbox"/>	2 Anchor Rods	<input checked="" type="checkbox"/>																																							
TRACK:	<table border="0" style="width:100%;"> <tr> <td><input type="checkbox"/></td><td>Regular</td> <td><input checked="" type="checkbox"/></td><td>6" web</td> <td><input type="checkbox"/></td><td>0.043" (1.09mm) 33ksi (230 Mpa)</td> </tr> <tr> <td><input checked="" type="checkbox"/></td><td>Extended</td> <td><input type="checkbox"/></td><td>3 5/8" web</td> <td><input checked="" type="checkbox"/></td><td>0.054" (1.37mm) 50ksi (345 Mpa)</td> </tr> <tr> <td><input type="checkbox"/></td><td>Reinforced</td> <td><input type="checkbox"/></td><td>1-1/4" flange</td> <td><input type="checkbox"/></td><td>0.068" (1.73mm) 50ksi (345 Mpa)</td> </tr> </table>							<input type="checkbox"/>	Regular	<input checked="" type="checkbox"/>	6" web	<input type="checkbox"/>	0.043" (1.09mm) 33ksi (230 Mpa)	<input checked="" type="checkbox"/>	Extended	<input type="checkbox"/>	3 5/8" web	<input checked="" type="checkbox"/>	0.054" (1.37mm) 50ksi (345 Mpa)	<input type="checkbox"/>	Reinforced	<input type="checkbox"/>	1-1/4" flange	<input type="checkbox"/>	0.068" (1.73mm) 50ksi (345 Mpa)																	
<input type="checkbox"/>	Regular	<input checked="" type="checkbox"/>	6" web	<input type="checkbox"/>	0.043" (1.09mm) 33ksi (230 Mpa)																																					
<input checked="" type="checkbox"/>	Extended	<input type="checkbox"/>	3 5/8" web	<input checked="" type="checkbox"/>	0.054" (1.37mm) 50ksi (345 Mpa)																																					
<input type="checkbox"/>	Reinforced	<input type="checkbox"/>	1-1/4" flange	<input type="checkbox"/>	0.068" (1.73mm) 50ksi (345 Mpa)																																					
HOLD DOWNS:	<table border="0" style="width:100%;"> <tr> <td><input type="checkbox"/></td><td>S/HD10S Simpson</td> <td rowspan="6" style="text-align: center;"> <table border="1" style="border-collapse: collapse;"> <tr><th>inside</th><th>outside</th><th>raised</th></tr> <tr><td><input type="checkbox"/></td><td><input type="checkbox"/></td><td><input type="checkbox"/></td></tr> <tr><td><input type="checkbox"/></td><td><input type="checkbox"/></td><td><input type="checkbox"/></td></tr> <tr><td><input checked="" type="checkbox"/></td><td><input checked="" type="checkbox"/></td><td><input type="checkbox"/></td></tr> <tr><td><input type="checkbox"/></td><td><input type="checkbox"/></td><td><input type="checkbox"/></td></tr> <tr><td><input type="checkbox"/></td><td><input type="checkbox"/></td><td><input type="checkbox"/></td></tr> </table> </td> </tr> <tr><td><input type="checkbox"/></td><td>Fabricated U-shape</td></tr> <tr><td><input type="checkbox"/></td><td>6" x 6" 0.054" (1.37mm) 50 ksi (340 MPa) Gusset Plate w/ S/HD15S Simpson</td></tr> <tr><td><input checked="" type="checkbox"/></td><td>7" x 9" 0.054" (1.37mm) 50 ksi (340 MPa) Gusset Plate w/ S/HD15S Simpson</td></tr> <tr><td><input type="checkbox"/></td><td>8" x 8" 0.068" (1.73mm) 50 ksi (340 MPa) Gusset Plate w/ S/HD15S Simpson</td></tr> <tr><td><input type="checkbox"/></td><td>8.5" x 10" 0.068" (1.73mm) 50 ksi (340 MPa) Gusset Plate w/ S/HD15S Simpson</td></tr> <tr><td><input type="checkbox"/></td><td>10" x 10" 0.054" (1.37mm) 50 ksi (340 MPa) Gusset Plate w/ S/HD15S Simpson</td></tr> </table>							<input type="checkbox"/>	S/HD10S Simpson	<table border="1" style="border-collapse: collapse;"> <tr><th>inside</th><th>outside</th><th>raised</th></tr> <tr><td><input type="checkbox"/></td><td><input type="checkbox"/></td><td><input type="checkbox"/></td></tr> <tr><td><input type="checkbox"/></td><td><input type="checkbox"/></td><td><input type="checkbox"/></td></tr> <tr><td><input checked="" type="checkbox"/></td><td><input checked="" type="checkbox"/></td><td><input type="checkbox"/></td></tr> <tr><td><input type="checkbox"/></td><td><input type="checkbox"/></td><td><input type="checkbox"/></td></tr> <tr><td><input type="checkbox"/></td><td><input type="checkbox"/></td><td><input type="checkbox"/></td></tr> </table>	inside	outside	raised	<input type="checkbox"/>	<input type="checkbox"/>	<input type="checkbox"/>	<input type="checkbox"/>	<input type="checkbox"/>	<input type="checkbox"/>	<input checked="" type="checkbox"/>	<input checked="" type="checkbox"/>	<input type="checkbox"/>	<input type="checkbox"/>	<input type="checkbox"/>	<input type="checkbox"/>	<input type="checkbox"/>	<input type="checkbox"/>	<input type="checkbox"/>	<input type="checkbox"/>	Fabricated U-shape	<input type="checkbox"/>	6" x 6" 0.054" (1.37mm) 50 ksi (340 MPa) Gusset Plate w/ S/HD15S Simpson	<input checked="" type="checkbox"/>	7" x 9" 0.054" (1.37mm) 50 ksi (340 MPa) Gusset Plate w/ S/HD15S Simpson	<input type="checkbox"/>	8" x 8" 0.068" (1.73mm) 50 ksi (340 MPa) Gusset Plate w/ S/HD15S Simpson	<input type="checkbox"/>	8.5" x 10" 0.068" (1.73mm) 50 ksi (340 MPa) Gusset Plate w/ S/HD15S Simpson	<input type="checkbox"/>	10" x 10" 0.054" (1.37mm) 50 ksi (340 MPa) Gusset Plate w/ S/HD15S Simpson		
<input type="checkbox"/>	S/HD10S Simpson	<table border="1" style="border-collapse: collapse;"> <tr><th>inside</th><th>outside</th><th>raised</th></tr> <tr><td><input type="checkbox"/></td><td><input type="checkbox"/></td><td><input type="checkbox"/></td></tr> <tr><td><input type="checkbox"/></td><td><input type="checkbox"/></td><td><input type="checkbox"/></td></tr> <tr><td><input checked="" type="checkbox"/></td><td><input checked="" type="checkbox"/></td><td><input type="checkbox"/></td></tr> <tr><td><input type="checkbox"/></td><td><input type="checkbox"/></td><td><input type="checkbox"/></td></tr> <tr><td><input type="checkbox"/></td><td><input type="checkbox"/></td><td><input type="checkbox"/></td></tr> </table>	inside	outside	raised	<input type="checkbox"/>	<input type="checkbox"/>	<input type="checkbox"/>	<input type="checkbox"/>		<input type="checkbox"/>	<input type="checkbox"/>	<input checked="" type="checkbox"/>	<input checked="" type="checkbox"/>	<input type="checkbox"/>	<input type="checkbox"/>	<input type="checkbox"/>	<input type="checkbox"/>	<input type="checkbox"/>	<input type="checkbox"/>	<input type="checkbox"/>																					
inside	outside		raised																																							
<input type="checkbox"/>	<input type="checkbox"/>		<input type="checkbox"/>																																							
<input type="checkbox"/>	<input type="checkbox"/>		<input type="checkbox"/>																																							
<input checked="" type="checkbox"/>	<input checked="" type="checkbox"/>		<input type="checkbox"/>																																							
<input type="checkbox"/>	<input type="checkbox"/>		<input type="checkbox"/>																																							
<input type="checkbox"/>	<input type="checkbox"/>	<input type="checkbox"/>																																								
<input type="checkbox"/>	Fabricated U-shape																																									
<input type="checkbox"/>	6" x 6" 0.054" (1.37mm) 50 ksi (340 MPa) Gusset Plate w/ S/HD15S Simpson																																									
<input checked="" type="checkbox"/>	7" x 9" 0.054" (1.37mm) 50 ksi (340 MPa) Gusset Plate w/ S/HD15S Simpson																																									
<input type="checkbox"/>	8" x 8" 0.068" (1.73mm) 50 ksi (340 MPa) Gusset Plate w/ S/HD15S Simpson																																									
<input type="checkbox"/>	8.5" x 10" 0.068" (1.73mm) 50 ksi (340 MPa) Gusset Plate w/ S/HD15S Simpson																																									
<input type="checkbox"/>	10" x 10" 0.054" (1.37mm) 50 ksi (340 MPa) Gusset Plate w/ S/HD15S Simpson																																									
TEST PROTOCOL AND DESCRIPTION:	<input checked="" type="checkbox"/> Monotonic (Rate of Loading 2.5 mm/min) <input type="checkbox"/> Cyclic (CUREE cyclic protocol)																																									
LVDT MEASUREMENTS:	<table border="0" style="width:100%;"> <tr><td><input checked="" type="checkbox"/></td><td>Actuator LVDT</td><td><input checked="" type="checkbox"/></td><td>North Uplift</td></tr> <tr><td><input checked="" type="checkbox"/></td><td>North Slip</td><td><input checked="" type="checkbox"/></td><td>South Uplift</td></tr> <tr><td><input checked="" type="checkbox"/></td><td>South Slip</td><td><input checked="" type="checkbox"/></td><td>Top of Wall</td></tr> </table> <p style="text-align: right;">TOTAL: <input type="text" value="6"/></p>							<input checked="" type="checkbox"/>	Actuator LVDT	<input checked="" type="checkbox"/>	North Uplift	<input checked="" type="checkbox"/>	North Slip	<input checked="" type="checkbox"/>	South Uplift	<input checked="" type="checkbox"/>	South Slip	<input checked="" type="checkbox"/>	Top of Wall																							
<input checked="" type="checkbox"/>	Actuator LVDT	<input checked="" type="checkbox"/>	North Uplift																																							
<input checked="" type="checkbox"/>	North Slip	<input checked="" type="checkbox"/>	South Uplift																																							
<input checked="" type="checkbox"/>	South Slip	<input checked="" type="checkbox"/>	Top of Wall																																							
STRAP WIDTH BEFORE TEST:	<table border="0" style="width:100%;"> <tr> <td style="text-align: center;">Front Right</td> <td style="text-align: center;">Front Left, mm</td> <td style="text-align: center;">Back Right, mm</td> <td style="text-align: center;">Back Left, mm</td> </tr> <tr> <td style="text-align: center;">68.84</td> <td style="text-align: center;">70.44</td> <td style="text-align: center;">69.20</td> <td style="text-align: center;">69.97</td> </tr> <tr> <td style="text-align: center;">69.84</td> <td style="text-align: center;">70.04</td> <td style="text-align: center;">69.80</td> <td style="text-align: center;">69.90</td> </tr> <tr> <td style="text-align: center;">70.42</td> <td style="text-align: center;">69.90</td> <td style="text-align: center;">69.96</td> <td style="text-align: center;">69.83</td> </tr> <tr> <td style="text-align: center;">AVG</td> <td style="text-align: center;">69.70</td> <td style="text-align: center;">AVG</td> <td style="text-align: center;">69.65</td> </tr> <tr> <td></td> <td style="text-align: center;">70.13 mm</td> <td style="text-align: center;">AVG</td> <td style="text-align: center;">69.65 mm</td> </tr> <tr> <td></td> <td></td> <td style="text-align: center;">AVG</td> <td style="text-align: center;">69.90 mm</td> </tr> </table>							Front Right	Front Left, mm	Back Right, mm	Back Left, mm	68.84	70.44	69.20	69.97	69.84	70.04	69.80	69.90	70.42	69.90	69.96	69.83	AVG	69.70	AVG	69.65		70.13 mm	AVG	69.65 mm			AVG	69.90 mm							
Front Right	Front Left, mm	Back Right, mm	Back Left, mm																																							
68.84	70.44	69.20	69.97																																							
69.84	70.04	69.80	69.90																																							
70.42	69.90	69.96	69.83																																							
AVG	69.70	AVG	69.65																																							
	70.13 mm	AVG	69.65 mm																																							
		AVG	69.90 mm																																							
DATA ACQ. RECORD RATE:	1 scan/sec			MONITOR RATE:	10 scan/sec																																					
COMMENTS:	<ul style="list-style-type: none"> -Shear anchors torqued for 10 s with impact wrench -Hold down anchors 1/2 turn from finger tight (load cells used on both hold-downs) -Ambient temperature 26 C -Double chord studs used screwed back to back -Square plate washers (2.5"x2.5") used in all top track connections -Regular washers used in all bottom track connections 																																									

Figure C. 4 Data sheet for test 27 A-M

Cold Formed Steel Strap Braced Walls McGill University, Montreal																																						
TEST:	28 A-C																																					
RESEARCHER:	Kostadin Velchev	ASSISTANTS:	Gilles Comeau, Nisreen Balh																																			
DATE:	24-Jul-07	TIME:	13:35																																			
DIMENSIONS OF WALL:	8 FT X	8 FT X	6 IN.																																			
INITIAL STRAP SURVEY:	Front	Right	Left																																			
	Back	tight	loose																																			
		loose	tight																																			
STRAP FASTENER CONFIGURATION: MFR: McGill																																						
STRAP SIZE:	<table border="1" style="width:100%; border-collapse: collapse;"> <tr><td><input type="checkbox"/></td><td>2.5" 0.043" (1.09mm) 33 ksi (230 MPa)</td></tr> <tr><td><input checked="" type="checkbox"/></td><td>2.75" 0.054" (1.37mm) 50 ksi (340 MPa)</td></tr> <tr><td><input type="checkbox"/></td><td>4" 0.068" (1.73mm) 50 ksi (340 MPa)</td></tr> <tr><td><input type="checkbox"/></td><td>5" 0.043" (1.09) 33 ksi (230 MPa)</td></tr> <tr><td><input type="checkbox"/></td><td>Reduced section strap -- fuse = 2.5" wide x 30" long -- ends = 3.75" wide 0.043" (1.09mm) 33 ksi (230 MPa)</td></tr> <tr><td><input type="checkbox"/></td><td>Reduced section strap -- fuse = 2.75" wide x 30" long -- ends = 4.25" wide 0.054" (1.37mm) 50 ksi (340 MPa)</td></tr> <tr><td><input type="checkbox"/></td><td>Reduced section strap -- fuse = 4" wide x 30" long -- ends = 6" wide 0.068" (1.73mm) 50 ksi (340 MPa)</td></tr> <tr><td><input type="checkbox"/></td><td>Reduced section strap -- fuse = 2.5" wide x 60" long -- ends = 3.75" wide 0.043" (1.09mm) 33 ksi (230 MPa)</td></tr> <tr><td><input type="checkbox"/></td><td>Reduced section strap -- fuse = 4" wide x 60" long -- ends = 6" wide 0.068" (1.73mm) 50 ksi (340 MPa)</td></tr> </table>			<input type="checkbox"/>	2.5" 0.043" (1.09mm) 33 ksi (230 MPa)	<input checked="" type="checkbox"/>	2.75" 0.054" (1.37mm) 50 ksi (340 MPa)	<input type="checkbox"/>	4" 0.068" (1.73mm) 50 ksi (340 MPa)	<input type="checkbox"/>	5" 0.043" (1.09) 33 ksi (230 MPa)	<input type="checkbox"/>	Reduced section strap -- fuse = 2.5" wide x 30" long -- ends = 3.75" wide 0.043" (1.09mm) 33 ksi (230 MPa)	<input type="checkbox"/>	Reduced section strap -- fuse = 2.75" wide x 30" long -- ends = 4.25" wide 0.054" (1.37mm) 50 ksi (340 MPa)	<input type="checkbox"/>	Reduced section strap -- fuse = 4" wide x 30" long -- ends = 6" wide 0.068" (1.73mm) 50 ksi (340 MPa)	<input type="checkbox"/>	Reduced section strap -- fuse = 2.5" wide x 60" long -- ends = 3.75" wide 0.043" (1.09mm) 33 ksi (230 MPa)	<input type="checkbox"/>	Reduced section strap -- fuse = 4" wide x 60" long -- ends = 6" wide 0.068" (1.73mm) 50 ksi (340 MPa)																	
<input type="checkbox"/>	2.5" 0.043" (1.09mm) 33 ksi (230 MPa)																																					
<input checked="" type="checkbox"/>	2.75" 0.054" (1.37mm) 50 ksi (340 MPa)																																					
<input type="checkbox"/>	4" 0.068" (1.73mm) 50 ksi (340 MPa)																																					
<input type="checkbox"/>	5" 0.043" (1.09) 33 ksi (230 MPa)																																					
<input type="checkbox"/>	Reduced section strap -- fuse = 2.5" wide x 30" long -- ends = 3.75" wide 0.043" (1.09mm) 33 ksi (230 MPa)																																					
<input type="checkbox"/>	Reduced section strap -- fuse = 2.75" wide x 30" long -- ends = 4.25" wide 0.054" (1.37mm) 50 ksi (340 MPa)																																					
<input type="checkbox"/>	Reduced section strap -- fuse = 4" wide x 30" long -- ends = 6" wide 0.068" (1.73mm) 50 ksi (340 MPa)																																					
<input type="checkbox"/>	Reduced section strap -- fuse = 2.5" wide x 60" long -- ends = 3.75" wide 0.043" (1.09mm) 33 ksi (230 MPa)																																					
<input type="checkbox"/>	Reduced section strap -- fuse = 4" wide x 60" long -- ends = 6" wide 0.068" (1.73mm) 50 ksi (340 MPa)																																					
INTERIOR STUDS:	<table border="1" style="width:100%; border-collapse: collapse;"> <tr><td><input type="checkbox"/></td><td>3-5/8"Wx1-5/8"Fx1/2"Lip 0.043" (1.09mm) 33ksi (230 Mpa)</td></tr> <tr><td><input checked="" type="checkbox"/></td><td>6"Wx1-5/8"Fx1/2"Lip 0.043" (1.09mm) 33ksi (230 Mpa)</td></tr> </table>		<input type="checkbox"/>	3-5/8"Wx1-5/8"Fx1/2"Lip 0.043" (1.09mm) 33ksi (230 Mpa)	<input checked="" type="checkbox"/>	6"Wx1-5/8"Fx1/2"Lip 0.043" (1.09mm) 33ksi (230 Mpa)	STUD SPACING:	<table border="1" style="width:100%; border-collapse: collapse;"> <tr><td><input checked="" type="checkbox"/></td><td>16" O.C.</td></tr> <tr><td><input type="checkbox"/></td><td>Other: _____</td></tr> </table>	<input checked="" type="checkbox"/>	16" O.C.	<input type="checkbox"/>	Other: _____																										
<input type="checkbox"/>	3-5/8"Wx1-5/8"Fx1/2"Lip 0.043" (1.09mm) 33ksi (230 Mpa)																																					
<input checked="" type="checkbox"/>	6"Wx1-5/8"Fx1/2"Lip 0.043" (1.09mm) 33ksi (230 Mpa)																																					
<input checked="" type="checkbox"/>	16" O.C.																																					
<input type="checkbox"/>	Other: _____																																					
BACK-TO-BACK CHORD STUDS:	<table border="1" style="width:100%; border-collapse: collapse;"> <tr><td><input type="checkbox"/></td><td>3-5/8"Wx1-5/8"Fx1/2"Lip 0.043" (1.09mm) 33ksi (230 Mpa)</td></tr> <tr><td><input checked="" type="checkbox"/></td><td>6"Wx1-5/8"Fx1/2"Lip 0.054" (1.37mm) 50ksi (345 Mpa)</td></tr> <tr><td><input type="checkbox"/></td><td>6"Wx1-5/8"Fx1/2"Lip 0.068" (1.73mm) 50ksi (345 Mpa)</td></tr> </table>			<input type="checkbox"/>	3-5/8"Wx1-5/8"Fx1/2"Lip 0.043" (1.09mm) 33ksi (230 Mpa)	<input checked="" type="checkbox"/>	6"Wx1-5/8"Fx1/2"Lip 0.054" (1.37mm) 50ksi (345 Mpa)	<input type="checkbox"/>	6"Wx1-5/8"Fx1/2"Lip 0.068" (1.73mm) 50ksi (345 Mpa)																													
<input type="checkbox"/>	3-5/8"Wx1-5/8"Fx1/2"Lip 0.043" (1.09mm) 33ksi (230 Mpa)																																					
<input checked="" type="checkbox"/>	6"Wx1-5/8"Fx1/2"Lip 0.054" (1.37mm) 50ksi (345 Mpa)																																					
<input type="checkbox"/>	6"Wx1-5/8"Fx1/2"Lip 0.068" (1.73mm) 50ksi (345 Mpa)																																					
CONNECTIONS:	<table border="1" style="width:100%; border-collapse: collapse;"> <tr><td><input checked="" type="checkbox"/></td><td>Straps</td><td>No. 10 gauge 0.75" self-drilling wafer head (mod. Truss) Phillips drive</td></tr> <tr><td><input checked="" type="checkbox"/></td><td>Framing:</td><td>No. 8 gauge 0.5" self-drilling wafer head (mod. Truss) Phillips drive</td></tr> <tr><td><input type="checkbox"/></td><td>Hold downs:</td><td>No. 14 gauge 1" self-drilling Hex washer head</td></tr> <tr><td><input checked="" type="checkbox"/></td><td>Back-to-Back</td><td></td></tr> <tr><td><input checked="" type="checkbox"/></td><td>Chord Studs:</td><td>No. 10 gauge 1" self-drilling Hex washer head</td></tr> <tr><td><input type="checkbox"/></td><td>Anchor Rods</td><td>7/8" A307</td></tr> <tr><td><input type="checkbox"/></td><td></td><td>1" Rod</td></tr> <tr><td><input checked="" type="checkbox"/></td><td>Loading Beam:</td><td>A325 3/4" bolts</td></tr> <tr><td><input checked="" type="checkbox"/></td><td>Base</td><td>A325 3/4" bolts</td></tr> </table>			<input checked="" type="checkbox"/>	Straps	No. 10 gauge 0.75" self-drilling wafer head (mod. Truss) Phillips drive	<input checked="" type="checkbox"/>	Framing:	No. 8 gauge 0.5" self-drilling wafer head (mod. Truss) Phillips drive	<input type="checkbox"/>	Hold downs:	No. 14 gauge 1" self-drilling Hex washer head	<input checked="" type="checkbox"/>	Back-to-Back		<input checked="" type="checkbox"/>	Chord Studs:	No. 10 gauge 1" self-drilling Hex washer head	<input type="checkbox"/>	Anchor Rods	7/8" A307	<input type="checkbox"/>		1" Rod	<input checked="" type="checkbox"/>	Loading Beam:	A325 3/4" bolts	<input checked="" type="checkbox"/>	Base	A325 3/4" bolts								
<input checked="" type="checkbox"/>	Straps	No. 10 gauge 0.75" self-drilling wafer head (mod. Truss) Phillips drive																																				
<input checked="" type="checkbox"/>	Framing:	No. 8 gauge 0.5" self-drilling wafer head (mod. Truss) Phillips drive																																				
<input type="checkbox"/>	Hold downs:	No. 14 gauge 1" self-drilling Hex washer head																																				
<input checked="" type="checkbox"/>	Back-to-Back																																					
<input checked="" type="checkbox"/>	Chord Studs:	No. 10 gauge 1" self-drilling Hex washer head																																				
<input type="checkbox"/>	Anchor Rods	7/8" A307																																				
<input type="checkbox"/>		1" Rod																																				
<input checked="" type="checkbox"/>	Loading Beam:	A325 3/4" bolts																																				
<input checked="" type="checkbox"/>	Base	A325 3/4" bolts																																				
	12 bolts <input checked="" type="checkbox"/>	2 Anchor Rods <input checked="" type="checkbox"/>																																				
	8 bolts <input checked="" type="checkbox"/>	2 Anchor Rods <input checked="" type="checkbox"/>																																				
TRACK:	<table border="1" style="width:100%; border-collapse: collapse;"> <tr><td><input type="checkbox"/></td><td>Regular</td><td><input checked="" type="checkbox"/></td><td>6" web</td><td><input type="checkbox"/></td><td>0.043" (1.09mm) 33ksi (230 Mpa)</td></tr> <tr><td><input checked="" type="checkbox"/></td><td>Extended</td><td><input type="checkbox"/></td><td>3 5/8" web</td><td><input checked="" type="checkbox"/></td><td>0.054" (1.37mm) 50ksi (345 Mpa)</td></tr> <tr><td><input type="checkbox"/></td><td>Reinforced</td><td><input type="checkbox"/></td><td>1-1/4" flange</td><td><input type="checkbox"/></td><td>0.068" (1.73mm) 50ksi (345 Mpa)</td></tr> </table>			<input type="checkbox"/>	Regular	<input checked="" type="checkbox"/>	6" web	<input type="checkbox"/>	0.043" (1.09mm) 33ksi (230 Mpa)	<input checked="" type="checkbox"/>	Extended	<input type="checkbox"/>	3 5/8" web	<input checked="" type="checkbox"/>	0.054" (1.37mm) 50ksi (345 Mpa)	<input type="checkbox"/>	Reinforced	<input type="checkbox"/>	1-1/4" flange	<input type="checkbox"/>	0.068" (1.73mm) 50ksi (345 Mpa)																	
<input type="checkbox"/>	Regular	<input checked="" type="checkbox"/>	6" web	<input type="checkbox"/>	0.043" (1.09mm) 33ksi (230 Mpa)																																	
<input checked="" type="checkbox"/>	Extended	<input type="checkbox"/>	3 5/8" web	<input checked="" type="checkbox"/>	0.054" (1.37mm) 50ksi (345 Mpa)																																	
<input type="checkbox"/>	Reinforced	<input type="checkbox"/>	1-1/4" flange	<input type="checkbox"/>	0.068" (1.73mm) 50ksi (345 Mpa)																																	
HOLD DOWNS:	<table border="1" style="width:100%; border-collapse: collapse;"> <tr><td><input type="checkbox"/></td><td>S/HD10S Simpson</td><td></td><td></td><td></td></tr> <tr><td><input type="checkbox"/></td><td>Fabricated U-shape</td><td></td><td></td><td></td></tr> <tr><td><input type="checkbox"/></td><td>6" x 6" 0.054" (1.37mm) 50 ksi (340 MPa) Gusset Plate w/ S/HD15S Simpson</td><td></td><td></td><td></td></tr> <tr><td><input checked="" type="checkbox"/></td><td>7" x 9" 0.054" (1.37mm) 50 ksi (340 MPa) Gusset Plate w/ S/HD15S Simpson</td><td></td><td></td><td></td></tr> <tr><td><input type="checkbox"/></td><td>8" x 8" 0.068" (1.73mm) 50 ksi (340 MPa) Gusset Plate w/ S/HD15S Simpson</td><td></td><td></td><td></td></tr> <tr><td><input type="checkbox"/></td><td>8.5" x 10" 0.068" (1.73mm) 50 ksi (340 MPa) Gusset Plate w/ S/HD15S Simpson</td><td></td><td></td><td></td></tr> <tr><td><input type="checkbox"/></td><td>10" x 10" 0.054" (1.37mm) 50 ksi (340 MPa) Gusset Plate w/ S/HD15S Simpson</td><td></td><td></td><td></td></tr> </table>			<input type="checkbox"/>	S/HD10S Simpson				<input type="checkbox"/>	Fabricated U-shape				<input type="checkbox"/>	6" x 6" 0.054" (1.37mm) 50 ksi (340 MPa) Gusset Plate w/ S/HD15S Simpson				<input checked="" type="checkbox"/>	7" x 9" 0.054" (1.37mm) 50 ksi (340 MPa) Gusset Plate w/ S/HD15S Simpson				<input type="checkbox"/>	8" x 8" 0.068" (1.73mm) 50 ksi (340 MPa) Gusset Plate w/ S/HD15S Simpson				<input type="checkbox"/>	8.5" x 10" 0.068" (1.73mm) 50 ksi (340 MPa) Gusset Plate w/ S/HD15S Simpson				<input type="checkbox"/>	10" x 10" 0.054" (1.37mm) 50 ksi (340 MPa) Gusset Plate w/ S/HD15S Simpson			
<input type="checkbox"/>	S/HD10S Simpson																																					
<input type="checkbox"/>	Fabricated U-shape																																					
<input type="checkbox"/>	6" x 6" 0.054" (1.37mm) 50 ksi (340 MPa) Gusset Plate w/ S/HD15S Simpson																																					
<input checked="" type="checkbox"/>	7" x 9" 0.054" (1.37mm) 50 ksi (340 MPa) Gusset Plate w/ S/HD15S Simpson																																					
<input type="checkbox"/>	8" x 8" 0.068" (1.73mm) 50 ksi (340 MPa) Gusset Plate w/ S/HD15S Simpson																																					
<input type="checkbox"/>	8.5" x 10" 0.068" (1.73mm) 50 ksi (340 MPa) Gusset Plate w/ S/HD15S Simpson																																					
<input type="checkbox"/>	10" x 10" 0.054" (1.37mm) 50 ksi (340 MPa) Gusset Plate w/ S/HD15S Simpson																																					
TEST PROTOCOL AND DESCRIPTION:	<table border="1" style="width:100%; border-collapse: collapse;"> <tr><td><input type="checkbox"/></td><td>Monotonic (Rate of Loading 2.5 mm/min)</td></tr> <tr><td><input checked="" type="checkbox"/></td><td>Cyclic (CUREE cyclic protocol)</td></tr> </table>			<input type="checkbox"/>	Monotonic (Rate of Loading 2.5 mm/min)	<input checked="" type="checkbox"/>	Cyclic (CUREE cyclic protocol)																															
<input type="checkbox"/>	Monotonic (Rate of Loading 2.5 mm/min)																																					
<input checked="" type="checkbox"/>	Cyclic (CUREE cyclic protocol)																																					
LVDT MEASUREMENTS:	<table border="1" style="width:100%; border-collapse: collapse;"> <tr><td><input checked="" type="checkbox"/></td><td>Actuator LVDT</td><td><input checked="" type="checkbox"/></td><td>North Uplift</td></tr> <tr><td><input checked="" type="checkbox"/></td><td>North Slip</td><td><input checked="" type="checkbox"/></td><td>South Uplift</td></tr> <tr><td><input checked="" type="checkbox"/></td><td>South Slip</td><td><input checked="" type="checkbox"/></td><td>Top of Wall</td></tr> </table>			<input checked="" type="checkbox"/>	Actuator LVDT	<input checked="" type="checkbox"/>	North Uplift	<input checked="" type="checkbox"/>	North Slip	<input checked="" type="checkbox"/>	South Uplift	<input checked="" type="checkbox"/>	South Slip	<input checked="" type="checkbox"/>	Top of Wall																							
<input checked="" type="checkbox"/>	Actuator LVDT	<input checked="" type="checkbox"/>	North Uplift																																			
<input checked="" type="checkbox"/>	North Slip	<input checked="" type="checkbox"/>	South Uplift																																			
<input checked="" type="checkbox"/>	South Slip	<input checked="" type="checkbox"/>	Top of Wall																																			
	TOTAL: <input type="text" value="6"/>																																					
STRAP WIDTH BEFORE TEST:	<table border="1" style="width:100%; border-collapse: collapse;"> <tr><td></td><td>Front Right</td><td>Front Left, mm</td><td>Back Right, mm</td><td>Back Left, mm</td></tr> <tr><td></td><td>69.62</td><td>69.84</td><td>69.92</td><td>69.61</td></tr> <tr><td></td><td>69.78</td><td>69.90</td><td>69.95</td><td>69.82</td></tr> <tr><td></td><td>70.05</td><td>69.88</td><td>69.98</td><td>69.94</td></tr> <tr><td></td><td>AVG 69.82</td><td>AVG 69.87 mm</td><td>AVG 69.95 mm</td><td>AVG 69.79 mm</td></tr> </table>				Front Right	Front Left, mm	Back Right, mm	Back Left, mm		69.62	69.84	69.92	69.61		69.78	69.90	69.95	69.82		70.05	69.88	69.98	69.94		AVG 69.82	AVG 69.87 mm	AVG 69.95 mm	AVG 69.79 mm										
	Front Right	Front Left, mm	Back Right, mm	Back Left, mm																																		
	69.62	69.84	69.92	69.61																																		
	69.78	69.90	69.95	69.82																																		
	70.05	69.88	69.98	69.94																																		
	AVG 69.82	AVG 69.87 mm	AVG 69.95 mm	AVG 69.79 mm																																		
DATA ACQ. RECORD RATE:	100 scan/sec																																					
MONITOR RATE:	100 scan/sec																																					
COMMENTS:	<ul style="list-style-type: none"> -Shear anchors torqued for 10 s with impact wrench -Hold down anchors 1/2 turn from finger tight (load cells used on both hold-downs) -Ambient temperature 30 C -Double chord studs used screwed back to back -Square plate washers (2.5"x2.5") used in all top track connections -Regular washers used in all bottom track connections 																																					

Figure C. 5 Data sheet for test 28 A-C

Cold Formed Steel Strap Braced Walls McGill University, Montreal																																		
TEST:	30 A-C																																	
RESEARCHER:	Kostadin Velchev	ASSISTANTS:	Gilles Comeau, Nisreen Balh																															
DATE:	1-Aug-07		TIME:	9:13																														
DIMENSIONS OF WALL:	8 FT X	8 FT X	6 IN.	INITIAL STRAP SURVEY:	Front Back	Right tight tight	Left tight tight																											
STRAP FASTENER CONFIGURATION:				MFR:	McGill																													
STRAP SIZE:	<table border="0" style="width:100%;"> <tr><td><input type="checkbox"/></td><td>2.5" 0.043" (1.09mm) 33 ksi (230 MPa)</td></tr> <tr><td><input type="checkbox"/></td><td>2.75" 0.054" (1.37mm) 50 ksi (340 MPa)</td></tr> <tr><td><input type="checkbox"/></td><td>4" 0.068" (1.73mm) 50 ksi (340 MPa)</td></tr> <tr><td><input type="checkbox"/></td><td>5" 0.043" (1.09) 33 ksi (230 MPa)</td></tr> <tr><td><input type="checkbox"/></td><td>Reduced section strap -- fuse = 2.5" wide x 30" long -- ends = 3.75" wide 0.043" (1.09mm) 33 ksi (230 MPa)</td></tr> <tr><td><input checked="" type="checkbox"/></td><td>Reduced section strap -- fuse = 2.75" wide x 30" long -- ends = 4.25" wide 0.054" (1.37mm) 50 ksi (340 MPa)</td></tr> <tr><td><input type="checkbox"/></td><td>Reduced section strap -- fuse = 4" wide x 30" long -- ends = 6" wide 0.068" (1.73mm) 50 ksi (340 MPa)</td></tr> <tr><td><input type="checkbox"/></td><td>Reduced section strap -- fuse = 2.5" wide x 60" long -- ends = 3.75" wide 0.043" (1.09mm) 33 ksi (230 MPa)</td></tr> <tr><td><input type="checkbox"/></td><td>Reduced section strap -- fuse = 4" wide x 60" long -- ends = 6" wide 0.068" (1.73mm) 50 ksi (340 MPa)</td></tr> </table>							<input type="checkbox"/>	2.5" 0.043" (1.09mm) 33 ksi (230 MPa)	<input type="checkbox"/>	2.75" 0.054" (1.37mm) 50 ksi (340 MPa)	<input type="checkbox"/>	4" 0.068" (1.73mm) 50 ksi (340 MPa)	<input type="checkbox"/>	5" 0.043" (1.09) 33 ksi (230 MPa)	<input type="checkbox"/>	Reduced section strap -- fuse = 2.5" wide x 30" long -- ends = 3.75" wide 0.043" (1.09mm) 33 ksi (230 MPa)	<input checked="" type="checkbox"/>	Reduced section strap -- fuse = 2.75" wide x 30" long -- ends = 4.25" wide 0.054" (1.37mm) 50 ksi (340 MPa)	<input type="checkbox"/>	Reduced section strap -- fuse = 4" wide x 30" long -- ends = 6" wide 0.068" (1.73mm) 50 ksi (340 MPa)	<input type="checkbox"/>	Reduced section strap -- fuse = 2.5" wide x 60" long -- ends = 3.75" wide 0.043" (1.09mm) 33 ksi (230 MPa)	<input type="checkbox"/>	Reduced section strap -- fuse = 4" wide x 60" long -- ends = 6" wide 0.068" (1.73mm) 50 ksi (340 MPa)									
<input type="checkbox"/>	2.5" 0.043" (1.09mm) 33 ksi (230 MPa)																																	
<input type="checkbox"/>	2.75" 0.054" (1.37mm) 50 ksi (340 MPa)																																	
<input type="checkbox"/>	4" 0.068" (1.73mm) 50 ksi (340 MPa)																																	
<input type="checkbox"/>	5" 0.043" (1.09) 33 ksi (230 MPa)																																	
<input type="checkbox"/>	Reduced section strap -- fuse = 2.5" wide x 30" long -- ends = 3.75" wide 0.043" (1.09mm) 33 ksi (230 MPa)																																	
<input checked="" type="checkbox"/>	Reduced section strap -- fuse = 2.75" wide x 30" long -- ends = 4.25" wide 0.054" (1.37mm) 50 ksi (340 MPa)																																	
<input type="checkbox"/>	Reduced section strap -- fuse = 4" wide x 30" long -- ends = 6" wide 0.068" (1.73mm) 50 ksi (340 MPa)																																	
<input type="checkbox"/>	Reduced section strap -- fuse = 2.5" wide x 60" long -- ends = 3.75" wide 0.043" (1.09mm) 33 ksi (230 MPa)																																	
<input type="checkbox"/>	Reduced section strap -- fuse = 4" wide x 60" long -- ends = 6" wide 0.068" (1.73mm) 50 ksi (340 MPa)																																	
INTERIOR STUDS:	<table border="0" style="width:100%;"> <tr><td><input type="checkbox"/></td><td>3-5/8"Wx1-5/8"Fx1/2"Lip 0.043" (1.09mm) 33ksi (230 Mpa)</td></tr> <tr><td><input checked="" type="checkbox"/></td><td>6"Wx1-5/8"Fx1/2"Lip 0.043" (1.09mm) 33ksi (230 Mpa)</td></tr> </table>		<input type="checkbox"/>	3-5/8"Wx1-5/8"Fx1/2"Lip 0.043" (1.09mm) 33ksi (230 Mpa)	<input checked="" type="checkbox"/>	6"Wx1-5/8"Fx1/2"Lip 0.043" (1.09mm) 33ksi (230 Mpa)	STUD SPACING:	<table border="0" style="width:100%;"> <tr><td><input checked="" type="checkbox"/></td><td>16" O.C.</td></tr> <tr><td><input type="checkbox"/></td><td>Other : _____</td></tr> </table>			<input checked="" type="checkbox"/>	16" O.C.	<input type="checkbox"/>	Other : _____																				
<input type="checkbox"/>	3-5/8"Wx1-5/8"Fx1/2"Lip 0.043" (1.09mm) 33ksi (230 Mpa)																																	
<input checked="" type="checkbox"/>	6"Wx1-5/8"Fx1/2"Lip 0.043" (1.09mm) 33ksi (230 Mpa)																																	
<input checked="" type="checkbox"/>	16" O.C.																																	
<input type="checkbox"/>	Other : _____																																	
BACK-TO-BACK CHORD STUDS:	<table border="0" style="width:100%;"> <tr><td><input type="checkbox"/></td><td>3-5/8"Wx1-5/8"Fx1/2"Lip 0.043" (1.09mm) 33ksi (230 Mpa)</td></tr> <tr><td><input type="checkbox"/></td><td>6"Wx1-5/8"Fx1/2"Lip 0.054" (1.37mm) 50ksi (345 Mpa)</td></tr> <tr><td><input checked="" type="checkbox"/></td><td>6"Wx1-5/8"Fx1/2"Lip 0.068" (1.73mm) 50ksi (345 Mpa)</td></tr> </table>							<input type="checkbox"/>	3-5/8"Wx1-5/8"Fx1/2"Lip 0.043" (1.09mm) 33ksi (230 Mpa)	<input type="checkbox"/>	6"Wx1-5/8"Fx1/2"Lip 0.054" (1.37mm) 50ksi (345 Mpa)	<input checked="" type="checkbox"/>	6"Wx1-5/8"Fx1/2"Lip 0.068" (1.73mm) 50ksi (345 Mpa)																					
<input type="checkbox"/>	3-5/8"Wx1-5/8"Fx1/2"Lip 0.043" (1.09mm) 33ksi (230 Mpa)																																	
<input type="checkbox"/>	6"Wx1-5/8"Fx1/2"Lip 0.054" (1.37mm) 50ksi (345 Mpa)																																	
<input checked="" type="checkbox"/>	6"Wx1-5/8"Fx1/2"Lip 0.068" (1.73mm) 50ksi (345 Mpa)																																	
CONNECTIONS:	<table border="0" style="width:100%;"> <tr><td>Straps:</td><td><input checked="" type="checkbox"/></td><td>No.10 gauge 0.75" self-drilling wafer head (mod. Truss) Phillips drive</td></tr> <tr><td>Framing:</td><td><input checked="" type="checkbox"/></td><td>No.8 gauge 0.5" self-drilling wafer head (mod. Truss) Phillips drive</td></tr> <tr><td>Hold downs:</td><td><input checked="" type="checkbox"/></td><td>No.14 gauge 1" self-drilling Hex washer head</td></tr> <tr><td>Back-to-Back:</td><td><input checked="" type="checkbox"/></td><td>No.14 gauge 1" self-drilling Hex washer head</td></tr> <tr><td>Chord Studs:</td><td><input checked="" type="checkbox"/></td><td>No.10 gauge 0.75" self-drilling Hex washer head</td></tr> <tr><td>Anchor Rods:</td><td><input type="checkbox"/></td><td>7/8" A307</td></tr> <tr><td></td><td><input checked="" type="checkbox"/></td><td>1" Rod</td></tr> <tr><td>Loading Beam:</td><td><input checked="" type="checkbox"/></td><td>A325 3/4" bolts</td></tr> <tr><td>Base:</td><td><input checked="" type="checkbox"/></td><td>A325 3/4" bolts</td></tr> </table>							Straps:	<input checked="" type="checkbox"/>	No.10 gauge 0.75" self-drilling wafer head (mod. Truss) Phillips drive	Framing:	<input checked="" type="checkbox"/>	No.8 gauge 0.5" self-drilling wafer head (mod. Truss) Phillips drive	Hold downs:	<input checked="" type="checkbox"/>	No.14 gauge 1" self-drilling Hex washer head	Back-to-Back:	<input checked="" type="checkbox"/>	No.14 gauge 1" self-drilling Hex washer head	Chord Studs:	<input checked="" type="checkbox"/>	No.10 gauge 0.75" self-drilling Hex washer head	Anchor Rods:	<input type="checkbox"/>	7/8" A307		<input checked="" type="checkbox"/>	1" Rod	Loading Beam:	<input checked="" type="checkbox"/>	A325 3/4" bolts	Base:	<input checked="" type="checkbox"/>	A325 3/4" bolts
Straps:	<input checked="" type="checkbox"/>	No.10 gauge 0.75" self-drilling wafer head (mod. Truss) Phillips drive																																
Framing:	<input checked="" type="checkbox"/>	No.8 gauge 0.5" self-drilling wafer head (mod. Truss) Phillips drive																																
Hold downs:	<input checked="" type="checkbox"/>	No.14 gauge 1" self-drilling Hex washer head																																
Back-to-Back:	<input checked="" type="checkbox"/>	No.14 gauge 1" self-drilling Hex washer head																																
Chord Studs:	<input checked="" type="checkbox"/>	No.10 gauge 0.75" self-drilling Hex washer head																																
Anchor Rods:	<input type="checkbox"/>	7/8" A307																																
	<input checked="" type="checkbox"/>	1" Rod																																
Loading Beam:	<input checked="" type="checkbox"/>	A325 3/4" bolts																																
Base:	<input checked="" type="checkbox"/>	A325 3/4" bolts																																
TRACK:	<table border="0" style="width:100%;"> <tr><td><input checked="" type="checkbox"/></td><td>Regular</td><td><input checked="" type="checkbox"/></td><td>6" web</td></tr> <tr><td><input type="checkbox"/></td><td>Extended</td><td><input type="checkbox"/></td><td>3 5/8" web</td></tr> <tr><td><input type="checkbox"/></td><td>Reinforced</td><td><input type="checkbox"/></td><td>1-1/4" flange</td></tr> </table>		<input checked="" type="checkbox"/>	Regular	<input checked="" type="checkbox"/>	6" web	<input type="checkbox"/>	Extended	<input type="checkbox"/>	3 5/8" web	<input type="checkbox"/>	Reinforced	<input type="checkbox"/>	1-1/4" flange	<table border="0" style="width:100%;"> <tr><td><input type="checkbox"/></td><td>0.043" (1.09mm) 33ksi (230 Mpa)</td></tr> <tr><td><input type="checkbox"/></td><td>0.054" (1.37mm) 50ksi (345 Mpa)</td></tr> <tr><td><input checked="" type="checkbox"/></td><td>0.068" (1.73mm) 50ksi (345 Mpa)</td></tr> </table>					<input type="checkbox"/>	0.043" (1.09mm) 33ksi (230 Mpa)	<input type="checkbox"/>	0.054" (1.37mm) 50ksi (345 Mpa)	<input checked="" type="checkbox"/>	0.068" (1.73mm) 50ksi (345 Mpa)									
<input checked="" type="checkbox"/>	Regular	<input checked="" type="checkbox"/>	6" web																															
<input type="checkbox"/>	Extended	<input type="checkbox"/>	3 5/8" web																															
<input type="checkbox"/>	Reinforced	<input type="checkbox"/>	1-1/4" flange																															
<input type="checkbox"/>	0.043" (1.09mm) 33ksi (230 Mpa)																																	
<input type="checkbox"/>	0.054" (1.37mm) 50ksi (345 Mpa)																																	
<input checked="" type="checkbox"/>	0.068" (1.73mm) 50ksi (345 Mpa)																																	
HOLD DOWNS:	<table border="0" style="width:100%;"> <tr><td><input type="checkbox"/></td><td>S/HD10S Simpson</td></tr> <tr><td><input type="checkbox"/></td><td>Fabricated U-shape</td></tr> <tr><td><input type="checkbox"/></td><td>6" x 6" 0.054" (1.37mm) 50 ksi (340 MPa) Gusset Plate w/ S/HD15SS Simpson</td></tr> <tr><td><input type="checkbox"/></td><td>7" x 9" 0.054" (1.37mm) 50 ksi (340 MPa) Gusset Plate w/ S/HD15SS Simpson</td></tr> <tr><td><input type="checkbox"/></td><td>8" x 8" 0.068" (1.73mm) 50 ksi (340 MPa) Gusset Plate w/ S/HD15SS Simpson</td></tr> <tr><td><input checked="" type="checkbox"/></td><td>8.5" x10" 0.068" (1.73mm) 50 ksi (340 MPa) Gusset Plate w/ S/HD15SS Simpson</td></tr> <tr><td><input type="checkbox"/></td><td>10" x10" 0.054" (1.37mm) 50 ksi (340 MPa) Gusset Plate w/ S/HD15SS Simpson</td></tr> </table>							<input type="checkbox"/>	S/HD10S Simpson	<input type="checkbox"/>	Fabricated U-shape	<input type="checkbox"/>	6" x 6" 0.054" (1.37mm) 50 ksi (340 MPa) Gusset Plate w/ S/HD15SS Simpson	<input type="checkbox"/>	7" x 9" 0.054" (1.37mm) 50 ksi (340 MPa) Gusset Plate w/ S/HD15SS Simpson	<input type="checkbox"/>	8" x 8" 0.068" (1.73mm) 50 ksi (340 MPa) Gusset Plate w/ S/HD15SS Simpson	<input checked="" type="checkbox"/>	8.5" x10" 0.068" (1.73mm) 50 ksi (340 MPa) Gusset Plate w/ S/HD15SS Simpson	<input type="checkbox"/>	10" x10" 0.054" (1.37mm) 50 ksi (340 MPa) Gusset Plate w/ S/HD15SS Simpson													
<input type="checkbox"/>	S/HD10S Simpson																																	
<input type="checkbox"/>	Fabricated U-shape																																	
<input type="checkbox"/>	6" x 6" 0.054" (1.37mm) 50 ksi (340 MPa) Gusset Plate w/ S/HD15SS Simpson																																	
<input type="checkbox"/>	7" x 9" 0.054" (1.37mm) 50 ksi (340 MPa) Gusset Plate w/ S/HD15SS Simpson																																	
<input type="checkbox"/>	8" x 8" 0.068" (1.73mm) 50 ksi (340 MPa) Gusset Plate w/ S/HD15SS Simpson																																	
<input checked="" type="checkbox"/>	8.5" x10" 0.068" (1.73mm) 50 ksi (340 MPa) Gusset Plate w/ S/HD15SS Simpson																																	
<input type="checkbox"/>	10" x10" 0.054" (1.37mm) 50 ksi (340 MPa) Gusset Plate w/ S/HD15SS Simpson																																	
TEST PROTOCOL AND DESCRIPTION:	<table border="0" style="width:100%;"> <tr><td><input type="checkbox"/></td><td>Monotonic (Rate of Loading 2.5 mm/min)</td></tr> <tr><td><input checked="" type="checkbox"/></td><td>Cyclic (CUREE cyclic protocol)</td></tr> </table>							<input type="checkbox"/>	Monotonic (Rate of Loading 2.5 mm/min)	<input checked="" type="checkbox"/>	Cyclic (CUREE cyclic protocol)																							
<input type="checkbox"/>	Monotonic (Rate of Loading 2.5 mm/min)																																	
<input checked="" type="checkbox"/>	Cyclic (CUREE cyclic protocol)																																	
LVDT MEASUREMENTS:	<table border="0" style="width:100%;"> <tr><td><input checked="" type="checkbox"/></td><td>Actuator LVDT</td><td><input checked="" type="checkbox"/></td><td>North Uplift</td></tr> <tr><td><input checked="" type="checkbox"/></td><td>North Slip</td><td><input checked="" type="checkbox"/></td><td>South Uplift</td></tr> <tr><td><input checked="" type="checkbox"/></td><td>South Slip</td><td><input checked="" type="checkbox"/></td><td>Top of Wall</td></tr> </table>							<input checked="" type="checkbox"/>	Actuator LVDT	<input checked="" type="checkbox"/>	North Uplift	<input checked="" type="checkbox"/>	North Slip	<input checked="" type="checkbox"/>	South Uplift	<input checked="" type="checkbox"/>	South Slip	<input checked="" type="checkbox"/>	Top of Wall															
<input checked="" type="checkbox"/>	Actuator LVDT	<input checked="" type="checkbox"/>	North Uplift																															
<input checked="" type="checkbox"/>	North Slip	<input checked="" type="checkbox"/>	South Uplift																															
<input checked="" type="checkbox"/>	South Slip	<input checked="" type="checkbox"/>	Top of Wall																															
TOTAL:							6																											
STRAP WIDTH BEFORE TEST:	<table border="0" style="width:100%;"> <tr> <td style="text-align: center;">Front Right</td> <td style="text-align: center;">Front Left, mm</td> <td style="text-align: center;">Back Right, mm</td> <td style="text-align: center;">Back Left, mm</td> </tr> <tr> <td style="text-align: center;">101.87</td> <td style="text-align: center;">101.92</td> <td style="text-align: center;">101.75</td> <td style="text-align: center;">101.86</td> </tr> <tr> <td style="text-align: center;">101.73</td> <td style="text-align: center;">101.69</td> <td style="text-align: center;">101.83</td> <td style="text-align: center;">101.74</td> </tr> <tr> <td style="text-align: center;">101.65</td> <td style="text-align: center;">101.34</td> <td style="text-align: center;">101.84</td> <td style="text-align: center;">101.71</td> </tr> <tr> <td style="text-align: center;">AVG</td> <td style="text-align: center;">101.75</td> <td style="text-align: center;">AVG</td> <td style="text-align: center;">101.77</td> </tr> </table>							Front Right	Front Left, mm	Back Right, mm	Back Left, mm	101.87	101.92	101.75	101.86	101.73	101.69	101.83	101.74	101.65	101.34	101.84	101.71	AVG	101.75	AVG	101.77							
Front Right	Front Left, mm	Back Right, mm	Back Left, mm																															
101.87	101.92	101.75	101.86																															
101.73	101.69	101.83	101.74																															
101.65	101.34	101.84	101.71																															
AVG	101.75	AVG	101.77																															
DATA ACQ. RECORD RATE:	100 scan/sec			MONITOR RATE:	100 scan/sec																													
COMMENTS:	<ul style="list-style-type: none"> -Shear anchors torqued for 10 s with impact wrench -Hold down anchors 1/2 turn from finger tight (load cells used on both hold-downs) -Ambient temperature 29 C -Double chord studs used screwed back to back -Square plate washers (2.5"x2.5") used in all top track connections -Regular washers used in all bottom track connections 																																	

Figure C. 7 Data sheet for test 30 A-C

Cold Formed Steel Strap Braced Walls
McGill University, Montreal

TEST: 31 A-M

RESEARCHER: Kostadin Velchev ASSISTANTS: Gilles Comeau, Nisreen Balh

DATE: June 13, 2007 TIME: 14:37

DIMENSIONS OF WALL: 8 FT X 8 FT X 3-5/8 IN. INITIAL STRAP SURVEY: Front Back Right tight Left tight loose

STRAP FASTENER CONFIGURATION: MFR: McGill

STRAP SIZE:

<input type="checkbox"/>	2.5" 0.043" (1.09mm) 33 ksi (230 MPa)
<input type="checkbox"/>	2.75" 0.054" (1.37mm) 50 ksi (340 MPa)
<input type="checkbox"/>	4" 0.068" (1.73mm) 50 ksi (340 MPa)
<input type="checkbox"/>	5" 0.043" (1.09) 33 ksi (230 MPa)
<input type="checkbox"/>	Reduced section strap -- fuse = 2.5" wide x 30" long -- ends = 3.75" wide 0.043" (1.09mm) 33 ksi (230 MPa)
<input type="checkbox"/>	Reduced section strap -- fuse = 2.75" wide x 30" long -- ends = 4.25" wide 0.054" (1.37mm) 50 ksi (340 MPa)
<input type="checkbox"/>	Reduced section strap -- fuse = 4" wide x 30" long -- ends = 6" wide 0.068" (1.73mm) 50 ksi (340 MPa)
<input checked="" type="checkbox"/>	Reduced section strap -- fuse = 2.5" wide x 60" long -- ends = 3.75" wide 0.043" (1.09mm) 33 ksi (230 MPa)
<input type="checkbox"/>	Reduced section strap -- fuse = 4" wide x 60" long -- ends = 6" wide 0.068" (1.73mm) 50 ksi (340 MPa)

INTERIOR STUDS:

<input checked="" type="checkbox"/>	3-5/8"Wx1-5/8"Fx1/2"Lip 0.043" (1.09mm) 33ksi (230 Mpa)
<input type="checkbox"/>	6"Wx1-5/8"Fx1/2"Lip 0.043" (1.09mm) 33ksi (230 Mpa)

STUD SPACING: 16" O.C. Other: _____

BACK-TO-BACK CHORD STUDS:

<input checked="" type="checkbox"/>	3-5/8"Wx1-5/8"Fx1/2"Lip 0.043" (1.09mm) 33ksi (230 Mpa)
<input type="checkbox"/>	6"Wx1-5/8"Fx1/2"Lip 0.054" (1.37mm) 50ksi (345 Mpa)
<input type="checkbox"/>	6"Wx1-5/8"Fx1/2"Lip 0.068" (1.73mm) 50ksi (345 Mpa)

CONNECTIONS:

<input checked="" type="checkbox"/>	Straps	No. 10 gauge 0.75" self-drilling wafer head (mod. Truss) Phillips drive
<input checked="" type="checkbox"/>	Framing:	No. 8 gauge 0.5" self-drilling wafer head (mod. Truss) Phillips drive
<input checked="" type="checkbox"/>	Hold downs:	No. 14 gauge 3/4" self-drilling Hex washer head
<input checked="" type="checkbox"/>	Back-to-Back	
<input checked="" type="checkbox"/>	Chord Studs:	No. 10 gauge 0.75" self-drilling Hex washer head
<input checked="" type="checkbox"/>	Anchor Rods	7/8" A307
<input checked="" type="checkbox"/>	1" Rod	
<input checked="" type="checkbox"/>	Loading Beam:	A325 3/4" bolts
<input checked="" type="checkbox"/>	Base	A325 3/4" bolts

12 bolts 2 Anchor Rods
8 bolts 2 Anchor Rods

TRACK:

<input type="checkbox"/>	Regular	6" web	<input checked="" type="checkbox"/>	0.043" (1.09mm) 33ksi (230 Mpa)
<input checked="" type="checkbox"/>	Extended	3 5/8" web	<input type="checkbox"/>	0.054" (1.37mm) 50ksi (345 Mpa)
<input type="checkbox"/>	Reinforced	1-1/4" flange	<input type="checkbox"/>	0.068" (1.73mm) 50ksi (345 Mpa)

HOLD DOWNS:

<input checked="" type="checkbox"/>	S/HD10S Simpson	inside	outside	raised
<input type="checkbox"/>	Fabricated U-shape		<input checked="" type="checkbox"/>	
<input type="checkbox"/>	6" x 6" 0.054" (1.37mm) 50 ksi (340 MPa) Gusset Plate w/ S/HD15S Simpson			
<input type="checkbox"/>	7" x 9" 0.054" (1.37mm) 50 ksi (340 MPa) Gusset Plate w/ S/HD15S Simpson			
<input type="checkbox"/>	8" x 8" 0.068" (1.73mm) 50 ksi (340 MPa) Gusset Plate w/ S/HD15S Simpson			
<input type="checkbox"/>	8.5" x 10" 0.068" (1.73mm) 50 ksi (340 MPa) Gusset Plate w/ S/HD15S Simpson			
<input type="checkbox"/>	10" x 10" 0.054" (1.37mm) 50 ksi (340 MPa) Gusset Plate w/ S/HD15S Simpson			

TEST PROTOCOL AND DESCRIPTION:

<input checked="" type="checkbox"/>	Monotonic (Rate of Loading 2.5 mm/min)
<input type="checkbox"/>	Cyclic (CUREE cyclic protocol)

LVDT MEASUREMENTS:

<input checked="" type="checkbox"/>	Actuator LVDT	<input checked="" type="checkbox"/>	North Uplift
<input checked="" type="checkbox"/>	North Slip	<input checked="" type="checkbox"/>	South Uplift
<input checked="" type="checkbox"/>	South Slip	<input checked="" type="checkbox"/>	Top of Wall

TOTAL:

STRAP WIDTH BEFORE TEST:

Front Right	63.78	Front Left, mm	63.03	Back Right, mm	62.99	Back Left, mm	63.85
	63.43		63.15		63.15		63.53
	65.00		63.93		63.81		65.25
AVG	64.07	AVG	63.37 mm	AVG	63.32 mm	AVG	64.21 mm

DATA ACQ. RECORD RATE: 1 scan/sec MONITOR RATE: 10 scan/sec

COMMENTS:

- Shear anchors torqued for 10 s with impact wrench
- Hold down anchors 1/2 turn from finger tight (load cells used on both hold-downs)
- Ambient temperature 28 C
- Double chord studs used screwed back to back
- Square plate washers (2.5"x2.5") used in all top track connections
- Regular washers used in all bottom track connections

Figure C. 8 Data sheet for test 31 A-M

Cold Formed Steel Strap Braced Walls																																									
McGill University, Montreal																																									
TEST:	32 A-C																																								
RESEARCHER:	Kostadin Velchev	ASSISTANTS:	Gilles Comeau, Nisreen Balh																																						
DATE:	25-Jul-07		TIME:	11:22																																					
DIMENSIONS OF WALL:	8 FT X	8 FT X	3-5/8 IN.	INITIAL STRAP SURVEY:	Front Back	Right tight Left tight																																			
STRAP FASTENER CONFIGURATION:				MFR:	McGill																																				
STRAP SIZE:	<table border="0" style="width:100%;"> <tr><td><input type="checkbox"/></td><td>2.5" 0.043" (1.09mm) 33 ksi (230 MPa)</td></tr> <tr><td><input type="checkbox"/></td><td>2.75" 0.054" (1.37mm) 50 ksi (340 MPa)</td></tr> <tr><td><input type="checkbox"/></td><td>4" 0.068" (1.73mm) 50 ksi (340 MPa)</td></tr> <tr><td><input type="checkbox"/></td><td>5" 0.043" (1.09) 33 ksi (230 MPa)</td></tr> <tr><td><input type="checkbox"/></td><td>Reduced section strap -- fuse = 2.5" wide x 30" long -- ends = 3.75" wide 0.043" (1.09mm) 33 ksi (230 MPa)</td></tr> <tr><td><input type="checkbox"/></td><td>Reduced section strap -- fuse = 2.75" wide x 30" long -- ends = 4.25" wide 0.054" (1.37mm) 50 ksi (340 MPa)</td></tr> <tr><td><input type="checkbox"/></td><td>Reduced section strap -- fuse = 4" wide x 30" long -- ends = 6" wide 0.068" (1.73mm) 50 ksi (340 MPa)</td></tr> <tr><td><input checked="" type="checkbox"/></td><td>Reduced section strap -- fuse = 2.5" wide x 60" long -- ends = 3.75" wide 0.043" (1.09mm) 33 ksi (230 MPa)</td></tr> <tr><td><input type="checkbox"/></td><td>Reduced section strap -- fuse = 4" wide x 60" long -- ends = 6" wide 0.068" (1.73mm) 50 ksi (340 MPa)</td></tr> </table>						<input type="checkbox"/>	2.5" 0.043" (1.09mm) 33 ksi (230 MPa)	<input type="checkbox"/>	2.75" 0.054" (1.37mm) 50 ksi (340 MPa)	<input type="checkbox"/>	4" 0.068" (1.73mm) 50 ksi (340 MPa)	<input type="checkbox"/>	5" 0.043" (1.09) 33 ksi (230 MPa)	<input type="checkbox"/>	Reduced section strap -- fuse = 2.5" wide x 30" long -- ends = 3.75" wide 0.043" (1.09mm) 33 ksi (230 MPa)	<input type="checkbox"/>	Reduced section strap -- fuse = 2.75" wide x 30" long -- ends = 4.25" wide 0.054" (1.37mm) 50 ksi (340 MPa)	<input type="checkbox"/>	Reduced section strap -- fuse = 4" wide x 30" long -- ends = 6" wide 0.068" (1.73mm) 50 ksi (340 MPa)	<input checked="" type="checkbox"/>	Reduced section strap -- fuse = 2.5" wide x 60" long -- ends = 3.75" wide 0.043" (1.09mm) 33 ksi (230 MPa)	<input type="checkbox"/>	Reduced section strap -- fuse = 4" wide x 60" long -- ends = 6" wide 0.068" (1.73mm) 50 ksi (340 MPa)																	
<input type="checkbox"/>	2.5" 0.043" (1.09mm) 33 ksi (230 MPa)																																								
<input type="checkbox"/>	2.75" 0.054" (1.37mm) 50 ksi (340 MPa)																																								
<input type="checkbox"/>	4" 0.068" (1.73mm) 50 ksi (340 MPa)																																								
<input type="checkbox"/>	5" 0.043" (1.09) 33 ksi (230 MPa)																																								
<input type="checkbox"/>	Reduced section strap -- fuse = 2.5" wide x 30" long -- ends = 3.75" wide 0.043" (1.09mm) 33 ksi (230 MPa)																																								
<input type="checkbox"/>	Reduced section strap -- fuse = 2.75" wide x 30" long -- ends = 4.25" wide 0.054" (1.37mm) 50 ksi (340 MPa)																																								
<input type="checkbox"/>	Reduced section strap -- fuse = 4" wide x 30" long -- ends = 6" wide 0.068" (1.73mm) 50 ksi (340 MPa)																																								
<input checked="" type="checkbox"/>	Reduced section strap -- fuse = 2.5" wide x 60" long -- ends = 3.75" wide 0.043" (1.09mm) 33 ksi (230 MPa)																																								
<input type="checkbox"/>	Reduced section strap -- fuse = 4" wide x 60" long -- ends = 6" wide 0.068" (1.73mm) 50 ksi (340 MPa)																																								
INTERIOR STUDS:	<input checked="" type="checkbox"/> 3-5/8"Wx1-5/8"Fx1/2"Lip 0.043" (1.09mm) 33ksi (230 Mpa) <input type="checkbox"/> 6"Wx1-5/8"Fx1/2"Lip 0.043" (1.09mm) 33ksi (230 Mpa)		STUD SPACING:	<input checked="" type="checkbox"/> 16" O.C. <input type="checkbox"/> Other : _____																																					
BACK-TO-BACK CHORD STUDS:	<input checked="" type="checkbox"/> 3-5/8"Wx1-5/8"Fx1/2"Lip 0.043" (1.09mm) 33ksi (230 Mpa) <input type="checkbox"/> 6"Wx1-5/8"Fx1/2"Lip 0.054" (1.37mm) 50ksi (345 Mpa) <input type="checkbox"/> 6"Wx1-5/8"Fx1/2"Lip 0.068" (1.73mm) 50ksi (345 Mpa)																																								
CONNECTIONS:	<table border="0" style="width:100%;"> <tr><td>Straps:</td><td><input checked="" type="checkbox"/></td><td>No.10 gauge 0.75" self-drilling wafer head (mod. Truss) Phillips drive</td></tr> <tr><td>Framing:</td><td><input checked="" type="checkbox"/></td><td>No.8 gauge 0.5" self-drilling wafer head (mod. Truss) Phillips drive</td></tr> <tr><td>Hold downs:</td><td><input checked="" type="checkbox"/></td><td>No.14 gauge 3/4" self-drilling Hex washer head</td></tr> <tr><td>Back-to-Back:</td><td><input checked="" type="checkbox"/></td><td>No.14 gauge 3/4" self-drilling Hex washer head</td></tr> <tr><td>Chord Studs:</td><td><input checked="" type="checkbox"/></td><td>No.10 gauge 0.75" self-drilling Hex washer head</td></tr> <tr><td>Anchor Rods:</td><td><input checked="" type="checkbox"/></td><td>7/8" A307</td></tr> <tr><td></td><td><input checked="" type="checkbox"/></td><td>1" Rod</td></tr> <tr><td>Loading Beam:</td><td><input checked="" type="checkbox"/></td><td>A325 3/4" bolts</td></tr> <tr><td>Base:</td><td><input checked="" type="checkbox"/></td><td>A325 3/4" bolts</td></tr> </table>						Straps:	<input checked="" type="checkbox"/>	No.10 gauge 0.75" self-drilling wafer head (mod. Truss) Phillips drive	Framing:	<input checked="" type="checkbox"/>	No.8 gauge 0.5" self-drilling wafer head (mod. Truss) Phillips drive	Hold downs:	<input checked="" type="checkbox"/>	No.14 gauge 3/4" self-drilling Hex washer head	Back-to-Back:	<input checked="" type="checkbox"/>	No.14 gauge 3/4" self-drilling Hex washer head	Chord Studs:	<input checked="" type="checkbox"/>	No.10 gauge 0.75" self-drilling Hex washer head	Anchor Rods:	<input checked="" type="checkbox"/>	7/8" A307		<input checked="" type="checkbox"/>	1" Rod	Loading Beam:	<input checked="" type="checkbox"/>	A325 3/4" bolts	Base:	<input checked="" type="checkbox"/>	A325 3/4" bolts								
Straps:	<input checked="" type="checkbox"/>	No.10 gauge 0.75" self-drilling wafer head (mod. Truss) Phillips drive																																							
Framing:	<input checked="" type="checkbox"/>	No.8 gauge 0.5" self-drilling wafer head (mod. Truss) Phillips drive																																							
Hold downs:	<input checked="" type="checkbox"/>	No.14 gauge 3/4" self-drilling Hex washer head																																							
Back-to-Back:	<input checked="" type="checkbox"/>	No.14 gauge 3/4" self-drilling Hex washer head																																							
Chord Studs:	<input checked="" type="checkbox"/>	No.10 gauge 0.75" self-drilling Hex washer head																																							
Anchor Rods:	<input checked="" type="checkbox"/>	7/8" A307																																							
	<input checked="" type="checkbox"/>	1" Rod																																							
Loading Beam:	<input checked="" type="checkbox"/>	A325 3/4" bolts																																							
Base:	<input checked="" type="checkbox"/>	A325 3/4" bolts																																							
TRACK:	<input type="checkbox"/> Regular <input checked="" type="checkbox"/> Extended <input type="checkbox"/> Reinforced		<input checked="" type="checkbox"/> 6" web <input checked="" type="checkbox"/> 3 5/8" web <input type="checkbox"/> 1-1/4" flange	<table border="0" style="width:100%;"> <tr><td><input checked="" type="checkbox"/></td><td>0.043" (1.09mm) 33ksi (230 Mpa)</td></tr> <tr><td><input type="checkbox"/></td><td>0.054" (1.37mm) 50ksi (345 Mpa)</td></tr> <tr><td><input type="checkbox"/></td><td>0.068" (1.73mm) 50ksi (345 Mpa)</td></tr> </table>			<input checked="" type="checkbox"/>	0.043" (1.09mm) 33ksi (230 Mpa)	<input type="checkbox"/>	0.054" (1.37mm) 50ksi (345 Mpa)	<input type="checkbox"/>	0.068" (1.73mm) 50ksi (345 Mpa)																													
<input checked="" type="checkbox"/>	0.043" (1.09mm) 33ksi (230 Mpa)																																								
<input type="checkbox"/>	0.054" (1.37mm) 50ksi (345 Mpa)																																								
<input type="checkbox"/>	0.068" (1.73mm) 50ksi (345 Mpa)																																								
HOLD DOWNS:	<table border="0" style="width:100%;"> <tr><td><input checked="" type="checkbox"/></td><td>S/HD10S Simpson</td><td style="text-align: center;">inside</td><td style="text-align: center;">outside</td><td style="text-align: center;">raised</td></tr> <tr><td><input type="checkbox"/></td><td>Fabricated U-shape</td><td></td><td></td><td></td></tr> <tr><td><input type="checkbox"/></td><td>6" x 6" 0.054" (1.37mm) 50 ksi (340 MPa) Gusset Plate w/ S/HD15S Simpson</td><td></td><td style="text-align: center;"><input checked="" type="checkbox"/></td><td></td></tr> <tr><td><input type="checkbox"/></td><td>7" x 9" 0.054" (1.37mm) 50 ksi (340 MPa) Gusset Plate w/ S/HD15S Simpson</td><td></td><td></td><td></td></tr> <tr><td><input type="checkbox"/></td><td>8" x 8" 0.068" (1.73mm) 50 ksi (340 MPa) Gusset Plate w/ S/HD15S Simpson</td><td></td><td></td><td></td></tr> <tr><td><input type="checkbox"/></td><td>8.5" x 10" 0.068" (1.73mm) 50 ksi (340 MPa) Gusset Plate w/ S/HD15S Simpson</td><td></td><td></td><td></td></tr> <tr><td><input type="checkbox"/></td><td>10" x 10" 0.054" (1.37mm) 50 ksi (340 MPa) Gusset Plate w/ S/HD15S Simpson</td><td></td><td></td><td></td></tr> </table>						<input checked="" type="checkbox"/>	S/HD10S Simpson	inside	outside	raised	<input type="checkbox"/>	Fabricated U-shape				<input type="checkbox"/>	6" x 6" 0.054" (1.37mm) 50 ksi (340 MPa) Gusset Plate w/ S/HD15S Simpson		<input checked="" type="checkbox"/>		<input type="checkbox"/>	7" x 9" 0.054" (1.37mm) 50 ksi (340 MPa) Gusset Plate w/ S/HD15S Simpson				<input type="checkbox"/>	8" x 8" 0.068" (1.73mm) 50 ksi (340 MPa) Gusset Plate w/ S/HD15S Simpson				<input type="checkbox"/>	8.5" x 10" 0.068" (1.73mm) 50 ksi (340 MPa) Gusset Plate w/ S/HD15S Simpson				<input type="checkbox"/>	10" x 10" 0.054" (1.37mm) 50 ksi (340 MPa) Gusset Plate w/ S/HD15S Simpson			
<input checked="" type="checkbox"/>	S/HD10S Simpson	inside	outside	raised																																					
<input type="checkbox"/>	Fabricated U-shape																																								
<input type="checkbox"/>	6" x 6" 0.054" (1.37mm) 50 ksi (340 MPa) Gusset Plate w/ S/HD15S Simpson		<input checked="" type="checkbox"/>																																						
<input type="checkbox"/>	7" x 9" 0.054" (1.37mm) 50 ksi (340 MPa) Gusset Plate w/ S/HD15S Simpson																																								
<input type="checkbox"/>	8" x 8" 0.068" (1.73mm) 50 ksi (340 MPa) Gusset Plate w/ S/HD15S Simpson																																								
<input type="checkbox"/>	8.5" x 10" 0.068" (1.73mm) 50 ksi (340 MPa) Gusset Plate w/ S/HD15S Simpson																																								
<input type="checkbox"/>	10" x 10" 0.054" (1.37mm) 50 ksi (340 MPa) Gusset Plate w/ S/HD15S Simpson																																								
TEST PROTOCOL AND DESCRIPTION:	<input type="checkbox"/> Monotonic (Rate of Loading 2.5 mm/min) <input checked="" type="checkbox"/> Cyclic (CUREE cyclic protocol)																																								
LVDT MEASUREMENTS:	<input checked="" type="checkbox"/> Actuator LVDT <input checked="" type="checkbox"/> North Slip <input checked="" type="checkbox"/> South Slip		<input checked="" type="checkbox"/> North Uplift <input checked="" type="checkbox"/> South Uplift <input checked="" type="checkbox"/> Top of Wall		TOTAL: <input type="text" value="6"/>																																				
STRAP WIDTH BEFORE TEST:	<table border="1" style="width:100%; text-align: center;"> <tr> <td>Front Right</td> <td>Front Left, mm</td> <td>Back Right, mm</td> <td>Back Left, mm</td> </tr> <tr> <td>63.86</td> <td>63.11</td> <td>63.69</td> <td>63.78</td> </tr> <tr> <td>63.57</td> <td>63.67</td> <td>63.71</td> <td>63.82</td> </tr> <tr> <td>64.02</td> <td>64.12</td> <td>64.56</td> <td>64.91</td> </tr> <tr> <td>AVG</td> <td>63.82</td> <td>AVG</td> <td>63.99</td> </tr> <tr> <td></td> <td>mm</td> <td>AVG</td> <td>mm</td> </tr> <tr> <td></td> <td></td> <td>AVG</td> <td>64.17</td> </tr> <tr> <td></td> <td></td> <td></td> <td>mm</td> </tr> </table>						Front Right	Front Left, mm	Back Right, mm	Back Left, mm	63.86	63.11	63.69	63.78	63.57	63.67	63.71	63.82	64.02	64.12	64.56	64.91	AVG	63.82	AVG	63.99		mm	AVG	mm			AVG	64.17				mm			
Front Right	Front Left, mm	Back Right, mm	Back Left, mm																																						
63.86	63.11	63.69	63.78																																						
63.57	63.67	63.71	63.82																																						
64.02	64.12	64.56	64.91																																						
AVG	63.82	AVG	63.99																																						
	mm	AVG	mm																																						
		AVG	64.17																																						
			mm																																						
DATA ACQ. RECORD RATE:	100 scan/sec		MONITOR RATE:	100 scan/sec																																					
COMMENTS:	-Shear anchors torqued for 10 s with impact wrench -Hold down anchors 1/2 turn from finger tight (load cells used on both hold-downs) -Ambient temperature 28 C -Double chord studs used screwed back to back -Square plate washers (2.5"x2.5") used in all top track connections -Regular washers used in all bottom track connections																																								

Figure C. 9 Data sheet for test 32 A-C

Cold Formed Steel Strap Braced Walls McGill University, Montreal																																																								
TEST:	33 A-M																																																							
RESEARCHER:	Kostadin Velchev	ASSISTANTS:	Gilles Comeau, Nisreen Balh																																																					
DATE:	4-Jul-07		TIME:	16:50																																																				
DIMENSIONS OF WALL:	8 FT X	8 FT X	6 IN.	INITIAL STRAP SURVEY:	Front Back	Right tight tight	Left tight tight																																																	
STRAP FASTENER CONFIGURATION:				MFR:	McGill																																																			
STRAP SIZE:	<table border="0" style="width:100%;"> <tr><td><input type="checkbox"/></td><td>2.5" 0.043" (1.09mm) 33 ksi (230 MPa)</td></tr> <tr><td><input type="checkbox"/></td><td>2.75" 0.054" (1.37mm) 50 ksi (340 MPa)</td></tr> <tr><td><input type="checkbox"/></td><td>4" 0.068" (1.73mm) 50 ksi (340 MPa)</td></tr> <tr><td><input type="checkbox"/></td><td>5" 0.043" (1.09) 33 ksi (230 MPa)</td></tr> <tr><td><input type="checkbox"/></td><td>Reduced section strap -- fuse = 2.5" wide x 30" long -- ends = 3.75" wide 0.043" (1.09mm) 33 ksi (230 MPa)</td></tr> <tr><td><input type="checkbox"/></td><td>Reduced section strap -- fuse = 2.75" wide x 30" long -- ends = 4.25" wide 0.054" (1.37mm) 50 ksi (340 MPa)</td></tr> <tr><td><input type="checkbox"/></td><td>Reduced section strap -- fuse = 4" wide x 30" long -- ends = 6" wide 0.068" (1.73mm) 50 ksi (340 MPa)</td></tr> <tr><td><input type="checkbox"/></td><td>Reduced section strap -- fuse = 2.5" wide x 60" long -- ends = 3.75" wide 0.043" (1.09mm) 33 ksi (230 MPa)</td></tr> <tr><td><input checked="" type="checkbox"/></td><td>Reduced section strap -- fuse = 4" wide x 60" long -- ends = 6" wide 0.068" (1.73mm) 50 ksi (340 MPa)</td></tr> </table>							<input type="checkbox"/>	2.5" 0.043" (1.09mm) 33 ksi (230 MPa)	<input type="checkbox"/>	2.75" 0.054" (1.37mm) 50 ksi (340 MPa)	<input type="checkbox"/>	4" 0.068" (1.73mm) 50 ksi (340 MPa)	<input type="checkbox"/>	5" 0.043" (1.09) 33 ksi (230 MPa)	<input type="checkbox"/>	Reduced section strap -- fuse = 2.5" wide x 30" long -- ends = 3.75" wide 0.043" (1.09mm) 33 ksi (230 MPa)	<input type="checkbox"/>	Reduced section strap -- fuse = 2.75" wide x 30" long -- ends = 4.25" wide 0.054" (1.37mm) 50 ksi (340 MPa)	<input type="checkbox"/>	Reduced section strap -- fuse = 4" wide x 30" long -- ends = 6" wide 0.068" (1.73mm) 50 ksi (340 MPa)	<input type="checkbox"/>	Reduced section strap -- fuse = 2.5" wide x 60" long -- ends = 3.75" wide 0.043" (1.09mm) 33 ksi (230 MPa)	<input checked="" type="checkbox"/>	Reduced section strap -- fuse = 4" wide x 60" long -- ends = 6" wide 0.068" (1.73mm) 50 ksi (340 MPa)																															
<input type="checkbox"/>	2.5" 0.043" (1.09mm) 33 ksi (230 MPa)																																																							
<input type="checkbox"/>	2.75" 0.054" (1.37mm) 50 ksi (340 MPa)																																																							
<input type="checkbox"/>	4" 0.068" (1.73mm) 50 ksi (340 MPa)																																																							
<input type="checkbox"/>	5" 0.043" (1.09) 33 ksi (230 MPa)																																																							
<input type="checkbox"/>	Reduced section strap -- fuse = 2.5" wide x 30" long -- ends = 3.75" wide 0.043" (1.09mm) 33 ksi (230 MPa)																																																							
<input type="checkbox"/>	Reduced section strap -- fuse = 2.75" wide x 30" long -- ends = 4.25" wide 0.054" (1.37mm) 50 ksi (340 MPa)																																																							
<input type="checkbox"/>	Reduced section strap -- fuse = 4" wide x 30" long -- ends = 6" wide 0.068" (1.73mm) 50 ksi (340 MPa)																																																							
<input type="checkbox"/>	Reduced section strap -- fuse = 2.5" wide x 60" long -- ends = 3.75" wide 0.043" (1.09mm) 33 ksi (230 MPa)																																																							
<input checked="" type="checkbox"/>	Reduced section strap -- fuse = 4" wide x 60" long -- ends = 6" wide 0.068" (1.73mm) 50 ksi (340 MPa)																																																							
INTERIOR STUDS:	<table border="0" style="width:100%;"> <tr><td><input type="checkbox"/></td><td>3-5/8"Wx1-5/8"Fx1/2"Lip 0.043" (1.09mm) 33ksi (230 Mpa)</td></tr> <tr><td><input checked="" type="checkbox"/></td><td>6"Wx1-5/8"Fx1/2"Lip 0.043" (1.09mm) 33ksi (230 Mpa)</td></tr> </table>		<input type="checkbox"/>	3-5/8"Wx1-5/8"Fx1/2"Lip 0.043" (1.09mm) 33ksi (230 Mpa)	<input checked="" type="checkbox"/>	6"Wx1-5/8"Fx1/2"Lip 0.043" (1.09mm) 33ksi (230 Mpa)	STUD SPACING:	<table border="0" style="width:100%;"> <tr><td><input checked="" type="checkbox"/></td><td>16" O.C.</td></tr> <tr><td><input type="checkbox"/></td><td>Other : _____</td></tr> </table>			<input checked="" type="checkbox"/>	16" O.C.	<input type="checkbox"/>	Other : _____																																										
<input type="checkbox"/>	3-5/8"Wx1-5/8"Fx1/2"Lip 0.043" (1.09mm) 33ksi (230 Mpa)																																																							
<input checked="" type="checkbox"/>	6"Wx1-5/8"Fx1/2"Lip 0.043" (1.09mm) 33ksi (230 Mpa)																																																							
<input checked="" type="checkbox"/>	16" O.C.																																																							
<input type="checkbox"/>	Other : _____																																																							
BACK-TO-BACK CHORD STUDS:	<table border="0" style="width:100%;"> <tr><td><input type="checkbox"/></td><td>3-5/8"Wx1-5/8"Fx1/2"Lip 0.043" (1.09mm) 33ksi (230 Mpa)</td></tr> <tr><td><input type="checkbox"/></td><td>6"Wx1-5/8"Fx1/2"Lip 0.054" (1.37mm) 50ksi (345 Mpa)</td></tr> <tr><td><input checked="" type="checkbox"/></td><td>6"Wx1-5/8"Fx1/2"Lip 0.068" (1.73mm) 50ksi (345 Mpa)</td></tr> </table>							<input type="checkbox"/>	3-5/8"Wx1-5/8"Fx1/2"Lip 0.043" (1.09mm) 33ksi (230 Mpa)	<input type="checkbox"/>	6"Wx1-5/8"Fx1/2"Lip 0.054" (1.37mm) 50ksi (345 Mpa)	<input checked="" type="checkbox"/>	6"Wx1-5/8"Fx1/2"Lip 0.068" (1.73mm) 50ksi (345 Mpa)																																											
<input type="checkbox"/>	3-5/8"Wx1-5/8"Fx1/2"Lip 0.043" (1.09mm) 33ksi (230 Mpa)																																																							
<input type="checkbox"/>	6"Wx1-5/8"Fx1/2"Lip 0.054" (1.37mm) 50ksi (345 Mpa)																																																							
<input checked="" type="checkbox"/>	6"Wx1-5/8"Fx1/2"Lip 0.068" (1.73mm) 50ksi (345 Mpa)																																																							
CONNECTIONS:	<table border="0" style="width:100%;"> <tr><td>Straps:</td><td><input checked="" type="checkbox"/></td><td>No.10 gauge 0.75" self-drilling wafer head (mod. Truss) Phillips drive</td></tr> <tr><td>Framing:</td><td><input checked="" type="checkbox"/></td><td>No.8 gauge 0.5" self-drilling wafer head (mod. Truss) Phillips drive</td></tr> <tr><td>Hold downs:</td><td><input checked="" type="checkbox"/></td><td>No.14 gauge 0.1" self-drilling Hex washer head</td></tr> <tr><td>Back-to-Back:</td><td><input checked="" type="checkbox"/></td><td>No.14 gauge 0.1" self-drilling Hex washer head</td></tr> <tr><td>Chord Studs:</td><td><input checked="" type="checkbox"/></td><td>No.10 gauge 1" self-drilling Hex washer head</td></tr> <tr><td>Anchor Rods:</td><td><input type="checkbox"/></td><td>7/8" A307</td></tr> <tr><td></td><td><input checked="" type="checkbox"/></td><td>1" Rod</td></tr> <tr><td>Loading Beam:</td><td><input checked="" type="checkbox"/></td><td>A325 3/4" bolts</td></tr> <tr><td>Base:</td><td><input checked="" type="checkbox"/></td><td>A325 3/4" bolts</td></tr> </table>							Straps:	<input checked="" type="checkbox"/>	No.10 gauge 0.75" self-drilling wafer head (mod. Truss) Phillips drive	Framing:	<input checked="" type="checkbox"/>	No.8 gauge 0.5" self-drilling wafer head (mod. Truss) Phillips drive	Hold downs:	<input checked="" type="checkbox"/>	No.14 gauge 0.1" self-drilling Hex washer head	Back-to-Back:	<input checked="" type="checkbox"/>	No.14 gauge 0.1" self-drilling Hex washer head	Chord Studs:	<input checked="" type="checkbox"/>	No.10 gauge 1" self-drilling Hex washer head	Anchor Rods:	<input type="checkbox"/>	7/8" A307		<input checked="" type="checkbox"/>	1" Rod	Loading Beam:	<input checked="" type="checkbox"/>	A325 3/4" bolts	Base:	<input checked="" type="checkbox"/>	A325 3/4" bolts																						
Straps:	<input checked="" type="checkbox"/>	No.10 gauge 0.75" self-drilling wafer head (mod. Truss) Phillips drive																																																						
Framing:	<input checked="" type="checkbox"/>	No.8 gauge 0.5" self-drilling wafer head (mod. Truss) Phillips drive																																																						
Hold downs:	<input checked="" type="checkbox"/>	No.14 gauge 0.1" self-drilling Hex washer head																																																						
Back-to-Back:	<input checked="" type="checkbox"/>	No.14 gauge 0.1" self-drilling Hex washer head																																																						
Chord Studs:	<input checked="" type="checkbox"/>	No.10 gauge 1" self-drilling Hex washer head																																																						
Anchor Rods:	<input type="checkbox"/>	7/8" A307																																																						
	<input checked="" type="checkbox"/>	1" Rod																																																						
Loading Beam:	<input checked="" type="checkbox"/>	A325 3/4" bolts																																																						
Base:	<input checked="" type="checkbox"/>	A325 3/4" bolts																																																						
TRACK:	<table border="0" style="width:100%;"> <tr><td><input type="checkbox"/></td><td>Regular</td><td><input checked="" type="checkbox"/></td><td>6" web</td><td><input type="checkbox"/></td><td>0.043" (1.09mm) 33ksi (230 Mpa)</td></tr> <tr><td><input checked="" type="checkbox"/></td><td>Extended</td><td><input type="checkbox"/></td><td>3 5/8" web</td><td><input type="checkbox"/></td><td>0.054" (1.37mm) 50ksi (345 Mpa)</td></tr> <tr><td><input type="checkbox"/></td><td>Reinforced</td><td><input type="checkbox"/></td><td>1-1/4" flange</td><td><input checked="" type="checkbox"/></td><td>0.068" (1.73mm) 50ksi (345 Mpa)</td></tr> </table>							<input type="checkbox"/>	Regular	<input checked="" type="checkbox"/>	6" web	<input type="checkbox"/>	0.043" (1.09mm) 33ksi (230 Mpa)	<input checked="" type="checkbox"/>	Extended	<input type="checkbox"/>	3 5/8" web	<input type="checkbox"/>	0.054" (1.37mm) 50ksi (345 Mpa)	<input type="checkbox"/>	Reinforced	<input type="checkbox"/>	1-1/4" flange	<input checked="" type="checkbox"/>	0.068" (1.73mm) 50ksi (345 Mpa)																															
<input type="checkbox"/>	Regular	<input checked="" type="checkbox"/>	6" web	<input type="checkbox"/>	0.043" (1.09mm) 33ksi (230 Mpa)																																																			
<input checked="" type="checkbox"/>	Extended	<input type="checkbox"/>	3 5/8" web	<input type="checkbox"/>	0.054" (1.37mm) 50ksi (345 Mpa)																																																			
<input type="checkbox"/>	Reinforced	<input type="checkbox"/>	1-1/4" flange	<input checked="" type="checkbox"/>	0.068" (1.73mm) 50ksi (345 Mpa)																																																			
HOLD DOWNS:	<table border="0" style="width:100%;"> <tr><td><input type="checkbox"/></td><td>S/HD10S Simpson</td><td></td><td></td><td></td><td></td><td></td></tr> <tr><td><input type="checkbox"/></td><td>Fabricated U-shape</td><td></td><td></td><td></td><td></td><td></td></tr> <tr><td><input type="checkbox"/></td><td>6" x 6" 0.054" (1.37mm) 50 ksi (340 MPa) Gusset Plate w/ S/HD15S Simpson</td><td></td><td></td><td></td><td></td><td></td></tr> <tr><td><input type="checkbox"/></td><td>7" x 9" 0.054" (1.37mm) 50 ksi (340 MPa) Gusset Plate w/ S/HD15S Simpson</td><td></td><td></td><td></td><td></td><td></td></tr> <tr><td><input type="checkbox"/></td><td>8" x 8" 0.068" (1.73mm) 50 ksi (340 MPa) Gusset Plate w/ S/HD15S Simpson</td><td></td><td></td><td></td><td></td><td></td></tr> <tr><td><input checked="" type="checkbox"/></td><td>8.5" x 10" 0.068" (1.73mm) 50 ksi (340 MPa) Gusset Plate w/ S/HD15S Simpson</td><td></td><td></td><td></td><td></td><td></td></tr> <tr><td><input type="checkbox"/></td><td>10" x 10" 0.054" (1.37mm) 50 ksi (340 MPa) Gusset Plate w/ S/HD15S Simpson</td><td></td><td></td><td></td><td></td><td></td></tr> </table>							<input type="checkbox"/>	S/HD10S Simpson						<input type="checkbox"/>	Fabricated U-shape						<input type="checkbox"/>	6" x 6" 0.054" (1.37mm) 50 ksi (340 MPa) Gusset Plate w/ S/HD15S Simpson						<input type="checkbox"/>	7" x 9" 0.054" (1.37mm) 50 ksi (340 MPa) Gusset Plate w/ S/HD15S Simpson						<input type="checkbox"/>	8" x 8" 0.068" (1.73mm) 50 ksi (340 MPa) Gusset Plate w/ S/HD15S Simpson						<input checked="" type="checkbox"/>	8.5" x 10" 0.068" (1.73mm) 50 ksi (340 MPa) Gusset Plate w/ S/HD15S Simpson						<input type="checkbox"/>	10" x 10" 0.054" (1.37mm) 50 ksi (340 MPa) Gusset Plate w/ S/HD15S Simpson					
<input type="checkbox"/>	S/HD10S Simpson																																																							
<input type="checkbox"/>	Fabricated U-shape																																																							
<input type="checkbox"/>	6" x 6" 0.054" (1.37mm) 50 ksi (340 MPa) Gusset Plate w/ S/HD15S Simpson																																																							
<input type="checkbox"/>	7" x 9" 0.054" (1.37mm) 50 ksi (340 MPa) Gusset Plate w/ S/HD15S Simpson																																																							
<input type="checkbox"/>	8" x 8" 0.068" (1.73mm) 50 ksi (340 MPa) Gusset Plate w/ S/HD15S Simpson																																																							
<input checked="" type="checkbox"/>	8.5" x 10" 0.068" (1.73mm) 50 ksi (340 MPa) Gusset Plate w/ S/HD15S Simpson																																																							
<input type="checkbox"/>	10" x 10" 0.054" (1.37mm) 50 ksi (340 MPa) Gusset Plate w/ S/HD15S Simpson																																																							
TEST PROTOCOL AND DESCRIPTION:	<table border="0" style="width:100%;"> <tr><td><input checked="" type="checkbox"/></td><td>Monotonic (Rate of Loading 2.5 mm/min)</td></tr> <tr><td><input type="checkbox"/></td><td>Cyclic (CUREE cyclic protocol)</td></tr> </table>							<input checked="" type="checkbox"/>	Monotonic (Rate of Loading 2.5 mm/min)	<input type="checkbox"/>	Cyclic (CUREE cyclic protocol)																																													
<input checked="" type="checkbox"/>	Monotonic (Rate of Loading 2.5 mm/min)																																																							
<input type="checkbox"/>	Cyclic (CUREE cyclic protocol)																																																							
LVDT MEASUREMENTS:	<table border="0" style="width:100%;"> <tr><td><input checked="" type="checkbox"/></td><td>Actuator LVDT</td><td><input checked="" type="checkbox"/></td><td>North Uplift</td></tr> <tr><td><input checked="" type="checkbox"/></td><td>North Slip</td><td><input checked="" type="checkbox"/></td><td>South Uplift</td></tr> <tr><td><input checked="" type="checkbox"/></td><td>South Slip</td><td><input checked="" type="checkbox"/></td><td>Top of Wall</td></tr> </table>							<input checked="" type="checkbox"/>	Actuator LVDT	<input checked="" type="checkbox"/>	North Uplift	<input checked="" type="checkbox"/>	North Slip	<input checked="" type="checkbox"/>	South Uplift	<input checked="" type="checkbox"/>	South Slip	<input checked="" type="checkbox"/>	Top of Wall																																					
<input checked="" type="checkbox"/>	Actuator LVDT	<input checked="" type="checkbox"/>	North Uplift																																																					
<input checked="" type="checkbox"/>	North Slip	<input checked="" type="checkbox"/>	South Uplift																																																					
<input checked="" type="checkbox"/>	South Slip	<input checked="" type="checkbox"/>	Top of Wall																																																					
TOTAL: <input type="text" value="6"/>																																																								
STRAP WIDTH BEFORE TEST:	<table border="0" style="width:100%;"> <tr> <td style="text-align: center;">Front Right</td> <td style="text-align: center;">Front Left, mm</td> <td style="text-align: center;">Back Right, mm</td> <td style="text-align: center;">Back Left, mm</td> <td colspan="3"></td> </tr> <tr> <td style="text-align: center;">101.81</td> <td style="text-align: center;">102.88</td> <td style="text-align: center;">102.22</td> <td style="text-align: center;">101.93</td> <td colspan="3"></td> </tr> <tr> <td style="text-align: center;">101.87</td> <td style="text-align: center;">101.52</td> <td style="text-align: center;">102.08</td> <td style="text-align: center;">101.73</td> <td colspan="3"></td> </tr> <tr> <td style="text-align: center;">102.29</td> <td style="text-align: center;">102.34</td> <td style="text-align: center;">102.13</td> <td style="text-align: center;">101.83</td> <td colspan="3"></td> </tr> <tr> <td style="text-align: center;">AVG</td> <td style="text-align: center;">101.99</td> <td style="text-align: center;">AVG</td> <td style="text-align: center;">102.25</td> <td style="text-align: center;">mm</td> <td style="text-align: center;">AVG</td> <td style="text-align: center;">102.14</td> <td style="text-align: center;">mm</td> </tr> <tr> <td style="text-align: center;">AVG</td> <td style="text-align: center;">101.83</td> <td style="text-align: center;">AVG</td> <td style="text-align: center;">101.83</td> <td style="text-align: center;">mm</td> <td colspan="2"></td> </tr> </table>							Front Right	Front Left, mm	Back Right, mm	Back Left, mm				101.81	102.88	102.22	101.93				101.87	101.52	102.08	101.73				102.29	102.34	102.13	101.83				AVG	101.99	AVG	102.25	mm	AVG	102.14	mm	AVG	101.83	AVG	101.83	mm								
Front Right	Front Left, mm	Back Right, mm	Back Left, mm																																																					
101.81	102.88	102.22	101.93																																																					
101.87	101.52	102.08	101.73																																																					
102.29	102.34	102.13	101.83																																																					
AVG	101.99	AVG	102.25	mm	AVG	102.14	mm																																																	
AVG	101.83	AVG	101.83	mm																																																				
DATA ACQ. RECORD RATE:	1 scan/sec			MONITOR RATE:	10 scan/sec																																																			
COMMENTS:	<ul style="list-style-type: none"> -Shear anchors torqued for 10 s with impact wrench -Hold down anchors 1/2 turn from finger tight (load cells used on both hold-downs) -Ambient temperature 24 C -Double chord studs used screwed back to back -Square plate washers (2.5"x2.5") used in all top track connections -Regular washers used in all bottom track connections 																																																							

Figure C. 10 Data sheet for test 33 A-M

Cold Formed Steel Strap Braced Walls
McGill University, Montreal

TEST: 34 A-C

RESEARCHER: Kostadin Velchev **ASSISTANTS:** Gilles Comeau, Nisreen Balh

DATE: 30-Jul-07 **TIME:** 14:55

DIMENSIONS OF WALL: 8 FT X 8 FT X 6 IN. **INITIAL STRAP SURVEY:** Front Back Right tight loose Left tight loose

STRAP FASTENER CONFIGURATION: MFR: McGill

STRAP SIZE:

<input type="checkbox"/>	2.5" 0.043" (1.09mm) 33 ksi (230 MPa)
<input type="checkbox"/>	2.75" 0.054" (1.37mm) 50 ksi (340 MPa)
<input type="checkbox"/>	4" 0.068" (1.73mm) 50 ksi (340 MPa)
<input type="checkbox"/>	5" 0.043" (1.09) 33 ksi (230 MPa)
<input type="checkbox"/>	Reduced section strap -- fuse = 2.5" wide x 30" long -- ends = 3.75" wide 0.043" (1.09mm) 33 ksi (230 MPa)
<input type="checkbox"/>	Reduced section strap -- fuse = 2.75" wide x 30" long -- ends = 4.25" wide 0.054" (1.37mm) 50 ksi (340 MPa)
<input type="checkbox"/>	Reduced section strap -- fuse = 4" wide x 30" long -- ends = 6" wide 0.068" (1.73mm) 50 ksi (340 MPa)
<input type="checkbox"/>	Reduced section strap -- fuse = 2.5" wide x 60" long -- ends = 3.75" wide 0.043" (1.09mm) 33 ksi (230 MPa)
<input checked="" type="checkbox"/>	Reduced section strap -- fuse = 4" wide x 60" long -- ends = 6" wide 0.068" (1.73mm) 50 ksi (340 MPa)

INTERIOR STUDS:

<input type="checkbox"/>	3-5/8"Wx1-5/8"Fx1/2"Lip 0.043" (1.09mm) 33ksi (230 Mpa)
<input checked="" type="checkbox"/>	6"Wx1-5/8"Fx1/2"Lip 0.043" (1.09mm) 33ksi (230 Mpa)

STUD SPACING: 16" O.C. Other: _____

BACK-TO-BACK CHORD STUDS:

<input type="checkbox"/>	3-5/8"Wx1-5/8"Fx1/2"Lip 0.043" (1.09mm) 33ksi (230 Mpa)
<input type="checkbox"/>	6"Wx1-5/8"Fx1/2"Lip 0.054" (1.37mm) 50ksi (345 Mpa)
<input checked="" type="checkbox"/>	6"Wx1-5/8"Fx1/2"Lip 0.068" (1.73mm) 50ksi (345 Mpa)

CONNECTIONS:

<input checked="" type="checkbox"/>	Straps	No. 10 gauge 0.75" self-drilling wafer head (mod. Truss) Phillips drive
<input checked="" type="checkbox"/>	Framing:	No. 8 gauge 0.5" self-drilling wafer head (mod. Truss) Phillips drive
<input checked="" type="checkbox"/>	Hold downs:	No. 14 gauge 0.1" self-drilling Hex washer head
<input checked="" type="checkbox"/>	Back-to-Back	
<input checked="" type="checkbox"/>	Chord Studs:	No. 10 gauge 1" self-drilling Hex washer head
<input type="checkbox"/>	Anchor Rods:	7/8" A307
<input type="checkbox"/>		1" Rod
<input checked="" type="checkbox"/>	Loading Beam:	A325 3/4" bolts
<input checked="" type="checkbox"/>	Base:	A325 3/4" bolts

12 bolts 2 Anchor Rods
8 bolts 2 Anchor Rods

TRACK:

<input type="checkbox"/>	Regular	<input checked="" type="checkbox"/> 6" web	<input type="checkbox"/>	0.043" (1.09mm) 33ksi (230 Mpa)
<input checked="" type="checkbox"/>	Extended	3 5/8" web	<input type="checkbox"/>	0.054" (1.37mm) 50ksi (345 Mpa)
<input type="checkbox"/>	Reinforced	1-1/4" flange	<input checked="" type="checkbox"/>	0.068" (1.73mm) 50ksi (345 Mpa)

HOLD DOWNS:

<input type="checkbox"/>	S/HD10S Simpson	inside	outside	raised
<input type="checkbox"/>	Fabricated U-shape			
<input type="checkbox"/>	6" x 6" 0.054" (1.37mm) 50 ksi (340 MPa) Gusset Plate w/ S/HD15S Simpson			
<input type="checkbox"/>	7" x 9" 0.054" (1.37mm) 50 ksi (340 MPa) Gusset Plate w/ S/HD15S Simpson			
<input type="checkbox"/>	8" x 8" 0.068" (1.73mm) 50 ksi (340 MPa) Gusset Plate w/ S/HD15S Simpson			
<input checked="" type="checkbox"/>	8.5" x 10" 0.068" (1.73mm) 50 ksi (340 MPa) Gusset Plate w/ S/HD15S Simpson		<input checked="" type="checkbox"/>	
<input type="checkbox"/>	10" x 10" 0.054" (1.37mm) 50 ksi (340 MPa) Gusset Plate w/ S/HD15S Simpson			

TEST PROTOCOL AND DESCRIPTION:

<input type="checkbox"/>	Monotonic (Rate of Loading 2.5 mm/min)
<input checked="" type="checkbox"/>	Cyclic (CUREE cyclic protocol)

LVDT MEASUREMENTS:

<input checked="" type="checkbox"/>	Actuator LVDT	<input checked="" type="checkbox"/>	North Uplift
<input checked="" type="checkbox"/>	North Slip	<input checked="" type="checkbox"/>	South Uplift
<input checked="" type="checkbox"/>	South Slip	<input checked="" type="checkbox"/>	Top of Wall

TOTAL:

STRAP WIDTH BEFORE TEST:

Front Right	102.23	Front Left, mm	101.88	Back Right, mm	102.21	Back Left, mm	102.08
	101.81		101.71		102.10		101.76
	101.82		101.79		101.93		101.75
AVG	101.95	AVG	101.79 mm	AVG	102.08 mm	AVG	101.86 mm

DATA ACQ. RECORD RATE: 100 scan/sec **MONITOR RATE:** 100 scan/sec

COMMENTS:

- Shear anchors torqued for 10 s with impact wrench
- Hold down anchors 1/2 turn from finger tight (load cells used on both hold-downs)
- Ambient temperature 31C
- Double chord studs used screwed back to back
- Square plate washers (2.5"x2.5") used in all top track connections
- Regular washers used in all bottom track connections

Figure C. 11 Data sheet for test 34 A-C

Cold Formed Steel Strap Braced Walls																																						
McGill University, Montreal																																						
TEST:	35 A-M																																					
RESEARCHER:	Kostadin Velchev	ASSISTANTS:	Gilles Comeau, Nisreen Balh																																			
DATE:	4-Jun-07		TIME:	3:15pm																																		
DIMENSIONS OF WALL:	8 FT X	8 FT X	3-5/8 IN.	INITIAL STRAP SURVEY:	Front Back	Right tight loose	Left tight loose																															
STRAP FASTENER CONFIGURATION:				MFR: McGill																																		
STRAP SIZE:	<table border="1" style="width:100%; border-collapse: collapse;"> <tr><td><input checked="" type="checkbox"/></td><td>2.5" 0.043" (1.09mm) 33 ksi (230 MPa)</td></tr> <tr><td><input type="checkbox"/></td><td>2.75" 0.054" (1.37mm) 50 ksi (340 MPa)</td></tr> <tr><td><input type="checkbox"/></td><td>4" 0.068" (1.73mm) 50 ksi (340 MPa)</td></tr> <tr><td><input type="checkbox"/></td><td>5" 0.043" (1.09) 33 ksi (230 MPa)</td></tr> <tr><td><input type="checkbox"/></td><td>Reduced section strap -- fuse = 2.5" wide x 30" long -- ends = 3.75" wide 0.043" (1.09mm) 33 ksi (230 MPa)</td></tr> <tr><td><input type="checkbox"/></td><td>Reduced section strap -- fuse = 2.75" wide x 30" long -- ends = 4.25" wide 0.054" (1.37mm) 50 ksi (340 MPa)</td></tr> <tr><td><input type="checkbox"/></td><td>Reduced section strap -- fuse = 4" wide x 30" long -- ends = 6" wide 0.068" (1.73mm) 50 ksi (340 MPa)</td></tr> <tr><td><input type="checkbox"/></td><td>Reduced section strap -- fuse = 2.5" wide x 60" long -- ends = 3.75" wide 0.043" (1.09mm) 33 ksi (230 MPa)</td></tr> <tr><td><input type="checkbox"/></td><td>Reduced section strap -- fuse = 4" wide x 60" long -- ends = 6" wide 0.068" (1.73mm) 50 ksi (340 MPa)</td></tr> </table>			<input checked="" type="checkbox"/>	2.5" 0.043" (1.09mm) 33 ksi (230 MPa)	<input type="checkbox"/>	2.75" 0.054" (1.37mm) 50 ksi (340 MPa)	<input type="checkbox"/>	4" 0.068" (1.73mm) 50 ksi (340 MPa)	<input type="checkbox"/>	5" 0.043" (1.09) 33 ksi (230 MPa)	<input type="checkbox"/>	Reduced section strap -- fuse = 2.5" wide x 30" long -- ends = 3.75" wide 0.043" (1.09mm) 33 ksi (230 MPa)	<input type="checkbox"/>	Reduced section strap -- fuse = 2.75" wide x 30" long -- ends = 4.25" wide 0.054" (1.37mm) 50 ksi (340 MPa)	<input type="checkbox"/>	Reduced section strap -- fuse = 4" wide x 30" long -- ends = 6" wide 0.068" (1.73mm) 50 ksi (340 MPa)	<input type="checkbox"/>	Reduced section strap -- fuse = 2.5" wide x 60" long -- ends = 3.75" wide 0.043" (1.09mm) 33 ksi (230 MPa)	<input type="checkbox"/>	Reduced section strap -- fuse = 4" wide x 60" long -- ends = 6" wide 0.068" (1.73mm) 50 ksi (340 MPa)																	
<input checked="" type="checkbox"/>	2.5" 0.043" (1.09mm) 33 ksi (230 MPa)																																					
<input type="checkbox"/>	2.75" 0.054" (1.37mm) 50 ksi (340 MPa)																																					
<input type="checkbox"/>	4" 0.068" (1.73mm) 50 ksi (340 MPa)																																					
<input type="checkbox"/>	5" 0.043" (1.09) 33 ksi (230 MPa)																																					
<input type="checkbox"/>	Reduced section strap -- fuse = 2.5" wide x 30" long -- ends = 3.75" wide 0.043" (1.09mm) 33 ksi (230 MPa)																																					
<input type="checkbox"/>	Reduced section strap -- fuse = 2.75" wide x 30" long -- ends = 4.25" wide 0.054" (1.37mm) 50 ksi (340 MPa)																																					
<input type="checkbox"/>	Reduced section strap -- fuse = 4" wide x 30" long -- ends = 6" wide 0.068" (1.73mm) 50 ksi (340 MPa)																																					
<input type="checkbox"/>	Reduced section strap -- fuse = 2.5" wide x 60" long -- ends = 3.75" wide 0.043" (1.09mm) 33 ksi (230 MPa)																																					
<input type="checkbox"/>	Reduced section strap -- fuse = 4" wide x 60" long -- ends = 6" wide 0.068" (1.73mm) 50 ksi (340 MPa)																																					
INTERIOR STUDS:	<table border="1" style="width:100%; border-collapse: collapse;"> <tr><td><input checked="" type="checkbox"/></td><td>3-5/8"Wx1-5/8"Fx1/2"Lip 0.043" (1.09mm) 33ksi (230 Mpa)</td></tr> <tr><td><input type="checkbox"/></td><td>6"Wx1-5/8"Fx1/2"Lip 0.043" (1.09mm) 33ksi (230 Mpa)</td></tr> </table>		<input checked="" type="checkbox"/>	3-5/8"Wx1-5/8"Fx1/2"Lip 0.043" (1.09mm) 33ksi (230 Mpa)	<input type="checkbox"/>	6"Wx1-5/8"Fx1/2"Lip 0.043" (1.09mm) 33ksi (230 Mpa)	STUD SPACING:	<table border="1" style="width:100%; border-collapse: collapse;"> <tr><td><input checked="" type="checkbox"/></td><td>16" O.C.</td></tr> <tr><td><input type="checkbox"/></td><td>Other : _____</td></tr> </table>	<input checked="" type="checkbox"/>	16" O.C.	<input type="checkbox"/>	Other : _____																										
<input checked="" type="checkbox"/>	3-5/8"Wx1-5/8"Fx1/2"Lip 0.043" (1.09mm) 33ksi (230 Mpa)																																					
<input type="checkbox"/>	6"Wx1-5/8"Fx1/2"Lip 0.043" (1.09mm) 33ksi (230 Mpa)																																					
<input checked="" type="checkbox"/>	16" O.C.																																					
<input type="checkbox"/>	Other : _____																																					
BACK-TO-BACK CHORD STUDS:	<table border="1" style="width:100%; border-collapse: collapse;"> <tr><td><input checked="" type="checkbox"/></td><td>3-5/8"Wx1-5/8"Fx1/2"Lip 0.043" (1.09mm) 33ksi (230 Mpa)</td></tr> <tr><td><input type="checkbox"/></td><td>6"Wx1-5/8"Fx1/2"Lip 0.054" (1.37mm) 50ksi (345 Mpa)</td></tr> <tr><td><input type="checkbox"/></td><td>6"Wx1-5/8"Fx1/2"Lip 0.068" (1.73mm) 50ksi (345 Mpa)</td></tr> </table>			<input checked="" type="checkbox"/>	3-5/8"Wx1-5/8"Fx1/2"Lip 0.043" (1.09mm) 33ksi (230 Mpa)	<input type="checkbox"/>	6"Wx1-5/8"Fx1/2"Lip 0.054" (1.37mm) 50ksi (345 Mpa)	<input type="checkbox"/>	6"Wx1-5/8"Fx1/2"Lip 0.068" (1.73mm) 50ksi (345 Mpa)																													
<input checked="" type="checkbox"/>	3-5/8"Wx1-5/8"Fx1/2"Lip 0.043" (1.09mm) 33ksi (230 Mpa)																																					
<input type="checkbox"/>	6"Wx1-5/8"Fx1/2"Lip 0.054" (1.37mm) 50ksi (345 Mpa)																																					
<input type="checkbox"/>	6"Wx1-5/8"Fx1/2"Lip 0.068" (1.73mm) 50ksi (345 Mpa)																																					
CONNECTIONS:	<table border="1" style="width:100%; border-collapse: collapse;"> <tr><td><input checked="" type="checkbox"/></td><td>Straps</td><td>No.10 gauge 0.75" self-drilling wafer head (mod. Truss) Phillips drive</td></tr> <tr><td><input checked="" type="checkbox"/></td><td>Framing:</td><td>No.8 gauge 0.5" self-drilling wafer head (mod. Truss) Phillips drive</td></tr> <tr><td><input checked="" type="checkbox"/></td><td>Hold downs:</td><td>No.14 gauge3/4" self-drilling Hex washer head</td></tr> <tr><td><input checked="" type="checkbox"/></td><td>Back-to-Back</td><td></td></tr> <tr><td><input checked="" type="checkbox"/></td><td>Chord Studs:</td><td>No.10 gauge 0.75" self-drilling Hex washer head</td></tr> <tr><td><input type="checkbox"/></td><td>Anchor Rods</td><td>7/8" A307</td></tr> <tr><td><input type="checkbox"/></td><td></td><td>7/8" Rod</td></tr> <tr><td><input checked="" type="checkbox"/></td><td>Loading Beam:</td><td>A325 3/4" bolts</td></tr> <tr><td><input checked="" type="checkbox"/></td><td>Base</td><td>A325 3/4" bolts</td></tr> </table>			<input checked="" type="checkbox"/>	Straps	No.10 gauge 0.75" self-drilling wafer head (mod. Truss) Phillips drive	<input checked="" type="checkbox"/>	Framing:	No.8 gauge 0.5" self-drilling wafer head (mod. Truss) Phillips drive	<input checked="" type="checkbox"/>	Hold downs:	No.14 gauge3/4" self-drilling Hex washer head	<input checked="" type="checkbox"/>	Back-to-Back		<input checked="" type="checkbox"/>	Chord Studs:	No.10 gauge 0.75" self-drilling Hex washer head	<input type="checkbox"/>	Anchor Rods	7/8" A307	<input type="checkbox"/>		7/8" Rod	<input checked="" type="checkbox"/>	Loading Beam:	A325 3/4" bolts	<input checked="" type="checkbox"/>	Base	A325 3/4" bolts								
<input checked="" type="checkbox"/>	Straps	No.10 gauge 0.75" self-drilling wafer head (mod. Truss) Phillips drive																																				
<input checked="" type="checkbox"/>	Framing:	No.8 gauge 0.5" self-drilling wafer head (mod. Truss) Phillips drive																																				
<input checked="" type="checkbox"/>	Hold downs:	No.14 gauge3/4" self-drilling Hex washer head																																				
<input checked="" type="checkbox"/>	Back-to-Back																																					
<input checked="" type="checkbox"/>	Chord Studs:	No.10 gauge 0.75" self-drilling Hex washer head																																				
<input type="checkbox"/>	Anchor Rods	7/8" A307																																				
<input type="checkbox"/>		7/8" Rod																																				
<input checked="" type="checkbox"/>	Loading Beam:	A325 3/4" bolts																																				
<input checked="" type="checkbox"/>	Base	A325 3/4" bolts																																				
TRACK:	<table border="1" style="width:100%; border-collapse: collapse;"> <tr><td><input type="checkbox"/></td><td>Regular</td><td><input type="checkbox"/></td><td>6" web</td><td><input checked="" type="checkbox"/></td><td>0.043" (1.09mm) 33ksi (230 Mpa)</td></tr> <tr><td><input checked="" type="checkbox"/></td><td>Extended</td><td><input checked="" type="checkbox"/></td><td>3 5/8" web</td><td><input type="checkbox"/></td><td>0.054" (1.37mm) 50ksi (345 Mpa)</td></tr> <tr><td><input type="checkbox"/></td><td>Reinforced</td><td><input type="checkbox"/></td><td>1-1/4" flange</td><td><input type="checkbox"/></td><td>0.068" (1.73mm) 50ksi (345 Mpa)</td></tr> </table>			<input type="checkbox"/>	Regular	<input type="checkbox"/>	6" web	<input checked="" type="checkbox"/>	0.043" (1.09mm) 33ksi (230 Mpa)	<input checked="" type="checkbox"/>	Extended	<input checked="" type="checkbox"/>	3 5/8" web	<input type="checkbox"/>	0.054" (1.37mm) 50ksi (345 Mpa)	<input type="checkbox"/>	Reinforced	<input type="checkbox"/>	1-1/4" flange	<input type="checkbox"/>	0.068" (1.73mm) 50ksi (345 Mpa)																	
<input type="checkbox"/>	Regular	<input type="checkbox"/>	6" web	<input checked="" type="checkbox"/>	0.043" (1.09mm) 33ksi (230 Mpa)																																	
<input checked="" type="checkbox"/>	Extended	<input checked="" type="checkbox"/>	3 5/8" web	<input type="checkbox"/>	0.054" (1.37mm) 50ksi (345 Mpa)																																	
<input type="checkbox"/>	Reinforced	<input type="checkbox"/>	1-1/4" flange	<input type="checkbox"/>	0.068" (1.73mm) 50ksi (345 Mpa)																																	
HOLD DOWNS:	<table border="1" style="width:100%; border-collapse: collapse;"> <tr><td><input checked="" type="checkbox"/></td><td>S/HD10S Simpson</td><td>inside</td><td>outside</td><td>raised</td></tr> <tr><td><input type="checkbox"/></td><td>Fabricated U-shape</td><td><input checked="" type="checkbox"/></td><td><input type="checkbox"/></td><td><input checked="" type="checkbox"/></td></tr> <tr><td><input type="checkbox"/></td><td>6" x 6" 0.054" (1.37mm) 50 ksi (340 MPa) Gusset Plate w/ S/HD15S Simpson</td><td></td><td></td><td></td></tr> <tr><td><input type="checkbox"/></td><td>7" x 9" 0.054" (1.37mm) 50 ksi (340 MPa) Gusset Plate w/ S/HD15S Simpson</td><td></td><td></td><td></td></tr> <tr><td><input type="checkbox"/></td><td>8" x 8" 0.068" (1.73mm) 50 ksi (340 MPa) Gusset Plate w/ S/HD15S Simpson</td><td></td><td></td><td></td></tr> <tr><td><input type="checkbox"/></td><td>8.5" x10" 0.068" (1.73mm) 50 ksi (340 MPa) Gusset Plate w/ S/HD15S Simpson</td><td></td><td></td><td></td></tr> <tr><td><input type="checkbox"/></td><td>10" x10" 0.054" (1.37mm) 50 ksi (340 MPa) Gusset Plate w/ S/HD15S Simpson</td><td></td><td></td><td></td></tr> </table>			<input checked="" type="checkbox"/>	S/HD10S Simpson	inside	outside	raised	<input type="checkbox"/>	Fabricated U-shape	<input checked="" type="checkbox"/>	<input type="checkbox"/>	<input checked="" type="checkbox"/>	<input type="checkbox"/>	6" x 6" 0.054" (1.37mm) 50 ksi (340 MPa) Gusset Plate w/ S/HD15S Simpson				<input type="checkbox"/>	7" x 9" 0.054" (1.37mm) 50 ksi (340 MPa) Gusset Plate w/ S/HD15S Simpson				<input type="checkbox"/>	8" x 8" 0.068" (1.73mm) 50 ksi (340 MPa) Gusset Plate w/ S/HD15S Simpson				<input type="checkbox"/>	8.5" x10" 0.068" (1.73mm) 50 ksi (340 MPa) Gusset Plate w/ S/HD15S Simpson				<input type="checkbox"/>	10" x10" 0.054" (1.37mm) 50 ksi (340 MPa) Gusset Plate w/ S/HD15S Simpson			
<input checked="" type="checkbox"/>	S/HD10S Simpson	inside	outside	raised																																		
<input type="checkbox"/>	Fabricated U-shape	<input checked="" type="checkbox"/>	<input type="checkbox"/>	<input checked="" type="checkbox"/>																																		
<input type="checkbox"/>	6" x 6" 0.054" (1.37mm) 50 ksi (340 MPa) Gusset Plate w/ S/HD15S Simpson																																					
<input type="checkbox"/>	7" x 9" 0.054" (1.37mm) 50 ksi (340 MPa) Gusset Plate w/ S/HD15S Simpson																																					
<input type="checkbox"/>	8" x 8" 0.068" (1.73mm) 50 ksi (340 MPa) Gusset Plate w/ S/HD15S Simpson																																					
<input type="checkbox"/>	8.5" x10" 0.068" (1.73mm) 50 ksi (340 MPa) Gusset Plate w/ S/HD15S Simpson																																					
<input type="checkbox"/>	10" x10" 0.054" (1.37mm) 50 ksi (340 MPa) Gusset Plate w/ S/HD15S Simpson																																					
TEST PROTOCOL AND DESCRIPTION:	<table border="1" style="width:100%; border-collapse: collapse;"> <tr><td><input checked="" type="checkbox"/></td><td>Monotonic (Rate of Loading 2.5 mm/min)</td></tr> <tr><td><input type="checkbox"/></td><td>Cyclic (CUREE cyclic protocol)</td></tr> </table>			<input checked="" type="checkbox"/>	Monotonic (Rate of Loading 2.5 mm/min)	<input type="checkbox"/>	Cyclic (CUREE cyclic protocol)																															
<input checked="" type="checkbox"/>	Monotonic (Rate of Loading 2.5 mm/min)																																					
<input type="checkbox"/>	Cyclic (CUREE cyclic protocol)																																					
LVDT MEASUREMENTS:	<table border="1" style="width:100%; border-collapse: collapse;"> <tr><td><input checked="" type="checkbox"/></td><td>Actuator LVDT</td><td><input checked="" type="checkbox"/></td><td>North Uplift</td></tr> <tr><td><input checked="" type="checkbox"/></td><td>North Slip</td><td><input checked="" type="checkbox"/></td><td>South Uplift</td></tr> <tr><td><input checked="" type="checkbox"/></td><td>South Slip</td><td><input checked="" type="checkbox"/></td><td>Top of Wall</td></tr> </table>			<input checked="" type="checkbox"/>	Actuator LVDT	<input checked="" type="checkbox"/>	North Uplift	<input checked="" type="checkbox"/>	North Slip	<input checked="" type="checkbox"/>	South Uplift	<input checked="" type="checkbox"/>	South Slip	<input checked="" type="checkbox"/>	Top of Wall																							
<input checked="" type="checkbox"/>	Actuator LVDT	<input checked="" type="checkbox"/>	North Uplift																																			
<input checked="" type="checkbox"/>	North Slip	<input checked="" type="checkbox"/>	South Uplift																																			
<input checked="" type="checkbox"/>	South Slip	<input checked="" type="checkbox"/>	Top of Wall																																			
TOTAL: <input type="text" value="6"/>																																						
STRAP WIDTH BEFORE TEST:	<table border="1" style="width:100%; border-collapse: collapse;"> <tr> <td style="text-align: center;">Front Right</td> <td style="text-align: center;">Front Left, mm</td> <td style="text-align: center;">Back Right, mm</td> <td style="text-align: center;">Back Left, mm</td> </tr> <tr> <td style="text-align: center;"><input type="text"/></td> <td style="text-align: center;"><input type="text" value="62.49"/></td> <td style="text-align: center;"><input type="text" value="62.51"/></td> <td style="text-align: center;"><input type="text"/></td> </tr> <tr> <td style="text-align: center;"><input type="text"/></td> <td style="text-align: center;"><input type="text" value="64.01"/></td> <td style="text-align: center;"><input type="text" value="63.62"/></td> <td style="text-align: center;"><input type="text"/></td> </tr> <tr> <td style="text-align: center;"><input type="text"/></td> <td style="text-align: center;"><input type="text" value="64.06"/></td> <td style="text-align: center;"><input type="text" value="63.96"/></td> <td style="text-align: center;"><input type="text"/></td> </tr> <tr> <td style="text-align: center;">AVG</td> <td style="text-align: center;"><input type="text" value="0.00"/></td> <td style="text-align: center;">AVG</td> <td style="text-align: center;"><input type="text" value="63.52 mm"/></td> </tr> <tr> <td></td> <td></td> <td style="text-align: center;">AVG</td> <td style="text-align: center;"><input type="text" value="63.36 mm"/></td> </tr> <tr> <td></td> <td></td> <td></td> <td style="text-align: center;">AVG</td> <td style="text-align: center;"><input type="text" value="0.00 mm"/></td> </tr> </table>			Front Right	Front Left, mm	Back Right, mm	Back Left, mm	<input type="text"/>	<input type="text" value="62.49"/>	<input type="text" value="62.51"/>	<input type="text"/>	<input type="text"/>	<input type="text" value="64.01"/>	<input type="text" value="63.62"/>	<input type="text"/>	<input type="text"/>	<input type="text" value="64.06"/>	<input type="text" value="63.96"/>	<input type="text"/>	AVG	<input type="text" value="0.00"/>	AVG	<input type="text" value="63.52 mm"/>			AVG	<input type="text" value="63.36 mm"/>				AVG	<input type="text" value="0.00 mm"/>						
Front Right	Front Left, mm	Back Right, mm	Back Left, mm																																			
<input type="text"/>	<input type="text" value="62.49"/>	<input type="text" value="62.51"/>	<input type="text"/>																																			
<input type="text"/>	<input type="text" value="64.01"/>	<input type="text" value="63.62"/>	<input type="text"/>																																			
<input type="text"/>	<input type="text" value="64.06"/>	<input type="text" value="63.96"/>	<input type="text"/>																																			
AVG	<input type="text" value="0.00"/>	AVG	<input type="text" value="63.52 mm"/>																																			
		AVG	<input type="text" value="63.36 mm"/>																																			
			AVG	<input type="text" value="0.00 mm"/>																																		
DATA ACQ. RECORD RATE:	1 scan/sec		MONITOR RATE:	10 scan/sec																																		
COMMENTS:	<ul style="list-style-type: none"> -Shear anchors torqued for 10 s with impact wrench -Hold down anchors 1/2 turn from finger tight (load cells used on both hold-downs) -Ambient temperature 27 C -Double chord studs used screwed back to back -Square plate washers (2.5"x2.5") used in all top track connections -Regular washers used in all bottom track connections 																																					

Figure C. 12 Data sheet for test 35 A-M

Cold Formed Steel Strap Braced Walls
McGill University, Montreal

TEST: 36 A-C

RESEARCHER: Kostadin Velchev **ASSISTANTS:** Gilles Comeau, Nisreen Balh

DATE: 25-Jul-07 **TIME:** 16:37

DIMENSIONS OF WALL: 8 FT X 8 FT X 3-5/8 IN. **INITIAL STRAP SURVEY:** Front Right Left
Back tight tight
tight tight

STRAP FASTENER CONFIGURATION: MFR: McGill

STRAP SIZE:

<input checked="" type="checkbox"/>	2.5" 0.043" (1.09mm) 33 ksi (230 MPa)
<input type="checkbox"/>	2.75" 0.054" (1.37mm) 50 ksi (340 MPa)
<input type="checkbox"/>	4" 0.068" (1.73mm) 50 ksi (340 MPa)
<input type="checkbox"/>	5" 0.043" (1.09) 33 ksi (230 MPa)
<input type="checkbox"/>	Reduced section strap -- fuse = 2.5" wide x 30" long -- ends = 3.75" wide 0.043" (1.09mm) 33 ksi (230 MPa)
<input type="checkbox"/>	Reduced section strap -- fuse = 2.75" wide x 30" long -- ends = 4.25" wide 0.054" (1.37mm) 50 ksi (340 MPa)
<input type="checkbox"/>	Reduced section strap -- fuse = 4" wide x 30" long -- ends = 6" wide 0.068" (1.73mm) 50 ksi (340 MPa)
<input type="checkbox"/>	Reduced section strap -- fuse = 2.5" wide x 60" long -- ends = 3.75" wide 0.043" (1.09mm) 33 ksi (230 MPa)
<input type="checkbox"/>	Reduced section strap -- fuse = 4" wide x 60" long -- ends = 6" wide 0.068" (1.73mm) 50 ksi (340 MPa)

INTERIOR STUDS:

<input checked="" type="checkbox"/>	3-5/8"Wx1-5/8"Fx1/2"Lip 0.043" (1.09mm) 33ksi (230 Mpa)
<input type="checkbox"/>	6"Wx1-5/8"Fx1/2"Lip 0.043" (1.09mm) 33ksi (230 Mpa)

STUD SPACING: 16" O.C. Other: _____

BACK-TO-BACK CHORD STUDS:

<input checked="" type="checkbox"/>	3-5/8"Wx1-5/8"Fx1/2"Lip 0.043" (1.09mm) 33ksi (230 Mpa)
<input type="checkbox"/>	6"Wx1-5/8"Fx1/2"Lip 0.054" (1.37mm) 50ksi (345 Mpa)
<input type="checkbox"/>	6"Wx1-5/8"Fx1/2"Lip 0.068" (1.73mm) 50ksi (345 Mpa)

CONNECTIONS:

<input checked="" type="checkbox"/>	Straps	No.10 gauge 0.75" self-drilling wafer head (mod. Truss) Phillips drive
<input checked="" type="checkbox"/>	Framing:	No.8 gauge 0.5" self-drilling wafer head (mod. Truss) Phillips drive
<input checked="" type="checkbox"/>	Hold downs:	No.14 gauge 3/4" self-drilling Hex washer head
<input checked="" type="checkbox"/>	Back-to-Back	
<input checked="" type="checkbox"/>	Chord Studs:	No.10 gauge 0.75" self-drilling Hex washer head
<input type="checkbox"/>	Anchor Rods:	7/8" A307
<input type="checkbox"/>		7/8" Rod
<input checked="" type="checkbox"/>	Loading Beam:	A325 3/4" bolts
<input checked="" type="checkbox"/>	Base:	A325 3/4" bolts

12 bolts 2 Anchor Rods
8 bolts 2 Anchor Rods

TRACK:

<input type="checkbox"/>	Regular	6" web	<input checked="" type="checkbox"/>	0.043" (1.09mm) 33ksi (230 Mpa)
<input checked="" type="checkbox"/>	Extended	3 5/8" web	<input type="checkbox"/>	0.054" (1.37mm) 50ksi (345 Mpa)
<input type="checkbox"/>	Reinforced	1-1/4" flange	<input type="checkbox"/>	0.068" (1.73mm) 50ksi (345 Mpa)

HOLD DOWNS:

<input checked="" type="checkbox"/>	S/HD10S Simpson	inside	outside	raised
<input type="checkbox"/>	Fabricated U-shape		<input checked="" type="checkbox"/>	<input checked="" type="checkbox"/>
<input type="checkbox"/>	6" x 6" 0.054" (1.37mm) 50 ksi (340 MPa) Gusset Plate w/ S/HD15S Simpson			
<input type="checkbox"/>	7" x 9" 0.054" (1.37mm) 50 ksi (340 MPa) Gusset Plate w/ S/HD15S Simpson			
<input type="checkbox"/>	8" x 8" 0.068" (1.73mm) 50 ksi (340 MPa) Gusset Plate w/ S/HD15S Simpson			
<input type="checkbox"/>	8.5" x 10" 0.068" (1.73mm) 50 ksi (340 MPa) Gusset Plate w/ S/HD15S Simpson			
<input type="checkbox"/>	10" x 10" 0.054" (1.37mm) 50 ksi (340 MPa) Gusset Plate w/ S/HD15S Simpson			

TEST PROTOCOL AND DESCRIPTION:

<input type="checkbox"/>	Monotonic (Rate of Loading 2.5 mm/min)
<input checked="" type="checkbox"/>	Cyclic (CUREE cyclic protocol)

LVDT MEASUREMENTS:

<input checked="" type="checkbox"/>	Actuator LVDT	<input checked="" type="checkbox"/>	North Uplift
<input checked="" type="checkbox"/>	North Slip	<input checked="" type="checkbox"/>	South Uplift
<input checked="" type="checkbox"/>	South Slip	<input checked="" type="checkbox"/>	Top of Wall

TOTAL:

STRAP WIDTH BEFORE TEST:

Front Right	63.72	Front Left, mm	63.41	Back Right, mm	63.38	Back Left, mm	63.29
	63.4		63.32		63.40		63.37
	63.52		63.61		63.65		63.65
AVG	63.55	AVG	63.45 mm	AVG	63.48 mm	AVG	63.44 mm

DATA ACQ. RECORD RATE: 100 scan/sec **MONITOR RATE:** 100 scan/sec

COMMENTS:

- Shear anchors torqued for 10 s with impact wrench
- Hold down anchors 1/2 turn from finger tight (load cells used on both hold-downs)
- Ambient temperature 31C
- Double chord studs used screwed back to back
- Square plate washers (2.5"x2.5") used in all top track connections
- Regular washers used in all bottom track connections

Figure C. 13 Data sheet for test 36 A-C

Cold Formed Steel Strap Braced Walls McGill University, Montreal																																										
TEST:	37 A-M																																									
RESEARCHER:	Kostadin Velchev	ASSISTANTS:	Gilles Comeau, Nisreen Balh																																							
DATE:	23-May-07		TIME:	2.31pm																																						
DIMENSIONS OF WALL:	8 FT X	8 FT X	6 IN.	INITIAL STRAP SURVEY:	Front Back	Right loose tight	Left tight																																			
STRAP FASTENER CONFIGURATION:				MFR:	McGill																																					
STRAP SIZE:	<table border="0" style="width:100%;"> <tr><td><input type="checkbox"/></td><td>2.5" 0.043" (1.09mm) 33 ksi (230 MPa)</td></tr> <tr><td><input type="checkbox"/></td><td>2.75" 0.054" (1.37mm) 50 ksi (340 MPa)</td></tr> <tr><td><input checked="" type="checkbox"/></td><td>4" 0.068" (1.73mm) 50 ksi (340 MPa)</td></tr> <tr><td><input type="checkbox"/></td><td>5" 0.043" (1.09) 33 ksi (230 MPa)</td></tr> <tr><td><input type="checkbox"/></td><td>Reduced section strap -- fuse = 2.5" wide x 30" long -- ends = 3.75" wide 0.043" (1.09mm) 33 ksi (230 MPa)</td></tr> <tr><td><input type="checkbox"/></td><td>Reduced section strap -- fuse = 2.75" wide x 30" long -- ends = 4.25" wide 0.054" (1.37mm) 50 ksi (340 MPa)</td></tr> <tr><td><input type="checkbox"/></td><td>Reduced section strap -- fuse = 4" wide x 30" long -- ends = 6" wide 0.068" (1.73mm) 50 ksi (340 MPa)</td></tr> <tr><td><input type="checkbox"/></td><td>Reduced section strap -- fuse = 2.5" wide x 60" long -- ends = 3.75" wide 0.043" (1.09mm) 33 ksi (230 MPa)</td></tr> <tr><td><input type="checkbox"/></td><td>Reduced section strap -- fuse = 4" wide x 60" long -- ends = 6" wide 0.068" (1.73mm) 50 ksi (340 MPa)</td></tr> </table>							<input type="checkbox"/>	2.5" 0.043" (1.09mm) 33 ksi (230 MPa)	<input type="checkbox"/>	2.75" 0.054" (1.37mm) 50 ksi (340 MPa)	<input checked="" type="checkbox"/>	4" 0.068" (1.73mm) 50 ksi (340 MPa)	<input type="checkbox"/>	5" 0.043" (1.09) 33 ksi (230 MPa)	<input type="checkbox"/>	Reduced section strap -- fuse = 2.5" wide x 30" long -- ends = 3.75" wide 0.043" (1.09mm) 33 ksi (230 MPa)	<input type="checkbox"/>	Reduced section strap -- fuse = 2.75" wide x 30" long -- ends = 4.25" wide 0.054" (1.37mm) 50 ksi (340 MPa)	<input type="checkbox"/>	Reduced section strap -- fuse = 4" wide x 30" long -- ends = 6" wide 0.068" (1.73mm) 50 ksi (340 MPa)	<input type="checkbox"/>	Reduced section strap -- fuse = 2.5" wide x 60" long -- ends = 3.75" wide 0.043" (1.09mm) 33 ksi (230 MPa)	<input type="checkbox"/>	Reduced section strap -- fuse = 4" wide x 60" long -- ends = 6" wide 0.068" (1.73mm) 50 ksi (340 MPa)																	
<input type="checkbox"/>	2.5" 0.043" (1.09mm) 33 ksi (230 MPa)																																									
<input type="checkbox"/>	2.75" 0.054" (1.37mm) 50 ksi (340 MPa)																																									
<input checked="" type="checkbox"/>	4" 0.068" (1.73mm) 50 ksi (340 MPa)																																									
<input type="checkbox"/>	5" 0.043" (1.09) 33 ksi (230 MPa)																																									
<input type="checkbox"/>	Reduced section strap -- fuse = 2.5" wide x 30" long -- ends = 3.75" wide 0.043" (1.09mm) 33 ksi (230 MPa)																																									
<input type="checkbox"/>	Reduced section strap -- fuse = 2.75" wide x 30" long -- ends = 4.25" wide 0.054" (1.37mm) 50 ksi (340 MPa)																																									
<input type="checkbox"/>	Reduced section strap -- fuse = 4" wide x 30" long -- ends = 6" wide 0.068" (1.73mm) 50 ksi (340 MPa)																																									
<input type="checkbox"/>	Reduced section strap -- fuse = 2.5" wide x 60" long -- ends = 3.75" wide 0.043" (1.09mm) 33 ksi (230 MPa)																																									
<input type="checkbox"/>	Reduced section strap -- fuse = 4" wide x 60" long -- ends = 6" wide 0.068" (1.73mm) 50 ksi (340 MPa)																																									
INTERIOR STUDS:	<input type="checkbox"/> 3-5/8"Wx1-5/8"Fx1/2"Lip 0.043" (1.09mm) 33ksi (230 Mpa) <input checked="" type="checkbox"/> 6"Wx1-5/8"Fx1/2"Lip 0.043" (1.09mm) 33ksi (230 Mpa)		STUD SPACING:	<input checked="" type="checkbox"/> 16" O.C. <input type="checkbox"/> Other : _____																																						
BACK-TO-BACK CHORD STUDS:	<input type="checkbox"/> 3-5/8"Wx1-5/8"Fx1/2"Lip 0.043" (1.09mm) 33ksi (230 Mpa) <input type="checkbox"/> 6"Wx1-5/8"Fx1/2"Lip 0.054" (1.37mm) 50ksi (345 Mpa) <input checked="" type="checkbox"/> 6"Wx1-5/8"Fx1/2"Lip 0.068" (1.73mm) 50ksi (345 Mpa)																																									
CONNECTIONS:	<table border="0" style="width:100%;"> <tr><td>Straps:</td><td><input checked="" type="checkbox"/></td><td>No.10 gauge 0.75" self-drilling wafer head (mod. Truss) Phillips drive</td></tr> <tr><td>Framing:</td><td><input checked="" type="checkbox"/></td><td>No.8 gauge 0.5" self-drilling wafer head (mod. Truss) Phillips drive</td></tr> <tr><td>Hold downs:</td><td><input checked="" type="checkbox"/></td><td>No.14 gauge 1" self-drilling Hex washer head</td></tr> <tr><td>Back-to-Back:</td><td><input checked="" type="checkbox"/></td><td>No.14 gauge 1" self-drilling Hex washer head</td></tr> <tr><td>Chord Studs:</td><td><input checked="" type="checkbox"/></td><td>No.10 gauge 0.75" self-drilling Hex washer head</td></tr> <tr><td>Anchor Rods:</td><td><input type="checkbox"/></td><td>7/8" A307</td></tr> <tr><td></td><td><input checked="" type="checkbox"/></td><td>1" Rod</td></tr> <tr><td>Loading Beam:</td><td><input checked="" type="checkbox"/></td><td>A325 3/4" bolts</td></tr> <tr><td>Base:</td><td><input checked="" type="checkbox"/></td><td>A325 3/4" bolts</td></tr> </table> <table border="0" style="width:100%; margin-top: 5px;"> <tr> <td>12 bolts</td><td><input checked="" type="checkbox"/></td> <td>2 Anchor Rods</td><td><input checked="" type="checkbox"/></td> </tr> <tr> <td>8 bolts</td><td><input checked="" type="checkbox"/></td> <td>2 Anchor Rods</td><td><input checked="" type="checkbox"/></td> </tr> </table>							Straps:	<input checked="" type="checkbox"/>	No.10 gauge 0.75" self-drilling wafer head (mod. Truss) Phillips drive	Framing:	<input checked="" type="checkbox"/>	No.8 gauge 0.5" self-drilling wafer head (mod. Truss) Phillips drive	Hold downs:	<input checked="" type="checkbox"/>	No.14 gauge 1" self-drilling Hex washer head	Back-to-Back:	<input checked="" type="checkbox"/>	No.14 gauge 1" self-drilling Hex washer head	Chord Studs:	<input checked="" type="checkbox"/>	No.10 gauge 0.75" self-drilling Hex washer head	Anchor Rods:	<input type="checkbox"/>	7/8" A307		<input checked="" type="checkbox"/>	1" Rod	Loading Beam:	<input checked="" type="checkbox"/>	A325 3/4" bolts	Base:	<input checked="" type="checkbox"/>	A325 3/4" bolts	12 bolts	<input checked="" type="checkbox"/>	2 Anchor Rods	<input checked="" type="checkbox"/>	8 bolts	<input checked="" type="checkbox"/>	2 Anchor Rods	<input checked="" type="checkbox"/>
Straps:	<input checked="" type="checkbox"/>	No.10 gauge 0.75" self-drilling wafer head (mod. Truss) Phillips drive																																								
Framing:	<input checked="" type="checkbox"/>	No.8 gauge 0.5" self-drilling wafer head (mod. Truss) Phillips drive																																								
Hold downs:	<input checked="" type="checkbox"/>	No.14 gauge 1" self-drilling Hex washer head																																								
Back-to-Back:	<input checked="" type="checkbox"/>	No.14 gauge 1" self-drilling Hex washer head																																								
Chord Studs:	<input checked="" type="checkbox"/>	No.10 gauge 0.75" self-drilling Hex washer head																																								
Anchor Rods:	<input type="checkbox"/>	7/8" A307																																								
	<input checked="" type="checkbox"/>	1" Rod																																								
Loading Beam:	<input checked="" type="checkbox"/>	A325 3/4" bolts																																								
Base:	<input checked="" type="checkbox"/>	A325 3/4" bolts																																								
12 bolts	<input checked="" type="checkbox"/>	2 Anchor Rods	<input checked="" type="checkbox"/>																																							
8 bolts	<input checked="" type="checkbox"/>	2 Anchor Rods	<input checked="" type="checkbox"/>																																							
TRACK:	<table border="0" style="width:100%;"> <tr> <td><input type="checkbox"/></td><td>Regular</td> <td><input checked="" type="checkbox"/></td><td>6" web</td> <td><input type="checkbox"/></td><td>0.043" (1.09mm) 33ksi (230 Mpa)</td> </tr> <tr> <td><input checked="" type="checkbox"/></td><td>Extended</td> <td><input type="checkbox"/></td><td>3-5/8" web</td> <td><input type="checkbox"/></td><td>0.054" (1.37mm) 50ksi (345 Mpa)</td> </tr> <tr> <td><input type="checkbox"/></td><td>Reinforced</td> <td><input type="checkbox"/></td><td>1-1/4" flange</td> <td><input checked="" type="checkbox"/></td><td>0.068" (1.73mm) 50ksi (345 Mpa)</td> </tr> </table>							<input type="checkbox"/>	Regular	<input checked="" type="checkbox"/>	6" web	<input type="checkbox"/>	0.043" (1.09mm) 33ksi (230 Mpa)	<input checked="" type="checkbox"/>	Extended	<input type="checkbox"/>	3-5/8" web	<input type="checkbox"/>	0.054" (1.37mm) 50ksi (345 Mpa)	<input type="checkbox"/>	Reinforced	<input type="checkbox"/>	1-1/4" flange	<input checked="" type="checkbox"/>	0.068" (1.73mm) 50ksi (345 Mpa)																	
<input type="checkbox"/>	Regular	<input checked="" type="checkbox"/>	6" web	<input type="checkbox"/>	0.043" (1.09mm) 33ksi (230 Mpa)																																					
<input checked="" type="checkbox"/>	Extended	<input type="checkbox"/>	3-5/8" web	<input type="checkbox"/>	0.054" (1.37mm) 50ksi (345 Mpa)																																					
<input type="checkbox"/>	Reinforced	<input type="checkbox"/>	1-1/4" flange	<input checked="" type="checkbox"/>	0.068" (1.73mm) 50ksi (345 Mpa)																																					
HOLD DOWNS:	<table border="0" style="width:100%;"> <tr> <td><input type="checkbox"/></td><td>S/HD10S Simpson</td> <td rowspan="6" style="text-align: center;"> <table border="1" style="border-collapse: collapse;"> <tr><th>inside</th><th>outside</th><th>raised</th></tr> <tr><td><input type="checkbox"/></td><td><input type="checkbox"/></td><td><input type="checkbox"/></td></tr> <tr><td><input type="checkbox"/></td><td><input type="checkbox"/></td><td><input type="checkbox"/></td></tr> <tr><td><input type="checkbox"/></td><td><input type="checkbox"/></td><td><input type="checkbox"/></td></tr> <tr><td><input checked="" type="checkbox"/></td><td><input checked="" type="checkbox"/></td><td><input checked="" type="checkbox"/></td></tr> <tr><td><input type="checkbox"/></td><td><input type="checkbox"/></td><td><input type="checkbox"/></td></tr> </table> </td> </tr> <tr><td><input type="checkbox"/></td><td>Fabricated U-shape</td></tr> <tr><td><input type="checkbox"/></td><td>6" x 6" 0.054" (1.37mm) 50 ksi (340 MPa) Gusset Plate w/ S/HD15S Simpson</td></tr> <tr><td><input type="checkbox"/></td><td>7" x 9" 0.054" (1.37mm) 50 ksi (340 MPa) Gusset Plate w/ S/HD15S Simpson</td></tr> <tr><td><input type="checkbox"/></td><td>8" x 8" 0.068" (1.73mm) 50 ksi (340 MPa) Gusset Plate w/ S/HD15S Simpson</td></tr> <tr><td><input checked="" type="checkbox"/></td><td>8.5" x 10" 0.068" (1.73mm) 50 ksi (340 MPa) Gusset Plate w/ S/HD15S Simpson</td></tr> <tr><td><input type="checkbox"/></td><td>10" x 10" 0.054" (1.37mm) 50 ksi (340 MPa) Gusset Plate w/ S/HD15S Simpson</td></tr> </table>							<input type="checkbox"/>	S/HD10S Simpson	<table border="1" style="border-collapse: collapse;"> <tr><th>inside</th><th>outside</th><th>raised</th></tr> <tr><td><input type="checkbox"/></td><td><input type="checkbox"/></td><td><input type="checkbox"/></td></tr> <tr><td><input type="checkbox"/></td><td><input type="checkbox"/></td><td><input type="checkbox"/></td></tr> <tr><td><input type="checkbox"/></td><td><input type="checkbox"/></td><td><input type="checkbox"/></td></tr> <tr><td><input checked="" type="checkbox"/></td><td><input checked="" type="checkbox"/></td><td><input checked="" type="checkbox"/></td></tr> <tr><td><input type="checkbox"/></td><td><input type="checkbox"/></td><td><input type="checkbox"/></td></tr> </table>	inside	outside	raised	<input type="checkbox"/>	<input type="checkbox"/>	<input type="checkbox"/>	<input type="checkbox"/>	<input type="checkbox"/>	<input type="checkbox"/>	<input type="checkbox"/>	<input type="checkbox"/>	<input type="checkbox"/>	<input checked="" type="checkbox"/>	<input checked="" type="checkbox"/>	<input checked="" type="checkbox"/>	<input type="checkbox"/>	<input type="checkbox"/>	<input type="checkbox"/>	<input type="checkbox"/>	Fabricated U-shape	<input type="checkbox"/>	6" x 6" 0.054" (1.37mm) 50 ksi (340 MPa) Gusset Plate w/ S/HD15S Simpson	<input type="checkbox"/>	7" x 9" 0.054" (1.37mm) 50 ksi (340 MPa) Gusset Plate w/ S/HD15S Simpson	<input type="checkbox"/>	8" x 8" 0.068" (1.73mm) 50 ksi (340 MPa) Gusset Plate w/ S/HD15S Simpson	<input checked="" type="checkbox"/>	8.5" x 10" 0.068" (1.73mm) 50 ksi (340 MPa) Gusset Plate w/ S/HD15S Simpson	<input type="checkbox"/>	10" x 10" 0.054" (1.37mm) 50 ksi (340 MPa) Gusset Plate w/ S/HD15S Simpson		
<input type="checkbox"/>	S/HD10S Simpson	<table border="1" style="border-collapse: collapse;"> <tr><th>inside</th><th>outside</th><th>raised</th></tr> <tr><td><input type="checkbox"/></td><td><input type="checkbox"/></td><td><input type="checkbox"/></td></tr> <tr><td><input type="checkbox"/></td><td><input type="checkbox"/></td><td><input type="checkbox"/></td></tr> <tr><td><input type="checkbox"/></td><td><input type="checkbox"/></td><td><input type="checkbox"/></td></tr> <tr><td><input checked="" type="checkbox"/></td><td><input checked="" type="checkbox"/></td><td><input checked="" type="checkbox"/></td></tr> <tr><td><input type="checkbox"/></td><td><input type="checkbox"/></td><td><input type="checkbox"/></td></tr> </table>	inside	outside	raised	<input type="checkbox"/>	<input type="checkbox"/>	<input type="checkbox"/>	<input type="checkbox"/>		<input type="checkbox"/>	<input type="checkbox"/>	<input type="checkbox"/>	<input type="checkbox"/>	<input type="checkbox"/>	<input checked="" type="checkbox"/>	<input checked="" type="checkbox"/>	<input checked="" type="checkbox"/>	<input type="checkbox"/>	<input type="checkbox"/>	<input type="checkbox"/>																					
inside	outside		raised																																							
<input type="checkbox"/>	<input type="checkbox"/>		<input type="checkbox"/>																																							
<input type="checkbox"/>	<input type="checkbox"/>		<input type="checkbox"/>																																							
<input type="checkbox"/>	<input type="checkbox"/>		<input type="checkbox"/>																																							
<input checked="" type="checkbox"/>	<input checked="" type="checkbox"/>		<input checked="" type="checkbox"/>																																							
<input type="checkbox"/>	<input type="checkbox"/>	<input type="checkbox"/>																																								
<input type="checkbox"/>	Fabricated U-shape																																									
<input type="checkbox"/>	6" x 6" 0.054" (1.37mm) 50 ksi (340 MPa) Gusset Plate w/ S/HD15S Simpson																																									
<input type="checkbox"/>	7" x 9" 0.054" (1.37mm) 50 ksi (340 MPa) Gusset Plate w/ S/HD15S Simpson																																									
<input type="checkbox"/>	8" x 8" 0.068" (1.73mm) 50 ksi (340 MPa) Gusset Plate w/ S/HD15S Simpson																																									
<input checked="" type="checkbox"/>	8.5" x 10" 0.068" (1.73mm) 50 ksi (340 MPa) Gusset Plate w/ S/HD15S Simpson																																									
<input type="checkbox"/>	10" x 10" 0.054" (1.37mm) 50 ksi (340 MPa) Gusset Plate w/ S/HD15S Simpson																																									
TEST PROTOCOL AND DESCRIPTION:	<input checked="" type="checkbox"/> Monotonic (Rate of Loading 2.5 mm/min) <input type="checkbox"/> Cyclic (CUREE cyclic protocol)																																									
LVDT MEASUREMENTS:	<table border="0" style="width:100%;"> <tr><td><input checked="" type="checkbox"/></td><td>Actuator LVDT</td><td><input checked="" type="checkbox"/></td><td>North Uplift</td></tr> <tr><td><input checked="" type="checkbox"/></td><td>North Slip</td><td><input checked="" type="checkbox"/></td><td>South Uplift</td></tr> <tr><td><input checked="" type="checkbox"/></td><td>South Slip</td><td><input checked="" type="checkbox"/></td><td>Top of Wall</td></tr> </table>							<input checked="" type="checkbox"/>	Actuator LVDT	<input checked="" type="checkbox"/>	North Uplift	<input checked="" type="checkbox"/>	North Slip	<input checked="" type="checkbox"/>	South Uplift	<input checked="" type="checkbox"/>	South Slip	<input checked="" type="checkbox"/>	Top of Wall																							
<input checked="" type="checkbox"/>	Actuator LVDT	<input checked="" type="checkbox"/>	North Uplift																																							
<input checked="" type="checkbox"/>	North Slip	<input checked="" type="checkbox"/>	South Uplift																																							
<input checked="" type="checkbox"/>	South Slip	<input checked="" type="checkbox"/>	Top of Wall																																							
TOTAL: <input type="text" value="6"/>																																										
STRAP WIDTH BEFORE TEST:	<table border="0" style="width:100%;"> <tr> <td style="text-align: center;">Front Right</td> <td style="text-align: center;">Front Left, mm</td> <td style="text-align: center;">Back Right, mm</td> <td style="text-align: center;">Back Left, mm</td> </tr> <tr> <td style="text-align: center;"><input type="text"/></td> <td style="text-align: center;"><input type="text" value="101.10"/></td> <td style="text-align: center;"><input type="text" value="102.65"/></td> <td style="text-align: center;"><input type="text"/></td> </tr> <tr> <td style="text-align: center;"><input type="text"/></td> <td style="text-align: center;"><input type="text" value="101.31"/></td> <td style="text-align: center;"><input type="text" value="102.37"/></td> <td style="text-align: center;"><input type="text"/></td> </tr> <tr> <td style="text-align: center;"><input type="text"/></td> <td style="text-align: center;"><input type="text" value="101.33"/></td> <td style="text-align: center;"><input type="text" value="102.43"/></td> <td style="text-align: center;"><input type="text"/></td> </tr> <tr> <td style="text-align: center;">AVG</td> <td style="text-align: center;"><input type="text" value="0.00"/></td> <td style="text-align: center;">AVG</td> <td style="text-align: center;"><input type="text" value="101.25 mm"/></td> </tr> <tr> <td></td> <td></td> <td style="text-align: center;">AVG</td> <td style="text-align: center;"><input type="text" value="102.48 mm"/></td> </tr> <tr> <td></td> <td></td> <td></td> <td style="text-align: center;">AVG</td> <td style="text-align: center;"><input type="text" value="0.00 mm"/></td> </tr> </table>							Front Right	Front Left, mm	Back Right, mm	Back Left, mm	<input type="text"/>	<input type="text" value="101.10"/>	<input type="text" value="102.65"/>	<input type="text"/>	<input type="text"/>	<input type="text" value="101.31"/>	<input type="text" value="102.37"/>	<input type="text"/>	<input type="text"/>	<input type="text" value="101.33"/>	<input type="text" value="102.43"/>	<input type="text"/>	AVG	<input type="text" value="0.00"/>	AVG	<input type="text" value="101.25 mm"/>			AVG	<input type="text" value="102.48 mm"/>				AVG	<input type="text" value="0.00 mm"/>						
Front Right	Front Left, mm	Back Right, mm	Back Left, mm																																							
<input type="text"/>	<input type="text" value="101.10"/>	<input type="text" value="102.65"/>	<input type="text"/>																																							
<input type="text"/>	<input type="text" value="101.31"/>	<input type="text" value="102.37"/>	<input type="text"/>																																							
<input type="text"/>	<input type="text" value="101.33"/>	<input type="text" value="102.43"/>	<input type="text"/>																																							
AVG	<input type="text" value="0.00"/>	AVG	<input type="text" value="101.25 mm"/>																																							
		AVG	<input type="text" value="102.48 mm"/>																																							
			AVG	<input type="text" value="0.00 mm"/>																																						
DATA ACQ. RECORD RATE:	1 scan/sec		MONITOR RATE:	10 scan/sec																																						
COMMENTS:	<ul style="list-style-type: none"> -Shear anchors torqued for 10 s with impact wrench -Hold down anchors 1/2 turn from finger tight (load cells used on both hold-downs) -Ambient temperature 28 C -Double chord studs used screwed back to back -Square plate washers (2.5"x2.5") used in all top track connections -Regular washers used in all bottom track connections 																																									

Figure C. 14 Data sheet for test 37 A-M

Cold Formed Steel Strap Braced Walls McGill University, Montreal																																										
TEST:	38 A-C																																									
RESEARCHER:	Kostadin Velchev	ASSISTANTS:	Gilles Comeau, Nisreen Balh																																							
DATE:	30-Jul-07		TIME:	17:20																																						
DIMENSIONS OF WALL:	8 FT X	8 FT X	6 IN.	INITIAL STRAP SURVEY:	Front Back	Right tight loose	Left loose tight																																			
STRAP FASTENER CONFIGURATION:				MFR:	McGill																																					
STRAP SIZE:	<table border="0" style="width:100%;"> <tr><td><input type="checkbox"/></td><td>2.5" 0.043" (1.09mm) 33 ksi (230 MPa)</td></tr> <tr><td><input type="checkbox"/></td><td>2.75" 0.054" (1.37mm) 50 ksi (340 MPa)</td></tr> <tr><td><input checked="" type="checkbox"/></td><td>4" 0.068" (1.73mm) 50 ksi (340 MPa)</td></tr> <tr><td><input type="checkbox"/></td><td>5" 0.043" (1.09) 33 ksi (230 MPa)</td></tr> <tr><td><input type="checkbox"/></td><td>Reduced section strap -- fuse = 2.5" wide x 30" long -- ends = 3.75" wide 0.043" (1.09mm) 33 ksi (230 MPa)</td></tr> <tr><td><input type="checkbox"/></td><td>Reduced section strap -- fuse = 2.75" wide x 30" long -- ends = 4.25" wide 0.054" (1.37mm) 50 ksi (340 MPa)</td></tr> <tr><td><input type="checkbox"/></td><td>Reduced section strap -- fuse = 4" wide x 30" long -- ends = 6" wide 0.068" (1.73mm) 50 ksi (340 MPa)</td></tr> <tr><td><input type="checkbox"/></td><td>Reduced section strap -- fuse = 2.5" wide x 60" long -- ends = 3.75" wide 0.043" (1.09mm) 33 ksi (230 MPa)</td></tr> <tr><td><input type="checkbox"/></td><td>Reduced section strap -- fuse = 4" wide x 60" long -- ends = 6" wide 0.068" (1.73mm) 50 ksi (340 MPa)</td></tr> </table>							<input type="checkbox"/>	2.5" 0.043" (1.09mm) 33 ksi (230 MPa)	<input type="checkbox"/>	2.75" 0.054" (1.37mm) 50 ksi (340 MPa)	<input checked="" type="checkbox"/>	4" 0.068" (1.73mm) 50 ksi (340 MPa)	<input type="checkbox"/>	5" 0.043" (1.09) 33 ksi (230 MPa)	<input type="checkbox"/>	Reduced section strap -- fuse = 2.5" wide x 30" long -- ends = 3.75" wide 0.043" (1.09mm) 33 ksi (230 MPa)	<input type="checkbox"/>	Reduced section strap -- fuse = 2.75" wide x 30" long -- ends = 4.25" wide 0.054" (1.37mm) 50 ksi (340 MPa)	<input type="checkbox"/>	Reduced section strap -- fuse = 4" wide x 30" long -- ends = 6" wide 0.068" (1.73mm) 50 ksi (340 MPa)	<input type="checkbox"/>	Reduced section strap -- fuse = 2.5" wide x 60" long -- ends = 3.75" wide 0.043" (1.09mm) 33 ksi (230 MPa)	<input type="checkbox"/>	Reduced section strap -- fuse = 4" wide x 60" long -- ends = 6" wide 0.068" (1.73mm) 50 ksi (340 MPa)																	
<input type="checkbox"/>	2.5" 0.043" (1.09mm) 33 ksi (230 MPa)																																									
<input type="checkbox"/>	2.75" 0.054" (1.37mm) 50 ksi (340 MPa)																																									
<input checked="" type="checkbox"/>	4" 0.068" (1.73mm) 50 ksi (340 MPa)																																									
<input type="checkbox"/>	5" 0.043" (1.09) 33 ksi (230 MPa)																																									
<input type="checkbox"/>	Reduced section strap -- fuse = 2.5" wide x 30" long -- ends = 3.75" wide 0.043" (1.09mm) 33 ksi (230 MPa)																																									
<input type="checkbox"/>	Reduced section strap -- fuse = 2.75" wide x 30" long -- ends = 4.25" wide 0.054" (1.37mm) 50 ksi (340 MPa)																																									
<input type="checkbox"/>	Reduced section strap -- fuse = 4" wide x 30" long -- ends = 6" wide 0.068" (1.73mm) 50 ksi (340 MPa)																																									
<input type="checkbox"/>	Reduced section strap -- fuse = 2.5" wide x 60" long -- ends = 3.75" wide 0.043" (1.09mm) 33 ksi (230 MPa)																																									
<input type="checkbox"/>	Reduced section strap -- fuse = 4" wide x 60" long -- ends = 6" wide 0.068" (1.73mm) 50 ksi (340 MPa)																																									
INTERIOR STUDS:	<table border="0" style="width:100%;"> <tr><td><input type="checkbox"/></td><td>3-5/8"Wx1-5/8"Fx1/2"Lip 0.043" (1.09mm) 33ksi (230 Mpa)</td></tr> <tr><td><input checked="" type="checkbox"/></td><td>6"Wx1-5/8"Fx1/2"Lip 0.043" (1.09mm) 33ksi (230 Mpa)</td></tr> </table>		<input type="checkbox"/>	3-5/8"Wx1-5/8"Fx1/2"Lip 0.043" (1.09mm) 33ksi (230 Mpa)	<input checked="" type="checkbox"/>	6"Wx1-5/8"Fx1/2"Lip 0.043" (1.09mm) 33ksi (230 Mpa)	STUD SPACING:	<table border="0" style="width:100%;"> <tr><td><input checked="" type="checkbox"/></td><td>16" O.C.</td></tr> <tr><td><input type="checkbox"/></td><td>Other : _____</td></tr> </table>			<input checked="" type="checkbox"/>	16" O.C.	<input type="checkbox"/>	Other : _____																												
<input type="checkbox"/>	3-5/8"Wx1-5/8"Fx1/2"Lip 0.043" (1.09mm) 33ksi (230 Mpa)																																									
<input checked="" type="checkbox"/>	6"Wx1-5/8"Fx1/2"Lip 0.043" (1.09mm) 33ksi (230 Mpa)																																									
<input checked="" type="checkbox"/>	16" O.C.																																									
<input type="checkbox"/>	Other : _____																																									
BACK-TO-BACK CHORD STUDS:	<table border="0" style="width:100%;"> <tr><td><input type="checkbox"/></td><td>3-5/8"Wx1-5/8"Fx1/2"Lip 0.043" (1.09mm) 33ksi (230 Mpa)</td></tr> <tr><td><input type="checkbox"/></td><td>6"Wx1-5/8"Fx1/2"Lip 0.054" (1.37mm) 50ksi (345 Mpa)</td></tr> <tr><td><input checked="" type="checkbox"/></td><td>6"Wx1-5/8"Fx1/2"Lip 0.068" (1.73mm) 50ksi (345 Mpa)</td></tr> </table>							<input type="checkbox"/>	3-5/8"Wx1-5/8"Fx1/2"Lip 0.043" (1.09mm) 33ksi (230 Mpa)	<input type="checkbox"/>	6"Wx1-5/8"Fx1/2"Lip 0.054" (1.37mm) 50ksi (345 Mpa)	<input checked="" type="checkbox"/>	6"Wx1-5/8"Fx1/2"Lip 0.068" (1.73mm) 50ksi (345 Mpa)																													
<input type="checkbox"/>	3-5/8"Wx1-5/8"Fx1/2"Lip 0.043" (1.09mm) 33ksi (230 Mpa)																																									
<input type="checkbox"/>	6"Wx1-5/8"Fx1/2"Lip 0.054" (1.37mm) 50ksi (345 Mpa)																																									
<input checked="" type="checkbox"/>	6"Wx1-5/8"Fx1/2"Lip 0.068" (1.73mm) 50ksi (345 Mpa)																																									
CONNECTIONS:	<table border="0" style="width:100%;"> <tr><td>Straps:</td><td><input checked="" type="checkbox"/></td><td>No.10 gauge 0.75" self-drilling wafer head (mod. Truss) Phillips drive</td></tr> <tr><td>Framing:</td><td><input checked="" type="checkbox"/></td><td>No.8 gauge 0.5" self-drilling wafer head (mod. Truss) Phillips drive</td></tr> <tr><td>Hold downs:</td><td><input checked="" type="checkbox"/></td><td>No.14 gauge 1" self-drilling Hex washer head</td></tr> <tr><td>Back-to-Back:</td><td><input checked="" type="checkbox"/></td><td>No.14 gauge 1" self-drilling Hex washer head</td></tr> <tr><td>Chord Studs:</td><td><input checked="" type="checkbox"/></td><td>No.10 gauge 0.75" self-drilling Hex washer head</td></tr> <tr><td>Anchor Rods:</td><td><input type="checkbox"/></td><td>7/8" A307</td></tr> <tr><td></td><td><input checked="" type="checkbox"/></td><td>1" Rod</td></tr> <tr><td>Loading Beam:</td><td><input checked="" type="checkbox"/></td><td>A325 3/4" bolts</td></tr> <tr><td>Base:</td><td><input checked="" type="checkbox"/></td><td>A325 3/4" bolts</td></tr> </table>							Straps:	<input checked="" type="checkbox"/>	No.10 gauge 0.75" self-drilling wafer head (mod. Truss) Phillips drive	Framing:	<input checked="" type="checkbox"/>	No.8 gauge 0.5" self-drilling wafer head (mod. Truss) Phillips drive	Hold downs:	<input checked="" type="checkbox"/>	No.14 gauge 1" self-drilling Hex washer head	Back-to-Back:	<input checked="" type="checkbox"/>	No.14 gauge 1" self-drilling Hex washer head	Chord Studs:	<input checked="" type="checkbox"/>	No.10 gauge 0.75" self-drilling Hex washer head	Anchor Rods:	<input type="checkbox"/>	7/8" A307		<input checked="" type="checkbox"/>	1" Rod	Loading Beam:	<input checked="" type="checkbox"/>	A325 3/4" bolts	Base:	<input checked="" type="checkbox"/>	A325 3/4" bolts								
Straps:	<input checked="" type="checkbox"/>	No.10 gauge 0.75" self-drilling wafer head (mod. Truss) Phillips drive																																								
Framing:	<input checked="" type="checkbox"/>	No.8 gauge 0.5" self-drilling wafer head (mod. Truss) Phillips drive																																								
Hold downs:	<input checked="" type="checkbox"/>	No.14 gauge 1" self-drilling Hex washer head																																								
Back-to-Back:	<input checked="" type="checkbox"/>	No.14 gauge 1" self-drilling Hex washer head																																								
Chord Studs:	<input checked="" type="checkbox"/>	No.10 gauge 0.75" self-drilling Hex washer head																																								
Anchor Rods:	<input type="checkbox"/>	7/8" A307																																								
	<input checked="" type="checkbox"/>	1" Rod																																								
Loading Beam:	<input checked="" type="checkbox"/>	A325 3/4" bolts																																								
Base:	<input checked="" type="checkbox"/>	A325 3/4" bolts																																								
TRACK:	<table border="0" style="width:100%;"> <tr><td><input type="checkbox"/></td><td>Regular</td><td><input checked="" type="checkbox"/></td><td>6" web</td><td><input type="checkbox"/></td><td>0.043" (1.09mm) 33ksi (230 Mpa)</td></tr> <tr><td><input checked="" type="checkbox"/></td><td>Extended</td><td><input type="checkbox"/></td><td>3-5/8" web</td><td><input type="checkbox"/></td><td>0.054" (1.37mm) 50ksi (345 Mpa)</td></tr> <tr><td><input type="checkbox"/></td><td>Reinforced</td><td><input type="checkbox"/></td><td>1-1/4" flange</td><td><input checked="" type="checkbox"/></td><td>0.068" (1.73mm) 50ksi (345 Mpa)</td></tr> </table>							<input type="checkbox"/>	Regular	<input checked="" type="checkbox"/>	6" web	<input type="checkbox"/>	0.043" (1.09mm) 33ksi (230 Mpa)	<input checked="" type="checkbox"/>	Extended	<input type="checkbox"/>	3-5/8" web	<input type="checkbox"/>	0.054" (1.37mm) 50ksi (345 Mpa)	<input type="checkbox"/>	Reinforced	<input type="checkbox"/>	1-1/4" flange	<input checked="" type="checkbox"/>	0.068" (1.73mm) 50ksi (345 Mpa)																	
<input type="checkbox"/>	Regular	<input checked="" type="checkbox"/>	6" web	<input type="checkbox"/>	0.043" (1.09mm) 33ksi (230 Mpa)																																					
<input checked="" type="checkbox"/>	Extended	<input type="checkbox"/>	3-5/8" web	<input type="checkbox"/>	0.054" (1.37mm) 50ksi (345 Mpa)																																					
<input type="checkbox"/>	Reinforced	<input type="checkbox"/>	1-1/4" flange	<input checked="" type="checkbox"/>	0.068" (1.73mm) 50ksi (345 Mpa)																																					
HOLD DOWNS:	<table border="0" style="width:100%;"> <tr><td><input type="checkbox"/></td><td>S/HD10S Simpson</td><td colspan="3" style="text-align: center;">inside outside raised</td></tr> <tr><td><input type="checkbox"/></td><td>Fabricated U-shape</td><td><input type="checkbox"/></td><td><input type="checkbox"/></td><td><input type="checkbox"/></td></tr> <tr><td><input type="checkbox"/></td><td>6" x 6" 0.054" (1.37mm) 50 ksi (340 MPa) Gusset Plate w/ S/HD15S Simpson</td><td><input type="checkbox"/></td><td><input type="checkbox"/></td><td><input type="checkbox"/></td></tr> <tr><td><input type="checkbox"/></td><td>7" x 9" 0.054" (1.37mm) 50 ksi (340 MPa) Gusset Plate w/ S/HD15S Simpson</td><td><input type="checkbox"/></td><td><input type="checkbox"/></td><td><input type="checkbox"/></td></tr> <tr><td><input type="checkbox"/></td><td>8" x 8" 0.068" (1.73mm) 50 ksi (340 MPa) Gusset Plate w/ S/HD15S Simpson</td><td><input type="checkbox"/></td><td><input type="checkbox"/></td><td><input type="checkbox"/></td></tr> <tr><td><input checked="" type="checkbox"/></td><td>8.5" x 10" 0.068" (1.73mm) 50 ksi (340 MPa) Gusset Plate w/ S/HD15S Simpson</td><td><input type="checkbox"/></td><td><input checked="" type="checkbox"/></td><td><input checked="" type="checkbox"/></td></tr> <tr><td><input type="checkbox"/></td><td>10" x 10" 0.054" (1.37mm) 50 ksi (340 MPa) Gusset Plate w/ S/HD15S Simpson</td><td><input type="checkbox"/></td><td><input type="checkbox"/></td><td><input type="checkbox"/></td></tr> </table>							<input type="checkbox"/>	S/HD10S Simpson	inside outside raised			<input type="checkbox"/>	Fabricated U-shape	<input type="checkbox"/>	<input type="checkbox"/>	<input type="checkbox"/>	<input type="checkbox"/>	6" x 6" 0.054" (1.37mm) 50 ksi (340 MPa) Gusset Plate w/ S/HD15S Simpson	<input type="checkbox"/>	<input type="checkbox"/>	<input type="checkbox"/>	<input type="checkbox"/>	7" x 9" 0.054" (1.37mm) 50 ksi (340 MPa) Gusset Plate w/ S/HD15S Simpson	<input type="checkbox"/>	<input type="checkbox"/>	<input type="checkbox"/>	<input type="checkbox"/>	8" x 8" 0.068" (1.73mm) 50 ksi (340 MPa) Gusset Plate w/ S/HD15S Simpson	<input type="checkbox"/>	<input type="checkbox"/>	<input type="checkbox"/>	<input checked="" type="checkbox"/>	8.5" x 10" 0.068" (1.73mm) 50 ksi (340 MPa) Gusset Plate w/ S/HD15S Simpson	<input type="checkbox"/>	<input checked="" type="checkbox"/>	<input checked="" type="checkbox"/>	<input type="checkbox"/>	10" x 10" 0.054" (1.37mm) 50 ksi (340 MPa) Gusset Plate w/ S/HD15S Simpson	<input type="checkbox"/>	<input type="checkbox"/>	<input type="checkbox"/>
<input type="checkbox"/>	S/HD10S Simpson	inside outside raised																																								
<input type="checkbox"/>	Fabricated U-shape	<input type="checkbox"/>	<input type="checkbox"/>	<input type="checkbox"/>																																						
<input type="checkbox"/>	6" x 6" 0.054" (1.37mm) 50 ksi (340 MPa) Gusset Plate w/ S/HD15S Simpson	<input type="checkbox"/>	<input type="checkbox"/>	<input type="checkbox"/>																																						
<input type="checkbox"/>	7" x 9" 0.054" (1.37mm) 50 ksi (340 MPa) Gusset Plate w/ S/HD15S Simpson	<input type="checkbox"/>	<input type="checkbox"/>	<input type="checkbox"/>																																						
<input type="checkbox"/>	8" x 8" 0.068" (1.73mm) 50 ksi (340 MPa) Gusset Plate w/ S/HD15S Simpson	<input type="checkbox"/>	<input type="checkbox"/>	<input type="checkbox"/>																																						
<input checked="" type="checkbox"/>	8.5" x 10" 0.068" (1.73mm) 50 ksi (340 MPa) Gusset Plate w/ S/HD15S Simpson	<input type="checkbox"/>	<input checked="" type="checkbox"/>	<input checked="" type="checkbox"/>																																						
<input type="checkbox"/>	10" x 10" 0.054" (1.37mm) 50 ksi (340 MPa) Gusset Plate w/ S/HD15S Simpson	<input type="checkbox"/>	<input type="checkbox"/>	<input type="checkbox"/>																																						
TEST PROTOCOL AND DESCRIPTION:	<table border="0" style="width:100%;"> <tr><td><input type="checkbox"/></td><td>Monotonic (Rate of Loading 2.5 mm/min)</td></tr> <tr><td><input checked="" type="checkbox"/></td><td>Cyclic (CUREE cyclic protocol)</td></tr> </table>							<input type="checkbox"/>	Monotonic (Rate of Loading 2.5 mm/min)	<input checked="" type="checkbox"/>	Cyclic (CUREE cyclic protocol)																															
<input type="checkbox"/>	Monotonic (Rate of Loading 2.5 mm/min)																																									
<input checked="" type="checkbox"/>	Cyclic (CUREE cyclic protocol)																																									
LVDT MEASUREMENTS:	<table border="0" style="width:100%;"> <tr><td><input checked="" type="checkbox"/></td><td>Actuator LVDT</td><td><input checked="" type="checkbox"/></td><td>North Uplift</td></tr> <tr><td><input checked="" type="checkbox"/></td><td>North Slip</td><td><input checked="" type="checkbox"/></td><td>South Uplift</td></tr> <tr><td><input checked="" type="checkbox"/></td><td>South Slip</td><td><input checked="" type="checkbox"/></td><td>Top of Wall</td></tr> </table>							<input checked="" type="checkbox"/>	Actuator LVDT	<input checked="" type="checkbox"/>	North Uplift	<input checked="" type="checkbox"/>	North Slip	<input checked="" type="checkbox"/>	South Uplift	<input checked="" type="checkbox"/>	South Slip	<input checked="" type="checkbox"/>	Top of Wall																							
<input checked="" type="checkbox"/>	Actuator LVDT	<input checked="" type="checkbox"/>	North Uplift																																							
<input checked="" type="checkbox"/>	North Slip	<input checked="" type="checkbox"/>	South Uplift																																							
<input checked="" type="checkbox"/>	South Slip	<input checked="" type="checkbox"/>	Top of Wall																																							
TOTAL:							6																																			
STRAP WIDTH BEFORE TEST:	<table border="0" style="width:100%;"> <tr><td style="text-align: center;">Front Right</td><td style="text-align: center;">Front Left, mm</td><td style="text-align: center;">Back Right, mm</td><td style="text-align: center;">Back Left, mm</td></tr> <tr><td style="text-align: center;">102.37</td><td style="text-align: center;">99.02</td><td style="text-align: center;">102.39</td><td style="text-align: center;">102.33</td></tr> <tr><td style="text-align: center;">102.28</td><td style="text-align: center;">99.28</td><td style="text-align: center;">102.31</td><td style="text-align: center;">102.25</td></tr> <tr><td style="text-align: center;">102.21</td><td style="text-align: center;">100.72</td><td style="text-align: center;">102.18</td><td style="text-align: center;">102.18</td></tr> <tr><td style="text-align: center;">AVG</td><td style="text-align: center;">102.29</td><td style="text-align: center;">AVG</td><td style="text-align: center;">102.29</td></tr> <tr><td></td><td style="text-align: center;">99.67 mm</td><td></td><td style="text-align: center;">102.25 mm</td></tr> </table>							Front Right	Front Left, mm	Back Right, mm	Back Left, mm	102.37	99.02	102.39	102.33	102.28	99.28	102.31	102.25	102.21	100.72	102.18	102.18	AVG	102.29	AVG	102.29		99.67 mm		102.25 mm											
Front Right	Front Left, mm	Back Right, mm	Back Left, mm																																							
102.37	99.02	102.39	102.33																																							
102.28	99.28	102.31	102.25																																							
102.21	100.72	102.18	102.18																																							
AVG	102.29	AVG	102.29																																							
	99.67 mm		102.25 mm																																							
DATA ACQ. RECORD RATE:	100 scan/sec			MONITOR RATE:	100 scan/sec																																					
COMMENTS:	<ul style="list-style-type: none"> -Shear anchors torqued for 10 s with impact wrench -Hold down anchors 1/2 turn from finger tight (load cells used on both hold-downs) -Ambient temperature 30 C -Double chord studs used screwed back to back -Square plate washers (2.5"x2.5") used in all top track connections -Regular washers used in all bottom track connections 																																									

Figure C. 15 Data sheet for test 38 A-C

Cold Formed Steel Strap Braced Walls
McGill University, Montreal

TEST: 39A-M

RESEARCHER: Kostadin Velchev **ASSISTANTS:** Gilles Comeau, Nisreen Balh

DATE: 22-May-07 **TIME:** 13:05

DIMENSIONS OF WALL: 8 FT X 8 FT X 6 IN. **INITIAL STRAP SURVEY:** Front Back Right loose tight Left tight loose

STRAP FASTENER CONFIGURATION: MFR: McGill

STRAP SIZE:

<input type="checkbox"/>	2.5" 0.043" (1.09mm) 33 ksi (230 MPa)
<input checked="" type="checkbox"/>	2.75" 0.054" (1.37mm) 50 ksi (340 MPa)
<input type="checkbox"/>	4" 0.068" (1.73mm) 50 ksi (340 MPa)
<input type="checkbox"/>	5" 0.043" (1.09) 33 ksi (230 MPa)
<input type="checkbox"/>	Reduced section strap -- fuse = 2.5" wide x 30" long -- ends = 3.75" wide 0.043" (1.09mm) 33 ksi (230 MPa)
<input type="checkbox"/>	Reduced section strap -- fuse = 2.75" wide x 30" long -- ends = 4.25" wide 0.054" (1.37mm) 50 ksi (340 MPa)
<input type="checkbox"/>	Reduced section strap -- fuse = 4" wide x 30" long -- ends = 6" wide 0.068" (1.73mm) 50 ksi (340 MPa)
<input type="checkbox"/>	Reduced section strap -- fuse = 2.5" wide x 60" long -- ends = 3.75" wide 0.043" (1.09mm) 33 ksi (230 MPa)
<input type="checkbox"/>	Reduced section strap -- fuse = 4" wide x 60" long -- ends = 6" wide 0.068" (1.73mm) 50 ksi (340 MPa)

INTERIOR STUDS:

<input type="checkbox"/>	3-5/8"Wx1-5/8"Fx1/2"Lip 0.043" (1.09mm) 33ksi (230 MPa)
<input checked="" type="checkbox"/>	6"Wx1-5/8"Fx1/2"Lip 0.043" (1.09mm) 33ksi (230 MPa)

STUD SPACING: 16" O.C. Other: _____

BACK-TO-BACK CHORD STUDS:

<input type="checkbox"/>	3-5/8"Wx1-5/8"Fx1/2"Lip 0.043" (1.09mm) 33ksi (230 MPa)
<input checked="" type="checkbox"/>	6"Wx1-5/8"Fx1/2"Lip 0.054" (1.37mm) 50ksi (345 MPa)
<input type="checkbox"/>	6"Wx1-5/8"Fx1/2"Lip 0.068" (1.73mm) 50ksi (345 MPa)

CONNECTIONS:

<input checked="" type="checkbox"/>	Straps	No.10 gauge 0.75" self-drilling wafer head (mod. Truss) Phillips drive
<input checked="" type="checkbox"/>	Framing:	No.8 gauge 0.5" self-drilling wafer head (mod. Truss) Phillips drive
<input checked="" type="checkbox"/>	Hold downs:	No.14 gauge 1" self-drilling Hex washer head
<input checked="" type="checkbox"/>	Back-to-Back	No.14 gauge 1" self-drilling Hex washer head
<input checked="" type="checkbox"/>	Chord Studs:	No.10 gauge 0.75" self-drilling wafer washer head
<input type="checkbox"/>	Anchor Rods:	7/8" A307
<input checked="" type="checkbox"/>	1" Rod	
<input checked="" type="checkbox"/>	Loading Beam:	A325 3/4" bolts
<input checked="" type="checkbox"/>	Base:	A325 3/4" bolts

10 bolts 2 Anchor Rods
6 bolts 2 Anchor Rods

TRACK:

<input type="checkbox"/>	Regular	<input checked="" type="checkbox"/> 6" web	<input type="checkbox"/>	0.043" (1.09mm) 33ksi (230 MPa)
<input type="checkbox"/>	Extended	3 5/8" web	<input checked="" type="checkbox"/>	0.054" (1.37mm) 50ksi (345 MPa)
<input checked="" type="checkbox"/>	Reinforced	1-1/4" flange	<input type="checkbox"/>	0.068" (1.73mm) 50ksi (345 MPa)

HOLD DOWNS:

<input type="checkbox"/>	S/HD10S Simpson	inside	outside	raised
<input type="checkbox"/>	Fabricated U-shape			
<input type="checkbox"/>	6" x 6" 0.054" (1.37mm) 50 ksi (340 MPa) Gusset Plate w/ S/HD15S Simpson			
<input checked="" type="checkbox"/>	7" x 9" 0.054" (1.37mm) 50 ksi (340 MPa) Gusset Plate w/ S/HD15S Simpson	<input checked="" type="checkbox"/>		
<input type="checkbox"/>	8" x 8" 0.068" (1.73mm) 50 ksi (340 MPa) Gusset Plate w/ S/HD15S Simpson			
<input type="checkbox"/>	8.5" x 10" 0.068" (1.73mm) 50 ksi (340 MPa) Gusset Plate w/ S/HD15S Simpson			
<input type="checkbox"/>	10" x 10" 0.054" (1.37mm) 50 ksi (340 MPa) Gusset Plate w/ S/HD15S Simpson			

TEST PROTOCOL AND DESCRIPTION:

<input checked="" type="checkbox"/>	Monotonic (Rate of Loading 2.5 mm/min)
<input type="checkbox"/>	Cyclic (CUREE cyclic protocol)

LVDT MEASUREMENTS:

<input checked="" type="checkbox"/>	Actuator LVDT	<input checked="" type="checkbox"/>	North Uplift
<input checked="" type="checkbox"/>	North Slip	<input checked="" type="checkbox"/>	South Uplift
<input checked="" type="checkbox"/>	South Slip	<input checked="" type="checkbox"/>	Top of Wall

TOTAL:

STRAP WIDTH BEFORE TEST:

Front Right, mm	Front Left, mm	Back Right, mm	Back Left, mm
<input type="text"/>	<input type="text" value="70.10"/>	<input type="text" value="70.20"/>	<input type="text"/>
<input type="text"/>	<input type="text" value="70.35"/>	<input type="text" value="70.27"/>	<input type="text"/>
<input type="text"/>	<input type="text" value="70.40"/>	<input type="text" value="70.58"/>	<input type="text"/>
AVG <input type="text" value="0.00"/> mm	AVG <input type="text" value="70.28"/> mm	AVG <input type="text" value="70.35"/> mm	AVG <input type="text" value="0.00"/> mm

DATA ACQ. RECORD RATE: 1 scan/sec **MONITOR RATE:** 10 scan/sec

COMMENTS:

- Shear anchors torqued for 10 s with impact wrench
- Hold down anchors 1/2 turn from finger tight (load cells used on both hold-downs)
- Ambient temperature 25 C
- Double chord studs used screwed back to back
- Square plate washers (2.5"x2.5") used in all top track connections
- Regular washers used in all bottom track connections

Figure C. 16 Data sheet for test 39 A-M

Cold Formed Steel Strap Braced Walls																																													
McGill University, Montreal																																													
TEST:	40 A-C																																												
RESEARCHER:	Kostadin Velchev	ASSISTANTS:	Gilles Comeau, Nisreen Balh																																										
DATE:	30-Jul-07		TIME:	9:31																																									
DIMENSIONS OF WALL:	8 FT X	8 FT X	6 IN.	INITIAL STRAP SURVEY:	Front	Right	Left																																						
					Back	tight	tight																																						
					loose	loose	loose																																						
STRAP FASTENER CONFIGURATION:	MFR: McGill																																												
STRAP SIZE:	<table border="1" style="width:100%; border-collapse: collapse;"> <tr><td><input type="checkbox"/></td><td>2.5" 0.043" (1.09mm) 33 ksi (230 MPa)</td></tr> <tr><td><input checked="" type="checkbox"/></td><td>2.75" 0.054" (1.37mm) 50 ksi (340 MPa)</td></tr> <tr><td><input type="checkbox"/></td><td>4" 0.068" (1.73mm) 50 ksi (340 MPa)</td></tr> <tr><td><input type="checkbox"/></td><td>5" 0.043" (1.09) 33 ksi (230 MPa)</td></tr> <tr><td><input type="checkbox"/></td><td>Reduced section strap -- fuse = 2.5" wide x 30" long -- ends = 3.75" wide 0.043" (1.09mm) 33 ksi (230 MPa)</td></tr> <tr><td><input type="checkbox"/></td><td>Reduced section strap -- fuse = 2.75" wide x 30" long -- ends = 4.25" wide 0.054" (1.37mm) 50 ksi (340 MPa)</td></tr> <tr><td><input type="checkbox"/></td><td>Reduced section strap -- fuse = 4" wide x 30" long -- ends = 6" wide 0.068" (1.73mm) 50 ksi (340 MPa)</td></tr> <tr><td><input type="checkbox"/></td><td>Reduced section strap -- fuse = 2.5" wide x 60" long -- ends = 3.75" wide 0.043" (1.09mm) 33 ksi (230 MPa)</td></tr> <tr><td><input type="checkbox"/></td><td>Reduced section strap -- fuse = 4" wide x 60" long -- ends = 6" wide 0.068" (1.73mm) 50 ksi (340 MPa)</td></tr> </table>			<input type="checkbox"/>	2.5" 0.043" (1.09mm) 33 ksi (230 MPa)	<input checked="" type="checkbox"/>	2.75" 0.054" (1.37mm) 50 ksi (340 MPa)	<input type="checkbox"/>	4" 0.068" (1.73mm) 50 ksi (340 MPa)	<input type="checkbox"/>	5" 0.043" (1.09) 33 ksi (230 MPa)	<input type="checkbox"/>	Reduced section strap -- fuse = 2.5" wide x 30" long -- ends = 3.75" wide 0.043" (1.09mm) 33 ksi (230 MPa)	<input type="checkbox"/>	Reduced section strap -- fuse = 2.75" wide x 30" long -- ends = 4.25" wide 0.054" (1.37mm) 50 ksi (340 MPa)	<input type="checkbox"/>	Reduced section strap -- fuse = 4" wide x 30" long -- ends = 6" wide 0.068" (1.73mm) 50 ksi (340 MPa)	<input type="checkbox"/>	Reduced section strap -- fuse = 2.5" wide x 60" long -- ends = 3.75" wide 0.043" (1.09mm) 33 ksi (230 MPa)	<input type="checkbox"/>	Reduced section strap -- fuse = 4" wide x 60" long -- ends = 6" wide 0.068" (1.73mm) 50 ksi (340 MPa)																								
<input type="checkbox"/>	2.5" 0.043" (1.09mm) 33 ksi (230 MPa)																																												
<input checked="" type="checkbox"/>	2.75" 0.054" (1.37mm) 50 ksi (340 MPa)																																												
<input type="checkbox"/>	4" 0.068" (1.73mm) 50 ksi (340 MPa)																																												
<input type="checkbox"/>	5" 0.043" (1.09) 33 ksi (230 MPa)																																												
<input type="checkbox"/>	Reduced section strap -- fuse = 2.5" wide x 30" long -- ends = 3.75" wide 0.043" (1.09mm) 33 ksi (230 MPa)																																												
<input type="checkbox"/>	Reduced section strap -- fuse = 2.75" wide x 30" long -- ends = 4.25" wide 0.054" (1.37mm) 50 ksi (340 MPa)																																												
<input type="checkbox"/>	Reduced section strap -- fuse = 4" wide x 30" long -- ends = 6" wide 0.068" (1.73mm) 50 ksi (340 MPa)																																												
<input type="checkbox"/>	Reduced section strap -- fuse = 2.5" wide x 60" long -- ends = 3.75" wide 0.043" (1.09mm) 33 ksi (230 MPa)																																												
<input type="checkbox"/>	Reduced section strap -- fuse = 4" wide x 60" long -- ends = 6" wide 0.068" (1.73mm) 50 ksi (340 MPa)																																												
INTERIOR STUDS:	<table border="1" style="width:100%; border-collapse: collapse;"> <tr><td><input type="checkbox"/></td><td>3-5/8"Wx1-5/8"Fx1/2"Lip 0.043" (1.09mm) 33ksi (230 MPa)</td></tr> <tr><td><input checked="" type="checkbox"/></td><td>6"Wx1-5/8"Fx1/2"Lip 0.043" (1.09mm) 33ksi (230 MPa)</td></tr> </table>		<input type="checkbox"/>	3-5/8"Wx1-5/8"Fx1/2"Lip 0.043" (1.09mm) 33ksi (230 MPa)	<input checked="" type="checkbox"/>	6"Wx1-5/8"Fx1/2"Lip 0.043" (1.09mm) 33ksi (230 MPa)	STUD SPACING:	<table border="1" style="width:100%; border-collapse: collapse;"> <tr><td><input checked="" type="checkbox"/></td><td>16" O.C.</td></tr> <tr><td><input type="checkbox"/></td><td>Other: _____</td></tr> </table>	<input checked="" type="checkbox"/>	16" O.C.	<input type="checkbox"/>	Other: _____																																	
<input type="checkbox"/>	3-5/8"Wx1-5/8"Fx1/2"Lip 0.043" (1.09mm) 33ksi (230 MPa)																																												
<input checked="" type="checkbox"/>	6"Wx1-5/8"Fx1/2"Lip 0.043" (1.09mm) 33ksi (230 MPa)																																												
<input checked="" type="checkbox"/>	16" O.C.																																												
<input type="checkbox"/>	Other: _____																																												
BACK-TO-BACK CHORD STUDS:	<table border="1" style="width:100%; border-collapse: collapse;"> <tr><td><input type="checkbox"/></td><td>3-5/8"Wx1-5/8"Fx1/2"Lip 0.043" (1.09mm) 33ksi (230 MPa)</td></tr> <tr><td><input checked="" type="checkbox"/></td><td>6"Wx1-5/8"Fx1/2"Lip 0.054" (1.37mm) 50ksi (345 MPa)</td></tr> <tr><td><input type="checkbox"/></td><td>6"Wx1-5/8"Fx1/2"Lip 0.068" (1.73mm) 50ksi (345 MPa)</td></tr> </table>			<input type="checkbox"/>	3-5/8"Wx1-5/8"Fx1/2"Lip 0.043" (1.09mm) 33ksi (230 MPa)	<input checked="" type="checkbox"/>	6"Wx1-5/8"Fx1/2"Lip 0.054" (1.37mm) 50ksi (345 MPa)	<input type="checkbox"/>	6"Wx1-5/8"Fx1/2"Lip 0.068" (1.73mm) 50ksi (345 MPa)																																				
<input type="checkbox"/>	3-5/8"Wx1-5/8"Fx1/2"Lip 0.043" (1.09mm) 33ksi (230 MPa)																																												
<input checked="" type="checkbox"/>	6"Wx1-5/8"Fx1/2"Lip 0.054" (1.37mm) 50ksi (345 MPa)																																												
<input type="checkbox"/>	6"Wx1-5/8"Fx1/2"Lip 0.068" (1.73mm) 50ksi (345 MPa)																																												
CONNECTIONS:	<table border="1" style="width:100%; border-collapse: collapse;"> <tr><td><input checked="" type="checkbox"/></td><td>Straps</td><td>No. 10 gauge 0.75" self-drilling wafer head (mod. Truss) Phillips drive</td></tr> <tr><td><input checked="" type="checkbox"/></td><td>Framing:</td><td>No. 8 gauge 0.5" self-drilling wafer head (mod. Truss) Phillips drive</td></tr> <tr><td><input type="checkbox"/></td><td>Hold downs:</td><td>No. 14 gauge 1" self-drilling Hex washer head</td></tr> <tr><td><input checked="" type="checkbox"/></td><td>Back-to-Back</td><td>No. 14 gauge 1" self-drilling Hex washer head</td></tr> <tr><td><input checked="" type="checkbox"/></td><td>Chord Studs:</td><td>No. 10 gauge 0.75" self-drilling wafer washer head</td></tr> <tr><td><input type="checkbox"/></td><td>Anchor Rods:</td><td>7/8" A307</td></tr> <tr><td><input checked="" type="checkbox"/></td><td>1" Rod</td><td></td></tr> <tr><td><input checked="" type="checkbox"/></td><td>Loading Beam:</td><td>A325 3/4" bolts</td></tr> <tr><td><input checked="" type="checkbox"/></td><td>Base:</td><td>A325 3/4" bolts</td></tr> </table>			<input checked="" type="checkbox"/>	Straps	No. 10 gauge 0.75" self-drilling wafer head (mod. Truss) Phillips drive	<input checked="" type="checkbox"/>	Framing:	No. 8 gauge 0.5" self-drilling wafer head (mod. Truss) Phillips drive	<input type="checkbox"/>	Hold downs:	No. 14 gauge 1" self-drilling Hex washer head	<input checked="" type="checkbox"/>	Back-to-Back	No. 14 gauge 1" self-drilling Hex washer head	<input checked="" type="checkbox"/>	Chord Studs:	No. 10 gauge 0.75" self-drilling wafer washer head	<input type="checkbox"/>	Anchor Rods:	7/8" A307	<input checked="" type="checkbox"/>	1" Rod		<input checked="" type="checkbox"/>	Loading Beam:	A325 3/4" bolts	<input checked="" type="checkbox"/>	Base:	A325 3/4" bolts															
<input checked="" type="checkbox"/>	Straps	No. 10 gauge 0.75" self-drilling wafer head (mod. Truss) Phillips drive																																											
<input checked="" type="checkbox"/>	Framing:	No. 8 gauge 0.5" self-drilling wafer head (mod. Truss) Phillips drive																																											
<input type="checkbox"/>	Hold downs:	No. 14 gauge 1" self-drilling Hex washer head																																											
<input checked="" type="checkbox"/>	Back-to-Back	No. 14 gauge 1" self-drilling Hex washer head																																											
<input checked="" type="checkbox"/>	Chord Studs:	No. 10 gauge 0.75" self-drilling wafer washer head																																											
<input type="checkbox"/>	Anchor Rods:	7/8" A307																																											
<input checked="" type="checkbox"/>	1" Rod																																												
<input checked="" type="checkbox"/>	Loading Beam:	A325 3/4" bolts																																											
<input checked="" type="checkbox"/>	Base:	A325 3/4" bolts																																											
	10 bolts	<input checked="" type="checkbox"/>	2 Anchor Rods	<input checked="" type="checkbox"/>																																									
	6 bolts	<input checked="" type="checkbox"/>	2 Anchor Rods	<input checked="" type="checkbox"/>																																									
TRACK:	<table border="1" style="width:100%; border-collapse: collapse;"> <tr><td><input type="checkbox"/></td><td>Regular</td><td><input checked="" type="checkbox"/></td><td>6" web</td><td><input type="checkbox"/></td><td>0.043" (1.09mm) 33ksi (230 MPa)</td></tr> <tr><td><input type="checkbox"/></td><td>Extended</td><td><input type="checkbox"/></td><td>3 5/8" web</td><td><input checked="" type="checkbox"/></td><td>0.054" (1.37mm) 50ksi (345 MPa)</td></tr> <tr><td><input checked="" type="checkbox"/></td><td>Reinforced</td><td><input type="checkbox"/></td><td>1-1/4" flange</td><td><input type="checkbox"/></td><td>0.068" (1.73mm) 50ksi (345 MPa)</td></tr> </table>			<input type="checkbox"/>	Regular	<input checked="" type="checkbox"/>	6" web	<input type="checkbox"/>	0.043" (1.09mm) 33ksi (230 MPa)	<input type="checkbox"/>	Extended	<input type="checkbox"/>	3 5/8" web	<input checked="" type="checkbox"/>	0.054" (1.37mm) 50ksi (345 MPa)	<input checked="" type="checkbox"/>	Reinforced	<input type="checkbox"/>	1-1/4" flange	<input type="checkbox"/>	0.068" (1.73mm) 50ksi (345 MPa)																								
<input type="checkbox"/>	Regular	<input checked="" type="checkbox"/>	6" web	<input type="checkbox"/>	0.043" (1.09mm) 33ksi (230 MPa)																																								
<input type="checkbox"/>	Extended	<input type="checkbox"/>	3 5/8" web	<input checked="" type="checkbox"/>	0.054" (1.37mm) 50ksi (345 MPa)																																								
<input checked="" type="checkbox"/>	Reinforced	<input type="checkbox"/>	1-1/4" flange	<input type="checkbox"/>	0.068" (1.73mm) 50ksi (345 MPa)																																								
HOLD DOWNS:	<table border="1" style="width:100%; border-collapse: collapse;"> <tr><td><input type="checkbox"/></td><td>S/HD10S Simpson</td><td></td><td></td><td></td><td></td></tr> <tr><td><input type="checkbox"/></td><td>Fabricated U-shape</td><td></td><td></td><td></td><td></td></tr> <tr><td><input type="checkbox"/></td><td>6" x 6" 0.054" (1.37mm) 50 ksi (340 MPa) Gusset Plate w/ S/HD15S Simpson</td><td></td><td></td><td></td><td></td></tr> <tr><td><input checked="" type="checkbox"/></td><td>7" x 9" 0.054" (1.37mm) 50 ksi (340 MPa) Gusset Plate w/ S/HD15S Simpson</td><td></td><td></td><td></td><td></td></tr> <tr><td><input type="checkbox"/></td><td>8" x 8" 0.068" (1.73mm) 50 ksi (340 MPa) Gusset Plate w/ S/HD15S Simpson</td><td></td><td></td><td></td><td></td></tr> <tr><td><input type="checkbox"/></td><td>8.5" x 10" 0.068" (1.73mm) 50 ksi (340 MPa) Gusset Plate w/ S/HD15S Simpson</td><td></td><td></td><td></td><td></td></tr> <tr><td><input type="checkbox"/></td><td>10" x 10" 0.054" (1.37mm) 50 ksi (340 MPa) Gusset Plate w/ S/HD15S Simpson</td><td></td><td></td><td></td><td></td></tr> </table>			<input type="checkbox"/>	S/HD10S Simpson					<input type="checkbox"/>	Fabricated U-shape					<input type="checkbox"/>	6" x 6" 0.054" (1.37mm) 50 ksi (340 MPa) Gusset Plate w/ S/HD15S Simpson					<input checked="" type="checkbox"/>	7" x 9" 0.054" (1.37mm) 50 ksi (340 MPa) Gusset Plate w/ S/HD15S Simpson					<input type="checkbox"/>	8" x 8" 0.068" (1.73mm) 50 ksi (340 MPa) Gusset Plate w/ S/HD15S Simpson					<input type="checkbox"/>	8.5" x 10" 0.068" (1.73mm) 50 ksi (340 MPa) Gusset Plate w/ S/HD15S Simpson					<input type="checkbox"/>	10" x 10" 0.054" (1.37mm) 50 ksi (340 MPa) Gusset Plate w/ S/HD15S Simpson				
<input type="checkbox"/>	S/HD10S Simpson																																												
<input type="checkbox"/>	Fabricated U-shape																																												
<input type="checkbox"/>	6" x 6" 0.054" (1.37mm) 50 ksi (340 MPa) Gusset Plate w/ S/HD15S Simpson																																												
<input checked="" type="checkbox"/>	7" x 9" 0.054" (1.37mm) 50 ksi (340 MPa) Gusset Plate w/ S/HD15S Simpson																																												
<input type="checkbox"/>	8" x 8" 0.068" (1.73mm) 50 ksi (340 MPa) Gusset Plate w/ S/HD15S Simpson																																												
<input type="checkbox"/>	8.5" x 10" 0.068" (1.73mm) 50 ksi (340 MPa) Gusset Plate w/ S/HD15S Simpson																																												
<input type="checkbox"/>	10" x 10" 0.054" (1.37mm) 50 ksi (340 MPa) Gusset Plate w/ S/HD15S Simpson																																												
TEST PROTOCOL AND DESCRIPTION:	<table border="1" style="width:100%; border-collapse: collapse;"> <tr><td><input type="checkbox"/></td><td>Monotonic (Rate of Loading 2.5 mm/min)</td></tr> <tr><td><input checked="" type="checkbox"/></td><td>Cyclic (CUREE cyclic protocol)</td></tr> </table>			<input type="checkbox"/>	Monotonic (Rate of Loading 2.5 mm/min)	<input checked="" type="checkbox"/>	Cyclic (CUREE cyclic protocol)																																						
<input type="checkbox"/>	Monotonic (Rate of Loading 2.5 mm/min)																																												
<input checked="" type="checkbox"/>	Cyclic (CUREE cyclic protocol)																																												
LVDT MEASUREMENTS:	<table border="1" style="width:100%; border-collapse: collapse;"> <tr><td><input checked="" type="checkbox"/></td><td>Actuator LVDT</td><td><input checked="" type="checkbox"/></td><td>North Uplift</td></tr> <tr><td><input checked="" type="checkbox"/></td><td>North Slip</td><td><input checked="" type="checkbox"/></td><td>South Uplift</td></tr> <tr><td><input checked="" type="checkbox"/></td><td>South Slip</td><td><input checked="" type="checkbox"/></td><td>Top of Wall</td></tr> </table>			<input checked="" type="checkbox"/>	Actuator LVDT	<input checked="" type="checkbox"/>	North Uplift	<input checked="" type="checkbox"/>	North Slip	<input checked="" type="checkbox"/>	South Uplift	<input checked="" type="checkbox"/>	South Slip	<input checked="" type="checkbox"/>	Top of Wall																														
<input checked="" type="checkbox"/>	Actuator LVDT	<input checked="" type="checkbox"/>	North Uplift																																										
<input checked="" type="checkbox"/>	North Slip	<input checked="" type="checkbox"/>	South Uplift																																										
<input checked="" type="checkbox"/>	South Slip	<input checked="" type="checkbox"/>	Top of Wall																																										
	TOTAL: <input type="text" value="6"/>																																												
STRAP WIDTH BEFORE TEST:	<table border="1" style="width:100%; border-collapse: collapse;"> <tr> <td style="text-align: center;">Front Right, mm</td> <td style="text-align: center;">Front Left, mm</td> <td style="text-align: center;">Back Right, mm</td> <td style="text-align: center;">Back Left, mm</td> </tr> <tr> <td style="text-align: center;">70.45</td> <td style="text-align: center;">70.44</td> <td style="text-align: center;">70.20</td> <td style="text-align: center;">69.68</td> </tr> <tr> <td style="text-align: center;">70.32</td> <td style="text-align: center;">70.28</td> <td style="text-align: center;">69.73</td> <td style="text-align: center;">70.21</td> </tr> <tr> <td style="text-align: center;">70.33</td> <td style="text-align: center;">70.29</td> <td style="text-align: center;">70.80</td> <td style="text-align: center;">70.12</td> </tr> <tr> <td style="text-align: center;">AVG 70.37 mm</td> <td style="text-align: center;">AVG 70.34 mm</td> <td style="text-align: center;">AVG 70.24 mm</td> <td style="text-align: center;">AVG 70.00 mm</td> </tr> </table>			Front Right, mm	Front Left, mm	Back Right, mm	Back Left, mm	70.45	70.44	70.20	69.68	70.32	70.28	69.73	70.21	70.33	70.29	70.80	70.12	AVG 70.37 mm	AVG 70.34 mm	AVG 70.24 mm	AVG 70.00 mm																						
Front Right, mm	Front Left, mm	Back Right, mm	Back Left, mm																																										
70.45	70.44	70.20	69.68																																										
70.32	70.28	69.73	70.21																																										
70.33	70.29	70.80	70.12																																										
AVG 70.37 mm	AVG 70.34 mm	AVG 70.24 mm	AVG 70.00 mm																																										
DATA ACQ. RECORD RATE:	100 scan/sec		MONITOR RATE:	100 scan/sec																																									
COMMENTS:	<ul style="list-style-type: none"> -Shear anchors torqued for 10 s with impact wrench -Hold down anchors 1/2 turn from finger tight (load cells used on both hold-downs) -Ambient temperature 28 C -Double chord studs used screwed back to back -Square plate washers (2.5"x2.5") used in all top track connections -Regular washers used in all bottom track connections 																																												

Figure C. 17 Data sheet for test 40 A-C

Cold Formed Steel Strap Braced Walls
McGill University, Montreal

TEST: 41 A-M

RESEARCHER: Kostadin Velchev **ASSISTANTS:** Gilles Comeau, Nisreen Balh

DATE: 8-Aug-07 **TIME:** 16:48

DIMENSIONS OF WALL: 8 FT X 8 FT X 3-5/8 IN. **INITIAL STRAP SURVEY:** Front Back Right Left loose loose

STRAP FASTENER CONFIGURATION: MFR: McGill

STRAP SIZE:

<input checked="" type="checkbox"/>	2.5" 0.043" (1.09mm) 33 ksi (230 MPa)
<input type="checkbox"/>	2.75" 0.054" (1.37mm) 50 ksi (340 MPa)
<input type="checkbox"/>	4" 0.068" (1.73mm) 50 ksi (340 MPa)
<input type="checkbox"/>	5" 0.043" (1.09) 33 ksi (230 MPa)
<input type="checkbox"/>	Reduced section strap -- fuse = 2.5" wide x 30" long -- ends = 3.75" wide 0.043" (1.09mm) 33 ksi (230 MPa)
<input type="checkbox"/>	Reduced section strap -- fuse = 2.75" wide x 30" long -- ends = 4.25" wide 0.054" (1.37mm) 50 ksi (340 MPa)
<input type="checkbox"/>	Reduced section strap -- fuse = 4" wide x 30" long -- ends = 6" wide 0.068" (1.73mm) 50 ksi (340 MPa)
<input type="checkbox"/>	Reduced section strap -- fuse = 2.5" wide x 60" long -- ends = 3.75" wide 0.043" (1.09mm) 33 ksi (230 MPa)
<input type="checkbox"/>	Reduced section strap -- fuse = 4" wide x 60" long -- ends = 6" wide 0.068" (1.73mm) 50 ksi (340 MPa)

INTERIOR STUDS:

<input checked="" type="checkbox"/>	3-5/8"Wx1-5/8"Fx1/2"Lip 0.043" (1.09mm) 33ksi (230 Mpa)
<input type="checkbox"/>	6"Wx1-5/8"Fx1/2"Lip 0.043" (1.09mm) 33ksi (230 Mpa)

STUD SPACING:

<input checked="" type="checkbox"/>	16" O.C.
<input type="checkbox"/>	Other : _____

BACK-TO-BACK CHORD STUDS:

<input checked="" type="checkbox"/>	3-5/8"Wx1-5/8"Fx1/2"Lip 0.043" (1.09mm) 33ksi (230 Mpa)
<input type="checkbox"/>	6"Wx1-5/8"Fx1/2"Lip 0.054" (1.37mm) 50ksi (345 Mpa)
<input type="checkbox"/>	6"Wx1-5/8"Fx1/2"Lip 0.068" (1.73mm) 50ksi (345 Mpa)

CONNECTIONS:

Straps	<input checked="" type="checkbox"/>	No.10 gauge 0.75" self-drilling wafer head (mod. Truss) Phillips drive
Framing	<input checked="" type="checkbox"/>	No.8 gauge 0.5" self-drilling wafer head (mod. Truss) Phillips drive
Hold downs	<input type="checkbox"/>	
Back-to-Back	<input type="checkbox"/>	
Chord Studs	<input checked="" type="checkbox"/>	No.10 gauge 0.75" self-drilling Hex washer head
Anchor Rods	<input type="checkbox"/>	7/8" A307
	<input checked="" type="checkbox"/>	1" Rod
Loading Beam	<input checked="" type="checkbox"/>	A325 3/4" bolts
Base	<input checked="" type="checkbox"/>	A325 3/4" bolts

10 bolts	<input checked="" type="checkbox"/>
6 bolts	<input checked="" type="checkbox"/>

2 Anchor Rods	<input checked="" type="checkbox"/>
2 Anchor Rods	<input checked="" type="checkbox"/>

TRACK:

<input checked="" type="checkbox"/>	Regular	<input type="checkbox"/>	6" web	<input checked="" type="checkbox"/>	0.043" (1.09mm) 33ksi (230 Mpa)
<input type="checkbox"/>	Extended	<input checked="" type="checkbox"/>	3 5/8" web	<input type="checkbox"/>	0.054" (1.37mm) 50ksi (345 Mpa)
<input type="checkbox"/>	Reinforced	<input type="checkbox"/>	1-1/4" flange	<input type="checkbox"/>	0.068" (1.73mm) 50ksi (345 Mpa)

HOLD DOWNS:

<input checked="" type="checkbox"/>	S/HD10S Simpson
<input checked="" type="checkbox"/>	Fabricated U-shape
<input type="checkbox"/>	6" x 6" 0.054" (1.37mm) 50 ksi (340 MPa) Gusset Plate w/ S/HD15S Simpson
<input type="checkbox"/>	7" x 9" 0.054" (1.37mm) 50 ksi (340 MPa) Gusset Plate w/ S/HD15S Simpson
<input type="checkbox"/>	8" x 8" 0.068" (1.73mm) 50 ksi (340 MPa) Gusset Plate w/ S/HD15S Simpson
<input type="checkbox"/>	8.5" x 10" 0.068" (1.73mm) 50 ksi (340 MPa) Gusset Plate w/ S/HD15S Simpson
<input type="checkbox"/>	10" x 10" 0.054" (1.37mm) 50 ksi (340 MPa) Gusset Plate w/ S/HD15S Simpson

inside	outside	raised

TEST PROTOCOL AND DESCRIPTION:

<input checked="" type="checkbox"/>	Monotonic (Rate of Loading 2.5 mm/min)
<input type="checkbox"/>	Cyclic (CUREE cyclic protocol)

LVDT MEASUREMENTS:

<input checked="" type="checkbox"/>	Actuator LVDT	<input checked="" type="checkbox"/>	North Uplift
<input checked="" type="checkbox"/>	North Slip	<input checked="" type="checkbox"/>	South Uplift
<input checked="" type="checkbox"/>	South Slip	<input checked="" type="checkbox"/>	Top of Wall

TOTAL:

STRAP WIDTH BEFORE TEST:

Front Right	Front Left, mm	Back Right, mm	Back Left, mm
	63.70	63.72	
	63.65	63.32	
	63.10	63.17	
AVG	63.48 mm	AVG	63.40 mm
		AVG	63.00 mm

DATA ACQ. RECORD RATE: 1 scan/sec **MONITOR RATE:** 10 scan/sec

COMMENTS:

- Shear anchors torqued for 10 s with impact wrench
- Hold down anchors 1/2 turn from finger tight (load cells used on both hold-downs)
- Ambient temperature 32 C
- Double chord studs used screwed back to back
- Square plate washers (2.5"x2.5") used in all top track connections
- Regular washers used in all bottom track connections

Figure C. 18 Data sheet for test 41 A-M

Cold Formed Steel Strap Braced Walls McGill University, Montreal																																										
TEST:	42 A-C																																									
RESEARCHER:	Kostadin Velchev	ASSISTANTS:	Gilles Comeau, Nisreen Balh																																							
DATE:	10-Aug-07		TIME:	12:58																																						
DIMENSIONS OF WALL:	8 FT X	8 FT X	6 IN.	INITIAL STRAP SURVEY:	Front Back	Right tight tight	Left tight tight																																			
STRAP FASTENER CONFIGURATION:				MFR:	McGill																																					
STRAP SIZE:	<table border="1" style="width:100%; border-collapse: collapse;"> <tr><td><input checked="" type="checkbox"/></td><td>2.5" 0.043" (1.09mm) 33 ksi (230 MPa)</td></tr> <tr><td><input type="checkbox"/></td><td>2.75" 0.054" (1.37mm) 50 ksi (340 MPa)</td></tr> <tr><td><input type="checkbox"/></td><td>4" 0.068" (1.73mm) 50 ksi (340 MPa)</td></tr> <tr><td><input type="checkbox"/></td><td>5" 0.043" (1.09) 33 ksi (230 MPa)</td></tr> <tr><td><input type="checkbox"/></td><td>Reduced section strap -- fuse = 2.5" wide x 30" long -- ends = 3.75" wide 0.043" (1.09mm) 33 ksi (230 MPa)</td></tr> <tr><td><input type="checkbox"/></td><td>Reduced section strap -- fuse = 2.75" wide x 30" long -- ends = 4.25" wide 0.054" (1.37mm) 50 ksi (340 MPa)</td></tr> <tr><td><input type="checkbox"/></td><td>Reduced section strap -- fuse = 4" wide x 30" long -- ends = 6" wide 0.068" (1.73mm) 50 ksi (340 MPa)</td></tr> <tr><td><input type="checkbox"/></td><td>Reduced section strap -- fuse = 2.5" wide x 60" long -- ends = 3.75" wide 0.043" (1.09mm) 33 ksi (230 MPa)</td></tr> <tr><td><input type="checkbox"/></td><td>Reduced section strap -- fuse = 4" wide x 60" long -- ends = 6" wide 0.068" (1.73mm) 50 ksi (340 MPa)</td></tr> </table>							<input checked="" type="checkbox"/>	2.5" 0.043" (1.09mm) 33 ksi (230 MPa)	<input type="checkbox"/>	2.75" 0.054" (1.37mm) 50 ksi (340 MPa)	<input type="checkbox"/>	4" 0.068" (1.73mm) 50 ksi (340 MPa)	<input type="checkbox"/>	5" 0.043" (1.09) 33 ksi (230 MPa)	<input type="checkbox"/>	Reduced section strap -- fuse = 2.5" wide x 30" long -- ends = 3.75" wide 0.043" (1.09mm) 33 ksi (230 MPa)	<input type="checkbox"/>	Reduced section strap -- fuse = 2.75" wide x 30" long -- ends = 4.25" wide 0.054" (1.37mm) 50 ksi (340 MPa)	<input type="checkbox"/>	Reduced section strap -- fuse = 4" wide x 30" long -- ends = 6" wide 0.068" (1.73mm) 50 ksi (340 MPa)	<input type="checkbox"/>	Reduced section strap -- fuse = 2.5" wide x 60" long -- ends = 3.75" wide 0.043" (1.09mm) 33 ksi (230 MPa)	<input type="checkbox"/>	Reduced section strap -- fuse = 4" wide x 60" long -- ends = 6" wide 0.068" (1.73mm) 50 ksi (340 MPa)																	
<input checked="" type="checkbox"/>	2.5" 0.043" (1.09mm) 33 ksi (230 MPa)																																									
<input type="checkbox"/>	2.75" 0.054" (1.37mm) 50 ksi (340 MPa)																																									
<input type="checkbox"/>	4" 0.068" (1.73mm) 50 ksi (340 MPa)																																									
<input type="checkbox"/>	5" 0.043" (1.09) 33 ksi (230 MPa)																																									
<input type="checkbox"/>	Reduced section strap -- fuse = 2.5" wide x 30" long -- ends = 3.75" wide 0.043" (1.09mm) 33 ksi (230 MPa)																																									
<input type="checkbox"/>	Reduced section strap -- fuse = 2.75" wide x 30" long -- ends = 4.25" wide 0.054" (1.37mm) 50 ksi (340 MPa)																																									
<input type="checkbox"/>	Reduced section strap -- fuse = 4" wide x 30" long -- ends = 6" wide 0.068" (1.73mm) 50 ksi (340 MPa)																																									
<input type="checkbox"/>	Reduced section strap -- fuse = 2.5" wide x 60" long -- ends = 3.75" wide 0.043" (1.09mm) 33 ksi (230 MPa)																																									
<input type="checkbox"/>	Reduced section strap -- fuse = 4" wide x 60" long -- ends = 6" wide 0.068" (1.73mm) 50 ksi (340 MPa)																																									
INTERIOR STUDS:	<table border="1" style="width:100%; border-collapse: collapse;"> <tr><td><input checked="" type="checkbox"/></td><td>3-5/8"Wx1-5/8"Fx1/2"Lip 0.043" (1.09mm) 33ksi (230 Mpa)</td></tr> <tr><td><input type="checkbox"/></td><td>6"Wx1-5/8"Fx1/2"Lip 0.043" (1.09mm) 33ksi (230 Mpa)</td></tr> </table>		<input checked="" type="checkbox"/>	3-5/8"Wx1-5/8"Fx1/2"Lip 0.043" (1.09mm) 33ksi (230 Mpa)	<input type="checkbox"/>	6"Wx1-5/8"Fx1/2"Lip 0.043" (1.09mm) 33ksi (230 Mpa)	STUD SPACING:	<table border="1" style="width:100%; border-collapse: collapse;"> <tr><td><input checked="" type="checkbox"/></td><td>16" O.C.</td></tr> <tr><td><input type="checkbox"/></td><td>Other : _____</td></tr> </table>			<input checked="" type="checkbox"/>	16" O.C.	<input type="checkbox"/>	Other : _____																												
<input checked="" type="checkbox"/>	3-5/8"Wx1-5/8"Fx1/2"Lip 0.043" (1.09mm) 33ksi (230 Mpa)																																									
<input type="checkbox"/>	6"Wx1-5/8"Fx1/2"Lip 0.043" (1.09mm) 33ksi (230 Mpa)																																									
<input checked="" type="checkbox"/>	16" O.C.																																									
<input type="checkbox"/>	Other : _____																																									
BACK-TO-BACK CHORD STUDS:	<table border="1" style="width:100%; border-collapse: collapse;"> <tr><td><input checked="" type="checkbox"/></td><td>3-5/8"Wx1-5/8"Fx1/2"Lip 0.043" (1.09mm) 33ksi (230 Mpa)</td></tr> <tr><td><input type="checkbox"/></td><td>6"Wx1-5/8"Fx1/2"Lip 0.054" (1.37mm) 50ksi (345 Mpa)</td></tr> <tr><td><input type="checkbox"/></td><td>6"Wx1-5/8"Fx1/2"Lip 0.068" (1.73mm) 50ksi (345 Mpa)</td></tr> </table>							<input checked="" type="checkbox"/>	3-5/8"Wx1-5/8"Fx1/2"Lip 0.043" (1.09mm) 33ksi (230 Mpa)	<input type="checkbox"/>	6"Wx1-5/8"Fx1/2"Lip 0.054" (1.37mm) 50ksi (345 Mpa)	<input type="checkbox"/>	6"Wx1-5/8"Fx1/2"Lip 0.068" (1.73mm) 50ksi (345 Mpa)																													
<input checked="" type="checkbox"/>	3-5/8"Wx1-5/8"Fx1/2"Lip 0.043" (1.09mm) 33ksi (230 Mpa)																																									
<input type="checkbox"/>	6"Wx1-5/8"Fx1/2"Lip 0.054" (1.37mm) 50ksi (345 Mpa)																																									
<input type="checkbox"/>	6"Wx1-5/8"Fx1/2"Lip 0.068" (1.73mm) 50ksi (345 Mpa)																																									
CONNECTIONS:	<table border="1" style="width:100%; border-collapse: collapse;"> <tr><td>Straps:</td><td><input checked="" type="checkbox"/></td><td>No.10 gauge 0.75" self-drilling wafer head (mod. Truss) Phillips drive</td></tr> <tr><td>Framing:</td><td><input checked="" type="checkbox"/></td><td>No.8 gauge 0.5" self-drilling wafer head (mod. Truss) Phillips drive</td></tr> <tr><td>Hold downs:</td><td><input type="checkbox"/></td><td></td></tr> <tr><td>Back-to-Back:</td><td><input type="checkbox"/></td><td></td></tr> <tr><td>Chord Studs:</td><td><input checked="" type="checkbox"/></td><td>No.10 gauge 0.75" self-drilling Hex washer head</td></tr> <tr><td>Anchor Rods:</td><td><input type="checkbox"/></td><td>7/8" A307</td></tr> <tr><td></td><td><input checked="" type="checkbox"/></td><td>1" Rod</td></tr> <tr><td>Loading Beam:</td><td><input checked="" type="checkbox"/></td><td>A325 3/4" bolts</td></tr> <tr><td>Base:</td><td><input checked="" type="checkbox"/></td><td>A325 3/4" bolts</td></tr> </table>							Straps:	<input checked="" type="checkbox"/>	No.10 gauge 0.75" self-drilling wafer head (mod. Truss) Phillips drive	Framing:	<input checked="" type="checkbox"/>	No.8 gauge 0.5" self-drilling wafer head (mod. Truss) Phillips drive	Hold downs:	<input type="checkbox"/>		Back-to-Back:	<input type="checkbox"/>		Chord Studs:	<input checked="" type="checkbox"/>	No.10 gauge 0.75" self-drilling Hex washer head	Anchor Rods:	<input type="checkbox"/>	7/8" A307		<input checked="" type="checkbox"/>	1" Rod	Loading Beam:	<input checked="" type="checkbox"/>	A325 3/4" bolts	Base:	<input checked="" type="checkbox"/>	A325 3/4" bolts								
Straps:	<input checked="" type="checkbox"/>	No.10 gauge 0.75" self-drilling wafer head (mod. Truss) Phillips drive																																								
Framing:	<input checked="" type="checkbox"/>	No.8 gauge 0.5" self-drilling wafer head (mod. Truss) Phillips drive																																								
Hold downs:	<input type="checkbox"/>																																									
Back-to-Back:	<input type="checkbox"/>																																									
Chord Studs:	<input checked="" type="checkbox"/>	No.10 gauge 0.75" self-drilling Hex washer head																																								
Anchor Rods:	<input type="checkbox"/>	7/8" A307																																								
	<input checked="" type="checkbox"/>	1" Rod																																								
Loading Beam:	<input checked="" type="checkbox"/>	A325 3/4" bolts																																								
Base:	<input checked="" type="checkbox"/>	A325 3/4" bolts																																								
TRACK:	<table border="1" style="width:100%; border-collapse: collapse;"> <tr><td><input checked="" type="checkbox"/></td><td>Regular</td><td><input type="checkbox"/></td><td>6" web</td><td><input checked="" type="checkbox"/></td><td>0.043" (1.09mm) 33ksi (230 Mpa)</td></tr> <tr><td><input type="checkbox"/></td><td>Extended</td><td><input checked="" type="checkbox"/></td><td>3 5/8" web</td><td><input type="checkbox"/></td><td>0.054" (1.37mm) 50ksi (345 Mpa)</td></tr> <tr><td><input type="checkbox"/></td><td>Reinforced</td><td><input type="checkbox"/></td><td>1-1/4" flange</td><td><input type="checkbox"/></td><td>0.068" (1.73mm) 50ksi (345 Mpa)</td></tr> </table>							<input checked="" type="checkbox"/>	Regular	<input type="checkbox"/>	6" web	<input checked="" type="checkbox"/>	0.043" (1.09mm) 33ksi (230 Mpa)	<input type="checkbox"/>	Extended	<input checked="" type="checkbox"/>	3 5/8" web	<input type="checkbox"/>	0.054" (1.37mm) 50ksi (345 Mpa)	<input type="checkbox"/>	Reinforced	<input type="checkbox"/>	1-1/4" flange	<input type="checkbox"/>	0.068" (1.73mm) 50ksi (345 Mpa)																	
<input checked="" type="checkbox"/>	Regular	<input type="checkbox"/>	6" web	<input checked="" type="checkbox"/>	0.043" (1.09mm) 33ksi (230 Mpa)																																					
<input type="checkbox"/>	Extended	<input checked="" type="checkbox"/>	3 5/8" web	<input type="checkbox"/>	0.054" (1.37mm) 50ksi (345 Mpa)																																					
<input type="checkbox"/>	Reinforced	<input type="checkbox"/>	1-1/4" flange	<input type="checkbox"/>	0.068" (1.73mm) 50ksi (345 Mpa)																																					
HOLD DOWNS:	<table border="1" style="width:100%; border-collapse: collapse;"> <tr><td><input checked="" type="checkbox"/></td><td>S/HD10S Simpson</td><td style="text-align: center;">inside</td><td style="text-align: center;">outside</td><td style="text-align: center;">raised</td></tr> <tr><td><input type="checkbox"/></td><td>Fabricated U-shape</td><td></td><td></td><td></td></tr> <tr><td><input type="checkbox"/></td><td>6" x 6" 0.054" (1.37mm) 50 ksi (340 MPa) Gusset Plate w/ S/HD15S Simpson</td><td></td><td></td><td></td></tr> <tr><td><input type="checkbox"/></td><td>7" x 9" 0.054" (1.37mm) 50 ksi (340 MPa) Gusset Plate w/ S/HD15S Simpson</td><td></td><td></td><td></td></tr> <tr><td><input type="checkbox"/></td><td>8" x 8" 0.068" (1.73mm) 50 ksi (340 MPa) Gusset Plate w/ S/HD15S Simpson</td><td></td><td></td><td></td></tr> <tr><td><input type="checkbox"/></td><td>8.5" x 10" 0.068" (1.73mm) 50 ksi (340 MPa) Gusset Plate w/ S/HD15S Simpson</td><td></td><td></td><td></td></tr> <tr><td><input type="checkbox"/></td><td>10" x 10" 0.054" (1.37mm) 50 ksi (340 MPa) Gusset Plate w/ S/HD15S Simpson</td><td></td><td></td><td></td></tr> </table>							<input checked="" type="checkbox"/>	S/HD10S Simpson	inside	outside	raised	<input type="checkbox"/>	Fabricated U-shape				<input type="checkbox"/>	6" x 6" 0.054" (1.37mm) 50 ksi (340 MPa) Gusset Plate w/ S/HD15S Simpson				<input type="checkbox"/>	7" x 9" 0.054" (1.37mm) 50 ksi (340 MPa) Gusset Plate w/ S/HD15S Simpson				<input type="checkbox"/>	8" x 8" 0.068" (1.73mm) 50 ksi (340 MPa) Gusset Plate w/ S/HD15S Simpson				<input type="checkbox"/>	8.5" x 10" 0.068" (1.73mm) 50 ksi (340 MPa) Gusset Plate w/ S/HD15S Simpson				<input type="checkbox"/>	10" x 10" 0.054" (1.37mm) 50 ksi (340 MPa) Gusset Plate w/ S/HD15S Simpson			
<input checked="" type="checkbox"/>	S/HD10S Simpson	inside	outside	raised																																						
<input type="checkbox"/>	Fabricated U-shape																																									
<input type="checkbox"/>	6" x 6" 0.054" (1.37mm) 50 ksi (340 MPa) Gusset Plate w/ S/HD15S Simpson																																									
<input type="checkbox"/>	7" x 9" 0.054" (1.37mm) 50 ksi (340 MPa) Gusset Plate w/ S/HD15S Simpson																																									
<input type="checkbox"/>	8" x 8" 0.068" (1.73mm) 50 ksi (340 MPa) Gusset Plate w/ S/HD15S Simpson																																									
<input type="checkbox"/>	8.5" x 10" 0.068" (1.73mm) 50 ksi (340 MPa) Gusset Plate w/ S/HD15S Simpson																																									
<input type="checkbox"/>	10" x 10" 0.054" (1.37mm) 50 ksi (340 MPa) Gusset Plate w/ S/HD15S Simpson																																									
TEST PROTOCOL AND DESCRIPTION:	<table border="1" style="width:100%; border-collapse: collapse;"> <tr><td><input type="checkbox"/></td><td>Monotonic (Rate of Loading 2.5 mm/min)</td></tr> <tr><td><input checked="" type="checkbox"/></td><td>Cyclic (CUREE cyclic protocol)</td></tr> </table>							<input type="checkbox"/>	Monotonic (Rate of Loading 2.5 mm/min)	<input checked="" type="checkbox"/>	Cyclic (CUREE cyclic protocol)																															
<input type="checkbox"/>	Monotonic (Rate of Loading 2.5 mm/min)																																									
<input checked="" type="checkbox"/>	Cyclic (CUREE cyclic protocol)																																									
LVDT MEASUREMENTS:	<table border="1" style="width:100%; border-collapse: collapse;"> <tr><td><input checked="" type="checkbox"/></td><td>Actuator LVDT</td><td><input checked="" type="checkbox"/></td><td>North Uplift</td></tr> <tr><td><input checked="" type="checkbox"/></td><td>North Slip</td><td><input checked="" type="checkbox"/></td><td>South Uplift</td></tr> <tr><td><input checked="" type="checkbox"/></td><td>South Slip</td><td><input checked="" type="checkbox"/></td><td>Top of Wall</td></tr> </table>							<input checked="" type="checkbox"/>	Actuator LVDT	<input checked="" type="checkbox"/>	North Uplift	<input checked="" type="checkbox"/>	North Slip	<input checked="" type="checkbox"/>	South Uplift	<input checked="" type="checkbox"/>	South Slip	<input checked="" type="checkbox"/>	Top of Wall																							
<input checked="" type="checkbox"/>	Actuator LVDT	<input checked="" type="checkbox"/>	North Uplift																																							
<input checked="" type="checkbox"/>	North Slip	<input checked="" type="checkbox"/>	South Uplift																																							
<input checked="" type="checkbox"/>	South Slip	<input checked="" type="checkbox"/>	Top of Wall																																							
				TOTAL:	6																																					
STRAP WIDTH BEFORE TEST:	<table border="1" style="width:100%; border-collapse: collapse;"> <tr><td></td><td>Front Right</td><td>Front Left, mm</td><td>Back Right, mm</td><td>Back Left, mm</td></tr> <tr><td></td><td>63.43</td><td>63.20</td><td>63.13</td><td>63.76</td></tr> <tr><td></td><td>63.77</td><td>63.47</td><td>63.35</td><td>63.21</td></tr> <tr><td></td><td>63.35</td><td>63.65</td><td>63.77</td><td>63.01</td></tr> <tr><td></td><td>AVG 63.52</td><td>AVG 63.44 mm</td><td>AVG 63.42 mm</td><td>AVG 63.33 mm</td></tr> </table>								Front Right	Front Left, mm	Back Right, mm	Back Left, mm		63.43	63.20	63.13	63.76		63.77	63.47	63.35	63.21		63.35	63.65	63.77	63.01		AVG 63.52	AVG 63.44 mm	AVG 63.42 mm	AVG 63.33 mm										
	Front Right	Front Left, mm	Back Right, mm	Back Left, mm																																						
	63.43	63.20	63.13	63.76																																						
	63.77	63.47	63.35	63.21																																						
	63.35	63.65	63.77	63.01																																						
	AVG 63.52	AVG 63.44 mm	AVG 63.42 mm	AVG 63.33 mm																																						
DATA ACQ. RECORD RATE:	100 scan/sec			MONITOR RATE:	100 scan/sec																																					
COMMENTS:	<ul style="list-style-type: none"> -Shear anchors torqued for 10 s with impact wrench -Hold down anchors 1/2 turn from finger tight (load cells used on both hold-downs) -Ambient temperature 29 C -Double chord studs used screwed back to back -Square plate washers (2.5"x2.5") used in all top track connections -Regular washers used in all bottom track connections 																																									

Figure C. 19 Data sheet for test 42 A-C

Cold Formed Steel Strap Braced Walls
McGill University, Montreal

TEST: 43 A-M

RESEARCHER: Kostadin Velchev **ASSISTANTS:** Gilles Comeau, Nisreen Balh

DATE: 9-Aug-07 **TIME:** 14:09

DIMENSIONS OF WALL: 8 FT X 8 FT X 6 IN. **INITIAL STRAP SURVEY:** Front Right Left
Back tight tight

STRAP FASTENER CONFIGURATION: MFR: McGill

STRAP SIZE:

<input type="checkbox"/>	2.5" 0.043" (1.09mm) 33 ksi (230 MPa)
<input type="checkbox"/>	2.75" 0.054" (1.37mm) 50 ksi (340 MPa)
<input checked="" type="checkbox"/>	4" 0.068" (1.73mm) 50 ksi (340 MPa)
<input type="checkbox"/>	5" 0.043" (1.09) 33 ksi (230 MPa)
<input type="checkbox"/>	Reduced section strap -- fuse = 2.5" wide x 30" long -- ends = 3.75" wide 0.043" (1.09mm) 33 ksi (230 MPa)
<input type="checkbox"/>	Reduced section strap -- fuse = 2.75" wide x 30" long -- ends = 4.25" wide 0.054" (1.37mm) 50 ksi (340 MPa)
<input type="checkbox"/>	Reduced section strap -- fuse = 4" wide x 30" long -- ends = 6" wide 0.068" (1.73mm) 50 ksi (340 MPa)
<input type="checkbox"/>	Reduced section strap -- fuse = 2.5" wide x 60" long -- ends = 3.75" wide 0.043" (1.09mm) 33 ksi (230 MPa)
<input type="checkbox"/>	Reduced section strap -- fuse = 4" wide x 60" long -- ends = 6" wide 0.068" (1.73mm) 50 ksi (340 MPa)

INTERIOR STUDS:

<input type="checkbox"/>	3-5/8"Wx1-5/8"Fx1/2"Lip 0.043" (1.09mm) 33ksi (230 Mpa)
<input checked="" type="checkbox"/>	6"Wx1-5/8"Fx1/2"Lip 0.043" (1.09mm) 33ksi (230 Mpa)

STUD SPACING: 16" O.C. Other: _____

BACK-TO-BACK CHORD STUDS:

<input type="checkbox"/>	3-5/8"Wx1-5/8"Fx1/2"Lip 0.043" (1.09mm) 33ksi (230 Mpa)
<input type="checkbox"/>	6"Wx1-5/8"Fx1/2"Lip 0.054" (1.37mm) 50ksi (345 Mpa)
<input checked="" type="checkbox"/>	6"Wx1-5/8"Fx1/2"Lip 0.068" (1.73mm) 50ksi (345 Mpa)

CONNECTIONS:

<input checked="" type="checkbox"/>	Straps	No. 10 gauge 0.75" self-drilling wafer head (mod. Truss) Phillips drive
<input checked="" type="checkbox"/>	Framing:	No. 8 gauge 0.5" self-drilling wafer head (mod. Truss) Phillips drive
<input type="checkbox"/>	Hold downs:	
<input type="checkbox"/>	Back-to-Back	
<input checked="" type="checkbox"/>	Chord Studs:	No. 10 gauge 0.75" self-drilling Hex washer head
<input type="checkbox"/>	Anchor Rods:	7/8" A307
<input type="checkbox"/>		1" Rod
<input checked="" type="checkbox"/>	Loading Beam:	A325 3/4" bolts
<input checked="" type="checkbox"/>	Base:	A325 3/4" bolts

10 bolts 2 Anchor Rods
6 bolts 2 Anchor Rods

TRACK:

<input checked="" type="checkbox"/>	Regular	6" web	<input type="checkbox"/>	0.043" (1.09mm) 33ksi (230 Mpa)
<input type="checkbox"/>	Extended	3 5/8" web	<input type="checkbox"/>	0.054" (1.37mm) 50ksi (345 Mpa)
<input type="checkbox"/>	Reinforced	1-1/4" flange	<input checked="" type="checkbox"/>	0.068" (1.73mm) 50ksi (345 Mpa)

HOLD DOWNS:

<input type="checkbox"/>	S/HD10S Simpson	inside	outside	raised
<input checked="" type="checkbox"/>	Fabricated U-shape			
<input type="checkbox"/>	6" x 6" 0.054" (1.37mm) 50 ksi (340 MPa) Gusset Plate w/ S/HD15S Simpson			
<input type="checkbox"/>	7" x 9" 0.054" (1.37mm) 50 ksi (340 MPa) Gusset Plate w/ S/HD15S Simpson			
<input type="checkbox"/>	8" x 8" 0.068" (1.73mm) 50 ksi (340 MPa) Gusset Plate w/ S/HD15S Simpson			
<input type="checkbox"/>	8.5" x 10" 0.068" (1.73mm) 50 ksi (340 MPa) Gusset Plate w/ S/HD15S Simpson			
<input type="checkbox"/>	10" x 10" 0.054" (1.37mm) 50 ksi (340 MPa) Gusset Plate w/ S/HD15S Simpson			

TEST PROTOCOL AND DESCRIPTION:

<input checked="" type="checkbox"/>	Monotonic (Rate of Loading 2.5 mm/min)
<input type="checkbox"/>	Cyclic (CUREE cyclic protocol)

LVDT MEASUREMENTS:

<input checked="" type="checkbox"/>	Actuator LVDT	<input checked="" type="checkbox"/>	North Uplift
<input checked="" type="checkbox"/>	North Slip	<input checked="" type="checkbox"/>	South Uplift
<input checked="" type="checkbox"/>	South Slip	<input checked="" type="checkbox"/>	Top of Wall

TOTAL:

STRAP WIDTH BEFORE TEST:

	Front Right	Front Left, mm	Back Right, mm	Back Left, mm
		101.56	101.61	
		101.02	101.34	
		101.23	102.26	
	AVG	101.27 mm	AVG	101.74 mm
			AVG	101.00 mm

DATA ACQ. RECORD RATE: 1 scan/sec **MONITOR RATE:** 10 scan/sec

COMMENTS:

- Shear anchors torqued for 10 s with impact wrench
- Hold down anchors 1/2 turn from finger tight (load cells used on both hold-downs)
- Ambient temperature 28 C
- Double chord studs used screwed back to back
- Square plate washers (2.5"x2.5") used in all top track connections
- Regular washers used in all bottom track connections

Figure C. 20 Data sheet for test 43 A-M

Cold Formed Steel Strap Braced Walls																																												
McGill University, Montreal																																												
TEST:		44 A-C																																										
RESEARCHER:		Kostadin Velchev		ASSISTANTS:																																								
				Gilles Comeau, Nisreen Balh																																								
DATE:		10-Aug-07		TIME:																																								
				10:34																																								
DIMENSIONS OF WALL:		8 FT X	8 FT X	6 IN.	INITIAL STRAP SURVEY:																																							
					Front Right Left Back tight tight tight tight																																							
STRAP FASTENER CONFIGURATION:			MFR: McGill																																									
STRAP SIZE:		<table border="1" style="width:100%; border-collapse: collapse;"> <tr><td><input type="checkbox"/></td><td>2.5" 0.043" (1.09mm) 33 ksi (230 MPa)</td></tr> <tr><td><input type="checkbox"/></td><td>2.75" 0.054" (1.37mm) 50 ksi (340 MPa)</td></tr> <tr><td><input checked="" type="checkbox"/></td><td>4" 0.068" (1.73mm) 50 ksi (340 MPa)</td></tr> <tr><td><input type="checkbox"/></td><td>5" 0.043" (1.09) 33 ksi (230 MPa)</td></tr> <tr><td><input type="checkbox"/></td><td>Reduced section strap -- fuse = 2.5" wide x 30" long -- ends = 3.75" wide 0.043" (1.09mm) 33 ksi (230 MPa)</td></tr> <tr><td><input type="checkbox"/></td><td>Reduced section strap -- fuse = 2.75" wide x 30" long -- ends = 4.25" wide 0.054" (1.37mm) 50 ksi (340 MPa)</td></tr> <tr><td><input type="checkbox"/></td><td>Reduced section strap -- fuse = 4" wide x 30" long -- ends = 6" wide 0.068" (1.73mm) 50 ksi (340 MPa)</td></tr> <tr><td><input type="checkbox"/></td><td>Reduced section strap -- fuse = 2.5" wide x 60" long -- ends = 3.75" wide 0.043" (1.09mm) 33 ksi (230 MPa)</td></tr> <tr><td><input type="checkbox"/></td><td>Reduced section strap -- fuse = 4" wide x 60" long -- ends = 6" wide 0.068" (1.73mm) 50 ksi (340 MPa)</td></tr> </table>				<input type="checkbox"/>	2.5" 0.043" (1.09mm) 33 ksi (230 MPa)	<input type="checkbox"/>	2.75" 0.054" (1.37mm) 50 ksi (340 MPa)	<input checked="" type="checkbox"/>	4" 0.068" (1.73mm) 50 ksi (340 MPa)	<input type="checkbox"/>	5" 0.043" (1.09) 33 ksi (230 MPa)	<input type="checkbox"/>	Reduced section strap -- fuse = 2.5" wide x 30" long -- ends = 3.75" wide 0.043" (1.09mm) 33 ksi (230 MPa)	<input type="checkbox"/>	Reduced section strap -- fuse = 2.75" wide x 30" long -- ends = 4.25" wide 0.054" (1.37mm) 50 ksi (340 MPa)	<input type="checkbox"/>	Reduced section strap -- fuse = 4" wide x 30" long -- ends = 6" wide 0.068" (1.73mm) 50 ksi (340 MPa)	<input type="checkbox"/>	Reduced section strap -- fuse = 2.5" wide x 60" long -- ends = 3.75" wide 0.043" (1.09mm) 33 ksi (230 MPa)	<input type="checkbox"/>	Reduced section strap -- fuse = 4" wide x 60" long -- ends = 6" wide 0.068" (1.73mm) 50 ksi (340 MPa)																					
<input type="checkbox"/>	2.5" 0.043" (1.09mm) 33 ksi (230 MPa)																																											
<input type="checkbox"/>	2.75" 0.054" (1.37mm) 50 ksi (340 MPa)																																											
<input checked="" type="checkbox"/>	4" 0.068" (1.73mm) 50 ksi (340 MPa)																																											
<input type="checkbox"/>	5" 0.043" (1.09) 33 ksi (230 MPa)																																											
<input type="checkbox"/>	Reduced section strap -- fuse = 2.5" wide x 30" long -- ends = 3.75" wide 0.043" (1.09mm) 33 ksi (230 MPa)																																											
<input type="checkbox"/>	Reduced section strap -- fuse = 2.75" wide x 30" long -- ends = 4.25" wide 0.054" (1.37mm) 50 ksi (340 MPa)																																											
<input type="checkbox"/>	Reduced section strap -- fuse = 4" wide x 30" long -- ends = 6" wide 0.068" (1.73mm) 50 ksi (340 MPa)																																											
<input type="checkbox"/>	Reduced section strap -- fuse = 2.5" wide x 60" long -- ends = 3.75" wide 0.043" (1.09mm) 33 ksi (230 MPa)																																											
<input type="checkbox"/>	Reduced section strap -- fuse = 4" wide x 60" long -- ends = 6" wide 0.068" (1.73mm) 50 ksi (340 MPa)																																											
INTERIOR STUDS:		<table border="1" style="width:100%; border-collapse: collapse;"> <tr><td><input type="checkbox"/></td><td>3-5/8"Wx1-5/8"Fx1/2"Lip 0.043" (1.09mm) 33ksi (230 Mpa)</td></tr> <tr><td><input checked="" type="checkbox"/></td><td>6"Wx1-5/8"Fx1/2"Lip 0.043" (1.09mm) 33ksi (230 Mpa)</td></tr> </table>		<input type="checkbox"/>	3-5/8"Wx1-5/8"Fx1/2"Lip 0.043" (1.09mm) 33ksi (230 Mpa)	<input checked="" type="checkbox"/>	6"Wx1-5/8"Fx1/2"Lip 0.043" (1.09mm) 33ksi (230 Mpa)	STUD SPACING:		<table border="1" style="width:100%; border-collapse: collapse;"> <tr><td><input checked="" type="checkbox"/></td><td>16" O.C.</td></tr> <tr><td><input type="checkbox"/></td><td>Other : _____</td></tr> </table>	<input checked="" type="checkbox"/>	16" O.C.	<input type="checkbox"/>	Other : _____																														
<input type="checkbox"/>	3-5/8"Wx1-5/8"Fx1/2"Lip 0.043" (1.09mm) 33ksi (230 Mpa)																																											
<input checked="" type="checkbox"/>	6"Wx1-5/8"Fx1/2"Lip 0.043" (1.09mm) 33ksi (230 Mpa)																																											
<input checked="" type="checkbox"/>	16" O.C.																																											
<input type="checkbox"/>	Other : _____																																											
BACK-TO-BACK CHORD STUDS:		<table border="1" style="width:100%; border-collapse: collapse;"> <tr><td><input type="checkbox"/></td><td>3-5/8"Wx1-5/8"Fx1/2"Lip 0.043" (1.09mm) 33ksi (230 Mpa)</td></tr> <tr><td><input type="checkbox"/></td><td>6"Wx1-5/8"Fx1/2"Lip 0.054" (1.37mm) 50ksi (345 Mpa)</td></tr> <tr><td><input checked="" type="checkbox"/></td><td>6"Wx1-5/8"Fx1/2"Lip 0.068" (1.73mm) 50ksi (345 Mpa)</td></tr> </table>				<input type="checkbox"/>	3-5/8"Wx1-5/8"Fx1/2"Lip 0.043" (1.09mm) 33ksi (230 Mpa)	<input type="checkbox"/>	6"Wx1-5/8"Fx1/2"Lip 0.054" (1.37mm) 50ksi (345 Mpa)	<input checked="" type="checkbox"/>	6"Wx1-5/8"Fx1/2"Lip 0.068" (1.73mm) 50ksi (345 Mpa)																																	
<input type="checkbox"/>	3-5/8"Wx1-5/8"Fx1/2"Lip 0.043" (1.09mm) 33ksi (230 Mpa)																																											
<input type="checkbox"/>	6"Wx1-5/8"Fx1/2"Lip 0.054" (1.37mm) 50ksi (345 Mpa)																																											
<input checked="" type="checkbox"/>	6"Wx1-5/8"Fx1/2"Lip 0.068" (1.73mm) 50ksi (345 Mpa)																																											
CONNECTIONS:		<table border="1" style="width:100%; border-collapse: collapse;"> <tr><td><input checked="" type="checkbox"/></td><td>Straps</td><td>No.10 gauge 0.75" self-drilling wafer head (mod. Truss) Phillips drive</td></tr> <tr><td><input checked="" type="checkbox"/></td><td>Framing:</td><td>No.8 gauge 0.5" self-drilling wafer head (mod. Truss) Phillips drive</td></tr> <tr><td><input type="checkbox"/></td><td>Hold downs:</td><td></td></tr> <tr><td><input type="checkbox"/></td><td>Back-to-Back</td><td></td></tr> <tr><td><input checked="" type="checkbox"/></td><td>Chord Studs:</td><td>No.10 gauge 0.75" self-drilling Hex washer head</td></tr> <tr><td><input type="checkbox"/></td><td>Anchor Rods:</td><td>7/8" A307</td></tr> <tr><td><input checked="" type="checkbox"/></td><td></td><td>1" Rod</td></tr> <tr><td><input checked="" type="checkbox"/></td><td>Loading Beam:</td><td>A325 3/4" bolts</td></tr> <tr><td><input checked="" type="checkbox"/></td><td>Base</td><td>A325 3/4" bolts</td></tr> <tr><td><input type="checkbox"/></td><td></td><td>10 bolts</td></tr> <tr><td><input checked="" type="checkbox"/></td><td></td><td>6 bolts</td></tr> <tr><td><input type="checkbox"/></td><td></td><td>2 Anchor Rods</td></tr> <tr><td><input checked="" type="checkbox"/></td><td></td><td>2 Anchor Rods</td></tr> </table>				<input checked="" type="checkbox"/>	Straps	No.10 gauge 0.75" self-drilling wafer head (mod. Truss) Phillips drive	<input checked="" type="checkbox"/>	Framing:	No.8 gauge 0.5" self-drilling wafer head (mod. Truss) Phillips drive	<input type="checkbox"/>	Hold downs:		<input type="checkbox"/>	Back-to-Back		<input checked="" type="checkbox"/>	Chord Studs:	No.10 gauge 0.75" self-drilling Hex washer head	<input type="checkbox"/>	Anchor Rods:	7/8" A307	<input checked="" type="checkbox"/>		1" Rod	<input checked="" type="checkbox"/>	Loading Beam:	A325 3/4" bolts	<input checked="" type="checkbox"/>	Base	A325 3/4" bolts	<input type="checkbox"/>		10 bolts	<input checked="" type="checkbox"/>		6 bolts	<input type="checkbox"/>		2 Anchor Rods	<input checked="" type="checkbox"/>		2 Anchor Rods
<input checked="" type="checkbox"/>	Straps	No.10 gauge 0.75" self-drilling wafer head (mod. Truss) Phillips drive																																										
<input checked="" type="checkbox"/>	Framing:	No.8 gauge 0.5" self-drilling wafer head (mod. Truss) Phillips drive																																										
<input type="checkbox"/>	Hold downs:																																											
<input type="checkbox"/>	Back-to-Back																																											
<input checked="" type="checkbox"/>	Chord Studs:	No.10 gauge 0.75" self-drilling Hex washer head																																										
<input type="checkbox"/>	Anchor Rods:	7/8" A307																																										
<input checked="" type="checkbox"/>		1" Rod																																										
<input checked="" type="checkbox"/>	Loading Beam:	A325 3/4" bolts																																										
<input checked="" type="checkbox"/>	Base	A325 3/4" bolts																																										
<input type="checkbox"/>		10 bolts																																										
<input checked="" type="checkbox"/>		6 bolts																																										
<input type="checkbox"/>		2 Anchor Rods																																										
<input checked="" type="checkbox"/>		2 Anchor Rods																																										
TRACK:		<table border="1" style="width:100%; border-collapse: collapse;"> <tr><td><input checked="" type="checkbox"/></td><td>Regular</td><td>6" web</td><td><input checked="" type="checkbox"/></td><td>0.043" (1.09mm) 33ksi (230 Mpa)</td></tr> <tr><td><input type="checkbox"/></td><td>Extended</td><td>3 5/8" web</td><td><input type="checkbox"/></td><td>0.054" (1.37mm) 50ksi (345 Mpa)</td></tr> <tr><td><input type="checkbox"/></td><td>Reinforced</td><td>1-1/4" flange</td><td><input type="checkbox"/></td><td>0.068" (1.73mm) 50ksi (345 Mpa)</td></tr> </table>				<input checked="" type="checkbox"/>	Regular	6" web	<input checked="" type="checkbox"/>	0.043" (1.09mm) 33ksi (230 Mpa)	<input type="checkbox"/>	Extended	3 5/8" web	<input type="checkbox"/>	0.054" (1.37mm) 50ksi (345 Mpa)	<input type="checkbox"/>	Reinforced	1-1/4" flange	<input type="checkbox"/>	0.068" (1.73mm) 50ksi (345 Mpa)																								
<input checked="" type="checkbox"/>	Regular	6" web	<input checked="" type="checkbox"/>	0.043" (1.09mm) 33ksi (230 Mpa)																																								
<input type="checkbox"/>	Extended	3 5/8" web	<input type="checkbox"/>	0.054" (1.37mm) 50ksi (345 Mpa)																																								
<input type="checkbox"/>	Reinforced	1-1/4" flange	<input type="checkbox"/>	0.068" (1.73mm) 50ksi (345 Mpa)																																								
HOLD DOWNS:		<table border="1" style="width:100%; border-collapse: collapse;"> <tr><td><input checked="" type="checkbox"/></td><td>S/HD10S Simpson</td><td></td><td></td><td></td></tr> <tr><td><input type="checkbox"/></td><td>Fabricated U-shape</td><td></td><td></td><td></td></tr> <tr><td><input type="checkbox"/></td><td>6" x 6" 0.054" (1.37mm) 50 ksi (340 MPa) Gusset Plate w/ S/HD15S Simpson</td><td>inside</td><td>outside</td><td>raised</td></tr> <tr><td><input type="checkbox"/></td><td>7" x 9" 0.054" (1.37mm) 50 ksi (340 MPa) Gusset Plate w/ S/HD15S Simpson</td><td></td><td></td><td></td></tr> <tr><td><input type="checkbox"/></td><td>8" x 8" 0.068" (1.73mm) 50 ksi (340 MPa) Gusset Plate w/ S/HD15S Simpson</td><td></td><td></td><td></td></tr> <tr><td><input type="checkbox"/></td><td>8.5" x10" 0.068" (1.73mm) 50 ksi (340 MPa) Gusset Plate w/ S/HD15S Simpson</td><td></td><td></td><td></td></tr> <tr><td><input type="checkbox"/></td><td>10" x10" 0.054" (1.37mm) 50 ksi (340 MPa) Gusset Plate w/ S/HD15S Simpson</td><td></td><td></td><td></td></tr> </table>				<input checked="" type="checkbox"/>	S/HD10S Simpson				<input type="checkbox"/>	Fabricated U-shape				<input type="checkbox"/>	6" x 6" 0.054" (1.37mm) 50 ksi (340 MPa) Gusset Plate w/ S/HD15S Simpson	inside	outside	raised	<input type="checkbox"/>	7" x 9" 0.054" (1.37mm) 50 ksi (340 MPa) Gusset Plate w/ S/HD15S Simpson				<input type="checkbox"/>	8" x 8" 0.068" (1.73mm) 50 ksi (340 MPa) Gusset Plate w/ S/HD15S Simpson				<input type="checkbox"/>	8.5" x10" 0.068" (1.73mm) 50 ksi (340 MPa) Gusset Plate w/ S/HD15S Simpson				<input type="checkbox"/>	10" x10" 0.054" (1.37mm) 50 ksi (340 MPa) Gusset Plate w/ S/HD15S Simpson							
<input checked="" type="checkbox"/>	S/HD10S Simpson																																											
<input type="checkbox"/>	Fabricated U-shape																																											
<input type="checkbox"/>	6" x 6" 0.054" (1.37mm) 50 ksi (340 MPa) Gusset Plate w/ S/HD15S Simpson	inside	outside	raised																																								
<input type="checkbox"/>	7" x 9" 0.054" (1.37mm) 50 ksi (340 MPa) Gusset Plate w/ S/HD15S Simpson																																											
<input type="checkbox"/>	8" x 8" 0.068" (1.73mm) 50 ksi (340 MPa) Gusset Plate w/ S/HD15S Simpson																																											
<input type="checkbox"/>	8.5" x10" 0.068" (1.73mm) 50 ksi (340 MPa) Gusset Plate w/ S/HD15S Simpson																																											
<input type="checkbox"/>	10" x10" 0.054" (1.37mm) 50 ksi (340 MPa) Gusset Plate w/ S/HD15S Simpson																																											
TEST PROTOCOL AND DESCRIPTION:		<table border="1" style="width:100%; border-collapse: collapse;"> <tr><td><input type="checkbox"/></td><td>Monotonic (Rate of Loading 2.5 mm/min)</td></tr> <tr><td><input checked="" type="checkbox"/></td><td>Cyclic (CUREE cyclic protocol)</td></tr> </table>				<input type="checkbox"/>	Monotonic (Rate of Loading 2.5 mm/min)	<input checked="" type="checkbox"/>	Cyclic (CUREE cyclic protocol)																																			
<input type="checkbox"/>	Monotonic (Rate of Loading 2.5 mm/min)																																											
<input checked="" type="checkbox"/>	Cyclic (CUREE cyclic protocol)																																											
LVDT MEASUREMENTS:		<table border="1" style="width:100%; border-collapse: collapse;"> <tr><td><input checked="" type="checkbox"/></td><td>Actuator LVDT</td><td><input checked="" type="checkbox"/></td><td>North Uplift</td></tr> <tr><td><input checked="" type="checkbox"/></td><td>North Slip</td><td><input checked="" type="checkbox"/></td><td>South Uplift</td></tr> <tr><td><input checked="" type="checkbox"/></td><td>South Slip</td><td><input checked="" type="checkbox"/></td><td>Top of Wall</td></tr> </table>				<input checked="" type="checkbox"/>	Actuator LVDT	<input checked="" type="checkbox"/>	North Uplift	<input checked="" type="checkbox"/>	North Slip	<input checked="" type="checkbox"/>	South Uplift	<input checked="" type="checkbox"/>	South Slip	<input checked="" type="checkbox"/>	Top of Wall																											
<input checked="" type="checkbox"/>	Actuator LVDT	<input checked="" type="checkbox"/>	North Uplift																																									
<input checked="" type="checkbox"/>	North Slip	<input checked="" type="checkbox"/>	South Uplift																																									
<input checked="" type="checkbox"/>	South Slip	<input checked="" type="checkbox"/>	Top of Wall																																									
		TOTAL: <input type="text" value="6"/>																																										
STRAP WIDTH BEFORE TEST:		<table border="1" style="width:100%; border-collapse: collapse;"> <tr> <th>Front Right</th> <th>Front Left, mm</th> <th>Back Right, mm</th> <th>Back Left, mm</th> </tr> <tr> <td>102.23</td> <td>102.81</td> <td>102.70</td> <td>102.30</td> </tr> <tr> <td>102.42</td> <td>102.42</td> <td>102.34</td> <td>102.46</td> </tr> <tr> <td>102.73</td> <td>102.30</td> <td>102.50</td> <td>102.68</td> </tr> <tr> <td>AVG</td> <td>102.46</td> <td>AVG</td> <td>102.51 mm</td> </tr> <tr> <td></td> <td></td> <td>AVG</td> <td>102.51 mm</td> </tr> <tr> <td></td> <td></td> <td>AVG</td> <td>102.48 mm</td> </tr> </table>				Front Right	Front Left, mm	Back Right, mm	Back Left, mm	102.23	102.81	102.70	102.30	102.42	102.42	102.34	102.46	102.73	102.30	102.50	102.68	AVG	102.46	AVG	102.51 mm			AVG	102.51 mm			AVG	102.48 mm											
Front Right	Front Left, mm	Back Right, mm	Back Left, mm																																									
102.23	102.81	102.70	102.30																																									
102.42	102.42	102.34	102.46																																									
102.73	102.30	102.50	102.68																																									
AVG	102.46	AVG	102.51 mm																																									
		AVG	102.51 mm																																									
		AVG	102.48 mm																																									
DATA ACQ. RECORD RATE:		100 scan/sec		MONITOR RATE:																																								
				100 scan/sec																																								
COMMENTS:		<ul style="list-style-type: none"> -Shear anchors torqued for 10 s with impact wrench -Hold down anchors 1/2 turn from finger tight (load cells used on both hold-downs) -Ambient temperature 28 C -Double chord studs used screwed back to back -Square plate washers (2.5"x2.5") used in all top track connections -Regular washers used in all bottom track connections 																																										

Figure C. 21 Data sheet for test 44 A-C

Cold Formed Steel Strap Braced Walls McGill University, Montreal																																																								
TEST:	45 A-M																																																							
RESEARCHER:	Kostadin Velchev	ASSISTANTS:	Gilles Comeau, Nisreen Balh																																																					
DATE:	25-May-07		TIME:	11:04																																																				
DIMENSIONS OF WALL:	8 FT X	8 FT X	6 IN.	INITIAL STRAP SURVEY:	Front Back	Right tight tight	Left tight tight																																																	
STRAP FASTENER CONFIGURATION:				MFR:	McGill																																																			
STRAP SIZE:	<table border="0" style="width:100%;"> <tr><td><input type="checkbox"/></td><td>2.5" 0.043" (1.09mm) 33 ksi (230 MPa)</td></tr> <tr><td><input type="checkbox"/></td><td>2.75" 0.054" (1.37mm) 50 ksi (340 MPa)</td></tr> <tr><td><input checked="" type="checkbox"/></td><td>4" 0.068" (1.73mm) 50 ksi (340 MPa)</td></tr> <tr><td><input type="checkbox"/></td><td>5" 0.043" (1.09) 33 ksi (230 MPa)</td></tr> <tr><td><input type="checkbox"/></td><td>Reduced section strap -- fuse = 2.5" wide x 30" long -- ends = 3.75" wide 0.043" (1.09mm) 33 ksi (230 MPa)</td></tr> <tr><td><input type="checkbox"/></td><td>Reduced section strap -- fuse = 2.75" wide x 30" long -- ends = 4.25" wide 0.054" (1.37mm) 50 ksi (340 MPa)</td></tr> <tr><td><input type="checkbox"/></td><td>Reduced section strap -- fuse = 4" wide x 30" long -- ends = 6" wide 0.068" (1.73mm) 50 ksi (340 MPa)</td></tr> <tr><td><input type="checkbox"/></td><td>Reduced section strap -- fuse = 2.5" wide x 60" long -- ends = 3.75" wide 0.043" (1.09mm) 33 ksi (230 MPa)</td></tr> <tr><td><input type="checkbox"/></td><td>Reduced section strap -- fuse = 4" wide x 60" long -- ends = 6" wide 0.068" (1.73mm) 50 ksi (340 MPa)</td></tr> </table>							<input type="checkbox"/>	2.5" 0.043" (1.09mm) 33 ksi (230 MPa)	<input type="checkbox"/>	2.75" 0.054" (1.37mm) 50 ksi (340 MPa)	<input checked="" type="checkbox"/>	4" 0.068" (1.73mm) 50 ksi (340 MPa)	<input type="checkbox"/>	5" 0.043" (1.09) 33 ksi (230 MPa)	<input type="checkbox"/>	Reduced section strap -- fuse = 2.5" wide x 30" long -- ends = 3.75" wide 0.043" (1.09mm) 33 ksi (230 MPa)	<input type="checkbox"/>	Reduced section strap -- fuse = 2.75" wide x 30" long -- ends = 4.25" wide 0.054" (1.37mm) 50 ksi (340 MPa)	<input type="checkbox"/>	Reduced section strap -- fuse = 4" wide x 30" long -- ends = 6" wide 0.068" (1.73mm) 50 ksi (340 MPa)	<input type="checkbox"/>	Reduced section strap -- fuse = 2.5" wide x 60" long -- ends = 3.75" wide 0.043" (1.09mm) 33 ksi (230 MPa)	<input type="checkbox"/>	Reduced section strap -- fuse = 4" wide x 60" long -- ends = 6" wide 0.068" (1.73mm) 50 ksi (340 MPa)																															
<input type="checkbox"/>	2.5" 0.043" (1.09mm) 33 ksi (230 MPa)																																																							
<input type="checkbox"/>	2.75" 0.054" (1.37mm) 50 ksi (340 MPa)																																																							
<input checked="" type="checkbox"/>	4" 0.068" (1.73mm) 50 ksi (340 MPa)																																																							
<input type="checkbox"/>	5" 0.043" (1.09) 33 ksi (230 MPa)																																																							
<input type="checkbox"/>	Reduced section strap -- fuse = 2.5" wide x 30" long -- ends = 3.75" wide 0.043" (1.09mm) 33 ksi (230 MPa)																																																							
<input type="checkbox"/>	Reduced section strap -- fuse = 2.75" wide x 30" long -- ends = 4.25" wide 0.054" (1.37mm) 50 ksi (340 MPa)																																																							
<input type="checkbox"/>	Reduced section strap -- fuse = 4" wide x 30" long -- ends = 6" wide 0.068" (1.73mm) 50 ksi (340 MPa)																																																							
<input type="checkbox"/>	Reduced section strap -- fuse = 2.5" wide x 60" long -- ends = 3.75" wide 0.043" (1.09mm) 33 ksi (230 MPa)																																																							
<input type="checkbox"/>	Reduced section strap -- fuse = 4" wide x 60" long -- ends = 6" wide 0.068" (1.73mm) 50 ksi (340 MPa)																																																							
INTERIOR STUDS:	<input type="checkbox"/> 3-5/8"Wx1-5/8"Fx1/2"Lip 0.043" (1.09mm) 33ksi (230 Mpa) <input checked="" type="checkbox"/> 6"Wx1-5/8"Fx1/2"Lip 0.043" (1.09mm) 33ksi (230 Mpa)		STUD SPACING:	<input checked="" type="checkbox"/> 16" O.C. Other: _____																																																				
BACK-TO-BACK CHORD STUDS:	<input type="checkbox"/> 3-5/8"Wx1-5/8"Fx1/2"Lip 0.043" (1.09mm) 33ksi (230 Mpa) <input type="checkbox"/> 6"Wx1-5/8"Fx1/2"Lip 0.054" (1.37mm) 50ksi (345 Mpa) <input checked="" type="checkbox"/> 6"Wx1-5/8"Fx1/2"Lip 0.068" (1.73mm) 50ksi (345 Mpa)																																																							
CONNECTIONS:	<table border="0" style="width:100%;"> <tr><td>Straps:</td><td><input checked="" type="checkbox"/></td><td>No.10 gauge 0.75" self-drilling wafer head (mod. Truss) Phillips drive</td></tr> <tr><td>Framing:</td><td><input checked="" type="checkbox"/></td><td>No.8 gauge 0.5" self-drilling wafer head (mod. Truss) Phillips drive</td></tr> <tr><td>Hold downs:</td><td><input checked="" type="checkbox"/></td><td>No.14 gauge 1" self-drilling Hex washer head</td></tr> <tr><td>Back-to-Back:</td><td><input checked="" type="checkbox"/></td><td>No.14 gauge 1" self-drilling Hex washer head</td></tr> <tr><td>Chord Studs:</td><td><input checked="" type="checkbox"/></td><td>No.10 gauge 0.75" self-drilling Hex washer head</td></tr> <tr><td>Anchor Rods:</td><td><input type="checkbox"/></td><td>7/8" A307</td></tr> <tr><td></td><td><input checked="" type="checkbox"/></td><td>1" Rod</td></tr> <tr><td>Loading Beam:</td><td><input checked="" type="checkbox"/></td><td>A325 3/4" bolts</td></tr> <tr><td>Base:</td><td><input checked="" type="checkbox"/></td><td>A325 3/4" bolts</td></tr> </table>							Straps:	<input checked="" type="checkbox"/>	No.10 gauge 0.75" self-drilling wafer head (mod. Truss) Phillips drive	Framing:	<input checked="" type="checkbox"/>	No.8 gauge 0.5" self-drilling wafer head (mod. Truss) Phillips drive	Hold downs:	<input checked="" type="checkbox"/>	No.14 gauge 1" self-drilling Hex washer head	Back-to-Back:	<input checked="" type="checkbox"/>	No.14 gauge 1" self-drilling Hex washer head	Chord Studs:	<input checked="" type="checkbox"/>	No.10 gauge 0.75" self-drilling Hex washer head	Anchor Rods:	<input type="checkbox"/>	7/8" A307		<input checked="" type="checkbox"/>	1" Rod	Loading Beam:	<input checked="" type="checkbox"/>	A325 3/4" bolts	Base:	<input checked="" type="checkbox"/>	A325 3/4" bolts																						
Straps:	<input checked="" type="checkbox"/>	No.10 gauge 0.75" self-drilling wafer head (mod. Truss) Phillips drive																																																						
Framing:	<input checked="" type="checkbox"/>	No.8 gauge 0.5" self-drilling wafer head (mod. Truss) Phillips drive																																																						
Hold downs:	<input checked="" type="checkbox"/>	No.14 gauge 1" self-drilling Hex washer head																																																						
Back-to-Back:	<input checked="" type="checkbox"/>	No.14 gauge 1" self-drilling Hex washer head																																																						
Chord Studs:	<input checked="" type="checkbox"/>	No.10 gauge 0.75" self-drilling Hex washer head																																																						
Anchor Rods:	<input type="checkbox"/>	7/8" A307																																																						
	<input checked="" type="checkbox"/>	1" Rod																																																						
Loading Beam:	<input checked="" type="checkbox"/>	A325 3/4" bolts																																																						
Base:	<input checked="" type="checkbox"/>	A325 3/4" bolts																																																						
TRACK:	<input type="checkbox"/> Regular <input type="checkbox"/> Extended <input checked="" type="checkbox"/> Reinforced		<input checked="" type="checkbox"/> 6" web <input type="checkbox"/> 3 5/8" web <input type="checkbox"/> 1-1/4" flange		<input type="checkbox"/> 0.043" (1.09mm) 33ksi (230 Mpa) <input type="checkbox"/> 0.054" (1.37mm) 50ksi (345 Mpa) <input checked="" type="checkbox"/> 0.068" (1.73mm) 50ksi (345 Mpa)																																																			
HOLD DOWNS:	<table border="0" style="width:100%;"> <tr><td><input type="checkbox"/></td><td>S/HD10S Simpson</td><td></td><td></td><td></td><td></td><td></td></tr> <tr><td><input type="checkbox"/></td><td>Fabricated U-shape</td><td></td><td></td><td></td><td></td><td></td></tr> <tr><td><input type="checkbox"/></td><td>6" x 6" 0.054" (1.37mm) 50 ksi (340 MPa) Gusset Plate w/ S/HD15S Simpson</td><td></td><td></td><td></td><td></td><td></td></tr> <tr><td><input type="checkbox"/></td><td>7" x 9" 0.054" (1.37mm) 50 ksi (340 MPa) Gusset Plate w/ S/HD15S Simpson</td><td></td><td></td><td></td><td></td><td></td></tr> <tr><td><input type="checkbox"/></td><td>8" x 8" 0.068" (1.73mm) 50 ksi (340 MPa) Gusset Plate w/ S/HD15S Simpson</td><td></td><td></td><td></td><td></td><td></td></tr> <tr><td><input checked="" type="checkbox"/></td><td>8.5" x 10" 0.068" (1.73mm) 50 ksi (340 MPa) Gusset Plate w/ S/HD15S Simpson</td><td></td><td></td><td></td><td></td><td></td></tr> <tr><td><input type="checkbox"/></td><td>10" x 10" 0.054" (1.37mm) 50 ksi (340 MPa) Gusset Plate w/ S/HD15S Simpson</td><td></td><td></td><td></td><td></td><td></td></tr> </table>							<input type="checkbox"/>	S/HD10S Simpson						<input type="checkbox"/>	Fabricated U-shape						<input type="checkbox"/>	6" x 6" 0.054" (1.37mm) 50 ksi (340 MPa) Gusset Plate w/ S/HD15S Simpson						<input type="checkbox"/>	7" x 9" 0.054" (1.37mm) 50 ksi (340 MPa) Gusset Plate w/ S/HD15S Simpson						<input type="checkbox"/>	8" x 8" 0.068" (1.73mm) 50 ksi (340 MPa) Gusset Plate w/ S/HD15S Simpson						<input checked="" type="checkbox"/>	8.5" x 10" 0.068" (1.73mm) 50 ksi (340 MPa) Gusset Plate w/ S/HD15S Simpson						<input type="checkbox"/>	10" x 10" 0.054" (1.37mm) 50 ksi (340 MPa) Gusset Plate w/ S/HD15S Simpson					
<input type="checkbox"/>	S/HD10S Simpson																																																							
<input type="checkbox"/>	Fabricated U-shape																																																							
<input type="checkbox"/>	6" x 6" 0.054" (1.37mm) 50 ksi (340 MPa) Gusset Plate w/ S/HD15S Simpson																																																							
<input type="checkbox"/>	7" x 9" 0.054" (1.37mm) 50 ksi (340 MPa) Gusset Plate w/ S/HD15S Simpson																																																							
<input type="checkbox"/>	8" x 8" 0.068" (1.73mm) 50 ksi (340 MPa) Gusset Plate w/ S/HD15S Simpson																																																							
<input checked="" type="checkbox"/>	8.5" x 10" 0.068" (1.73mm) 50 ksi (340 MPa) Gusset Plate w/ S/HD15S Simpson																																																							
<input type="checkbox"/>	10" x 10" 0.054" (1.37mm) 50 ksi (340 MPa) Gusset Plate w/ S/HD15S Simpson																																																							
TEST PROTOCOL AND DESCRIPTION:	<input checked="" type="checkbox"/> Monotonic (Rate of Loading 2.5 mm/min) <input type="checkbox"/> Cyclic (CUREE cyclic protocol)																																																							
LVDT MEASUREMENTS:	<input checked="" type="checkbox"/> Actuator LVDT <input checked="" type="checkbox"/> North Slip <input checked="" type="checkbox"/> South Slip		<input checked="" type="checkbox"/> North Uplift <input checked="" type="checkbox"/> South Uplift <input checked="" type="checkbox"/> Top of Wall		TOTAL: <input type="text" value="6"/>																																																			
STRAP WIDTH BEFORE TEST:	<table border="0" style="width:100%;"> <tr> <td style="text-align: center;">Front Right</td> <td style="text-align: center;">Front Left, mm</td> <td style="text-align: center;">Back Right, mm</td> <td style="text-align: center;">Back Left, mm</td> </tr> <tr> <td style="text-align: center;"><input type="text"/></td> <td style="text-align: center;"><input type="text" value="102.85"/></td> <td style="text-align: center;"><input type="text" value="100.73"/></td> <td style="text-align: center;"><input type="text"/></td> </tr> <tr> <td style="text-align: center;"><input type="text"/></td> <td style="text-align: center;"><input type="text" value="102.45"/></td> <td style="text-align: center;"><input type="text" value="100.65"/></td> <td style="text-align: center;"><input type="text"/></td> </tr> <tr> <td style="text-align: center;"><input type="text"/></td> <td style="text-align: center;"><input type="text" value="102.28"/></td> <td style="text-align: center;"><input type="text" value="101.92"/></td> <td style="text-align: center;"><input type="text"/></td> </tr> <tr> <td style="text-align: center;">AVG</td> <td style="text-align: center;"><input type="text" value="0.00"/></td> <td style="text-align: center;">AVG</td> <td style="text-align: center;"><input type="text" value="102.53 mm"/></td> </tr> <tr> <td></td> <td></td> <td style="text-align: center;">AVG</td> <td style="text-align: center;"><input type="text" value="101.10 mm"/></td> </tr> <tr> <td></td> <td></td> <td></td> <td style="text-align: center;">AVG</td> <td style="text-align: center;"><input type="text" value="0.00 mm"/></td> </tr> </table>							Front Right	Front Left, mm	Back Right, mm	Back Left, mm	<input type="text"/>	<input type="text" value="102.85"/>	<input type="text" value="100.73"/>	<input type="text"/>	<input type="text"/>	<input type="text" value="102.45"/>	<input type="text" value="100.65"/>	<input type="text"/>	<input type="text"/>	<input type="text" value="102.28"/>	<input type="text" value="101.92"/>	<input type="text"/>	AVG	<input type="text" value="0.00"/>	AVG	<input type="text" value="102.53 mm"/>			AVG	<input type="text" value="101.10 mm"/>				AVG	<input type="text" value="0.00 mm"/>																				
Front Right	Front Left, mm	Back Right, mm	Back Left, mm																																																					
<input type="text"/>	<input type="text" value="102.85"/>	<input type="text" value="100.73"/>	<input type="text"/>																																																					
<input type="text"/>	<input type="text" value="102.45"/>	<input type="text" value="100.65"/>	<input type="text"/>																																																					
<input type="text"/>	<input type="text" value="102.28"/>	<input type="text" value="101.92"/>	<input type="text"/>																																																					
AVG	<input type="text" value="0.00"/>	AVG	<input type="text" value="102.53 mm"/>																																																					
		AVG	<input type="text" value="101.10 mm"/>																																																					
			AVG	<input type="text" value="0.00 mm"/>																																																				
DATA ACQ. RECORD RATE:	1 scan/sec		MONITOR RATE:	10 scan/sec																																																				
COMMENTS:	-Shear anchors torqued for 10 s with impact wrench -Hold down anchors 1/2 turn from finger tight (load cells used on both hold-downs) -Ambient temperature 29 C -Double chord studs used screwed back to back -Square plate washers (2.5"x2.5") used in all top track connections -Regular washers used in all bottom track connections																																																							

Figure C. 22 Data sheet for test 45 A-M

Cold Formed Steel Strap Braced Walls																																																								
McGill University, Montreal																																																								
TEST:	46 A-C																																																							
RESEARCHER:	Kostadin Velchev	ASSISTANTS:	Gilles Comeau, Nisreen Balh																																																					
DATE:	3-Aug-07		TIME:	9:22																																																				
DIMENSIONS OF WA	8 FT X	8 FT X	6 IN.	INITIAL STRAP SURVEY:	Front Back	Right tight loose	Left loose tight																																																	
STRAP FASTENER CONFIGURATION:				MFR:	McGill																																																			
STRAP SIZE:	<table border="0" style="width:100%;"> <tr><td><input type="checkbox"/></td><td>2.5" 0.043" (1.09mm) 33 ksi (230 MPa)</td></tr> <tr><td><input type="checkbox"/></td><td>2.75" 0.054" (1.37mm) 50 ksi (340 MPa)</td></tr> <tr><td><input checked="" type="checkbox"/></td><td>4" 0.068" (1.73mm) 50 ksi (340 MPa)</td></tr> <tr><td><input type="checkbox"/></td><td>5" 0.043" (1.09) 33 ksi (230 MPa)</td></tr> <tr><td><input type="checkbox"/></td><td>Reduced section strap -- fuse = 2.5" wide x 30" long -- ends = 3.75" wide 0.043" (1.09mm) 33 ksi (230 MPa)</td></tr> <tr><td><input type="checkbox"/></td><td>Reduced section strap -- fuse = 2.75" wide x 30" long -- ends = 4.25" wide 0.054" (1.37mm) 50 ksi (340 MPa)</td></tr> <tr><td><input type="checkbox"/></td><td>Reduced section strap -- fuse = 4" wide x 30" long -- ends = 6" wide 0.068" (1.73mm) 50 ksi (340 MPa)</td></tr> <tr><td><input type="checkbox"/></td><td>Reduced section strap -- fuse = 2.5" wide x 60" long -- ends = 3.75" wide 0.043" (1.09mm) 33 ksi (230 MPa)</td></tr> <tr><td><input type="checkbox"/></td><td>Reduced section strap -- fuse = 4" wide x 60" long -- ends = 6" wide 0.068" (1.73mm) 50 ksi (340 MPa)</td></tr> </table>							<input type="checkbox"/>	2.5" 0.043" (1.09mm) 33 ksi (230 MPa)	<input type="checkbox"/>	2.75" 0.054" (1.37mm) 50 ksi (340 MPa)	<input checked="" type="checkbox"/>	4" 0.068" (1.73mm) 50 ksi (340 MPa)	<input type="checkbox"/>	5" 0.043" (1.09) 33 ksi (230 MPa)	<input type="checkbox"/>	Reduced section strap -- fuse = 2.5" wide x 30" long -- ends = 3.75" wide 0.043" (1.09mm) 33 ksi (230 MPa)	<input type="checkbox"/>	Reduced section strap -- fuse = 2.75" wide x 30" long -- ends = 4.25" wide 0.054" (1.37mm) 50 ksi (340 MPa)	<input type="checkbox"/>	Reduced section strap -- fuse = 4" wide x 30" long -- ends = 6" wide 0.068" (1.73mm) 50 ksi (340 MPa)	<input type="checkbox"/>	Reduced section strap -- fuse = 2.5" wide x 60" long -- ends = 3.75" wide 0.043" (1.09mm) 33 ksi (230 MPa)	<input type="checkbox"/>	Reduced section strap -- fuse = 4" wide x 60" long -- ends = 6" wide 0.068" (1.73mm) 50 ksi (340 MPa)																															
<input type="checkbox"/>	2.5" 0.043" (1.09mm) 33 ksi (230 MPa)																																																							
<input type="checkbox"/>	2.75" 0.054" (1.37mm) 50 ksi (340 MPa)																																																							
<input checked="" type="checkbox"/>	4" 0.068" (1.73mm) 50 ksi (340 MPa)																																																							
<input type="checkbox"/>	5" 0.043" (1.09) 33 ksi (230 MPa)																																																							
<input type="checkbox"/>	Reduced section strap -- fuse = 2.5" wide x 30" long -- ends = 3.75" wide 0.043" (1.09mm) 33 ksi (230 MPa)																																																							
<input type="checkbox"/>	Reduced section strap -- fuse = 2.75" wide x 30" long -- ends = 4.25" wide 0.054" (1.37mm) 50 ksi (340 MPa)																																																							
<input type="checkbox"/>	Reduced section strap -- fuse = 4" wide x 30" long -- ends = 6" wide 0.068" (1.73mm) 50 ksi (340 MPa)																																																							
<input type="checkbox"/>	Reduced section strap -- fuse = 2.5" wide x 60" long -- ends = 3.75" wide 0.043" (1.09mm) 33 ksi (230 MPa)																																																							
<input type="checkbox"/>	Reduced section strap -- fuse = 4" wide x 60" long -- ends = 6" wide 0.068" (1.73mm) 50 ksi (340 MPa)																																																							
INTERIOR STUDS:	<input type="checkbox"/> 3-5/8"Wx1-5/8"Fx1/2"Lip 0.043" (1.09mm) 33ksi (230 MPa) <input checked="" type="checkbox"/> 6"Wx1-5/8"Fx1/2"Lip 0.043" (1.09mm) 33ksi (230 MPa)		STUD SPACING:	<input checked="" type="checkbox"/> 16" O.C. Other : _____																																																				
BACK-TO-BACK CHORD STUDS:	<input type="checkbox"/> 3-5/8"Wx1-5/8"Fx1/2"Lip 0.043" (1.09mm) 33ksi (230 MPa) <input type="checkbox"/> 6"Wx1-5/8"Fx1/2"Lip 0.054" (1.37mm) 50ksi (345 Mpa) <input checked="" type="checkbox"/> 6"Wx1-5/8"Fx1/2"Lip 0.068" (1.73mm) 50ksi (345 Mpa)																																																							
CONNECTIONS:	<table border="0" style="width:100%;"> <tr><td>Straps</td><td><input checked="" type="checkbox"/></td><td>No.10 gauge 0.75" self-drilling wafer head (mod. Truss) Phillips drive</td></tr> <tr><td>Framing</td><td><input checked="" type="checkbox"/></td><td>No.8 gauge 0.5" self-drilling wafer head (mod. Truss) Phillips drive</td></tr> <tr><td>Hold downs:</td><td><input checked="" type="checkbox"/></td><td>No.14 gauge 1" self-drilling Hex washer head</td></tr> <tr><td>Back-to-Back</td><td></td><td></td></tr> <tr><td>Chord Studs:</td><td><input checked="" type="checkbox"/></td><td>No.10 gauge 0.75" self-drilling Hex washer head</td></tr> <tr><td>Anchor Rods</td><td><input type="checkbox"/></td><td>7/8" A307</td></tr> <tr><td></td><td><input checked="" type="checkbox"/></td><td>1" Rod</td></tr> <tr><td>Loading Beam:</td><td><input checked="" type="checkbox"/></td><td>A325 3/4" bolts</td></tr> <tr><td>Base</td><td><input checked="" type="checkbox"/></td><td>A325 3/4" bolts</td></tr> </table>							Straps	<input checked="" type="checkbox"/>	No.10 gauge 0.75" self-drilling wafer head (mod. Truss) Phillips drive	Framing	<input checked="" type="checkbox"/>	No.8 gauge 0.5" self-drilling wafer head (mod. Truss) Phillips drive	Hold downs:	<input checked="" type="checkbox"/>	No.14 gauge 1" self-drilling Hex washer head	Back-to-Back			Chord Studs:	<input checked="" type="checkbox"/>	No.10 gauge 0.75" self-drilling Hex washer head	Anchor Rods	<input type="checkbox"/>	7/8" A307		<input checked="" type="checkbox"/>	1" Rod	Loading Beam:	<input checked="" type="checkbox"/>	A325 3/4" bolts	Base	<input checked="" type="checkbox"/>	A325 3/4" bolts																						
Straps	<input checked="" type="checkbox"/>	No.10 gauge 0.75" self-drilling wafer head (mod. Truss) Phillips drive																																																						
Framing	<input checked="" type="checkbox"/>	No.8 gauge 0.5" self-drilling wafer head (mod. Truss) Phillips drive																																																						
Hold downs:	<input checked="" type="checkbox"/>	No.14 gauge 1" self-drilling Hex washer head																																																						
Back-to-Back																																																								
Chord Studs:	<input checked="" type="checkbox"/>	No.10 gauge 0.75" self-drilling Hex washer head																																																						
Anchor Rods	<input type="checkbox"/>	7/8" A307																																																						
	<input checked="" type="checkbox"/>	1" Rod																																																						
Loading Beam:	<input checked="" type="checkbox"/>	A325 3/4" bolts																																																						
Base	<input checked="" type="checkbox"/>	A325 3/4" bolts																																																						
TRACK:	<input type="checkbox"/> Regular <input checked="" type="checkbox"/> Extended <input type="checkbox"/> Reinforced		<input checked="" type="checkbox"/> 6" web <input type="checkbox"/> 3 5/8" web <input type="checkbox"/> 1-1/4" flange	<input type="checkbox"/> 0.043" (1.09mm) 33ksi (230 MPa) <input type="checkbox"/> 0.054" (1.37mm) 50ksi (345 Mpa) <input checked="" type="checkbox"/> 0.068" (1.73mm) 50ksi (345 Mpa)	10 bolts <input checked="" type="checkbox"/>	6 bolts <input checked="" type="checkbox"/>	2 Anchor Rods <input checked="" type="checkbox"/>																																																	
HOLD DOWNS:	<table border="0" style="width:100%;"> <tr><td><input type="checkbox"/></td><td>S/HD10S Simpson</td><td></td><td></td><td></td><td></td><td></td></tr> <tr><td><input type="checkbox"/></td><td>Fabricated U-shape</td><td></td><td></td><td></td><td></td><td></td></tr> <tr><td><input type="checkbox"/></td><td>6" x 6" 0.054" (1.37mm) 50 ksi (340 MPa) Gusset Plate w/ S/HD15S Simpson</td><td></td><td></td><td></td><td></td><td></td></tr> <tr><td><input type="checkbox"/></td><td>7" x 9" 0.054" (1.37mm) 50 ksi (340 MPa) Gusset Plate w/ S/HD15S Simpson</td><td></td><td></td><td></td><td></td><td></td></tr> <tr><td><input type="checkbox"/></td><td>8" x 8" 0.068" (1.73mm) 50 ksi (340 MPa) Gusset Plate w/ S/HD15S Simpson</td><td></td><td></td><td></td><td></td><td></td></tr> <tr><td><input checked="" type="checkbox"/></td><td>8.5" x 10" 0.068" (1.73mm) 50 ksi (340 MPa) Gusset Plate w/ S/HD15S Simpson</td><td></td><td></td><td></td><td></td><td></td></tr> <tr><td><input type="checkbox"/></td><td>10" x 10" 0.054" (1.37mm) 50 ksi (340 MPa) Gusset Plate w/ S/HD15S Simpson</td><td></td><td></td><td></td><td></td><td></td></tr> </table>							<input type="checkbox"/>	S/HD10S Simpson						<input type="checkbox"/>	Fabricated U-shape						<input type="checkbox"/>	6" x 6" 0.054" (1.37mm) 50 ksi (340 MPa) Gusset Plate w/ S/HD15S Simpson						<input type="checkbox"/>	7" x 9" 0.054" (1.37mm) 50 ksi (340 MPa) Gusset Plate w/ S/HD15S Simpson						<input type="checkbox"/>	8" x 8" 0.068" (1.73mm) 50 ksi (340 MPa) Gusset Plate w/ S/HD15S Simpson						<input checked="" type="checkbox"/>	8.5" x 10" 0.068" (1.73mm) 50 ksi (340 MPa) Gusset Plate w/ S/HD15S Simpson						<input type="checkbox"/>	10" x 10" 0.054" (1.37mm) 50 ksi (340 MPa) Gusset Plate w/ S/HD15S Simpson					
<input type="checkbox"/>	S/HD10S Simpson																																																							
<input type="checkbox"/>	Fabricated U-shape																																																							
<input type="checkbox"/>	6" x 6" 0.054" (1.37mm) 50 ksi (340 MPa) Gusset Plate w/ S/HD15S Simpson																																																							
<input type="checkbox"/>	7" x 9" 0.054" (1.37mm) 50 ksi (340 MPa) Gusset Plate w/ S/HD15S Simpson																																																							
<input type="checkbox"/>	8" x 8" 0.068" (1.73mm) 50 ksi (340 MPa) Gusset Plate w/ S/HD15S Simpson																																																							
<input checked="" type="checkbox"/>	8.5" x 10" 0.068" (1.73mm) 50 ksi (340 MPa) Gusset Plate w/ S/HD15S Simpson																																																							
<input type="checkbox"/>	10" x 10" 0.054" (1.37mm) 50 ksi (340 MPa) Gusset Plate w/ S/HD15S Simpson																																																							
TEST PROTOCOL AND DESCRIPTION:	<input type="checkbox"/> Monotonic (Rate of Loading 2.5 mm/min) <input checked="" type="checkbox"/> Cyclic (CUREE cyclic protocol)																																																							
LVDT MEASUREMENTS:	<input checked="" type="checkbox"/> Actuator LVDT <input checked="" type="checkbox"/> North Slip <input checked="" type="checkbox"/> South Slip		<input checked="" type="checkbox"/> North Uplift <input checked="" type="checkbox"/> South Uplift <input checked="" type="checkbox"/> Top of Wall		TOTAL: <input type="text" value="6"/>																																																			
STRAP WIDTH BEFORE TEST:	<table border="1" style="width:100%; text-align: center;"> <tr> <td>Front Right</td> <td>102.31</td> <td>Front Left, mm</td> <td>101.56</td> <td>Back Right, mm</td> <td>102.08</td> <td>Back Left, mm</td> <td>102.73</td> </tr> <tr> <td></td> <td>102.45</td> <td></td> <td>101.06</td> <td></td> <td>102.48</td> <td></td> <td>102.35</td> </tr> <tr> <td></td> <td>102.64</td> <td></td> <td>101.33</td> <td></td> <td>102.62</td> <td></td> <td>102.25</td> </tr> <tr> <td>AVG</td> <td>102.47</td> <td>AVG</td> <td>101.32 mm</td> <td>AVG</td> <td>102.39 mm</td> <td>AVG</td> <td>102.44 mm</td> </tr> </table>							Front Right	102.31	Front Left, mm	101.56	Back Right, mm	102.08	Back Left, mm	102.73		102.45		101.06		102.48		102.35		102.64		101.33		102.62		102.25	AVG	102.47	AVG	101.32 mm	AVG	102.39 mm	AVG	102.44 mm																	
Front Right	102.31	Front Left, mm	101.56	Back Right, mm	102.08	Back Left, mm	102.73																																																	
	102.45		101.06		102.48		102.35																																																	
	102.64		101.33		102.62		102.25																																																	
AVG	102.47	AVG	101.32 mm	AVG	102.39 mm	AVG	102.44 mm																																																	
DATA ACQ. RECORD RATE:	100 scan/sec			MONITOR RATE:	100 scan/sec																																																			
COMMENTS:	-Shear anchors torqued for 10 s with impact wrench -Hold down anchors 1/2 turn from finger tight (load cells used on both hold-downs) -Ambient temperature 31 C -Double chord studs used screwed back to back -Square plate washers (2.5"x2.5") used in all top track connections -Regular washers used in all bottom track connections																																																							

Figure C. 23 Data sheet for test 46 A-C

Cold Formed Steel Strap Braced Walls
McGill University, Montreal

TEST: 47A-M

RESEARCHER: Kostadin Velchev ASSISTANTS: Gilles Comeau, Nisreen Balh

DATE: 28-May-07 TIME: 9:25

DIMENSIONS OF WALL: 8 FT X 8 FT X 6 IN. INITIAL STRAP SURVEY: Front Right Left
Back Tight Tight

STRAP FASTENER CONFIGURATION: MFR: McGill

STRAP SIZE:

<input type="checkbox"/>	2.5" 0.043" (1.09mm) 33 ksi (230 MPa)
<input checked="" type="checkbox"/>	2.75" 0.054" (1.37mm) 50 ksi (340 MPa)
<input type="checkbox"/>	4" 0.068" (1.73mm) 50 ksi (340 MPa)
<input type="checkbox"/>	5" 0.043" (1.09) 33 ksi (230 MPa)
<input type="checkbox"/>	Reduced section strap -- fuse = 2.5" wide x 30" long -- ends = 3.75" wide 0.043" (1.09mm) 33 ksi (230 MPa)
<input type="checkbox"/>	Reduced section strap -- fuse = 2.75" wide x 30" long -- ends = 4.25" wide 0.054" (1.37mm) 50 ksi (340 MPa)
<input type="checkbox"/>	Reduced section strap -- fuse = 4" wide x 30" long -- ends = 6" wide 0.068" (1.73mm) 50 ksi (340 MPa)
<input type="checkbox"/>	Reduced section strap -- fuse = 2.5" wide x 60" long -- ends = 3.75" wide 0.043" (1.09mm) 33 ksi (230 MPa)
<input type="checkbox"/>	Reduced section strap -- fuse = 4" wide x 60" long -- ends = 6" wide 0.068" (1.73mm) 50 ksi (340 MPa)

INTERIOR STUDS:

<input type="checkbox"/>	3-5/8"Wx1-5/8"Fx1/2"Lip 0.043" (1.09mm) 33ksi (230 Mpa)
<input checked="" type="checkbox"/>	6"Wx1-5/8"Fx1/2"Lip 0.043" (1.09mm) 33ksi (230 Mpa)

STUD SPACING: 16" O.C. Other: _____

BACK-TO-BACK CHORD STUDS:

<input type="checkbox"/>	3-5/8"Wx1-5/8"Fx1/2"Lip 0.043" (1.09mm) 33ksi (230 Mpa)
<input checked="" type="checkbox"/>	6"Wx1-5/8"Fx1/2"Lip 0.054" (1.37mm) 50ksi (345 Mpa)
<input type="checkbox"/>	6"Wx1-5/8"Fx1/2"Lip 0.068" (1.73mm) 50ksi (345 Mpa)

CONNECTIONS:

Straps	<input checked="" type="checkbox"/>	No.10 gauge 0.75" self-drilling wafer head (mod. Truss) Phillips drive
Framing	<input checked="" type="checkbox"/>	No.8 gauge 0.5" self-drilling wafer head (mod. Truss) Phillips drive
Hold downs	<input checked="" type="checkbox"/>	No.14 gauge 0.1" self-drilling Hex washer head
Back-to-Back	<input checked="" type="checkbox"/>	No.14 gauge 0.1" self-drilling Hex washer head
Chord Studs	<input checked="" type="checkbox"/>	No.10 gauge 0.75" self-drilling Hex washer head
Anchor Rods	<input type="checkbox"/>	7/8" A307 Rod
	<input checked="" type="checkbox"/>	1" A307 Rod
Loading Beam	<input checked="" type="checkbox"/>	A325 3/4" bolts
Base	<input checked="" type="checkbox"/>	A325 3/4" bolts

10 bolts 2 Anchor Rods
6 bolts 2 Anchor Rods

TRACK:

<input type="checkbox"/>	Regular	<input checked="" type="checkbox"/>	6" web	<input type="checkbox"/>	0.043" (1.09mm) 33ksi (230 Mpa)
<input checked="" type="checkbox"/>	Extended	<input type="checkbox"/>	3 5/8" web	<input checked="" type="checkbox"/>	0.054" (1.37mm) 50ksi (345 Mpa)
<input type="checkbox"/>	Reinforced	<input type="checkbox"/>	1-1/4" flange	<input checked="" type="checkbox"/>	0.068" (1.73mm) 50ksi (345 Mpa)

HOLD DOWNS:

<input type="checkbox"/>	S/HD10S Simpson	inside	outside	raised
<input type="checkbox"/>	Fabricated U-shape			
<input type="checkbox"/>	6" x 6" 0.054" (1.37mm) 50 ksi (340 MPa) Gusset Plate w/ S/HD15SS Simpson			
<input checked="" type="checkbox"/>	7" x 9" 0.054" (1.37mm) 50 ksi (340 MPa) Gusset Plate w/ S/HD15SS Simpson	<input checked="" type="checkbox"/>		
<input type="checkbox"/>	8" x 8" 0.068" (1.73mm) 50 ksi (340 MPa) Gusset Plate w/ S/HD15SS Simpson			
<input type="checkbox"/>	8.5" x 10" 0.068" (1.73mm) 50 ksi (340 MPa) Gusset Plate w/ S/HD15SS Simpson			
<input type="checkbox"/>	10" x 10" 0.054" (1.37mm) 50 ksi (340 MPa) Gusset Plate w/ S/HD15SS Simpson			

TEST PROTOCOL AND DESCRIPTION:

<input checked="" type="checkbox"/>	Monotonic (Rate of Loading 2.5 mm/min)
<input type="checkbox"/>	Cyclic (CUREE cyclic protocol)

LVDT MEASUREMENTS:

<input checked="" type="checkbox"/>	Actuator LVDT	<input checked="" type="checkbox"/>	North Uplift
<input checked="" type="checkbox"/>	North Slip	<input checked="" type="checkbox"/>	South Uplift
<input checked="" type="checkbox"/>	South Slip	<input checked="" type="checkbox"/>	Top of Wall

TOTAL: 6

STRAP WIDTH BEFORE TEST:

Front Right	70.16	Back Right, mm	
	70.10		
	70.80		
AVG		AVG	70.35 mm
		AVG	
		AVG	

DATA ACQ. RECORD RATE: 1 scan/sec MONITOR RATE: 10 scan/sec

COMMENTS:

- Shear anchors torqued for 10 s with impact wrench
- Hold down anchors 1/2 turn from finger tight (load cells used on both hold-downs)
- Double chord studs used screwed back to back
- Square plate washers (2.5"x2.5") used in all top track connections
- Regular washers used in all bottom track connections
- Straps on one side of wall only

Figure C. 24 Data sheet for test 47 A-M

Cold Formed Steel Strap Braced Walls McGill University, Montreal																																												
TEST:	48 A-C																																											
RESEARCHER:	Kostadin Velchev	ASSISTANTS:	Gilles Comeau, Nisreen Balh																																									
DATE:	30-Jul-07	TIME:	12:14																																									
DIMENSIONS OF WALL:	8 FT X	8 FT X	6 IN.																																									
STRAP FASTENER CONFIGURATION:	MFR: McGill																																											
STRAP SIZE:	<table border="1" style="width:100%; border-collapse: collapse;"> <tr><td><input type="checkbox"/></td><td>2.5" 0.043" (1.09mm) 33 ksi (230 MPa)</td></tr> <tr><td><input checked="" type="checkbox"/></td><td>2.75" 0.054" (1.37mm) 50 ksi (340 MPa)</td></tr> <tr><td><input type="checkbox"/></td><td>4" 0.068" (1.73mm) 50 ksi (340 MPa)</td></tr> <tr><td><input type="checkbox"/></td><td>5" 0.043" (1.09) 33 ksi (230 MPa)</td></tr> <tr><td><input type="checkbox"/></td><td>Reduced section strap -- fuse = 2.5" wide x 30" long -- ends = 3.75" wide 0.043" (1.09mm) 33 ksi (230 MPa)</td></tr> <tr><td><input type="checkbox"/></td><td>Reduced section strap -- fuse = 2.75" wide x 30" long -- ends = 4.25" wide 0.054" (1.37mm) 50 ksi (340 MPa)</td></tr> <tr><td><input type="checkbox"/></td><td>Reduced section strap -- fuse = 4" wide x 30" long -- ends = 6" wide 0.068" (1.73mm) 50 ksi (340 MPa)</td></tr> <tr><td><input type="checkbox"/></td><td>Reduced section strap -- fuse = 2.5" wide x 60" long -- ends = 3.75" wide 0.043" (1.09mm) 33 ksi (230 MPa)</td></tr> <tr><td><input type="checkbox"/></td><td>Reduced section strap -- fuse = 4" wide x 60" long -- ends = 6" wide 0.068" (1.73mm) 50 ksi (340 MPa)</td></tr> </table>			<input type="checkbox"/>	2.5" 0.043" (1.09mm) 33 ksi (230 MPa)	<input checked="" type="checkbox"/>	2.75" 0.054" (1.37mm) 50 ksi (340 MPa)	<input type="checkbox"/>	4" 0.068" (1.73mm) 50 ksi (340 MPa)	<input type="checkbox"/>	5" 0.043" (1.09) 33 ksi (230 MPa)	<input type="checkbox"/>	Reduced section strap -- fuse = 2.5" wide x 30" long -- ends = 3.75" wide 0.043" (1.09mm) 33 ksi (230 MPa)	<input type="checkbox"/>	Reduced section strap -- fuse = 2.75" wide x 30" long -- ends = 4.25" wide 0.054" (1.37mm) 50 ksi (340 MPa)	<input type="checkbox"/>	Reduced section strap -- fuse = 4" wide x 30" long -- ends = 6" wide 0.068" (1.73mm) 50 ksi (340 MPa)	<input type="checkbox"/>	Reduced section strap -- fuse = 2.5" wide x 60" long -- ends = 3.75" wide 0.043" (1.09mm) 33 ksi (230 MPa)	<input type="checkbox"/>	Reduced section strap -- fuse = 4" wide x 60" long -- ends = 6" wide 0.068" (1.73mm) 50 ksi (340 MPa)																							
<input type="checkbox"/>	2.5" 0.043" (1.09mm) 33 ksi (230 MPa)																																											
<input checked="" type="checkbox"/>	2.75" 0.054" (1.37mm) 50 ksi (340 MPa)																																											
<input type="checkbox"/>	4" 0.068" (1.73mm) 50 ksi (340 MPa)																																											
<input type="checkbox"/>	5" 0.043" (1.09) 33 ksi (230 MPa)																																											
<input type="checkbox"/>	Reduced section strap -- fuse = 2.5" wide x 30" long -- ends = 3.75" wide 0.043" (1.09mm) 33 ksi (230 MPa)																																											
<input type="checkbox"/>	Reduced section strap -- fuse = 2.75" wide x 30" long -- ends = 4.25" wide 0.054" (1.37mm) 50 ksi (340 MPa)																																											
<input type="checkbox"/>	Reduced section strap -- fuse = 4" wide x 30" long -- ends = 6" wide 0.068" (1.73mm) 50 ksi (340 MPa)																																											
<input type="checkbox"/>	Reduced section strap -- fuse = 2.5" wide x 60" long -- ends = 3.75" wide 0.043" (1.09mm) 33 ksi (230 MPa)																																											
<input type="checkbox"/>	Reduced section strap -- fuse = 4" wide x 60" long -- ends = 6" wide 0.068" (1.73mm) 50 ksi (340 MPa)																																											
INTERIOR STUDS:	<table border="1" style="width:100%; border-collapse: collapse;"> <tr><td><input type="checkbox"/></td><td>3-5/8"Wx1-5/8"Fx1/2"Lip 0.043" (1.09mm) 33ksi (230 Mpa)</td></tr> <tr><td><input checked="" type="checkbox"/></td><td>6"Wx1-5/8"Fx1/2"Lip 0.043" (1.09mm) 33ksi (230 Mpa)</td></tr> </table>	<input type="checkbox"/>	3-5/8"Wx1-5/8"Fx1/2"Lip 0.043" (1.09mm) 33ksi (230 Mpa)	<input checked="" type="checkbox"/>	6"Wx1-5/8"Fx1/2"Lip 0.043" (1.09mm) 33ksi (230 Mpa)	STUD SPACING:	<table border="1" style="width:100%; border-collapse: collapse;"> <tr><td><input checked="" type="checkbox"/></td><td>16" O.C.</td></tr> <tr><td><input type="checkbox"/></td><td>Other : _____</td></tr> </table>	<input checked="" type="checkbox"/>	16" O.C.	<input type="checkbox"/>	Other : _____																																	
<input type="checkbox"/>	3-5/8"Wx1-5/8"Fx1/2"Lip 0.043" (1.09mm) 33ksi (230 Mpa)																																											
<input checked="" type="checkbox"/>	6"Wx1-5/8"Fx1/2"Lip 0.043" (1.09mm) 33ksi (230 Mpa)																																											
<input checked="" type="checkbox"/>	16" O.C.																																											
<input type="checkbox"/>	Other : _____																																											
BACK-TO-BACK CHORD STUDS:	<table border="1" style="width:100%; border-collapse: collapse;"> <tr><td><input type="checkbox"/></td><td>3-5/8"Wx1-5/8"Fx1/2"Lip 0.043" (1.09mm) 33ksi (230 Mpa)</td></tr> <tr><td><input checked="" type="checkbox"/></td><td>6"Wx1-5/8"Fx1/2"Lip 0.054" (1.37mm) 50ksi (345 Mpa)</td></tr> <tr><td><input type="checkbox"/></td><td>6"Wx1-5/8"Fx1/2"Lip 0.068" (1.73mm) 50ksi (345 Mpa)</td></tr> </table>			<input type="checkbox"/>	3-5/8"Wx1-5/8"Fx1/2"Lip 0.043" (1.09mm) 33ksi (230 Mpa)	<input checked="" type="checkbox"/>	6"Wx1-5/8"Fx1/2"Lip 0.054" (1.37mm) 50ksi (345 Mpa)	<input type="checkbox"/>	6"Wx1-5/8"Fx1/2"Lip 0.068" (1.73mm) 50ksi (345 Mpa)																																			
<input type="checkbox"/>	3-5/8"Wx1-5/8"Fx1/2"Lip 0.043" (1.09mm) 33ksi (230 Mpa)																																											
<input checked="" type="checkbox"/>	6"Wx1-5/8"Fx1/2"Lip 0.054" (1.37mm) 50ksi (345 Mpa)																																											
<input type="checkbox"/>	6"Wx1-5/8"Fx1/2"Lip 0.068" (1.73mm) 50ksi (345 Mpa)																																											
CONNECTIONS:	<table border="1" style="width:100%; border-collapse: collapse;"> <tr><td>Straps</td><td><input checked="" type="checkbox"/></td><td>No.10 gauge 0.75" self-drilling wafer head (mod. Truss) Phillips drive</td></tr> <tr><td>Framing:</td><td><input checked="" type="checkbox"/></td><td>No.8 gauge 0.5" self-drilling wafer head (mod. Truss) Phillips drive</td></tr> <tr><td>Hold downs:</td><td><input checked="" type="checkbox"/></td><td>No.14 gauge 0.1" self-drilling Hex washer head</td></tr> <tr><td>Back-to-Back</td><td><input checked="" type="checkbox"/></td><td>No.14 gauge 0.1" self-drilling Hex washer head</td></tr> <tr><td>Chord Studs:</td><td><input checked="" type="checkbox"/></td><td>No.10 gauge 0.75" self-drilling Hex washer head</td></tr> <tr><td>Anchor Rods</td><td><input type="checkbox"/></td><td>7/8" A307 Rod</td></tr> <tr><td></td><td><input checked="" type="checkbox"/></td><td>1" A307 Rod</td></tr> <tr><td>Loading Beam:</td><td><input checked="" type="checkbox"/></td><td>A325 3/4" bolts</td></tr> <tr><td>Base</td><td><input checked="" type="checkbox"/></td><td>A325 3/4" bolts</td></tr> </table>			Straps	<input checked="" type="checkbox"/>	No.10 gauge 0.75" self-drilling wafer head (mod. Truss) Phillips drive	Framing:	<input checked="" type="checkbox"/>	No.8 gauge 0.5" self-drilling wafer head (mod. Truss) Phillips drive	Hold downs:	<input checked="" type="checkbox"/>	No.14 gauge 0.1" self-drilling Hex washer head	Back-to-Back	<input checked="" type="checkbox"/>	No.14 gauge 0.1" self-drilling Hex washer head	Chord Studs:	<input checked="" type="checkbox"/>	No.10 gauge 0.75" self-drilling Hex washer head	Anchor Rods	<input type="checkbox"/>	7/8" A307 Rod		<input checked="" type="checkbox"/>	1" A307 Rod	Loading Beam:	<input checked="" type="checkbox"/>	A325 3/4" bolts	Base	<input checked="" type="checkbox"/>	A325 3/4" bolts														
Straps	<input checked="" type="checkbox"/>	No.10 gauge 0.75" self-drilling wafer head (mod. Truss) Phillips drive																																										
Framing:	<input checked="" type="checkbox"/>	No.8 gauge 0.5" self-drilling wafer head (mod. Truss) Phillips drive																																										
Hold downs:	<input checked="" type="checkbox"/>	No.14 gauge 0.1" self-drilling Hex washer head																																										
Back-to-Back	<input checked="" type="checkbox"/>	No.14 gauge 0.1" self-drilling Hex washer head																																										
Chord Studs:	<input checked="" type="checkbox"/>	No.10 gauge 0.75" self-drilling Hex washer head																																										
Anchor Rods	<input type="checkbox"/>	7/8" A307 Rod																																										
	<input checked="" type="checkbox"/>	1" A307 Rod																																										
Loading Beam:	<input checked="" type="checkbox"/>	A325 3/4" bolts																																										
Base	<input checked="" type="checkbox"/>	A325 3/4" bolts																																										
TRACK:	<table border="1" style="width:100%; border-collapse: collapse;"> <tr><td><input type="checkbox"/></td><td>Regular</td><td><input checked="" type="checkbox"/></td><td>6" web</td></tr> <tr><td><input checked="" type="checkbox"/></td><td>Extended</td><td><input type="checkbox"/></td><td>3 5/8" web</td></tr> <tr><td><input type="checkbox"/></td><td>Reinforced</td><td><input type="checkbox"/></td><td>1-1/4" flange</td></tr> </table>	<input type="checkbox"/>	Regular	<input checked="" type="checkbox"/>	6" web	<input checked="" type="checkbox"/>	Extended	<input type="checkbox"/>	3 5/8" web	<input type="checkbox"/>	Reinforced	<input type="checkbox"/>	1-1/4" flange	<table border="1" style="width:100%; border-collapse: collapse;"> <tr><td><input type="checkbox"/></td><td>0.043" (1.09mm) 33ksi (230 Mpa)</td></tr> <tr><td><input checked="" type="checkbox"/></td><td>0.054" (1.37mm) 50ksi (345 Mpa)</td></tr> <tr><td><input type="checkbox"/></td><td>0.068" (1.73mm) 50ksi (345 Mpa)</td></tr> </table>	<input type="checkbox"/>	0.043" (1.09mm) 33ksi (230 Mpa)	<input checked="" type="checkbox"/>	0.054" (1.37mm) 50ksi (345 Mpa)	<input type="checkbox"/>	0.068" (1.73mm) 50ksi (345 Mpa)	<table border="1" style="width:100%; border-collapse: collapse;"> <tr><td>10 bolts</td><td><input checked="" type="checkbox"/></td><td>2 Anchor Rods</td><td><input checked="" type="checkbox"/></td></tr> <tr><td>6 bolts</td><td><input checked="" type="checkbox"/></td><td>2 Anchor Rods</td><td><input checked="" type="checkbox"/></td></tr> </table>	10 bolts	<input checked="" type="checkbox"/>	2 Anchor Rods	<input checked="" type="checkbox"/>	6 bolts	<input checked="" type="checkbox"/>	2 Anchor Rods	<input checked="" type="checkbox"/>															
<input type="checkbox"/>	Regular	<input checked="" type="checkbox"/>	6" web																																									
<input checked="" type="checkbox"/>	Extended	<input type="checkbox"/>	3 5/8" web																																									
<input type="checkbox"/>	Reinforced	<input type="checkbox"/>	1-1/4" flange																																									
<input type="checkbox"/>	0.043" (1.09mm) 33ksi (230 Mpa)																																											
<input checked="" type="checkbox"/>	0.054" (1.37mm) 50ksi (345 Mpa)																																											
<input type="checkbox"/>	0.068" (1.73mm) 50ksi (345 Mpa)																																											
10 bolts	<input checked="" type="checkbox"/>	2 Anchor Rods	<input checked="" type="checkbox"/>																																									
6 bolts	<input checked="" type="checkbox"/>	2 Anchor Rods	<input checked="" type="checkbox"/>																																									
HOLD DOWNS:	<table border="1" style="width:100%; border-collapse: collapse;"> <tr><td><input type="checkbox"/></td><td>S/HD10S Simpson</td></tr> <tr><td><input type="checkbox"/></td><td>Fabricated U-shape</td></tr> <tr><td><input type="checkbox"/></td><td>6" x 6" 0.054" (1.37mm) 50 ksi (340 MPa) Gusset Plate w/ S/HD15SS Simpson</td></tr> <tr><td><input checked="" type="checkbox"/></td><td>7" x 9" 0.054" (1.37mm) 50 ksi (340 MPa) Gusset Plate w/ S/HD15SS Simpson</td></tr> <tr><td><input type="checkbox"/></td><td>8" x 8" 0.068" (1.73mm) 50 ksi (340 MPa) Gusset Plate w/ S/HD15SS Simpson</td></tr> <tr><td><input type="checkbox"/></td><td>8.5" x 10" 0.068" (1.73mm) 50 ksi (340 MPa) Gusset Plate w/ S/HD15SS Simpson</td></tr> <tr><td><input type="checkbox"/></td><td>10" x 10" 0.054" (1.37mm) 50 ksi (340 MPa) Gusset Plate w/ S/HD15SS Simpson</td></tr> </table>	<input type="checkbox"/>	S/HD10S Simpson	<input type="checkbox"/>	Fabricated U-shape	<input type="checkbox"/>	6" x 6" 0.054" (1.37mm) 50 ksi (340 MPa) Gusset Plate w/ S/HD15SS Simpson	<input checked="" type="checkbox"/>	7" x 9" 0.054" (1.37mm) 50 ksi (340 MPa) Gusset Plate w/ S/HD15SS Simpson	<input type="checkbox"/>	8" x 8" 0.068" (1.73mm) 50 ksi (340 MPa) Gusset Plate w/ S/HD15SS Simpson	<input type="checkbox"/>	8.5" x 10" 0.068" (1.73mm) 50 ksi (340 MPa) Gusset Plate w/ S/HD15SS Simpson	<input type="checkbox"/>	10" x 10" 0.054" (1.37mm) 50 ksi (340 MPa) Gusset Plate w/ S/HD15SS Simpson	<table border="1" style="width:100%; border-collapse: collapse;"> <tr><td></td><td>inside</td><td>outside</td><td>raised</td></tr> <tr><td></td><td></td><td></td><td></td></tr> <tr><td></td><td></td><td></td><td></td></tr> <tr><td></td><td></td><td></td><td></td></tr> <tr><td></td><td></td><td></td><td></td></tr> <tr><td></td><td></td><td></td><td></td></tr> <tr><td></td><td></td><td></td><td></td></tr> </table>		inside	outside	raised																								
<input type="checkbox"/>	S/HD10S Simpson																																											
<input type="checkbox"/>	Fabricated U-shape																																											
<input type="checkbox"/>	6" x 6" 0.054" (1.37mm) 50 ksi (340 MPa) Gusset Plate w/ S/HD15SS Simpson																																											
<input checked="" type="checkbox"/>	7" x 9" 0.054" (1.37mm) 50 ksi (340 MPa) Gusset Plate w/ S/HD15SS Simpson																																											
<input type="checkbox"/>	8" x 8" 0.068" (1.73mm) 50 ksi (340 MPa) Gusset Plate w/ S/HD15SS Simpson																																											
<input type="checkbox"/>	8.5" x 10" 0.068" (1.73mm) 50 ksi (340 MPa) Gusset Plate w/ S/HD15SS Simpson																																											
<input type="checkbox"/>	10" x 10" 0.054" (1.37mm) 50 ksi (340 MPa) Gusset Plate w/ S/HD15SS Simpson																																											
	inside	outside	raised																																									
TEST PROTOCOL AND DESCRIPTION:	<table border="1" style="width:100%; border-collapse: collapse;"> <tr><td><input type="checkbox"/></td><td>Monotonic (Rate of Loading 2.5 mm/min)</td></tr> <tr><td><input checked="" type="checkbox"/></td><td>Cyclic (CUREE cyclic protocol)</td></tr> </table>			<input type="checkbox"/>	Monotonic (Rate of Loading 2.5 mm/min)	<input checked="" type="checkbox"/>	Cyclic (CUREE cyclic protocol)																																					
<input type="checkbox"/>	Monotonic (Rate of Loading 2.5 mm/min)																																											
<input checked="" type="checkbox"/>	Cyclic (CUREE cyclic protocol)																																											
LVDT MEASUREMENTS:	<table border="1" style="width:100%; border-collapse: collapse;"> <tr><td><input checked="" type="checkbox"/></td><td>Actuator LVDT</td></tr> <tr><td><input checked="" type="checkbox"/></td><td>North Slip</td></tr> <tr><td><input checked="" type="checkbox"/></td><td>South Slip</td></tr> </table>	<input checked="" type="checkbox"/>	Actuator LVDT	<input checked="" type="checkbox"/>	North Slip	<input checked="" type="checkbox"/>	South Slip	<table border="1" style="width:100%; border-collapse: collapse;"> <tr><td><input checked="" type="checkbox"/></td><td>North Uplift</td></tr> <tr><td><input checked="" type="checkbox"/></td><td>South Uplift</td></tr> <tr><td><input checked="" type="checkbox"/></td><td>Top of Wall</td></tr> </table>	<input checked="" type="checkbox"/>	North Uplift	<input checked="" type="checkbox"/>	South Uplift	<input checked="" type="checkbox"/>	Top of Wall	TOTAL: <input type="text" value="6"/>																													
<input checked="" type="checkbox"/>	Actuator LVDT																																											
<input checked="" type="checkbox"/>	North Slip																																											
<input checked="" type="checkbox"/>	South Slip																																											
<input checked="" type="checkbox"/>	North Uplift																																											
<input checked="" type="checkbox"/>	South Uplift																																											
<input checked="" type="checkbox"/>	Top of Wall																																											
STRAP WIDTH BEFORE TEST:	<table border="1" style="width:100%; border-collapse: collapse;"> <tr><td>Front Right</td><td>70.16</td></tr> <tr><td></td><td>70.13</td></tr> <tr><td></td><td>70.37</td></tr> <tr><td>AVG</td><td>70.22 mm</td></tr> </table>	Front Right	70.16		70.13		70.37	AVG	70.22 mm	<table border="1" style="width:100%; border-collapse: collapse;"> <tr><td>Front Left, mm</td><td>70.39</td></tr> <tr><td></td><td>70.95</td></tr> <tr><td></td><td>70.12</td></tr> <tr><td>AVG</td><td>70.49 mm</td></tr> </table>	Front Left, mm	70.39		70.95		70.12	AVG	70.49 mm	<table border="1" style="width:100%; border-collapse: collapse;"> <tr><td>Back Right, mm</td><td></td></tr> <tr><td></td><td></td></tr> <tr><td></td><td></td></tr> <tr><td>AVG</td><td> mm</td></tr> </table>	Back Right, mm						AVG	mm	<table border="1" style="width:100%; border-collapse: collapse;"> <tr><td>Back Left, mm</td><td></td></tr> <tr><td></td><td></td></tr> <tr><td></td><td></td></tr> <tr><td>AVG</td><td> mm</td></tr> </table>	Back Left, mm						AVG	mm								
Front Right	70.16																																											
	70.13																																											
	70.37																																											
AVG	70.22 mm																																											
Front Left, mm	70.39																																											
	70.95																																											
	70.12																																											
AVG	70.49 mm																																											
Back Right, mm																																												
AVG	mm																																											
Back Left, mm																																												
AVG	mm																																											
DATA ACQ. RECORD RATE:	100 scan/sec																																											
MONITOR RATE:	100 scan/sec																																											
COMMENTS:	<ul style="list-style-type: none"> -Shear anchors torqued for 10 s with impact wrench -Hold down anchors 1/2 turn from finger tight (load cells used on both hold-downs) -Double chord studs used screwed back to back -Square plate washers (2.5"x2.5") used in all top track connections -Regular washers used in all bottom track connections -Straps on one side of wall only 																																											

Figure C. 25 Data sheet for test 48 A-C

Test name: 9C-M
 Date tested: May 19, 2007
 Wall size: 8x8
 Strip size: 5"
 Extended track: yes no
 Holddown: inside outside
 Test mode: Cyclic Monotonic

Stud flanges curled inward on Far South Stud.

Notes
 ① Drop in load → track compression failure
 ② South WDT fell off. 60mm

Yielding of studs along at least 2/3 of length (Front & Back)
 Web of chord stud pushed in (not bent)
 Bearing failure of track
 Bottom track around anchor rod
 Crushhead
 Screws
 5 front
 5 back

Top track crushed
 Screws - 7 front
 6 back

Load →

SG1
 SG2
 SG3

8'0"
 16"
 16"
 16"
 16"
 16"
 16"
 16"
 8'0"
 N

Snickling of chord stud flanges/lps

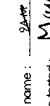

McGill
 Light Gauge Steel Frame Strip Blocked Shear Wall Testing

Figure C. 26 Observations for test 9 C-M



Cold Formed Steel Frame Strap Braced Shear Wall Testing

$F_y = 276 \text{ kN}$ (32W)
 $F_u = 36.5 \text{ kN}$ (2)
 $A_n = 182 \text{ mm}^2$
 $A_g = 222 \text{ mm}^2$

position of steel bracing is different

9.5.24

Test name : 25A-M-1
 Date tested : June 22, 2007 July 4
 Wall Size : 9' x 8'
 Strap Size : 2.5"
 Extended Track : yes no
 Holddown : Inside Outside Raised
 Test mode : Cyclic Monotonic

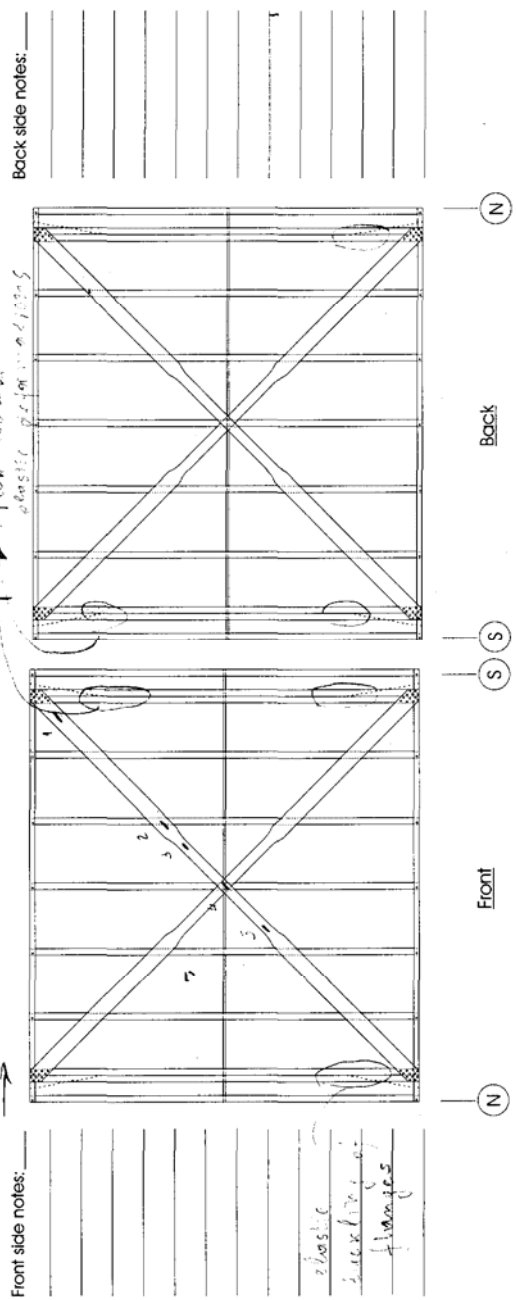

Front side notes:

Back side notes:

elastic
 buckle
 hinges

General notes:

bracing yield about \rightarrow more than 150 mm

braces yielded but none of them was broken.

Figure C. 27 Observations for test 25 A-M 1



Cold Formed Steel Frame Strap Braced Shear Wall Testing

5 screws were added

Test name: 25A-M-2
 Date tested: July 3, 2007
 Wall Size: 9'x8'
 Strap Size: 2.5"
 Extended Track: yes no
 Holddown: Inside Outside Raised
 Test mode: Cyclic Monotonic

test $F_y = 21.5 \text{ kN}$
 (32 kN)
 $F_u = 36.5 \text{ kN}$
 $\Delta u = 183 \text{ mm}$
 $\Delta m \times = 323 \text{ mm}$

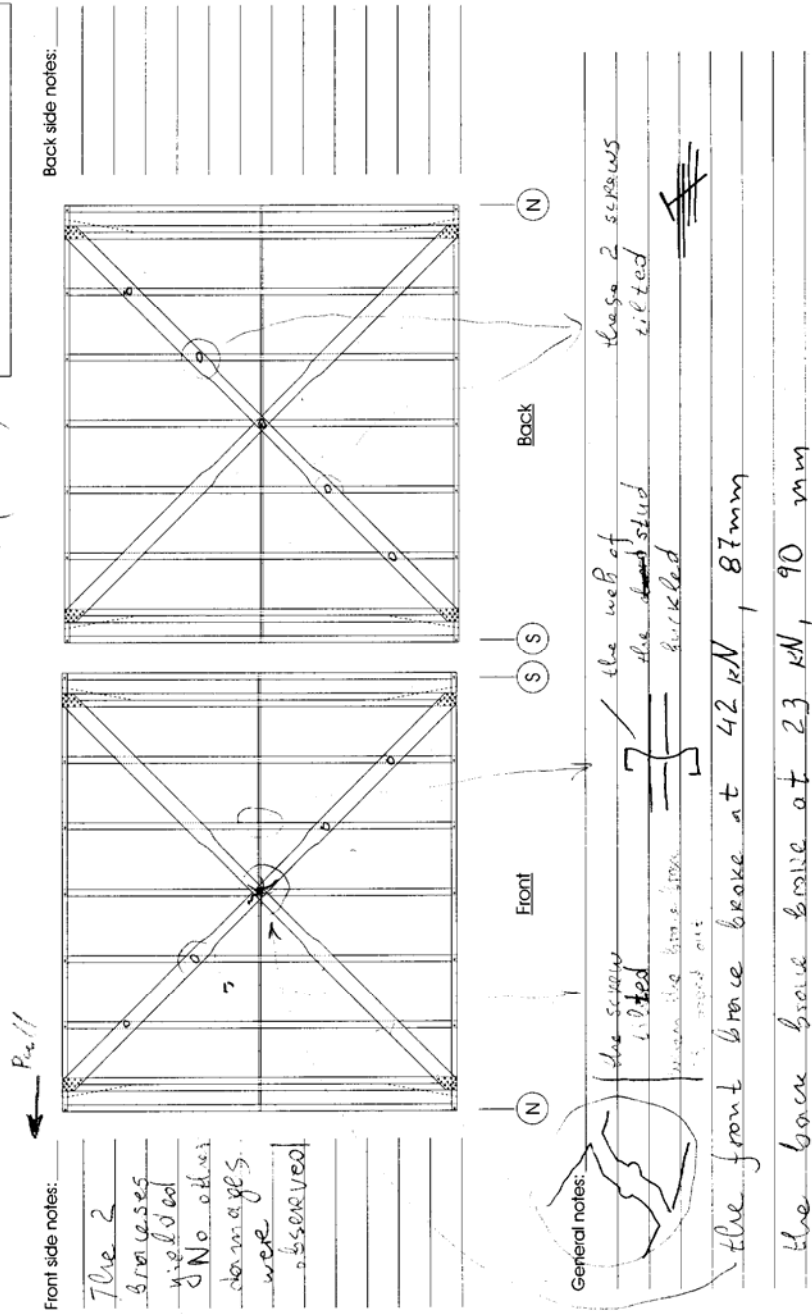

Figure C. 28 Observations for test 25 A-M 2



Cold Formed Steel Frame Strap Braced Shear Wall Testing

Test name : 26A-C
 Date tested : 23 July, 2007
 Wall Size : 9' x 8'
 Strap Size : 2.5"
 Extended Track : yes no
 Holddown : Inside Outside Raised
 Test mode : Cyclic Monotonic

the plane of fracture
 these braces broke in the middle
 position of straps

Front side notes:

test was
 successful
 braces yielded
 the braces
 with straps
 broke about
 at the end

No other
 damages
 were observed.
 chord studs
 were not
 damaged
 at all.

General notes:

Back side notes:

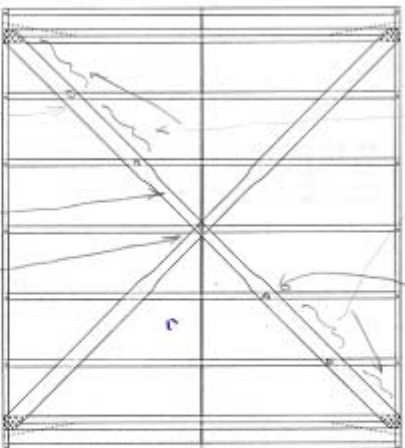
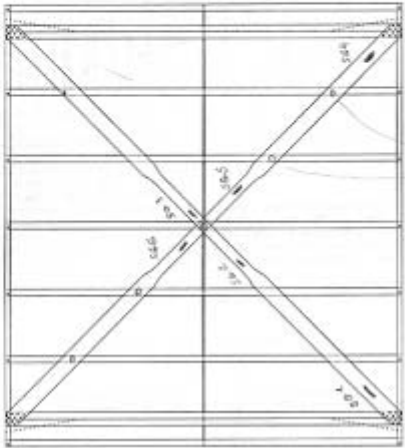

(N) this screw failed in pull out
 (S) braces with screw yielded also in these areas.
 (N) these 2 screws popped out they failed in shear

Figure C. 29 Observations for test 26 A-C



Cold Formed Steel Frame-Strap Braced Shear Wall Testing

$f_y = 53.9 \text{ MPa}$ (57 ksi) $\approx 20 \text{ mm}$
 $f_u = 19.2 \text{ MPa}$ (80 ksi) ≈ 20
 $\Delta u = 14.2 \text{ mm}$ (20 mm)
 concrete 27 MPa (4 ksi)

Test name : 27A-M-1
 Date tested : July 3, 2007
 Wall Size : 9'x8'
 Strap Size : 2.75"
 Extended Track : yes no
 Holddown : Inside Outside Raised
 Test mode : Cyclic Monotonic

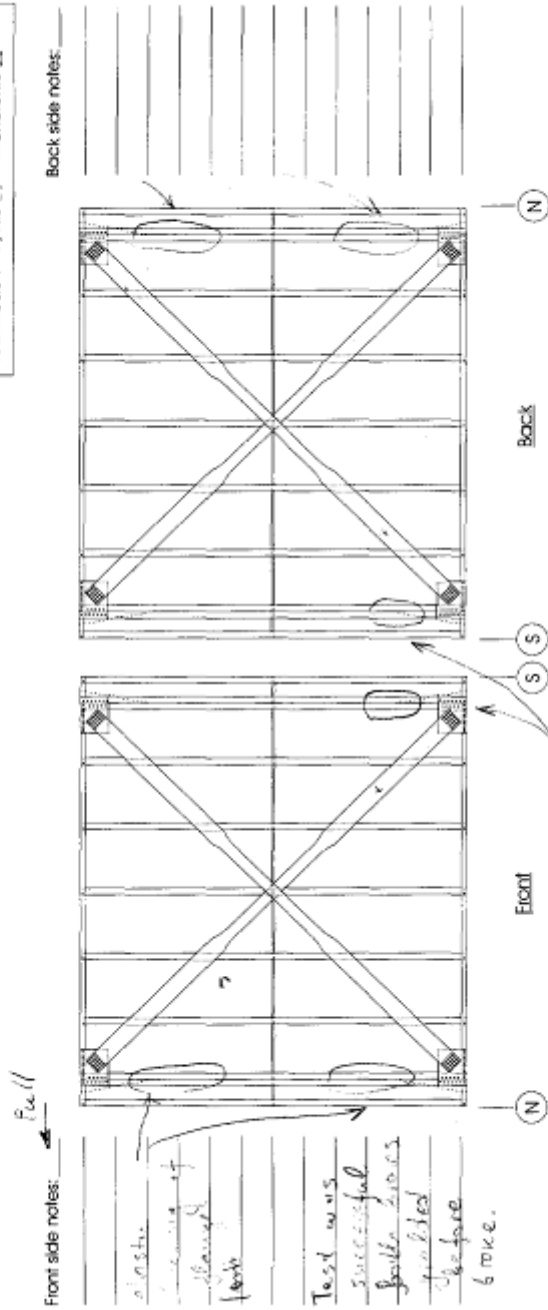

Front side notes:

elastic buckling of flanges
 brace broke at $b=200 \text{ mm}$
 Test was successful
 failure loads stabilized before
 broke.

General notes:

elastic buckling of flanges } brace broke
 $F = 80 \text{ kN}$, $b = 200 \text{ mm}$
 second brace broke at $F = 45 \text{ kN}$, $\Delta = 210 \text{ mm}$
 The first brace broke in very unexpected way

Back side notes:

no other
 damages
 were
 observed

Figure C. 30 Observations for test 27 A-M 1



Cold-Formed Steel Frame-Strip-Biased Shear Wall Testing

$F_y = 53.9 \text{ ksi (test)}$
 $F_u = 78.2 \text{ ksi}$
 $\Delta_{ult} = 172 \text{ mm}$
 $\Delta_{max} = 291 \text{ mm}$

Test name : 27A-M 2
 Date tested : June 22, 2007
 Wall Size : 9x8
 Strap Size : 2.75
 Extended Track : yes no
 Holddown : inside Outside Raised
 Test mode : Cyclic Monotonic

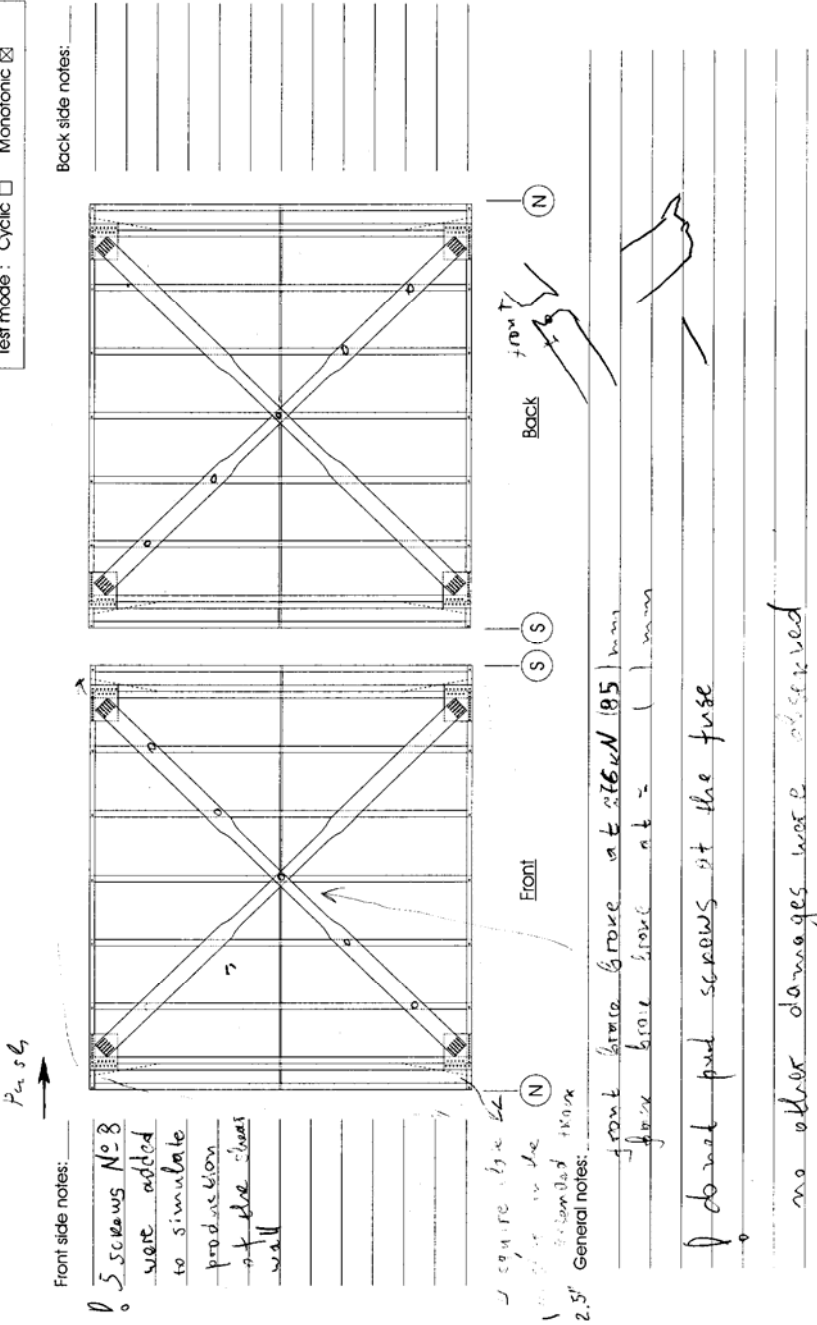

Figure C. 31 Observations for test 27 A-M 2



Cold Formed Steel Frame Strap Braced Shear Wall Testing

Test name : 28A-C
 Date tested : 24. Feb. 2007
 Wall Size : 9x8
 Strap Size : 2.75
 Extended Track : yes no
 Holddown : Inside Outside Raised
 Test mode : Cyclic Monotonic

position of screws

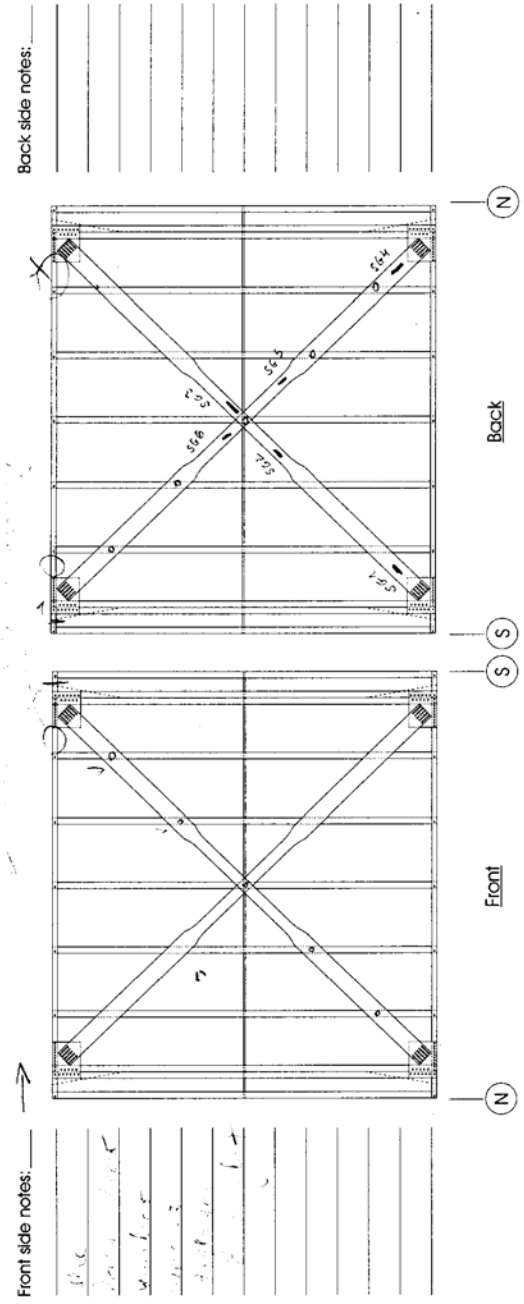

General notes:
 Some are fast with the reading of the test results

Figure C. 32 Observations for test 28 A-C



Cold Formed Steel Frame Shear Braced Shear Wall Testing

Furling = 87.7 wt

Fult = 125.6 kN

$\Delta_{ult} = 172$

$\Delta_{max} = 301 \text{ mm}$

Test name: 29A-M-1, 22
 Date tested: June 14, 2007
 Wall Size: 9'x8'
 Strap Size: 4" reduced section strap
 Extended Track: Yes no
 Holddown: Inside Outside Raised
 Test mode: Cyclic Monotonic

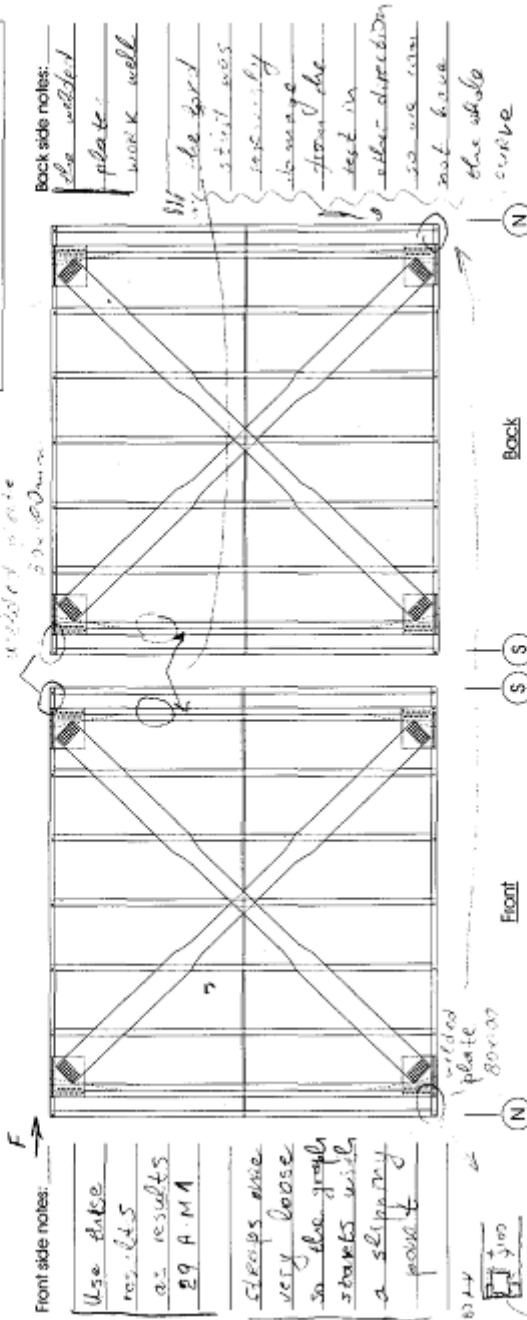

Figure C. 33 Observations for test 29 A-M 1



Cold Formed Steel Frame Shear Wall Testing

! don't use the data from Steing pot

Test name: 29A-M-2 2C
 Date tested: June 18, 2007
 Wall Size: 9'x 8'
 Slap Size: 4" reduced section slap.
 Extended Track: yes no
 Holddown: Inside Outside Raised
 Test mode: Cyclic Monotonic

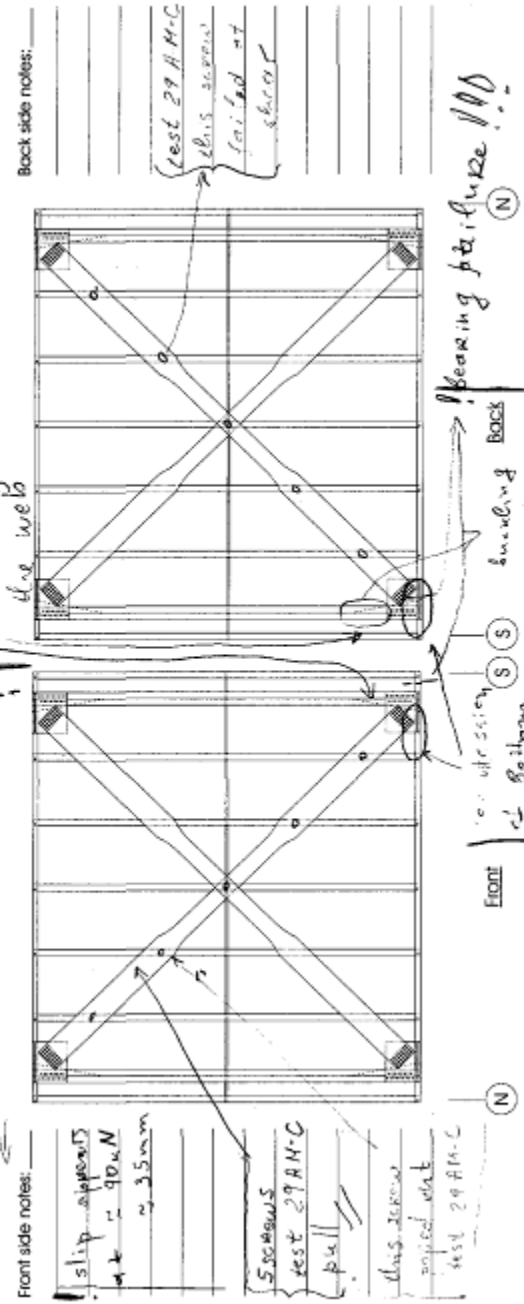

Front side notes:
 slip appears at ~ 90kN ~ 35mm
 5 screws test 29A-M-C
 diag. shown typical data test 29A-M-C

Back side notes:
 test 29 A-M-C this screw failed at 8000

General notes:

test 29 A-M 2	test	data from test 29 A-M 2C (5 July 2007)
29 A-M 2b	continued	5 screws were added

$F_y = 88 \text{ kN}$
 the small bumps in the graph are from the pop out of screws
 $F = 118 \text{ kN}$ at 118 mm - front brace broke first
 $F = 60 \text{ kN}$ at 126 mm - back brace broke
 see back.

Figure C. 34 Observations for test 29 A-M 2



Cold Formed Steel Frame Strap Braced Shear Wall Testing

Test name : 30 A-C
 Date tested : Aug 5, 2007
 Wall Size : 9' x 8'
 Strap Size : 4" reduced section strap
 Extended Track : yes no
 Holddown : Inside Outside Raised
 Test mode : Cyclic Monotonic

may be SG 3
 was cut during the test

Front side notes:

test was successful
 beams embedded

Back side notes:

HD is outside

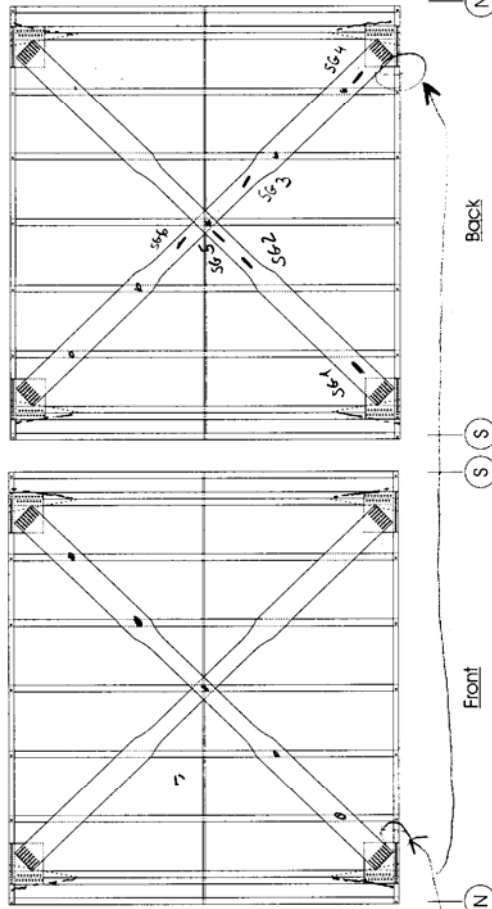

General notes:

strain gauges SG3 and SG5 - places changed
 slight compression/bending of bottom member was observed

Figure C. 35 Observations for test 30 A-C

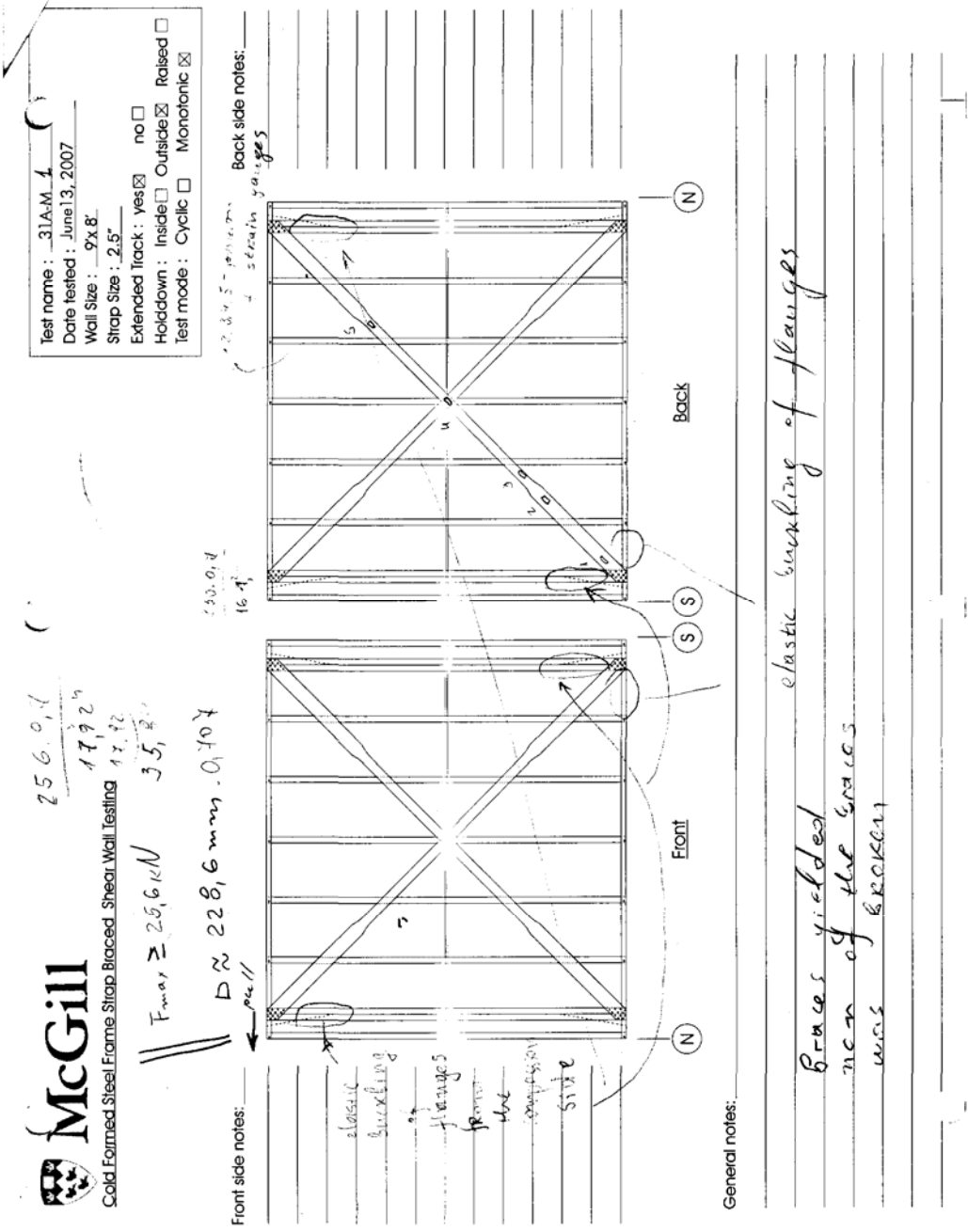

Figure C. 36 Observations for test 31 A-M 1

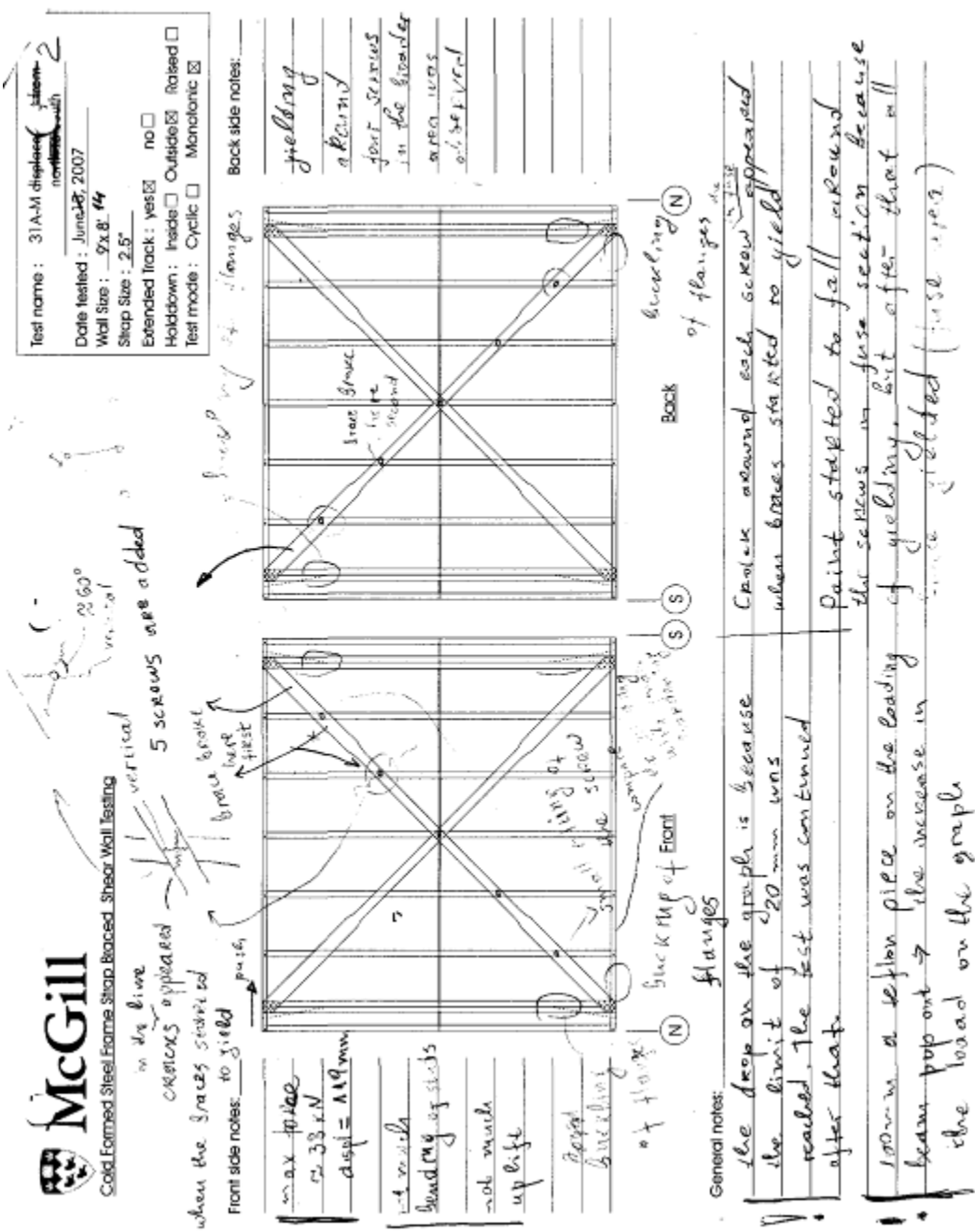
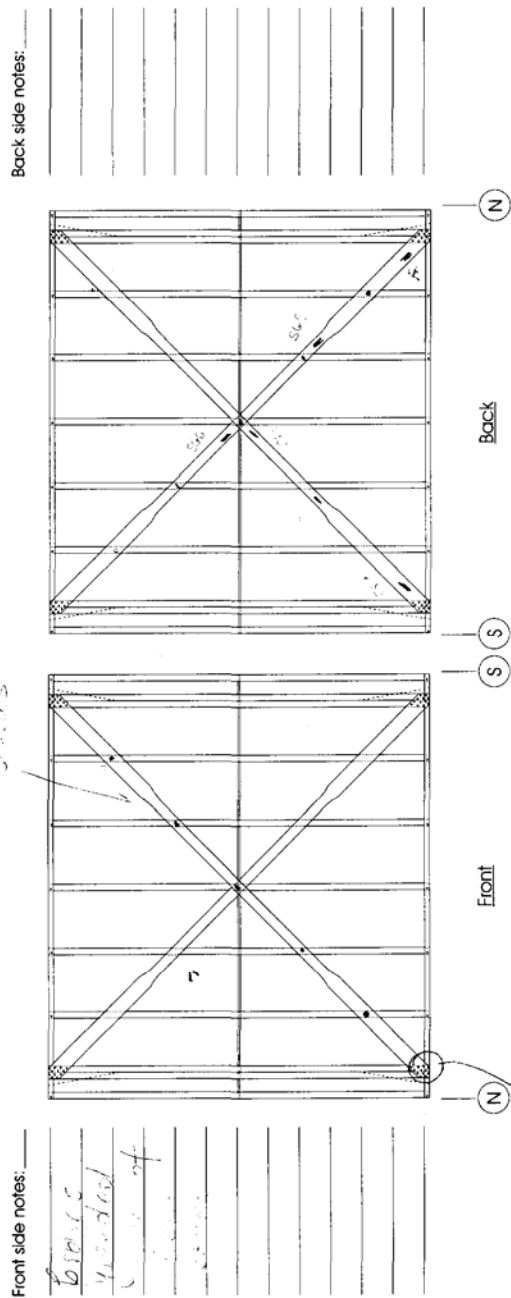

Figure C. 37 Observations for test 31 A-M 2



Cold Formed Steel Frame Strap Braced Shear Wall Testing

Test name : 32A-C
 Date tested : 2007
 Wall Size : 9x8
 Strap Size : 2.5"
 Extended Track : yes no
 Holddown : Inside Outside Raised
 Test mode : Cyclic Monotonic



General notes:

the connection was ok.

Diagonal studs: flanges were bended because of bad connection.

these screws were not in the track so the full force was transferred thru the flanges. flanges too

Figure C. 38 Observations for test 32 A-C



Cold Formed Steel Frame Stirrup Braced Shear Wall Testing

position of strain gauges → only 2 strain gauges

Test name : 33A-M1
 Date tested : July 4, 2007
 Wall Size : 7x8'
 Strap Size : 4" reduced section strap
 Extended track : yes no
 Holddown : Inside Outside Raised
 Test mode : Cyclic Monotonic

Back side notes:

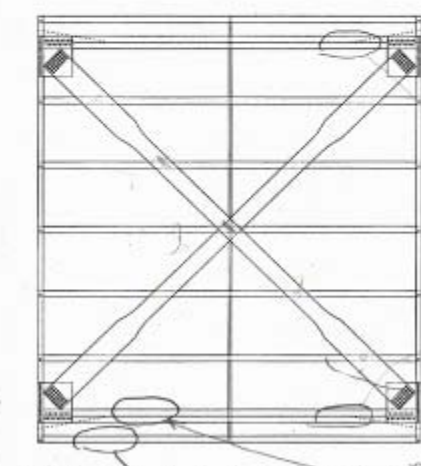
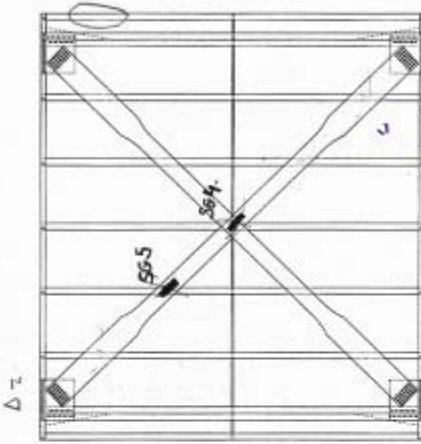

Front side notes:
 $F_y = 94 \text{ kN}$
 test stud buckled

elastic buckling of flanges
 This stud buckled because it was restricted from the screw in the brace
 Braces yielded
 none of the braces broken were
 damages in the chord studs were observed caused from large displacement,

Figure C. 39 Observations for test 33 A-M 1



Cold Formed Steel Frame Strap Braced Shear Wall Testing

$F_y = 87.7$
 $F_u = 125.6$

Test name : 33A-M-2
 Date tested : July 4, 2007
 Wall Size : 9x8
 Strap Size : 4" reduced section strap.
 Extended track : yes no
 Holddown : Inside Outside Raised
 Test mode : Cyclic Monotonic

5 screws were added
 all nuts are ~~flipped~~ for test 33A-M-2a
 b_{max}

test was started at 40mm test continued July 5

Back side notes:

test 33A-M-2a
 the screws
 connecting
 two chords
 failed
 The test
 was stopped
 because
 the column
 composed of
 2 TC failed
 The knees
 yielded.
 The column
 failed some
 1/2 in the 3rd
 floor

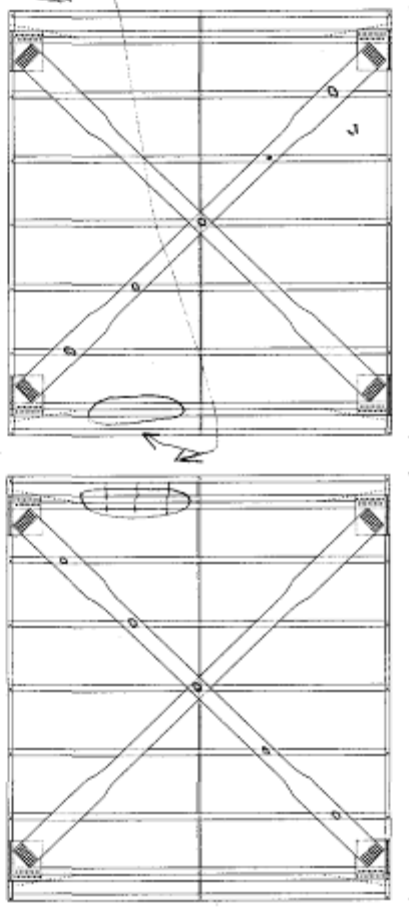

General notes:

test 33A-M-2a -> continued of test 33A-M-2
 the frame was test used for another test in we may
 have slightly different results.

($F_y = 95 \text{ kN}$ test)

test, 33A-M-2a -> continued of test 33A-M-2a July 08, 2007
 see page of the page



Cold Formed Steel Frame Strap Braced Shear Wall Testing

Test name : 34A-C
 Date tested : 30 July, 2007
 Wall Size : 9'x8'
 Strap Size : 4" reduced section strap.
 Extended Track : yes no
 Holddown : Inside Outside Raised
 Test mode : Cyclic Monotonic

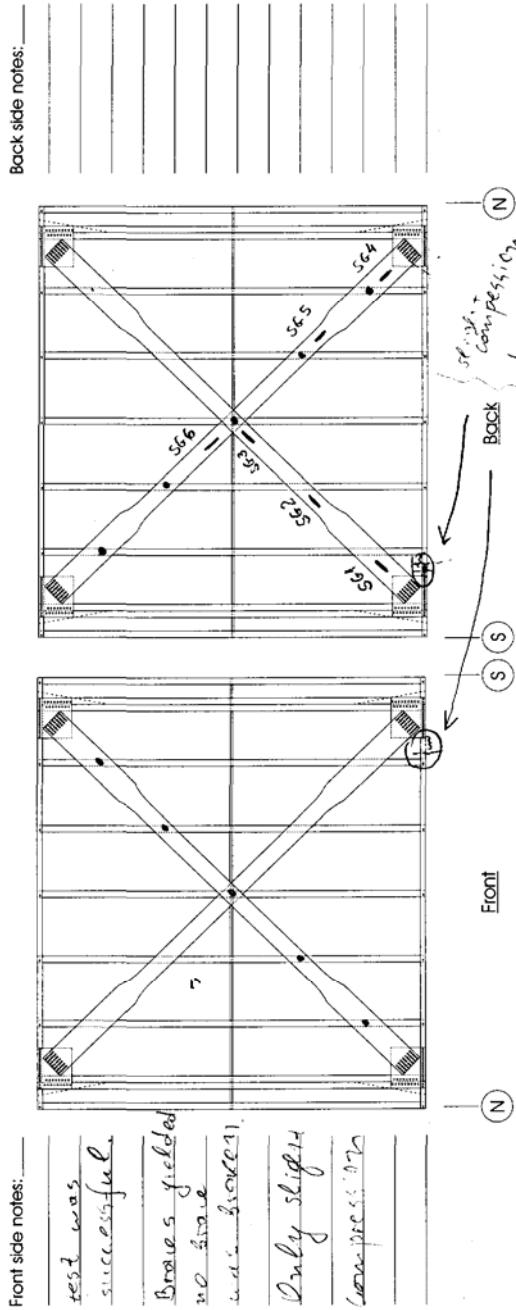

test was successful.
 Braces yielded w/o brace w.t. broken.
 Only slight compression on

||| there the south slip may be due to a bending failure

Figure C. 41 Observations for test 34 A-C

Test name : 35A-M
 Date tested : June 4, 2007
 Wall Size : 9'x8'
 Strap Size : 2.5"
 Extended track : yes no
 Holddown : Inside Outside Raised
 Test mode : Cyclic Monotonic

McGill
 Cold Formed Steel Frame Shear Braced Shear Wall Testing

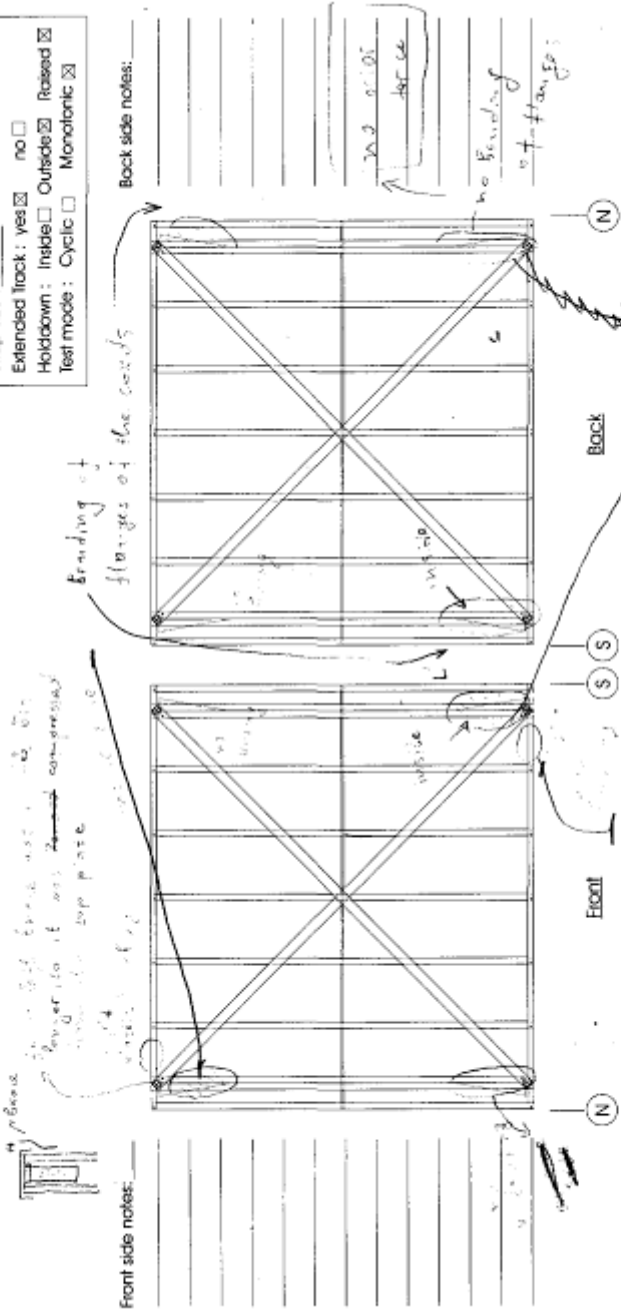

Front side notes: _____
 Back side notes: _____
 General notes: 120 mm x 25 strength bracing strap
 FN 35
 All the deformation in studs was almost 100% elastic
 ! braces yielded
 The second brace right brace failure at 1.0

Figure C. 42 Observations for test 35 A-M



Cold Formed Steel Frame-Strap Braced Shear Wall Testing

Test name : 36 A-C
 Date tested : 25 June 2007
 Wall Size : 9x8
 Strap Size : 2.5"
 Extended Track : yes no
 Holddown : Inside Outside Raised
 Test mode : Cyclic Monotonic

This brace was a 0.46 size
positioned by screws

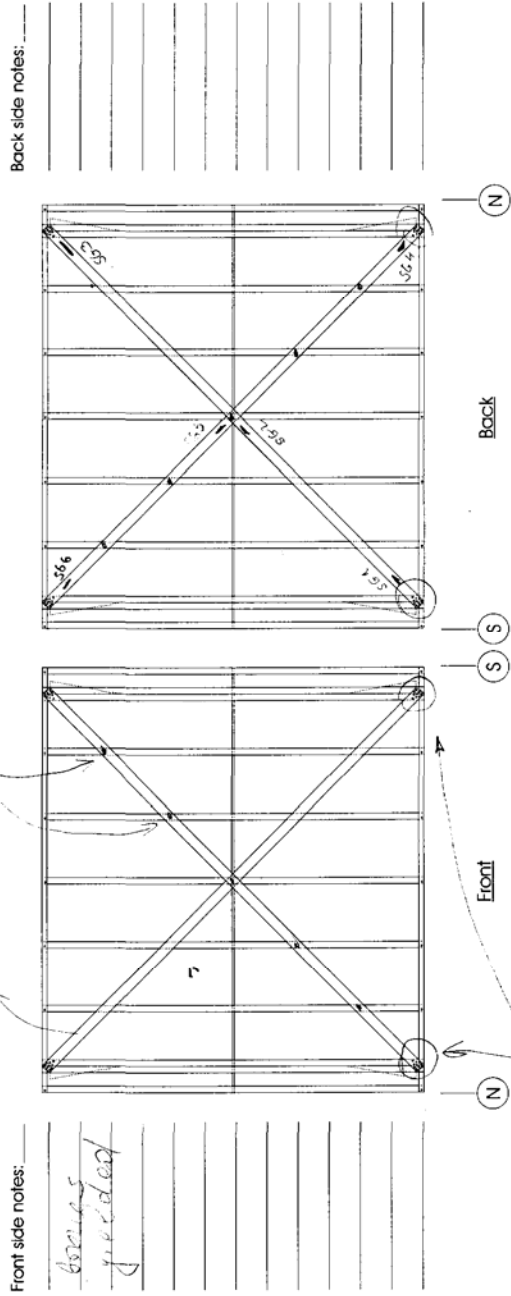

General notes:
 - failure of the board and screws only on the bottom side. The interior
 parts of the wall were removed from the tension force
 at failure

Figure C. 43 Observations for test 36 A-C



Cold Formed Steel Frame Shear Wall Testing

for 38 A-C → HD th & e + another
slight anchor
→ a plate 80 x 100 mm
was used for the
uplifting case.

$F_{max} = 93 \text{ kN}$

Test name: 37A-M
 Date tested: May 23, 2007
 Wall Size: 9' x 8'
 Strap Size: 4"
 Extended track: yes no
 Hold-down: Inside Outside Raised
 Test mode: Cyclic Monotonic

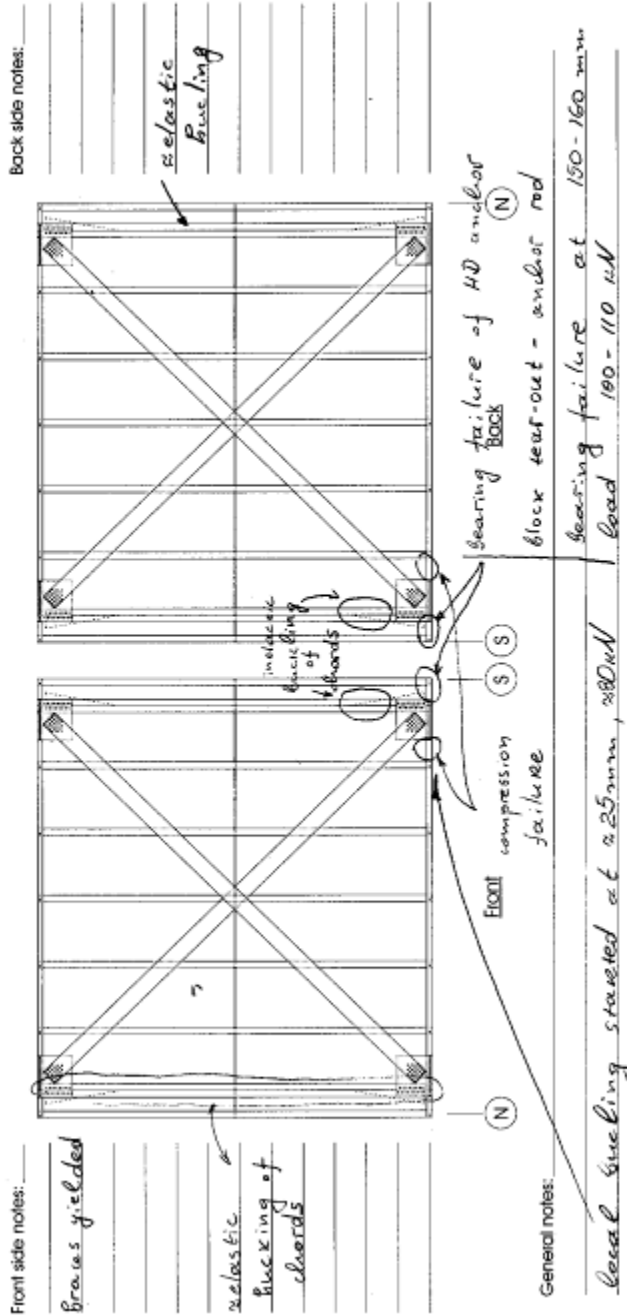

Front side notes:

braces yielded
elastic buckling of chords

Back side notes:

elastic buckling

General notes:

local buckling started at a 25mm, 880kN
 It is better the HDs to be placed inside → they will allowed bigger rotation and the contraction will be closer to pinned.

Figure C. 44 Observations for test 37 A-M



Cold Formed Steel Frame Strip Braced Shear Wall Testing

Test name : 38A-C
 Date tested : 7/24/07
 Wall Size : 9'x8'
 Strip Size : 4"
 Extended Track : yes no
 Holddown : Inside Outside Raised
 Test mode : Cyclic Monotonic

Front side notes:

test was successful
 Braces yielded
 Only slight buckling
 Bending or compression failure
 General notes:

studs

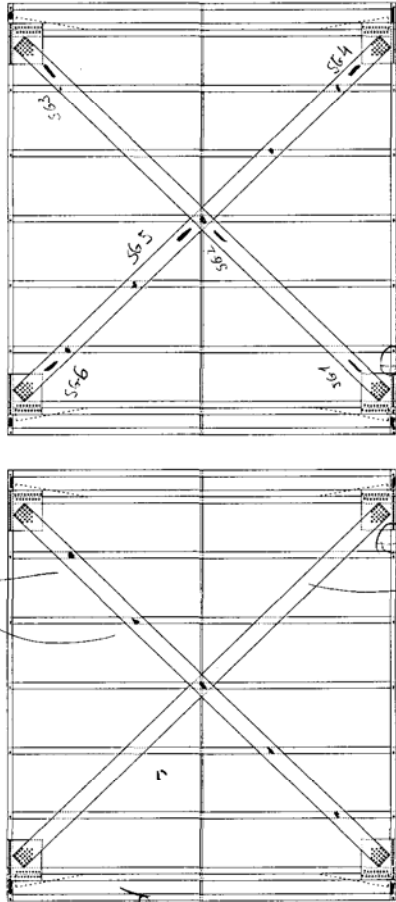

Back side notes:

plate 80x180mm, 2077, 50ksi was welded to the track in order to prevent bearing failure

General notes: this brace is slightly narrower

slight compression or bending failure

Figure C. 45 Observations for test 38 A-C



Cold Formed Steel Frame Strap Braced Shear Wall Testing

Test name : 39A-M
 Date tested : May 23, 2007
 Wall Size : 8' x 8'
 Strap Size : 2.75"
 Extended track : yes no
 Holddown : Inside Outside
 Test mode : Cyclic Monotonic

problems with screws
 was not detected
 slight buckling of the top brace
 between struts
 some
 brace
 failure

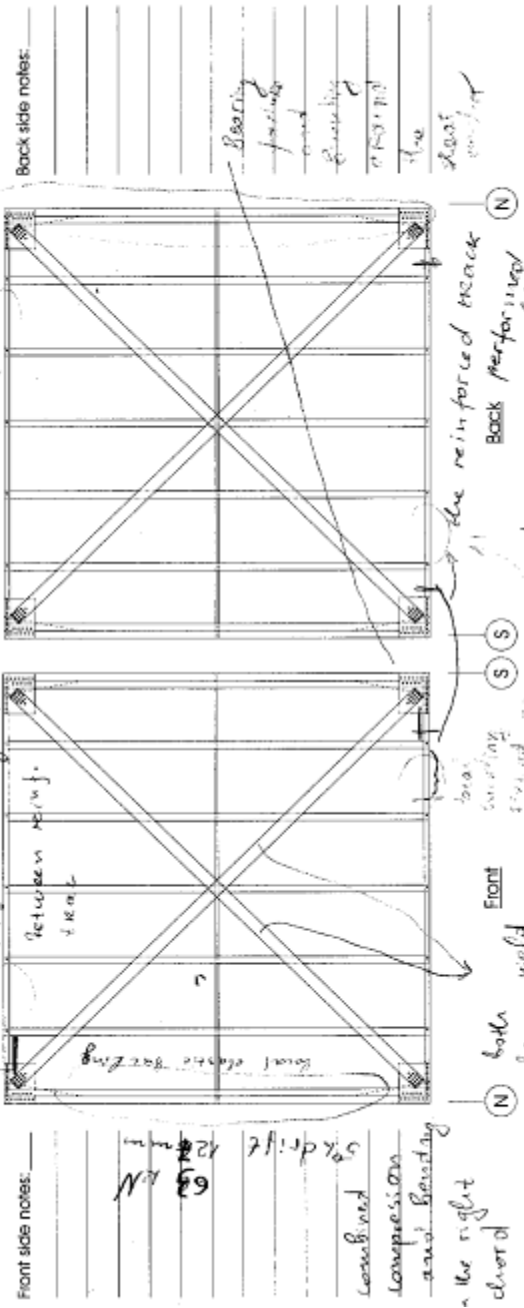

Front side notes:
 63 kN
 5% drift
 combined
 compression
 and bracing
 the right
 chord
 both
 braces yield
 Front
 Back
 N
 S
 S
 N

Back side notes:
 bearing failure
 the reinforced brace
 Back performing well
 located between a shear member
 and the end of the member
 General notes:
 Some slaking occurred in the
 20 studs slipped. After the slipping
 stopped the photo was reached and
 the load stopped
 the brace stopped
 the time and was

Figure C. 46 Observations for test 39 A-M



Cold Formed Steel Frame Strap Braced Shear Wall Testing

Test name : 40 A-C
 Date tested : , 2007
 Wall Size : 8x8'
 Strap Size : 2.75"
 Extended Track : yes no
 Holddown : Inside Outside Raised
 Test mode : Cyclic Monotonic

position of screws

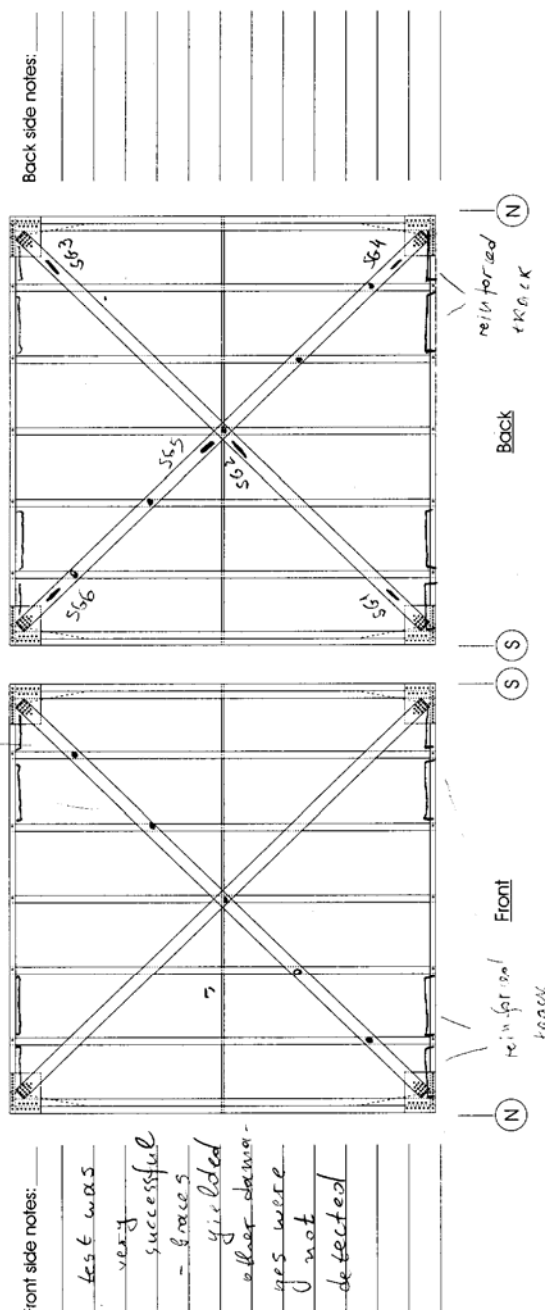

front side notes:
 test was
 very
 successful
 - braces
 yielded
 other dama-
 ges were
 not
 detected

Back side notes:

General notes:
 the actuator struck when it reached 120 mm - check the data
 for the CURE protocol the last cycle the negative - 120 missing

Figure C. 47 Observations for test 40 A-C



Cold Formed Steel Frame Strap Braced Shear Wall Testing

Test name : 41A-M
 Date tested : August 8, 2007
 Wall Size : 8x8
 Strap Size : 4"
 Extended Track : yes no
 Holddown : U-Shape Cyclic Monotonic

screws only on the back brace

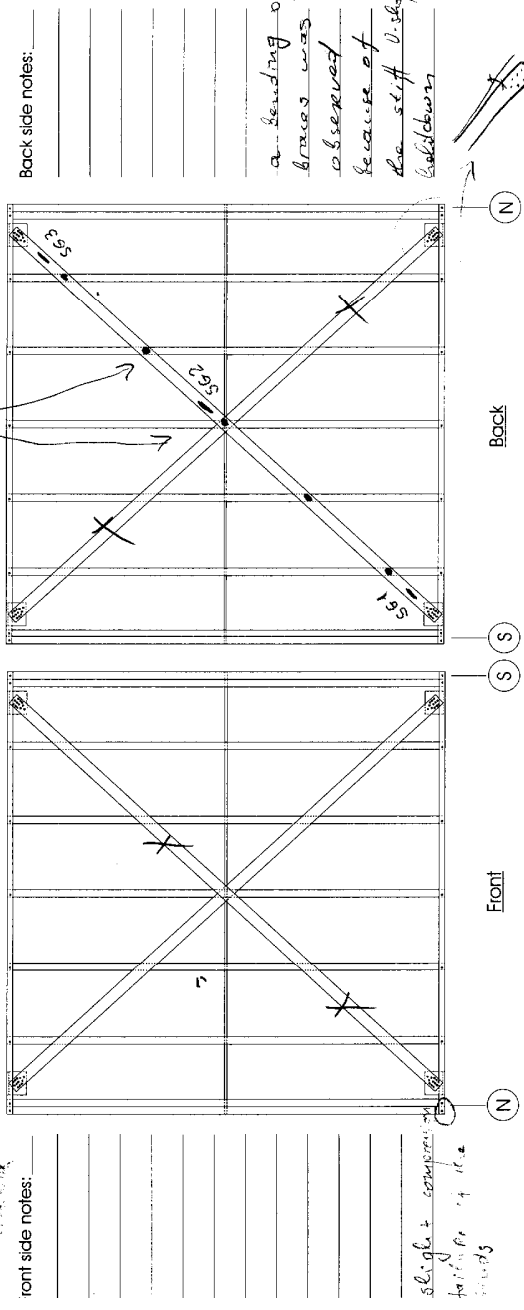

Front side notes:

Back side notes:

General notes: Only one brace was placed on the wall. Only back brace was attached with screws

Test was successful. Braces yielded. U-shaped HD were not damaged at all. Studs and nails were not damaged at all.



Cold-Formed Steel Frame Strap Braced Shear Wall Testing

Test name : 42 A-C
 Date tested : August 10, 2007
 Wall Size : 8x8
 Strap Size : 4"
 Extended track : yes no
 Holddown : U-Shape
 Test mode : Cyclic Monotonic

screws everywhere

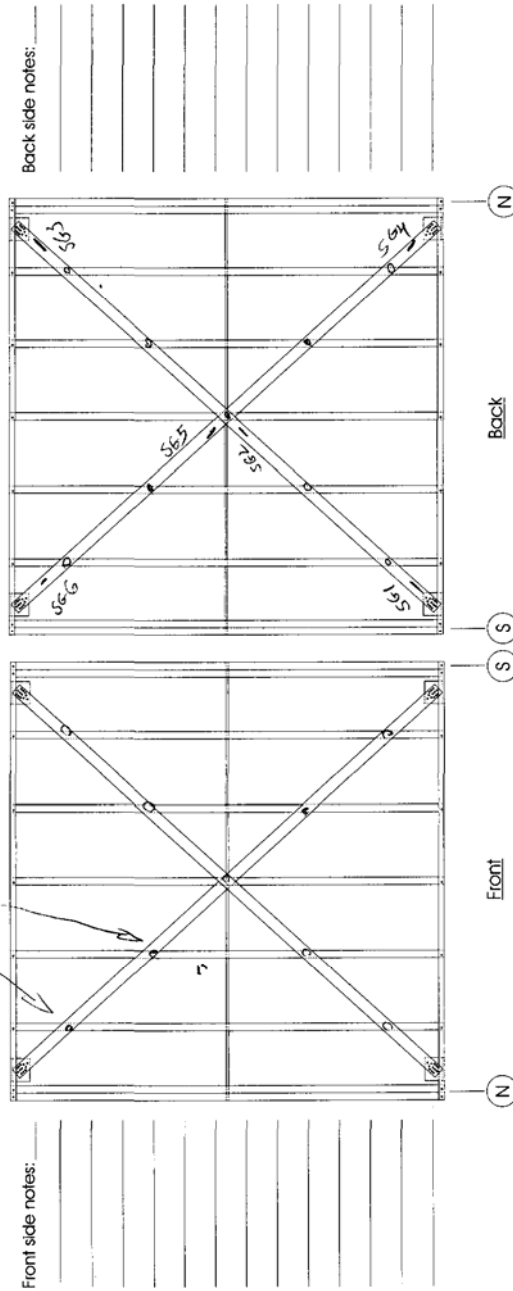

Front side notes:

Back side notes:

General notes:
 Test was successful bracing yielded. No other damages were observed.

Figure C. 49 Observations for test 42 A-C



Cold Formed Steel Frame Strap Braced Shear Wall Testing

Test name : 43 A-M *new straps*
 Date tested : August 2007
 Wall Size : 8x8
 Strap Size : 4"
 Extended Track : yes no
 Holddown : U-Shape
 Test mode : Cyclic Monotonic

Only one brace was placed
only front brace was attached with screws

Front side notes:
 Test 43 A-M
 new STRAPS
 was successful
 Test was
 stopped at
 a 206 mm.
 braces yielded
 U-shaped HD
 performed
 very well.
 No other
 damages
 was observed.

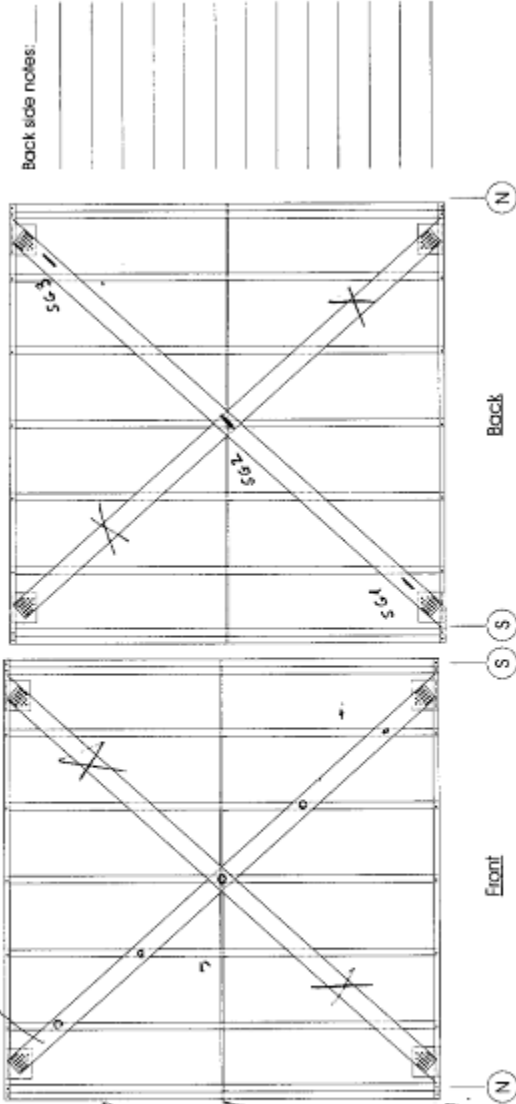

General notes:

the top flange of the beam failed, so the straps were changed and a new test, 43 A-M new straps were used.

New straps were not painted, not screwed and straps gauges were not installed.

Figure C. 50 Observations for test 43 A-M



Cold Formed Steel Frame Strap Braced Shear Wall Testing

Test name : 44 A-C
 Date tested : August 12, 2007
 Wall Size : 8x 8'
 Strap Size : 4"
 Extended Track : yes no
 Holddown : U-Shape
 Test made : Cyclic Monotonic

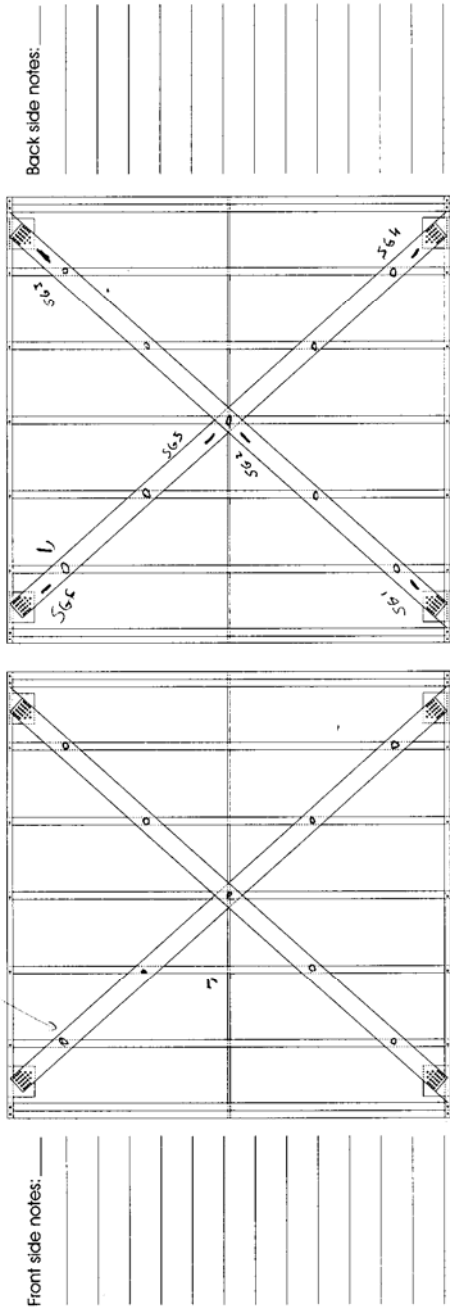

N S S N Front Back

General notes: *test was successful, braces yielded. No other damages were observed.*

Figure C. 51 Observations for test 44 A-C

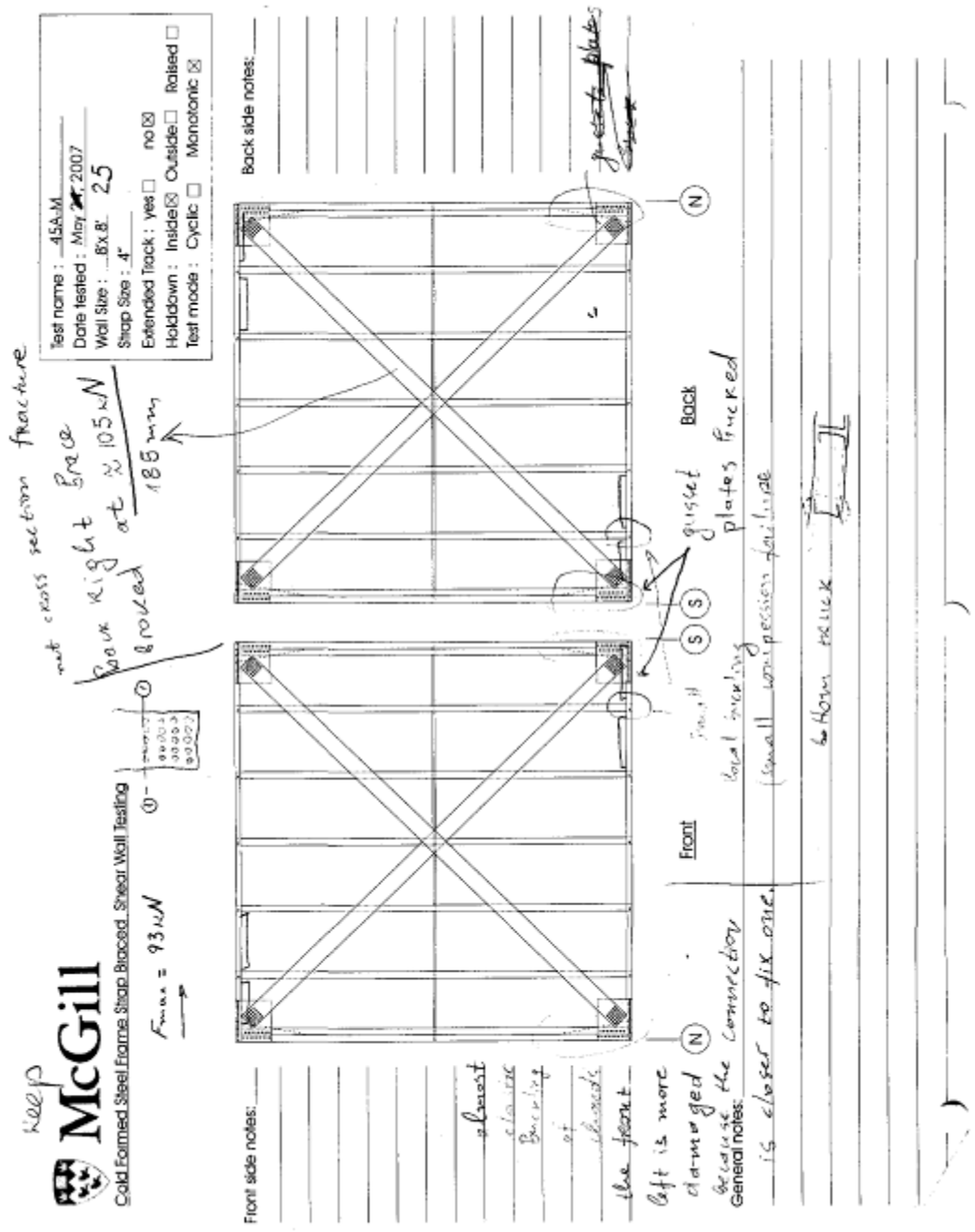

Figure C. 52 Observations for test 45 A-M



Cold Formed Steel Frame-Strap Braced Shear Wall Testing

Test name : 46 A-C
 Date tested : August 3, 2007
 Wall Size : 8' x 8'
 Strap Size : 4"
 Extended Track : yes no
 Holddown : Inside Outside Raised
 Test mode : Cyclic Monotonic

position of sensors

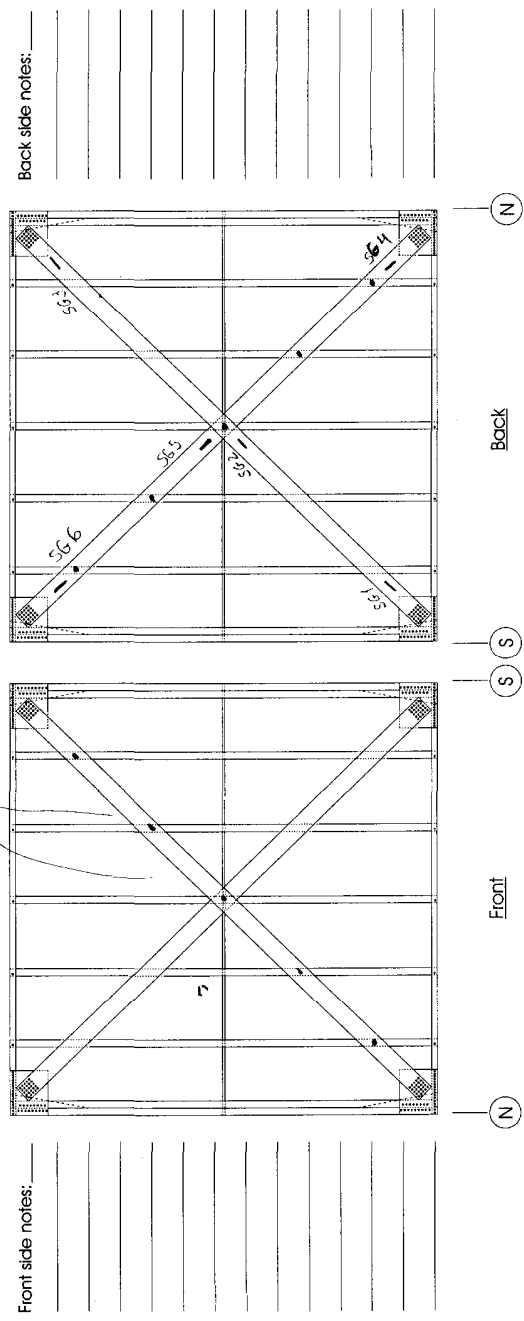

Front side notes:

Back side notes:

General notes:
 test was very successful. Braces yielded. No other damages were observed.
 For this was 5mm strain gauges were used. The factor value was not changed.

Figure C. 53 Observations for test 46 A-C

Test name : 47A-M
Date tested : May 28, 2007
Wall Size : 8x8
Strip Size : 2,75
Extended track : yes
Holdown : Inside Outside Raised
Test mode : Cyclic Monotonic

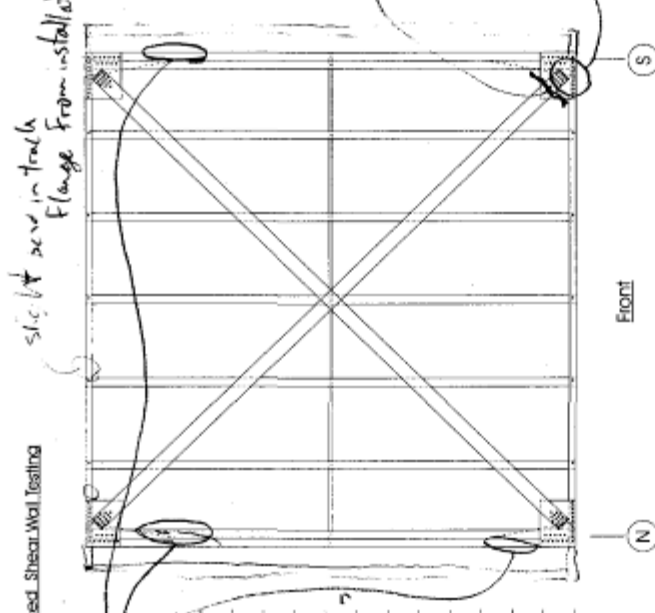

Front side notes:
Change strip
Bearing on inside
 $\Delta = 172 \text{ mm}$

Load cell reading high. corner of HD is pressing into bottom track causing reaction

Strip fracture just after test was stopped.

Load @ 4.16kN from gusset plate alone.

General notes: Strip & Gusset plate on front of wall only.

String pot clip not completely free of wall, check for slight e_{wall} displacement

Figure C. 54 Observations for test 47 A-M



Cold Formed Steel Frame Strap Braced Shear Wall Testing

Test name : 48A-C
 Date tested : July 30, 2007
 Wall Size : 8'x9'
 Strap Size : 2.75"
 Extended Track : yes no
 Holddown : Inside Outside
 Test mode : Cyclic Monotonic

Front side notes:

Back side notes:

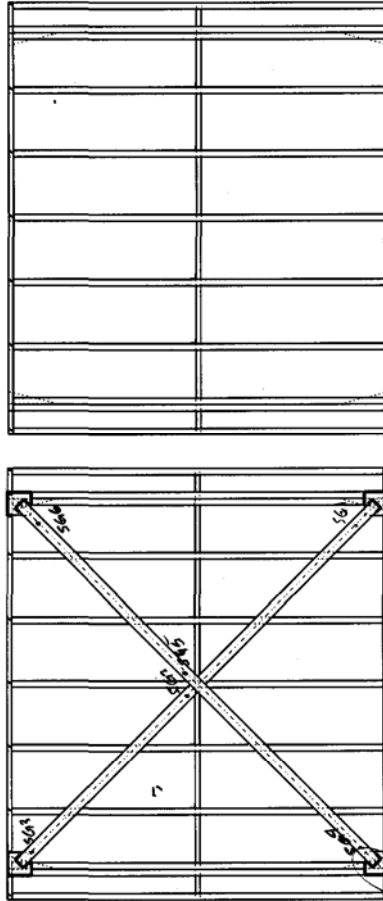

Front

Back

General notes: Note: screwed connections used. No welts.
 straps on front side of wall only.

APPENDIX D

RUAUMOKO INPUT FILES

```

3.14 0.001 33 -33      !KX RF FX+ FX- (from test 42A-C results)
5                      !5 = Bi-linear with slackness Hysteresis Model
0                      !0 = No Strength Degradation (Not available)
0.0 0.0 0 0.001 0.0 0.0 0 !GAP+ GAP- IMODE RCOMP C EPSO ILOG
0                      !ILOS (=0, no strength degradation)
0                      !DINIT (initial displacement)
3 1                    !IHIST SCALE
-0.00394
-0.00394
-0.006895
0
-0.01576
-0.014775
-0.03349
-0.01576
-0.048265
-0.030535
-0.052205
-0.04531
-0.03743
-0.060085
-0.04531
-0.048265
-0.05319
-0.048265
-0.04531
-0.04925
-0.04137
-0.052205
-0.03743
-0.04531
-0.03743
-0.03743
-0.034475
-0.03743
-0.03743
-0.03743
-0.03743
-0.03743
-0.03743
-0.026595
-0.03349
-0.038415

Cont'd... remaining values not shown)

STOP

```

Figure D.1 HYSTERES input file for hysteretic behaviour matching, based on test 42 A-C

```

Vancouver 2 storey Rd=1.25 Ro=1.3      ! Units kN, m and s
2 0 1 0 0 0 1 0 0                    ! Principal Analysis Options
6 4 3 2 1 2 9.81 5 5 0.005 60.0 1    ! Frame Control Parameters
0 0 1 0 1                              ! Output Intervals and Plotting Control Parameters
0 0                                      ! Iteration Control

NODES
1      0      0      1      1      1      0      0      0      3
2      0      3.66  0      0      1      0      0      0      0
3      0      6.71  0      0      1      0      0      0      0
4      3      0      1      1      1      0      0      0      3
5      3      3.66  0      0      1      2      0      0      0
6      3      6.71  0      0      1      3      0      0      0

ELEMENTS
1      1      1      2      0      0      0
2      2      2      3      0      0      0
3      3      4      5      0      0      0
4      3      5      6      0      0      0

PROPS
1 SPRING                                ! Brace
1 5 0 0 1000000 5974.7 0 0 0.010357    ! Basic Section Properties
1000000 -1000000 114.29-114.29         ! Yield Surface
0.0 0.0 0.0 0.010357 0.0 0.0 0        ! Bi-linear with Slackness Hysteresis

2 SPRING                                ! Brace
1 5 0 0 1000000 3818.1 0 0 0.016207    ! Basic Section Properties
1000000 -1000000 58.01-58.01          ! Yield Surface
0.0 0.0 0.0 0.016206956 0.0 0.0 0     ! Bi-linear with Slackness Hysteresis

3 SPRING                                ! Fictitious column
1 0 0 0 1000000

WEIGHT
1      0
2      157.7
3      60.4
4      0
5      0
6      0

LOAD
1      0      0      0
2      0      0      0
3      0      0      0
4      0      0      0
5      0      -195.4  0
6      0      -60.4   0

EQUAKE
3 1 0.005 1 60.0 0 0 1.0

START

```

Figure D. 2 RUAUMOKO input file for model Vancouver 2 storey

APPENDIX E

EXAMPLE HYSTERESIS AND TIME HISTORY FOR FIVE STOREY

VANCOUVER MODEL SUBJECTED TO SPECTRUM

MATCHED (SM) GROUND MOTION

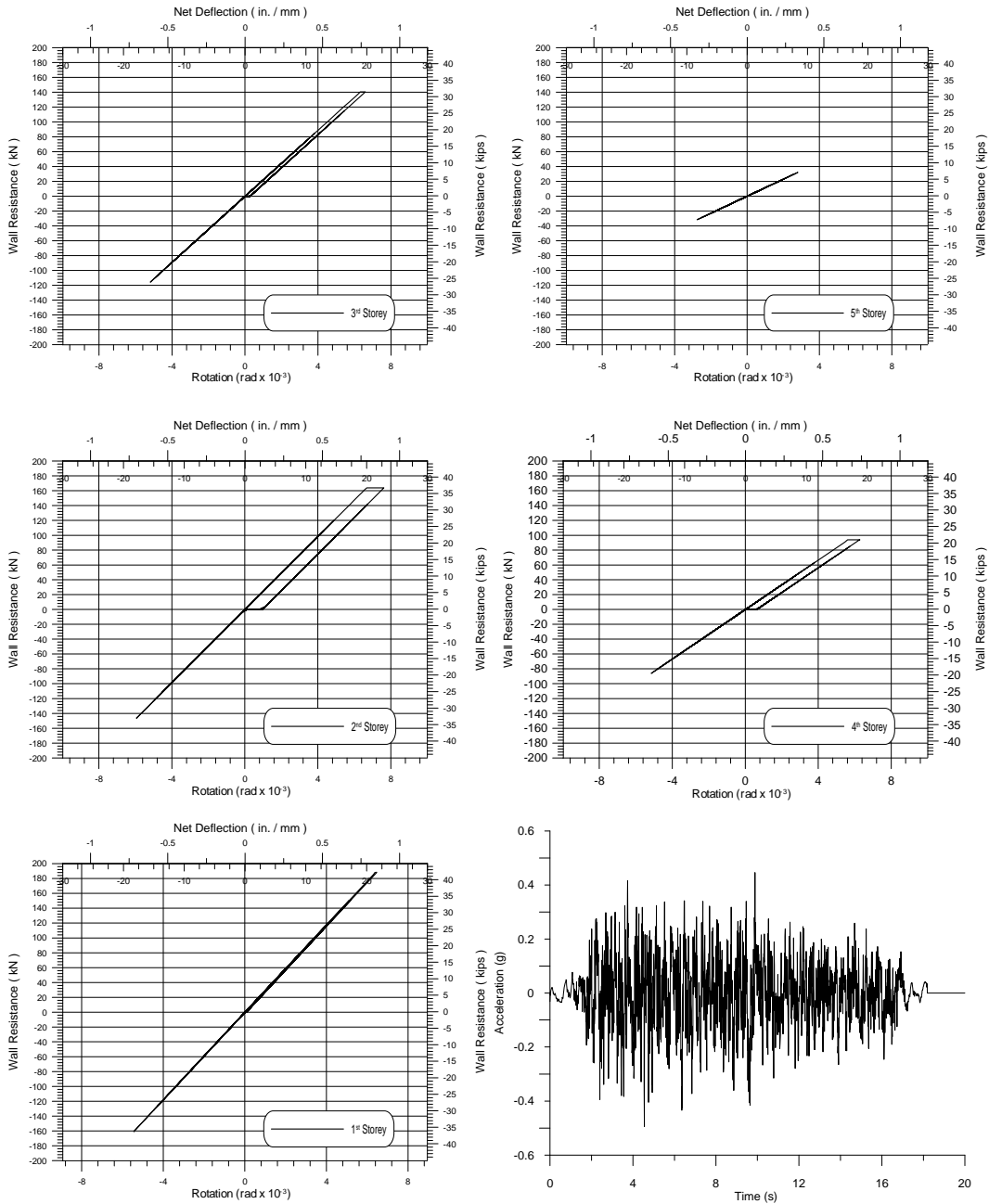

Figure E. 1 Hysteresis for each storey SM earthquake record, model 2 storey Vancouver

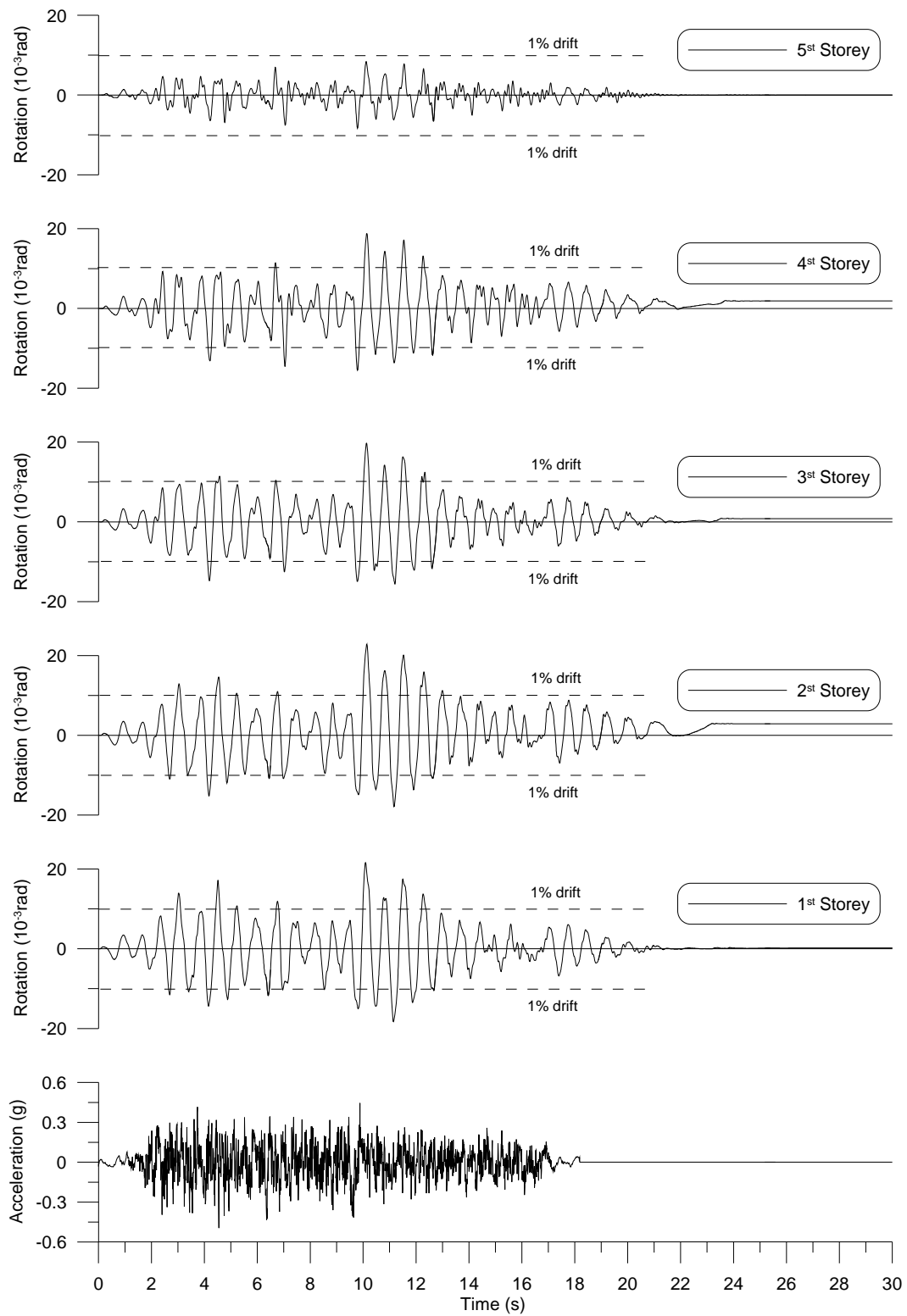

Figure E. 2 Time history showing rotation vs. time for each storey, SM earthquake record, model 2 storey Vancouver

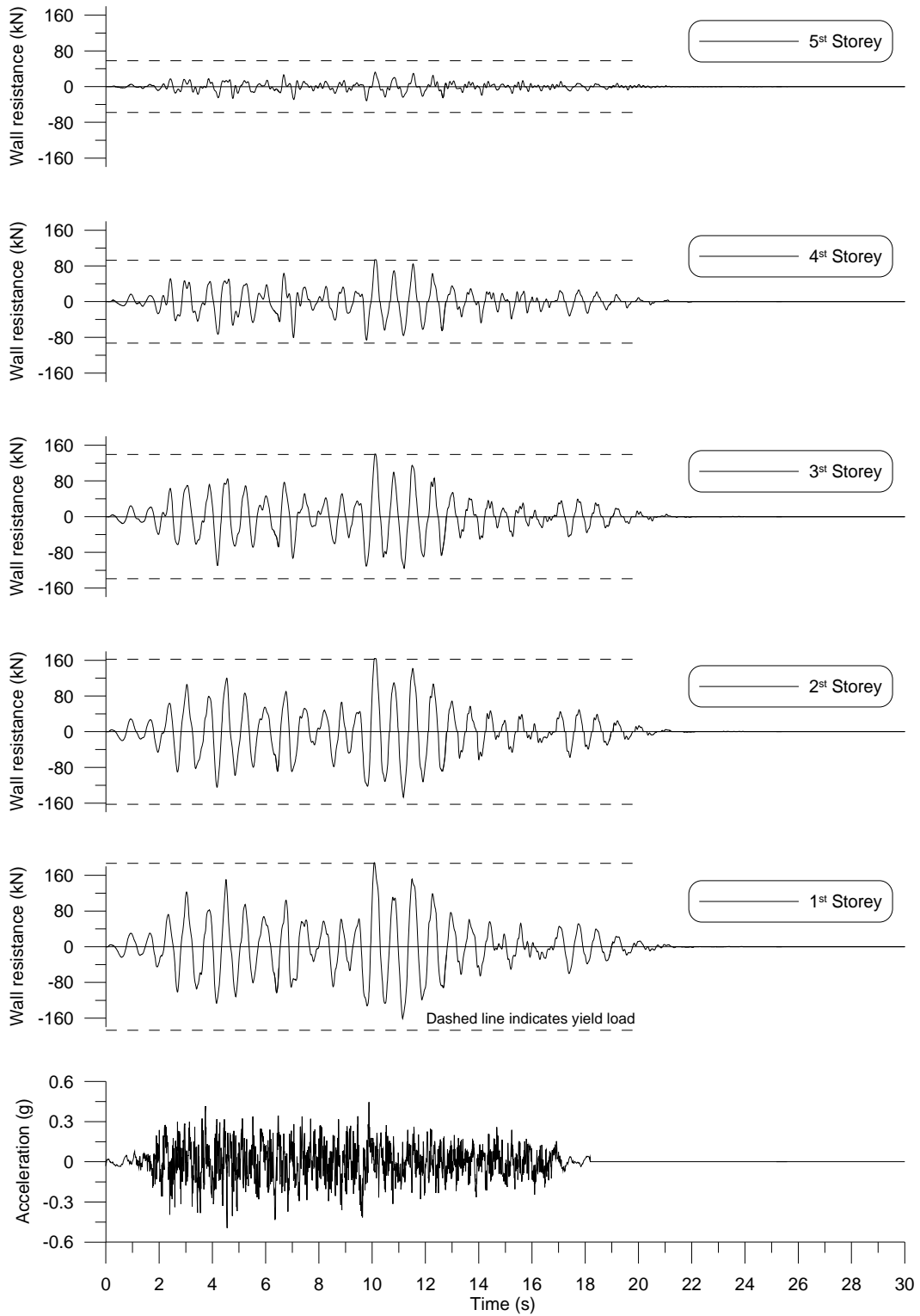

Figure E. 3 Time history showing resistance vs. time for each storey, SM earthquake record, model 2 storey Vancouver

APPENDIX F
SCREW CONNECTION TESTS

To assess the screw connection capacity of No. 10 x 3/4" (19 mm) wafer head self drilling screws tests as shown in (Figure F. 1) were carried out. The bearing / tilting capacity of No. 10 screws was determined for 1.09mm (0.043"), 230MPa (33 ksi) steel; 1.37 mm (0.054") and 1.73mm (0.068"), 340 MPa (50 ksi) steel representing the steel used for braces. In order to estimate the shear capacity of the screw itself 2.46 mm (0.097") thick 340 MPa (50 ksi) steel plates were used. Test results are presented in (Table F. 1)

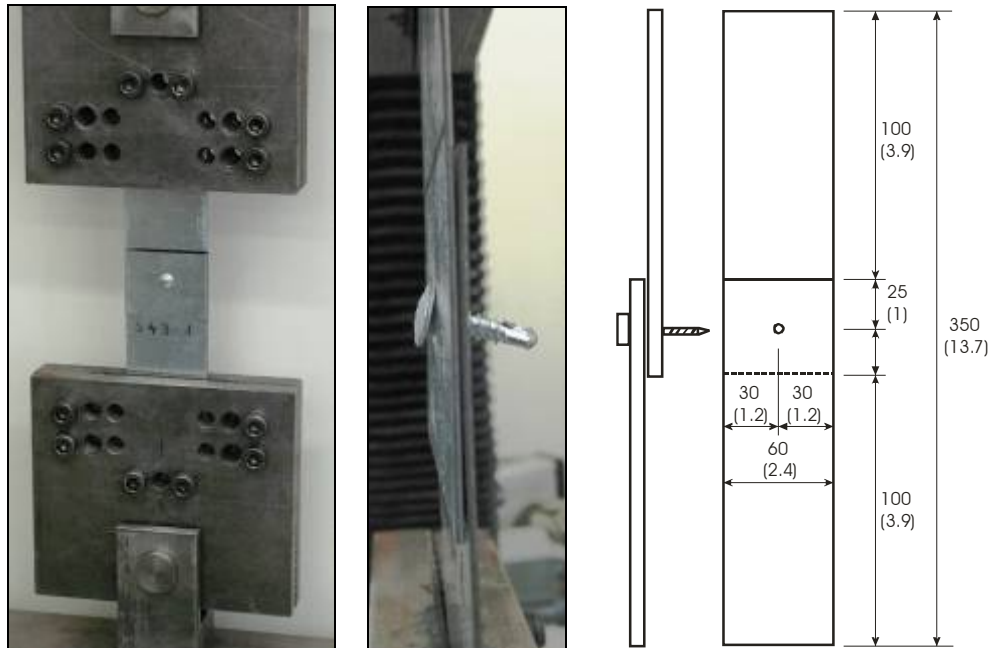

Figure F. 1 screw connection test settlement and schematics

Table F. 1 screw connection results

Test No.	Steel	Max. Capacity		Avg. Max. Capacity		Nominal Capacity	
		kN	kips	kN	kips	kN	kips
<i>bearing / tilting capacity</i>							
1	1.09mm (0.043") 230MPa (33 ksi)	3.92	0.88	4.16	0.93	5.36	1.21
2		4.31	0.97				
3		4.24	0.95				
1	1.37 mm (0.054") 340 MPa (50 ksi)	7.20	1.62	7.43	1.67	5.64	1.27
2		7.60	1.71				
3		7.50	1.69				
1	1.73mm (0.068"), 340 MPa (50 ksi)	8.00	1.80	8.23	1.85	6.90	1.55
2		8.50	1.91				
3		8.20	1.84				
<i>shear capacity</i>							
1	2.46 mm (0.097") 340 MPa (50 ksi)	7.90	1.78	8.00	1.80	-	-
2		7.70	1.73				
3		8.40	1.89				

APPENDIX G
HOLDDOWN POSITION

Figure G.1 to Figure G.3 represent the ratio of the recorded tension force in the holddown anchor rod F_{hd} to the lateral force S applied to the wall specimen during monotonic tests compared with the drift levels. It was assumed that the horizontal and the vertical component of the brace force are transferred to the tracks and chord studs respectively. During a test the vertical force is eccentrically applied to the anchor rod and the chord studs are slightly inclined due to the relative lateral movement of the top part of the wall which creates additional prying force at the anchor rod. The prying force depends on the lever arm which is difficult to estimate because it is different for the different wall configurations. As can be seen from the graphs this force is not significant at drift levels less than 3 % (the NBCC 2005 limits the drift levels to 2.5%) and thus prying action can be ignored in the design.

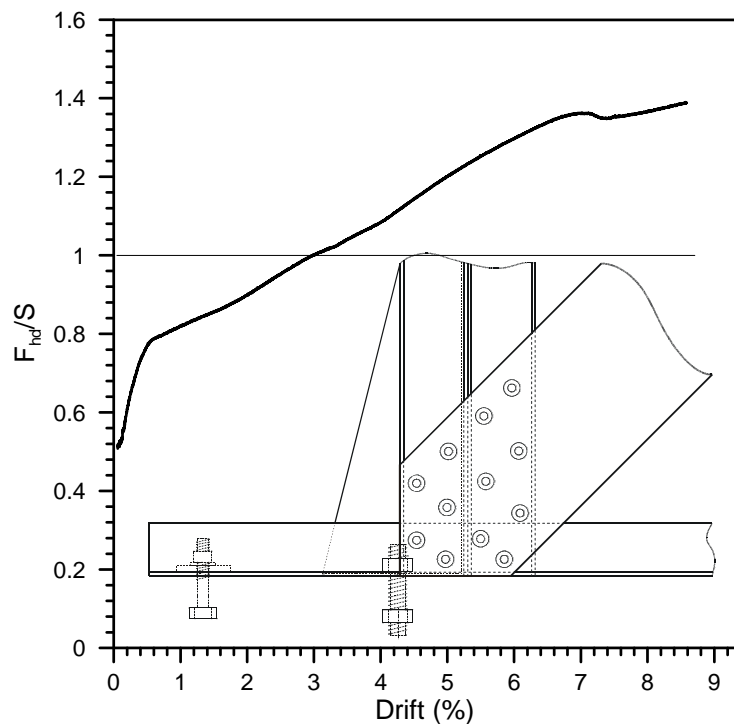

Figure G.1 Light wall configuration with holddown placed outside of the chord studs

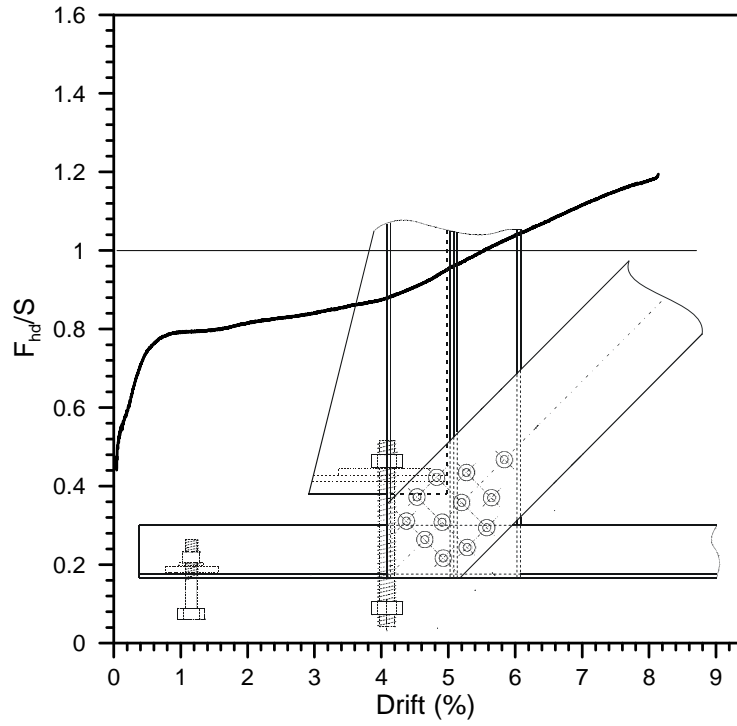

Figure G.2 Light wall configuration with raised holddown placed outside of the chord studs

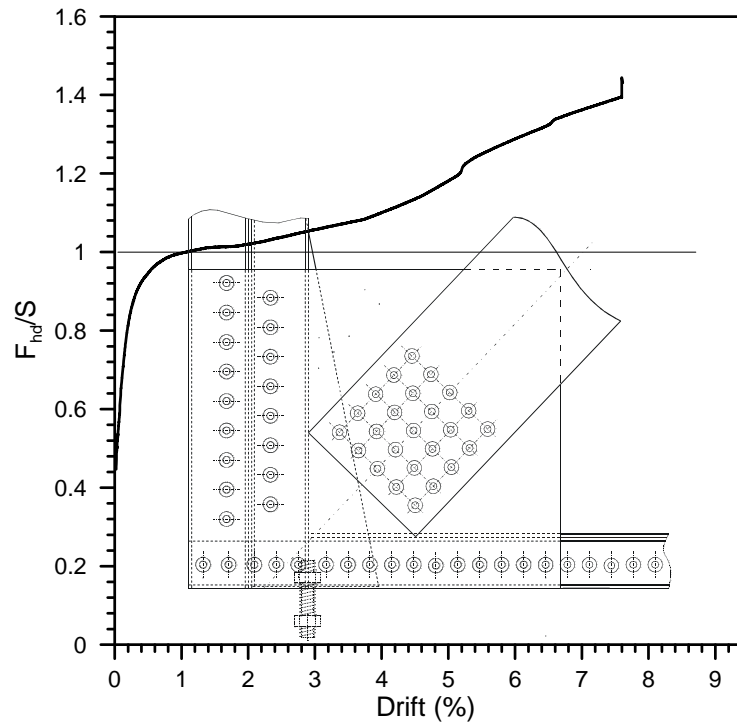

Figure G.3 Heavy wall configuration with holddown placed inside of the chord studs



American Iron and Steel Institute

1140 Connecticut Avenue, NW
Suite 705
Washington, DC 20036
www.steel.org



Steel Framing Alliance™

Steel. The Better Builder.

1201 15th Street, NW
Suite 320
Washington, DC 20005
www.steel framing.org

