

Overview of Recent Changes and Additions to AISI Standards

By Helen Chen¹, Roger Brockenbrough², Richard Haws³

Abstract

Since the publication of the 2007 editions of AISI standards, changes and additions have been made to some of the standards. This paper will provide an overview of the major revisions to those standards.

Introduction

During 2007, the American Iron and Steel Institute (AISI) Committee on Specifications and the Committee on Framing Standards have approved a series of design and testing standards, and established a new numbering system. A complete list of the published standards and the corresponding designated numbers is provided in Appendix A.

Among those standards, AISI S100-07, *North American Specification for the Design of Cold-Formed Steel Structural Members*, was developed and maintained by a joint effort of the AISI Committee on Specifications, the Canadian Standards Association Technical Committee on Cold Formed Steel Structural Members (S136), and Camara Nacional de la Industria del Hierro y del Acero (CANACERO). This Specification has been adopted in the United States by the American National Standards Institute (ANSI) as the American National Standards (ANS), in Canada by Canadian Standards Association (CSA) and endorsed by CANACERO in Mexico. AISI S100-07 has also been adopted by the International Building Code, 2009 edition, and NFPA 5000, Building Construction and Safety Code, 2009 edition.

¹ Manager, Construction Standards Development, American Iron and Steel Institute, Washington, DC.

² President, R. L. Brockenbrough & Associates, Pittsburgh, PA.

³ Technical Services Manager, NUCONSTEEL, Denton, TX.

The North American Cold-Formed Steel Framing Standards series (See Appendix A) were developed and maintained by the AISI Committee on Framing Standards and its subcommittees. These standards have been developed with the intent for adoption by North American countries, and have been approved by ANSI as American National Standards. All the North American Cold-Formed Steel Framing Standards listed in Appendix A, except AISI S202, have also been adopted by the International Building Code, 2009 edition, and NFPA 5000, Building Construction and Safety Code, 2009 edition.

Fourteen Test Standards (AISI S901-08 to AISI S914-08) have been published in the 2008 edition of the AISI *Cold-Formed Steel Design Manual* (AISI, 2008). Among these test standards, AISI S901-08 to AISI S912-08 were updated and reformatted, and AISI S913-08 and AISI S914-08 were newly developed. All the test standards have been approved by ANSI as the ANS as well.

In 2008, AISI published a new seismic design standard S110-07, *Standard for Seismic Design of Cold-Formed Steel Structural Systems – Special Bolted Moment Frames*. This standard provides design provisions for a single story moment frame formed by cold-formed channel beams and tubular columns. The cold-formed special bolted moment frames are intended to be used for free standing mezzanines (light storage), elevated office support platforms, equipment support platforms and small buildings in all seismic areas. The system is limited to a single story of 35 feet (10.7 m) maximum in height, with the ability to extend over several spans and multiple bay widths. All lateral resistance frame lines use the same sections for the beams and columns and all connections will be of the same geometry. As is the case with other AISI standards, this standard has been approved by ANSI as the ANS in 2008.

During 2009 and 2010, the following supplements were published:

- S100-07/S1-10, *Supplement No. 1 to North American Specification for the Design of Cold-Formed Steel Structural Members*;
- S100-07/S2-10, *Supplement No. 2 to North American Specification for the Design of Cold-Formed Steel Structural Members*;
- S213-07/S1-09, *North American Cold-Formed Steel Framing-Lateral Design with Supplement No. 1*; and

- S110-07/S1-09; *Standard for Seismic Design of Cold-Formed Steel Structural Systems – Special Bolted Moment Frames with Supplement No. 1*

Note that S100-07/S2-10 also includes the changes and updates made in S100-07/S1-09.

In the following sections, an overview is provided for major technical changes and additions that are included in these supplements.

Technical Changes and Additions in Supplements

1. S100-07/S2-10, Supplement No. 2 to North American Specification for the Design of Cold-Formed Steel Structural Members.

Supplements No. 1 and No. 2 were published in 2009 and 2010, respectively. The major changes are summarized as follows:

- (a) AISI S100 Section F1.1, Load and Resistance Factor Design and Limit States Design, is modified to recognize that the behavior and probability of failure for a composite interior partition wall stud differs from the direct load bearing system. A composite interior wall stud is a stud in an interior application with full-height gypsum sheathing that is screw attached to both flanges and supports, and no axial load other than self-weight. Instead of a safety factor (Ω) of 1.67 for lateral load resistance of load bearing wall studs, $\Omega = 1.5$ is used for lateral resistance of interior partition wall studs. This safety factor corresponds to a target reliability index $\beta_o = 1.6$. This low target reliability also reflects the fact that for composite interior partition wall studs, the consequences of failure are less severe than for other structural members. This change has been included in both Supplements No. 1 and No. 2.
- (b) AISI S213-07/S1, *North American Standard for Cold-Formed Steel Framing – Lateral Design, 2007 Edition with Supplement No. 1*, was adopted by the Canadian Standards Association. This standard is, therefore, recognized in the US, Mexico and Canada, and was referenced in AISI S100 Section A9, Referenced Documents.

- (c) For uniformly compressed elements with single or multiple identical and equally spaced stiffeners (AISI S100, Section B5.1.1), the buckling coefficient for local element buckling (k_{loc}) is revised to

$$k_{loc} = 4(b_o/b_p)^2 \quad (\text{AISI S100 Eq. B5.1.1-1})$$

where b_o = total flat width of stiffened element; b_p = largest sub-element flat width. This change results in a better estimate of member strength.

- (d) New provisions were added for cellular or composite decks (see Figure 1) with fastener spacing exceeding the requirements provided in AISI S100 Section D1.3, Spacing of Connections in Cover Plated Sections. The effective section properties of those composite decks can now be determined using newly added Section B2.5, Uniformly Compressed Elements Restrained by Intermittent Connections, and the strength of the section can then be determined according to the flexural member design provisions. The new provisions were developed based on the research work by Snow and Easterling (2008).

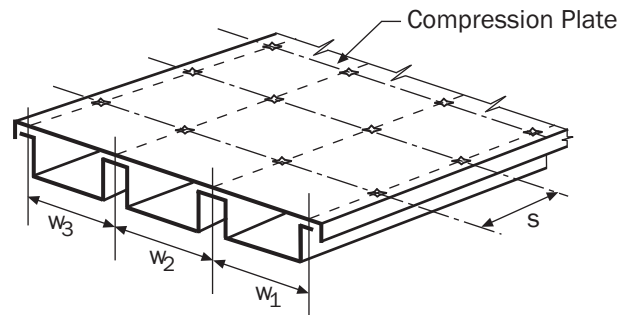

Figure 1 Built-Up Deck

- (e) The simplified provisions for considering distortional buckling of flexural and compression members have been moved from the Specification to the Commentary. This change is due to the consideration that even though the simplified approach can be useful to quickly determine that distortional buckling does not control the design, the approach is often overly conservative and could lead to some confusion to designers.

- (f) Tension Member Design Provisions for US and Mexico and Canada have been harmonized, and the provisions are now included in the main body of the Specification.
- (g) The resistance factor for sections with stiffened or partially stiffened compression flanges as defined in AISI S100 Section C3.1.1, has been changed from 0.95 to 0.90 for LRFD. This change is based on the examination of more recent available test data (Shafer and Trestain, 2002; Yu and Schafer, 2003), and consideration of the fact that the higher resistance factor existed in part due to inelastic reserve strength, which is addressed in AISI S100 Section C3.1.1(b).
- (h) In conjunction with the revisions of tension member design, significant changes and reorganizations were made to Chapter E, Connections and Joints. The complete chapter is included in Supplement No. 2. The major changes include:
- (1) The design provisions for flare bevel groove welds were revised. Two new equations were added to accurately define the effective throat of the groove bevel welds. Filled flush throat depths were also modified to match those specified in AWS D1.1-2006.
 - (2) The provisions for checking combined shear and tension on arc spot welds were added.

For ASD

$$\text{If } \left(\frac{\Omega_t T}{P_{nt}} \right)^{1.5} \leq 0.15, \text{ no interaction check shall be required.}$$

$$\text{If } \left(\frac{\Omega_t T}{P_{nt}} \right)^{1.5} > 0.15,$$

$$\left(\frac{\Omega_s Q}{P_{ns}} \right)^{1.5} + \left(\frac{\Omega_t T}{P_{nt}} \right)^{1.5} \leq 1$$

(AISI S100 Eq. E2.2.4.1-1)

For LRFD or LSD:

$$\text{If } \left(\frac{\bar{T}}{\phi_t P_{nt}} \right)^{1.5} \leq 0.15, \text{ no interaction check shall be required.}$$

$$\text{If } \left(\frac{\bar{T}}{\phi_t P_{nt}} \right)^{1.5} > 0.15,$$

$$\left(\frac{\bar{Q}}{\phi_s P_{ns}} \right)^{1.5} + \left(\frac{\bar{T}}{\phi_t P_{nt}} \right)^{1.5} \leq 1 \quad \text{For LRFD}$$

(AISI S100 Eq. E2.2.4.2-1)

where

Ω_t = Corresponding safety factor for P_{nt} given by AISI S100 Section E2.2.3

T = Required allowable tensile strength of connection

P_{nt} = Nominal tension strength as given by AISI S100 Section E2.2.3

Ω_s = Corresponding safety factor for P_{ns} given by AISI S100 Section E2.2.2

Q = Required allowable shear strength of connection

P_{ns} = Nominal shear strength as given by AISI S100 Section E2.2.2

\bar{T} = Required tensile strength [factored tension force] of the connection

= T_u for LRFD

= T_f for LSD

ϕ_t = Resistance factor corresponding to P_{nt} given in AISI S100 Section E2.2.3

P_{nt} = Nominal tension strength [resistance] as given by AISI S100 Section E2.2.3

P_{ns} = Nominal shear strength [resistance] as given by AISI S100 Section E2.2.2

\bar{Q} = Required shear strength [factored shear force] of the connection

= Q_u for LRFD

= Q_f for LSD

ϕ_s = Resistance factor corresponding to P_{ns} given in AISI S00 Section E2.2.2

The new provisions were developed based on research work at the University of Missouri-Rolla (predecessor of Missouri University of Science and Technology) (Stinemann, LaBoube, 2007).

- (3) For screws in tension, provisions for specific washer thickness are added. If the thickness of the sheet steel that is directly in contact with the screw head is less than 0.027 in. (0.69 mm), a washer a thickness of at least 0.024 in. (0.61 mm) must be provided; otherwise, if the thickness of the sheet steel is greater than 0.027 in. (0.69 mm), a washer thickness of at least 0.050 in. (1.27 mm) must be provided.
- (4) The tension and shear rupture design provisions for all the fasteners considered in the Specification are consolidated and included in Section 5.3, Rupture. The nominal tensile rupture strength, T_n , is defined as:

$$T_n = F_u A_e \quad (\text{AISI S100 Eq. E5.2-1})$$

where

$$A_e = \text{Effective net area subject to tension} \\ = U_{s\ell} U_{st} A_{nt} \quad (\text{AISI S100 Eq. E5.2-2})$$

where

$U_{s\ell}$ = Shear lag factor defined in Table AISI S100 Table E5.2-1

U_{st} = Staggered connectors factor

= 1.0 where staggered connectors are not present

= 0.9 where staggered connectors are present

A_{nt} = Net area subject to tension defined in AISI S100 Section E5.2.

AISI S100 Table E5.2-1
Shear Lag Factors for Connections to Tension Members

Description of Element	Shear Lag Factor, $U_{S\ell}$
(1) For flat sheet <i>connections</i> not having staggered hole patterns	
(a) For multiple connectors in the line parallel to the force	$U_{S\ell} = 1.0$
(b) For a single connector, or a single row of connectors perpendicular to the force	
(i) For single shear and outside sheets of double shear connections with washers provided under the bolt head and the nut.	$U_{S\ell} = 3.33 d/s \leq 1.0$ (AISI S100 Eq. E5.2-4)
(ii) For single shear and outside sheets of double shear connections when washers are not provided or only one washer is provided under either the bolt head or the nut.	$U_{S\ell} = 2.5 d/s \leq 1.0$ (AISI S100 Eq. E5.2-5)
(iii) For inside sheets of double shear connections with or without washers.	$U_{S\ell} = 4.15 d/s \leq 1.0$ (AISI S100 Eq. E5.2-6)
(2) For flat sheet <i>connections</i> having staggered hole patterns	$U_{S\ell} = 1.0$
(3) For other than flat sheet connections:	
(a) When load is transmitted only by transverse welds	$U_{S\ell} = 1.0$ and A_{nt} = Area of the directly connected elements
(b) When load is transmitted directly to all the cross sectional elements.	$U_{S\ell} = 1.0$
(c) For connections of angle members not meeting (a) or (b) above.	$U_{S\ell} = 1.0 - 1.20 \bar{x}/L \leq 0.9$ (AISI S100 Eq. E5.2-7) but $U_{S\ell}$ shall not be less than 0.4
(d) For connections of channel members not meeting (a) or (b) above.	$U_{S\ell} = 1.0 - 0.36 \bar{x}/L \leq 0.9$ (AISI S100 Eq. E5.2-8) but $U_{S\ell}$ shall not be less than 0.5

- (h) In the Direct Strength Design method, provisions are provided to permit applying the safety and resistance factors for pre-qualified members to non-qualified members. If a member falls outside the geometric and material limitations outlined in AISI S100 Table 1.1.1-1 for columns and Table 1.1.1-2 for beams, it is now possible to use the safety and resistance factors for pre-qualified members (i.e. those members with their geometric and material properties within the limitations). This is permitted if, through the use of AISI S100 Chapter F, the predicted resistance factor, ϕ , provides an equal or higher resistance factor compared to the resistance factor for pre-qualified members. In the use of AISI S100 Chapter F, $P = \text{Test-to-predicted ratio}$; $P_m = \text{Mean of test-to-predicted ratio}$; $V_p = \text{Coefficient of variation of } P$. If $V_p \leq 15\%$, C_p is permitted to be set to 1.0. At least three tests should be conducted.

2. S213-07/S1-09, North American Cold-Formed Steel Framing-Lateral Design with Supplement No. 1

This standard has been revised and updated in 2009 with the following major changes:

- a. The definition of “amplified seismic load” was added. “Amplified seismic load” is defined as “Load determined in accordance with the *applicable building code* load combinations that include the system overstrength factor, Ω_o , for strength design (LRFD). [USA and Mexico].”
- b. The ductility-related force modification factor, R_d , for diagonal strap braced walls has been adjusted to match the values approved by the Canadian National Committee on Earthquake Engineering (CANCEE) for inclusion in the National Building Code of Canada (NBCC) seismic provisions.

**Design Coefficients and Factors for Seismic Force Resisting Systems in Canada
(Excerpt from AISI S213 Table A4-1)**

Type of Seismic Force Resisting System	R_d	R_o	Building Height (m) Limitations ¹				
			Cases Where $I_E F_a S_a(0.2)$				Cases Where $I_E F_v S_a(1.0)$
			< 0.2	≥ 0.2 to < 0.35	≥ 0.35 to ≤ 0.75	> 0.75	> 0.3
Diagonal Strap Braced (Concentric) Walls							
Limited ductility braced wall	1.9	1.3	20	20	20	20	20
Conventional construction	1.2	1.3	15	15	NP	NP	NP

- c. Based on the research work at the University of North Texas (Cheng, 2009), new shear wall nominal shear strengths for wind and other in-plane loads were added for 0.027 in. (0.69 mm) one side steel sheet with height to width aspect ratio 2:1.

**Nominal Shear Strength (R_n) for Wind and Other In-Plane Loads for Shear Walls
for US and Mexico (Pounds Per Foot)
(Excerpted from AISI S213 Table C2.1-1)**

Assembly Description	Maximum Aspect Ratio (h/w)	Fastener Spacing at Panel Edges (inches)			
		6	4	3	2
0.027" steel sheet, one side	4:1	-	1,000	1085	1170
	2:1	647	710	778	845

- d. The setback requirements have been revised. It is required that where setbacks of structural walls create an offset between them on an upper and lower story, the floor diaphragm and floor framing shall be designed to transfer overturning and shear forces through the offset in accordance with AISI S213 and the applicable building code.
- e. The equations for design deflection of a blocked wood structural panel diaphragm for US Customary and SI units are consolidated into one expression.

3. S110-07/S1-09, Standard for Seismic Design of Cold-Formed Steel Structural Systems-Special Bolted Moment Frames with Supplement No. 1

To have the system adopted by ASCE 7, a series of analyses were performed following FEMA P-695 (FEMA, 2009). It was concluded from the analyses that the system would performance well with the following seismic performance factors.

Design Coefficients and Factors for Basic Seismic Force Resisting Systems							
Basic Seismic Force Resisting System	Response Modification Coefficient R	System Overstrength Factor Ω_0	Deflection Amplification Factor C_d	Height Limit (ft)			
				Seismic Design Category			
				B & C	D	E	F
Building Frame Systems							
Cold-formed steel–special bolted moment frames ^c	3.5	3.0 ^a	3.5 ^b	35	35	35	35

^a The seismic load effect with overstrength, E_{mh} , is permitted to be based on the expected strength determined in accordance with AISI S110, Section D1.2.3.

^b Also see AISI S110 Section D1.3.

^c Cold-formed steel–special bolted moment frame is limited to one-story in height.

The values included in the table above are consistent with what has been adopted in ASCE 7-09 (ASCE, 2009).

References

American Iron and Steel Institute (2008), *Cold-Formed Steel Design Manual, 2008 Edition*, Washington, DC, 2008.

American Society of Civil Engineers (2009), *ASCE/SEI 7-09, Minimum Design Loads in Buildings and Other Structures*, Reston, VA, 2009.

Snow, G. L. and Easterling, W. S. (2008). "Section Properties for Cellular Decks Subjected to Negative Bending." Report No. CE/VPI - 08/06. Virginia Polytechnic Institute and State University, Blacksburg, VA, 88 pages.

Schafer, B.W., Trestain, T. (2002). "Interim Design Rules for Flexure in Cold-Formed Steel Webs." *Proceedings of the Sixteenth International Specialty Conference on Cold-Formed Steel Structures*, Orlando, FL. 145-160.

Yu, C., Schafer, B.W. (2003). "Local Buckling Tests on Cold-Formed Steel Beams." *ASCE, Journal of Structural Engineering*. 129 (12) 1596-1606.

FEMA, (2009), P695, "Qualification of Building Seismic Performance Factors," June, 2009.

Stirnemann, L.K., R. A. LaBoube (2007), "Behavior of Arc Spot Weld Connections Subjected to Combined Shear and Tension Forces," Research Report, University of Missouri-Rolla, Rolla, MO, 2007

Appendix A: AISI Standards and Designations

New Designation	Old Designation	Title
AISI S100	NASPEC	North American Specification for the Design of Cold-Formed Steel Structural Members
AISI S110	SEISMIC	Standard for Seismic Design of Cold-Formed Steel Structural Systems-Special Bolted Moment Frames
AISI S200	GP	North American Cold-Formed Steel Framing - General Provisions
AISI S201	PRODUCT	North American Cold-Formed Steel Framing - Product Data
AISI S202	COSP	North American Cold-Formed Steel Framing - Code of Standard Practice
AISI S210	FRSD	North American Cold-Formed Steel Framing - Floor and Roof System Design
AISI S211	WSD	North American Cold-Formed Steel Framing - Wall Stud Design
AISI S212	HEADER	North American Cold-Formed Steel Framing - Header Design
AISI S213	LATERAL	North American Cold-Formed Steel Framing - Lateral Design
AISI S214	TRUSS	North American Cold-Formed Steel Framing - Truss Design
AISI S230	PM	North American Cold-Formed Steel Framing - Prescriptive Method
AISI S901	TS-1	Rotational-Lateral Stiffness Test Method for Beam-to-Panel Assemblies
AISI S902	TS-2	Stub-Column Test Method for Effective Area of Cold-Formed Steel Columns
AISI S903	TS-3	Standard Methods for Determination of Uniform and Local Ductility
AISI S904	TS-4	Standard Test Methods for Determining the Tensile and Shear Strength of Screws

(Continue)

AISI S905	TS-5	Test Methods for Mechanically Fastened Cold-Formed Steel Connections
S907	TS-7	Test Standard for Cantilever Test Method for Cold-Formed Steel Diaphragm
S908	TS-8	Base Test Method for Purlins Supporting a Standing Seam Roof System
S909		Standard Test Method for Determining the Web Crippling Strength of Cold-Formed Steel Beams
S910		Test Method for Distortional Buckling of Cold-Formed Steel Hat Shaped Compression Members
S911		Method for Flexural Testing Cold-Formed Steel Hat Shaped Beams
S912		Test Procedure for Determining a Strength Value for a Roof Panel-to-Purlin-to-Anchorage Device Connection
S913		Test Standard for Hold-Downs Attached to Cold-Formed Steel Structural Framing
S914		Test Standard for Joist Connectors Attached to Cold-Formed Steel Structural Framing