

FIRE PROTECTION THROUGH MODERN BUILDING CODES

FIFTH EDITION

AMERICAN IRON AND STEEL INSTITUTE

FIRE PROTECTION THROUGH MODERN BUILDING CODES

FIFTH EDITION

by

Delbert F. Boring, P.E.
James C. Spence, P.E.
Walter G. Wells, P.E.

1981

AMERICAN IRON AND STEEL INSTITUTE
WASHINGTON, D.C.

First Edition, December 1944
Second Edition, March 1950
Third Edition, April 1961
Third Edition, April 1963 (Second Printing)
Fourth Edition, November 1971
Fourth Edition, March 1978 (Second Printing)
Fifth Edition, October 1981

The data, regulations, specifications, architectural/engineering information and drawings presented in this publication have been delineated in accordance with recognized professional principles and practices, and are for general information only. Suggested provisions should not, therefore, be used without first securing competent advice with respect to their suitability for any given application. The publication of the material contained herein is not intended as a warranty on the part of American Iron and Steel Institute—or that of any other person named herein—that these data are suitable for any general or particular use, or of freedom from infringement of any patent or patents. Any use of these data or suggested practices can only be made with the understanding that American Iron and Steel Institute makes no warranty of any kind respecting such use and the user assumes all liability arising therefrom.



Copyright © 1981 by American Iron and Steel Institute
All Rights Reserved
Manufactured in the United States of America
Library of Congress Catalog Card Number: 81-69487

PREFACE

This is the Fifth Edition of FIRE PROTECTION THROUGH MODERN BUILDING CODES. Many years' study of the myriad problems associated with the formulation and application of building code regulations have given it its present shape and substance.

The First Edition, published in 1941, was conceived and authored by Bertram L. Wood and James A. Schad, members of AISI staff, after considerable research and study of building codes and fire protection regulations then in use. Subsequent editions of the book were prepared and edited by members of the Institute's Engineering Division Staff.

This Fifth Edition has a new format and has been extensively revised to reflect many new concepts found in current fire protection requirements and regulations. It is again the product of members of the Engineering Division Staff, including Delbert F. Boring, James C. Spence and Walter G. Wells. Herbert W. Eisenberg, AIA, provided assistance and guidance in developing the reorganization and new format for the book as well as offering numerous suggestions concerning the practical application of modern building code provisions.

In the course of writing the several editions of this book, extensive reference has been made to the building construction and fire-protection standards published by these organizations: American Society for Testing and Materials, American Insurance Association, American National Standards Institute, National Bureau of Standards, and National Fire Protection Association. Careful review was made of the building codes sponsored by the Building Officials and Code Administrators International, the International Conference of Building Officials, the American Insurance Association, the Southern Building Code Congress International, and the Associate Committee on the National Building Code of the National Research Council of Canada, as well as the building codes of many cities. These have been instrumental in developing the various discussions and regulations.

To the many building officials, architects, engineers and members of

the organizations cited, acknowledgement and sincere appreciation are gratefully expressed. It would be difficult, if not impossible, to list the many professional and technical organizations and individuals who gave generously of their time and talent. To all these we extend profound thanks.

R. Thomas Willson
Senior Vice President-Engineering and Promotion
American Iron and Steel Institute

INTRODUCTION

Revision and modernizing of building code regulations so that they may take into account the advances and new techniques in construction technology has been a continuous concern of many members of the building industry for over four decades. Further, there is acceptance of the need to subject regulatory requirements to continuous study and reassessment in order to keep pace with the changing modes of building construction.

Regulations introduced in building codes many years ago were based on the materials and practices then in vogue and which experience had shown to be safe. Many such empirically derived regulations were repeated without question from code to code and thus assumed greater authority as time passed, although lacking technical substantiation. As changes came about in building materials and construction methods, many regulations became inapplicable or unduly restrictive.

The continued use of outmoded precepts acts as a strong deterrent to the development of a progressive, economically sound, efficient construction technology. Moreover, these dated rules may require the continuation of building methods that are totally unsuited to modern needs. Thus, in the interests of recognizing technological development and enhancing human safety, all building professionals and concerned public officials must contribute to the continuing effort needed to modernize building codes.

As early as 1938, American Iron and Steel Institute, recognizing the compelling need for code reforms, organized a Committee on Building Codes. This group was directed to study existing building regulations and to undertake a variety of research studies and other activities, all of which were to be focused on the problem of providing sound and rational building code regulations.

From its inception, this committee and its successors have been engaged in studies of building standards and codes for cities, counties, states and other jurisdictions in order to determine the underlying

purpose behind each code regulation and how each actually affects life and fire safety. In many instances, research, tests, surveys and other investigations have been made to supplement existing information. As new concepts are developed from research, they are made available on a continuing basis to building officials and to building professionals. Such information is, in fact, made freely accessible to anyone who serves on code-writing committees or who may otherwise have an interest in better regulations for the building construction industry.

Thus American Iron and Steel Institute provides a continuous flow of up-to-date, code-related information to aid the ongoing process of building code renewal and revision. It is hoped that the correlation of available data will lead to clearer and more realistic thinking in the preparation of building code regulations relative to fire protection. Only by a thorough understanding of the fundamental criteria governing fire behavior and life safety from fire can uniform and reasonable requirements be derived.

This book consists of discussions and analyses of fire protection regulations having the greatest significance and broadest general interest. Not incidentally, these regulations are also those most in need of constant review and revision. The central issues covered are fire severity, fire hazards relating to occupancies, building size, structural fire protection and means of egress.

Previous editions of this book contained a complete set of fire protection regulations formulated from study of various codes and standards and intended to illustrate the principles discussed in the text.

In this edition, fire protection regulations are not included and requirements of model codes and recommendations of code writing organizations are cited in the text. The regulations cited are from the following sources:

- Basic Building Code of the Building Officials and Code Administrators International (BOCA)
- National Building Code of the American Insurance Association (AInsA)
- Standard Building Code of the Southern Building Code Congress International (SBCCI)
- Uniform Building Code of the International Conference of Building Officials (ICBO)
- National Building Code of Canada of the Associate Committee on the National Building Code, National Research Council of Canada
- The recommendations of the Board for the Coordination of the

Model Codes (BCMC) of the Council of American Building Officials (CABO), the Model Codes Standardization Council (MCSC) and the building codes of several cities and other jurisdictions have also been used as sources.

Fire research programs, studies and surveys sponsored by American Iron and Steel Institute, experience gained through service and participation on committees responsible for national building and fire-protection standards, and liaison with many code-writing groups have also provided much supportive data.

Much progress has been made in building construction techniques and in materials development since the publication of the First Edition in 1944. While this Fifth Edition reflects that progress, it adheres to its original purpose to help develop construction standards for safeguarding life and property from fire.

FIRE PROTECTION THROUGH MODERN BUILDING CODES

CONTENTS

CHAPTER	PAGE
PREFACE	iii
INTRODUCTION	v
LIST OF TABLES	xvii
LIST OF ILLUSTRATIONS	xix
1. BUILDING CODES—THEIR BACKGROUND AND PURPOSE	1
Background of Building Regulations	1
Technological Advances	3
Model Codes.....	4
Model Codes Standardization Council.....	6
Council of American Building Officials.....	6
—National Research Board	7
—Board for the Coordination of the Model Codes ..	7
—One and Two Family Dwelling Code	7
The Use of Standards in Building Codes.....	8
Summary	9
References	9
2. FIRE SAFETY OBJECTIVES	11
Concepts of Fire Safety Regulations in Building Codes	12
Safety for Building Occupants	15
Panic	17
Safety of Firemen	19
Safety to Adjoining Property.....	20
Prevention of Property Loss.....	21
Summary	23
References	24
3. FIRE RESISTANCE AND FIRE SEVERITY	25
History of Early Fire Endurance Testing	26
The 1918 Standard Fire Test Method	28

3. FIRE RESISTANCE AND FIRE SEVERITY (Cont'd.)

Development of the Fire Load Concept	31
Contemporary Fire Research	36
Design of Fire Resistant Buildings	40
Fire Test Standards and Model Building Codes	44
Summary	44
References	45

4. OCCUPANCY CLASSIFICATION AND HAZARDS..... 49

Determination of Occupancy Classifications	49
Mixed Occupancies	50
Occupancy Change	51
Potential Fire Severity and Hazards of Occupancies ...	52
Occupancy Classifications	53
Assembly Occupancies	53
—Combustible Contents	54
—Characteristic Hazards to Occupants	55
Business Occupancies	56
—Combustible Contents	56
—Characteristic Hazards to Occupants	57
Educational Occupancies	58
—Combustible Contents	59
—Characteristic Hazards to Occupants	60
Factory-Industrial Occupancies	61
—Combustible Contents	61
—Characteristic Hazards to Occupants	62
Hazardous Occupancies	62
Institutional Occupancies	64
—Combustible Contents	64
—Characteristic Hazards to Occupants	65
Mercantile Occupancies	66
—Combustible Contents	66
—Characteristic Hazards to Occupants	67
Residential Occupancies	67
—Combustible Contents	67
—Characteristic Hazards to Occupants	68
Storage Occupancies	70
—Combustible Contents	70
—Characteristic Hazards to Occupants	71
Utility and Miscellaneous Use Occupancies	71

4. OCCUPANCY CLASSIFICATION AND HAZARDS (Cont'd)

Special Occupancy Requirements	71
—Automobile Parking Structures	71
—Exhibition Halls.....	73
—Covered or Enclosed Malls.....	73
—Buildings for High-Stacked and Rack Storage	74
Summary	75
References	76

5. EGRESS FROM BUILDINGS

Means of Egress—Definition	78
Exit Capacity	78
Escalators and Elevators	82
Exit Arrangement—Separation and Travel Distance ...	83
Dead-End Corridors	84
Number and Design of Exit Facilities	85
Exterior Exits.....	86
Smokeproof Towers	86
Horizontal Exits.....	87
Egress from Tall Buildings	88
Exit Details	89
Summary	90
References	91

6. CLASSIFICATION OF BUILDINGS BY TYPES OF CONSTRUCTION

Construction Classifications in the Model Codes	93
Model Codes Standardization Council	
Classifications	96
Classifications of Building Types	99
—Type I Construction (Fire-Resistive).....	99
—Type II Construction (Noncombustible).....	103
—Type III Construction (Exterior Protected Combustible)	103
—Type IV Construction (Heavy Timber).....	104
—Type V Construction (Wood Frame).....	107
Mixed Types of Construction	107
Summary	108
References	108

7. FIRE ENDURANCE OF BUILDING CONSTRUCTION AND MATERIALS	109
The Standard Fire Test	110
—Fire Exposure.....	114
—Restrained and Unrestrained Classifications.....	118
—Walls and Partitions	119
—Columns.....	122
—Beams and Girders	126
—Trusses	127
—Floor and Roof Construction.....	129
Elevated Temperature Properties of Steel	130
Fire Protection Materials	135
—Gypsum	137
—Spray-Applied Materials.....	137
—Concrete.....	138
—Masonry.....	139
Architecturally Exposed Steel.....	139
Summary	146
References	147
8. PREVENTION OF INTERIOR SPREAD OF FIRE	151
Protection of Vertical Openings	151
Fire Walls or Area Separation Walls	153
Fire Resistive Interior Walls and Partitions	153
Openings in Interior Walls or Partitions.....	154
Interior Finish	156
Firestopping.....	158
Ducts.....	159
Penetrations of Fire-Resistive Assemblies	160
High Rise Buildings	161
Buildings Without Windows	163
Basements and Cellars	164
Furnace and Boiler Rooms	164
Chimneys and Vents	165
Automatic Fire-Extinguishing Systems.....	165
—Recognition of Automatic Sprinklers as Alternate Protection	166
Standpipes.....	168
Summary	168
References	169

9. EXTERIOR WALLS AND ROOF AND THE PREVENTION OF FIRE SPREAD	171
Exterior Wall Requirements in the Model Building	
Codes	171
Thermal Radiation and Building Separation	172
Minimum Separation Distances and Limits on	
Unprotected Openings	175
Protection of Openings in Exterior Walls	184
Fire Resistance Requirements for Non-Load Bearing	
Exterior Walls	184
Fire Resistance Requirements for Load Bearing	
Exterior Walls	185
Party Walls, Fire Walls and Parapets	185
Vertical Spread of Fire	188
Roof Coverings	191
Summary	191
References	192
10. BUILDING SIZE LIMITS—HEIGHTS AND AREAS	195
General Principles of Building Size Limitations	195
Height and Area Limits in Existing Building Codes ..	196
A Rational Approach to Building Area Limits	200
Area Limits for Multistory Buildings	202
Area Increase for Accessible Building Perimeter	204
Area Increase for Automatic Fire-Extinguishing	
Equipment	205
Buildings of Unusually Large Area	206
Building Height Limits	207
—Low-Rise Buildings	207
—Intermediate-Height Buildings	207
—High-Rise Buildings	208
Height Allowances for Sprinklered Buildings	208
Height Limits for Low Hazard Occupancies	209
Summary	209
References	210
GLOSSARY	211
APPENDIX	217
INDEX	227

LIST OF TABLES

TABLE	PAGE
1. Principal Structural Defects Influencing Fire Spread In Building Fires with Property Damage of \$250,000 or More	22
2. Relationship Between Fireload and Fire Endurance	34
3. Classification of Building Occupancies	50
4. Fire Loads in Assembly Occupancies.....	54
5. Derating Factors to Determine Combustible Contents of Steel Furniture.....	57
6. Profile of Office Fire Loads, General and Clerical Offices—Sample size = 1044 offices	58
7. Fire Loads in Educational Occupancies	59
8. Fire Loads in Institutional Occupancies	65
9. Fire Loads in Residential Occupancies	69
10. Occupancies—Fire Load—Fire Severity	75
11. Building Occupancy Density.....	81
12. Capacity of Exits Per 22 Inch Unit Width	82
13. Types of Construction And Their Fire Safety Characteristics—National Building Code of Canada	95
14. Classification of Buildings by Type of Construction—Comparison of Model Building Codes Using MCSC Notation System.....	97
15. Model Codes Standardization Council Recommended Types of Construction	98
16. Fire Resistance Requirements For Structural Elements (Hrs.)	100-101
17. Recommended Nominal Dimensional Requirements For BCMC Type IV (2HH) Construction	105

18. Construction Classification, Restrained and Unrestrained	120-121
19. Classification of Openings in Fire Resistive Walls and Partitions	155
20A. Maximum Area of Unprotected Openings in Exterior Walls (Percentage of Exposing Building Face) for Group A, B, E, F2, I, R, S2 Occupancies	178-179
20B. Maximum Area of Unprotected Openings in Exterior Walls (Percentage of Exposing Building Face) for Group H, F1, M, S1 Occupancies	180-181
Notes to Tables 20A & 20B: Spatial Separation and Exposure Protection of Buildings	182
21. Fire Resistance Requirements for Exterior Walls (Hrs.).	186
Notes to Table 21	187
22. Basic Allowable Heights and Areas for Business, Educational and Residential Occupancies in Three Model Codes (Heights in Stories/Feet, Areas in Square Feet).....	198-199
23. Area Limits for Multistory Buildings, Basic Building Code—1981	203

LIST OF ILLUSTRATIONS

FIGURES	PAGE
1a. Fire losses through the years.	12
1b. Per capita fire losses in the United States.	13
2. Time-temperature curve from "Standard Methods of Fire Tests of Building Construction and Materials" (ASTM E119-80).	30
3. A comparison between time-temperature curves used in structural fire testing in various countries.	32
4. Average time-temperature curve reported by Ingberg for a record storage area.	33
5. The "fire severity" concept.	35
6. Furnace cool down curves reported by Ingberg for various standard fire endurance times.	36
7. Determination of equivalent fire endurance time. ISO Technical Report 3956.	37
8. Effect of window area on fire temperatures during burnout tests with natural ventilation.	39
9. Effect of fire load on temperature recorded during burnout tests with forced ventilation.	40
10. Characteristic time-temperature curves for various fire loads and an intermediate opening factor, as developed by Lie and Stanzak, AISC Engineering Journal, Vol. 13, No. 2, 1976.	41
11. Characteristic time-temperature curves for various opening factors and a fire load of 4.1 psf, as developed by Lie and Stanzak, AISC Engineering Journal, Vol. 13, No. 2, 1976.	42
12. Typical fire exposure conditions for exterior elements. ISO International Standard 834.	43

FIGURES

13.	Plan and section of a typical furnace for conducting standard fire tests, which is used for determining ratings of floor and ceiling assemblies.	111
14.	Comparative time-fuel input curves.	117
15.	The effect of mass on column fire endurance.	123
16.	Determination of the heated perimeter of structural steel columns.	124
17.	Fire resistance of structural steel columns protected by various thicknesses of gypsum wallboard.	125
18.	Determination of the heated perimeter of structural steel beams.	127
19.	Stress-strain curves for an ASTM A36 steel, developed by Harmathy and Stanzak, ASTM STP 464.	132
20.	Modulus of elasticity of ASTM A36 structural steel at elevated temperatures.	133
21.	Tensile strength of ASTM A36 structural steel at elevated temperatures.	134
22.	Yield strength of ASTM A36 structural steel at elevated temperatures.	135
23.	Temperature of top and bottom flanges of protected steel beams during exposure to ASTM E119 Standard Fire Test.	136
24.	Exterior column with architecturally exposed steel column covers.	140
25.	Schematic arrangement of fire-protection system for liquid-filled columns.	141
26.	Steel temperatures in a liquid-filled column during exposure to fire.	143
27.	Fire-resistive flame shielding on spandrel girder of "One Liberty Plaza" building in New York City.	144
28.	Average furnace and exterior steel spandrel temperatures during burnout and 3-hour standard fire tests.	145
29.	Flame patterns during the two fire tests on flame shielded spandrel girder.	145

30.	Because radiation scatters, intensity varies with the size and shape of the radiator and decreases with increasing distance from the heat source.	173
31.	The effect of shape of exposing building face on distance separation. The five buildings have the same area of building face. The greater radiation intensity at a fixed distance for the more nearly square radiating wall is evident.	174
32.	Dimensions for determining spacial separation between structures.	176
33.	Assumed and actual shape of flames projecting from windows with vertical separation of openings.	189
34.	Assumed and actual shape of flames projecting from windows with horizontal projections between openings. .	190

CHAPTER 1

BUILDING CODES THEIR BACKGROUND AND PURPOSE

Building construction has always been the result of compromises between the temporary and the enduring; the hastily built and the craftsmanship of the skilled; the expedient and the thorough. Laws to regulate building construction are the result of the recognition that public welfare is served by requiring buildings to be constructed safely using the best available knowledge and practice. The need for regulating building construction in the interest of safety and health has been felt in many times and places wherever men have lived under urban conditions.

Background of Building Regulations

Evidence of regulation is found in the Code of Hammurabi which dealt with the hazards from faulty construction in Babylon about 2250 B.C. Early Greek and Roman laws had the objective of confining loss of life from a building collapse to one property. They included provisions for control of materials of construction, size of buildings and inspection of construction. After many fires plagued ancient Rome, where multi-story wood buildings were built in great clusters, laws were passed to control construction by regulating the density to which structures might be built.

As a result of the serious fires which occurred periodically in London in the Middle Ages, numerous laws to control construction were enacted. These laws included a ban on thatch roofs and required existing thatch roofs to be replaced with tile roofing. Chimneys were required to be constructed of stone, tile, or plaster instead of timber. After disastrous fires in 1664 and 1666, regulations were enacted that specified not only the kinds of construction to be used but the locations where each type was permissible. Regulations also governed timber sizes, thickness of walls, and the number of stories to which a building could be built. In addition, inspectors or "surveyors" were appointed

to enforce the provisions. Penalties for violations included sentencing the offender to jail.

Records of the settlements in North America also indicate that building regulations were adopted early in their history. In the 1630's Plymouth, Massachusetts required thatched roofs to be changed to boards or palings, chimneys to be carefully constructed and homeowners to have a ladder reaching to the top of the roof. Similar regulations were enacted in neighboring towns.

The laws of Hartford, Connecticut demanded a ladder or tree reaching within two feet of the top of the roof of each building. The owner could be fined five shillings for each month this means of access was lacking.

During the planning of our national capital, George Washington listed a number of items to be considered in relation to the construction of private buildings. In addition to suggested limitations on the height of buildings, President Washington seriously questioned the construction of wooden buildings within the city because of their potential conflagration hazard. The District Commissioners adopted the first official building regulations in 1791, limiting wood frame structures to a height of twelve feet (3.7 m) and an area not exceeding 328 square feet (30.5 m²).

Frequently quoted are the rules of the Moravian community of Wachovia, now Salem, North Carolina. In 1788, the Town Council developed and approved a set of regulations governing both planning and construction. The philosophy and scope of the regulations was stated as follows:

“We are not going to discuss here the rules of the art of building as a whole, but only those rules which relate to the order and way of building in our community. It often happens due to ill-considered planning that neighbors are molested and sometimes even the whole community suffers. For such reasons in well-ordered communities rules have been set up. Therefore, our brotherly equality and the faithfulness which we have expressed for each other necessitates that we agree to some rules and regulations which shall be basic for all construction in our community so that no one suffers damage or loss because of careless construction by his neighbor and it is a special duty of the town council to enforce such rules and regulations.”

The regulation went on to provide that building shall be done by masters who would be responsible to the community if damage occurred due to their negligence. Permission to construct a house would be granted only after the applicant could satisfy the community of his ability to pay for the work. Other specific requirements included

approval of the plan and suitability of the house lot, proper separation of fireplaces from combustible material, and location of stovepipes, ovens and smokehouses. An administrative procedure to ensure proper enforcement was also described.

Technological Advances

A significant step was taken in New England in the mid-1800's. While fire had destroyed many poorly constructed or poorly managed textile mills, some mills were built, and managed, to high safety standards. Their managers and engineers found that the insurance companies at that time were not interested in "risk improvement." To avoid paying for serious fire losses that were occurring in some mills over which they had no control, mill owners formed mutual insurance companies whose members agreed to maintain certain levels of fire safe design and fire prevention procedures thus qualifying for less costly insurance coverage.

These companies found that experimentation with methods of construction and fire-protection devices, particularly with automatic sprinkler systems that were just beginning to be developed, produced worthwhile results.

The activities of these mutual insurance companies led to the formation of Factory Mutual Laboratories in 1886 and Underwriters Laboratories, Inc. in 1894. Each provided facilities for testing fire protection devices and equipment. The outcome of this early testing resulted in criteria and standards not only for general building design but also for fire-protection systems installed in buildings. Other associations and organizations were started and some municipalities developed their own standards for fire-protection equipment and devices. However, the lack of uniform national standards was a serious weakness in achieving the sought after level of fire protection.

The 1904 Baltimore conflagration provided evidence of the need not only for uniform standards but also for building regulations to minimize the occurrence of such catastrophic fires. This fire reached such proportions in its first hours that urgent appeals for aid were sent not only to neighboring cities but to more distant cities such as Philadelphia, New York, and Washington, D.C. as well. Apparatus and men were sent to Baltimore, but much of the apparatus could not be used because hose couplings used by these other cities would not fit the Baltimore hydrants. Before being finally contained, the fire swept over 140 acres or 80 blocks and destroyed about 2500 buildings.

In the following year, 1905, the National Board of Fire Underwriters published a "model" code in an effort to standardize building regulations.

In the ensuing years, municipal codes proliferated as the need for building construction regulations became more widely recognized. In the report of the Select Committee on Reconstruction and Production of the U.S. Senate published in 1921, it was pointed out that building code requirements in the United States varied widely and were a source of unnecessary high costs in construction. Since that time various writers and authors have repeated these charges and have also charged codes with lack of flexibility in dealing with new materials and methods of construction. Much of the criticism was justified at that time. Clearly, an effort was needed to obtain uniformity in building codes.

In 1939 the National Bureau of Standards published a report "Preparation and Revision of Building Codes," BMS 19, to assist communities in writing building codes. It suggested a standardized code arrangement, the use of nationally developed standards, and provisions to permit acceptance of new materials and construction methods. Much of this information remains valuable even today.

Today, the interest in local drafting of building codes has all but disappeared due to the complexities of maintaining a document which of necessity is so broad in scope and in need of constant revision. Today, there is almost nationwide acceptance of the principle of using a model building code. The need for continual updating, the wealth of expertise available to the model code groups, and the advantages to the building industry of broadly accepted uniform requirements, have made the practice of drafting codes locally undesirable and unnecessary.

Model Codes

Model building codes have gained wide recognition throughout the United States. These codes have been developed by organizations whose members have a wealth of experience in the building regulatory field.

The first model code in the United States was prepared by representatives of the fire insurance industry in response to the serious losses from conflagrations that occurred in cities across the country. Boston, New York, Chicago, Baltimore, and San Francisco all suffered devastating fires in the late 1800's. The National Board of Fire Underwriters, now American Insurance Association (AInsA), deeply concerned by these

enormous fire losses, developed a recommended building code whose primary purpose was to reduce fire hazards and the loss from fire. Called the National Building Code, this set of comprehensive building regulations was suitable for adoption as law by municipalities and established a basic pattern for the development of building codes throughout the country. This first model code has been revised and republished numerous times since it was first published in 1905. The most recent revision of the National Building Code is the 1976 Edition. In 1980, responsibility for the maintenance of the National Building Code was transferred to the National Conference of States on Building Codes and Standards.

In 1927, the Pacific Coast Building Officials Conference, now the International Conference of Building Officials (ICBO) drafted and adopted the first edition of the Uniform Building Code at its sixth annual meeting. The code has gained wide acceptance throughout the country, particularly in the west. It was the first model code to establish distinct fire resistance rating requirements for specific types of construction. The ICBO processes revisions to the Uniform Building Code annually and publish new editions every three years.

The Southern Building Code Congress, Int. (SBCCI) was organized in 1945 by building officials and inspectors from the southern part of the United States. The SBCCI first published the Southern Standard Building Code in 1946. Now known as the Standard Building Code, it is revised annually and new editions are published every three years.

The Building Officials and Code Administrators, International (BOCA), founded in 1915 as the Building Officials Conference of America, first published its model code, the Basic Building Code, in 1950. Revised editions of the code are published every three years and code revisions are considered every year. The Basic Building Code has gained wide acceptance in many states and municipalities in the United States, largely in the north and east.

The three building officials' organizations that publish model building codes process their code changes by an open process. Opportunity for public participation at hearings is provided and action on proposed changes is by vote of member building officials representing local and state jurisdictions.

The National Building Code of Canada was developed and is maintained by the Associate Committee on the National Building Code of the National Research Council of Canada. The members of the Associate Committee are appointed by the National Research Council and

represent all interests of the building construction industry in Canada. First published in 1941, revised editions of the National Building Code of Canada were published every five years until 1975, and every two years since. The code, although voluntary, is widely adopted by municipal, provincial and other government agencies of Canada. Its background and concepts have been developed almost entirely in Canada and its approach to many fire protection matters is quite different from model code practice in the United States. For that reason alone it is a valuable resource document for code researchers.

Model Codes Standardization Council

Although the format of the model building codes are not alike, the differences in code principles that have existed have diminished over the years.

Much of the effort to eliminate the differences in the codes was coordinated by the Joint Committee on Building Codes (JCBC) organized in 1949. The membership of JCBC included voting representatives from the American Insurance Association, American National Standards Institute, American Society for Testing and Materials, Building Officials and Code Administrations International, International Conference of Building Officials, National Bureau of Standards, National Fire Protection Association, Southern Building Code Congress International, Underwriters Laboratories, Inc., the U.S. Department of Housing and Urban Development, and the National Research Council of Canada. In 1959 the Joint Committee was reorganized as the Model Codes Standardization Council (MCSC) and representatives of the design professions participated as advisory members on a non-voting basis. In 1970 the membership was again expanded and representatives of the construction industry were also included as advisory members.

The initial purpose of the Joint Committee was to identify and resolve differences in the model codes without necessarily changing code format or style. Over the years the MCSC developed recommendations on building code definitions, occupancy classifications, and types of construction. The MCSC's recommendations generally have been recognized by the model building code groups, resulting in much greater uniformity.

Council of American Building Officials

Recognizing the need for a forum to coordinate the efforts of the model code organizations at the national level by research to develop

improved building regulations, BOCA, ICBO and SBCCI organized Council of American Building Officials (CABO) in 1972. CABO is composed of Boards of Directors of the three organizations with the technical and educational staffs of each organization providing support of its activities. The major activities of CABO include the National Research Board, the Board for the Coordination of the Model Codes and the One and Two Family Dwelling Code Committee.

National Research Board—The National Research Board administers a uniform building products and systems research program for the benefit of CABO members and the building industry. Applications for recognition of products and systems are reviewed by the technical departments of CABO members, and those judged to meet the acceptance criteria of the model codes are issued a national research report which describes the use and application of the product or system.

Board for the Coordination of the Model Codes—The Board for the Coordination of the Model Codes reviews and recommends resolution of differences between the model codes and related standards. The Board has representation from each member organization of CABO and works through committees to develop recommendations on a variety of subjects. These have included code provisions for means of egress, definitions, pile foundations, occupancy classifications, types of construction, covered malls, heights and areas and others where conflicts may exist between the model codes.

The Board also evaluates new technology or concepts not contained in current model codes and develops, where appropriate, recommendations for new regulations.

After developing and publishing its recommendations, the Board conducts public hearings and then reports its findings to the CABO Board of Directors for approval before processing them through each model code organization's code change process.

One and Two Family Dwelling Code—The One and Two Family Dwelling Code developed by the members of CABO in cooperation with the American Insurance Association is a nationally recognized model code designed to provide code officials and builders with a specification for the construction of one- and two-family dwellings. This specification type code is especially useful for those not having the

technical background necessary for interpretation of the more performance oriented provisions of the model codes.

To continue the maintenance and further development of the One and Two Family Dwelling Code, CABO has established a consensus committee composed of building officials, home builders, architects, engineers, fire officials and testing authorities. Following a consensus process the committee holds public hearings on all new code revisions on an annual basis. New editions of this code are published every third year.

The Use of Standards in Building Codes

Codes and standards have similar but separate functions. Codes are usually broader in scope and include in their framework references to many standards. Codes usually are intended to become mandatory regulations either through direct legislative action or through the administrative authority delegated by legislation.

Standards are generally considered to be a set of conditions or requirements to be met by a material, product, process or procedure. Standards may also describe a method of testing to determine physical, functional or performance characteristics of materials or products.

The technical bases of most building regulations are the standards which are referenced in the body of the code. There is a great deal of uniformity in building codes as a result of their reference to nationally recognized standards.

Most national standards are developed by voluntary standards writing organizations. These organizations follow procedures for standards development designed to obtain a national consensus of all groups affected by the standards including consumers, producers, designers, government, and independent experts. There are numerous standards writing organizations and nearly 2,000 of their standards are referenced in U.S. building codes.

Standards referenced in building codes can generally be classified as materials standards, engineering practice standards, and testing standards.

Materials standards generally establish minimum requirements of quality as measured by composition, mechanical properties, dimensions, and uniformity of product. They include provisions establishing methods of sampling and testing for verification of such quality.

Engineering practice standards include basic design procedures, engineering formulas, and special provisions intended to provide a

satisfactory level of performance. As in the case of materials standards, engineering practice standards may be sufficiently comprehensive to include methods of testing to verify performance. An example might be a structural design specification which includes provisions limiting its application to materials meeting certain levels of quality and strength, and also providing for the testing of structural assemblies whose performance must be evaluated on that basis.

Testing standards generally pertain to the methods and procedures employed to establish levels of quality or performance of materials or assemblies. Included are procedures for measuring such characteristics as structural strength and stability, permeability, durability, combustibility, and fire resistance.

Citing standards by reference in building codes serves to reduce the length of the code document but it should be recognized that the referenced standard must be available to the building public and should be kept on file by the building official. Most organizations that publish standards make them available to code authorities at little or no cost.

Summary

Building regulations in some form can be identified among the earliest traceable records of cities. They were and remain today a distinctive feature of local governments. Simple and limited in objective at first, regulations have become far more comprehensive in the last 75 years and regulate all the major aspects of building design, especially those factors relating to fire safety. This development has in large measure been a result of the formation of organizations of persons whose profession is the application of such codes to building design and construction as well as those directly concerned with the enforcement of such codes. The model code organizations have recognized the merits of standardization and uniformity and the development of more consistency in building codes. Much of this has come about by the recognition of nationally recognized consensus standards that are applicable to materials, testing and design.

References

AMERICAN INSURANCE ASSOCIATION, *National Building Code*, 1976 Ed., New York, NY, 1976.

ASSOCIATE COMMITTEE ON THE NATIONAL BUILDING CODE, *National*

Research Council of Canada, *National Building Code of Canada*, 1980 Ed., Ottawa, Ontario, Canada, 1980.

BUILDING OFFICIALS AND CODE ADMINISTRATORS INTERNATIONAL, *Basic Building Code*, 1981 Ed., Chicago, IL, 1981.

COUNCIL OF AMERICAN BUILDING OFFICIALS, *One and Two Family Dwelling Code*, Third Ed., Alexandria, VA, 1979.

INTERNATIONAL CONFERENCE OF BUILDING OFFICIALS, *Uniform Building Code*, 1979 Ed., Whittier, CA, 1979.

NATIONAL BUREAU OF STANDARDS, *Preparation and Revision of Building Codes (BMS 19)*, Washington, D.C., May 1939 - Revised (BMS 116), Sept. 1949.

NATIONAL FIRE PROTECTION ASSOCIATION, *Fire Protection Handbook*, 14th Ed., Boston, MA, 1976.

—*National Fire Codes*, published annually, Boston, MA.

—*Life Safety Code (NFPA No. 101)*, Boston, MA, 1980.

SANDERSON, R.L., *Codes and Code Administration*, Building Officials Conference of America, Inc., Chicago, IL, 1969.

SOUTHERN BUILDING CODE CONGRESS INTERNATIONAL, *Standard Building Code*, 1979 Ed., Birmingham, AL, 1979.

FIRE SAFETY OBJECTIVES

The basic objectives of fire protection regulations are to safeguard life and property. In general, these objectives are achieved in buildings by providing a safe means of escape or a safe refuge for the occupants in the event of a fire, by designing the building to limit the progress and spread of fire and smoke if one starts, and by providing fire-detection and extinguishing equipment or systems. The function of the building code is to prescribe the minimum fire-safety and protection requirements for the building, including exit facilities and the fire detection and extinguishing systems.

In the early stages of a fire, when occupants must be quickly evacuated so that fire fighting can begin, interior fire safety is of prime importance. If the initial extinguishment efforts are ineffective, proper building design will significantly reduce the possibility of fire spread to adjacent parts of the building or to other buildings. It is essential that fire-protection design features be maintained in proper balance so that there is an adequate assurance of protection from the many contingencies a fire may present. A building code should be so written that minimum acceptable design requirements are stipulated for all structures.

The objectives of building code regulations governing fire protection are, in order of importance, as follows:

1. To provide for the safety of occupants of buildings, and to make provision for their evacuation or refuge during a fire or other emergency.
2. To provide for the safety of firemen fighting a fire.
3. To provide for the safety of adjoining property and to prevent the spread of fire.
4. To provide for the preservation of the property itself.

Many building design features have a distinct effect on more than one of the four objectives listed above. Those that have the most direct

relationship to life safety are discussed in this chapter. Features concerned with reducing the spread of fire in interiors are examined at greater length in Chapter 8. Design aspects applicable to the safety of adjacent property are discussed in Chapter 9.

Concepts of Fire Safety Regulations in Building Codes

In developing building regulations for fire safety, many code writers have attempted to use fire-loss statistics as a basis for justifying more and more restrictive regulations. This rationale can be deceptive. As with any other set of statistical data, fire-loss statistics can be interpreted so as to rationalize almost any hoped-for conclusion. For example, dollar losses resulting from fire are rising yearly, and reportedly they now exceed \$3 billion per year. These are only the reported losses and do not include either the far larger nonrecoverable losses or the long-term losses that accrue from major interruptions to business operations. On the other hand, since such figures neither take into account the

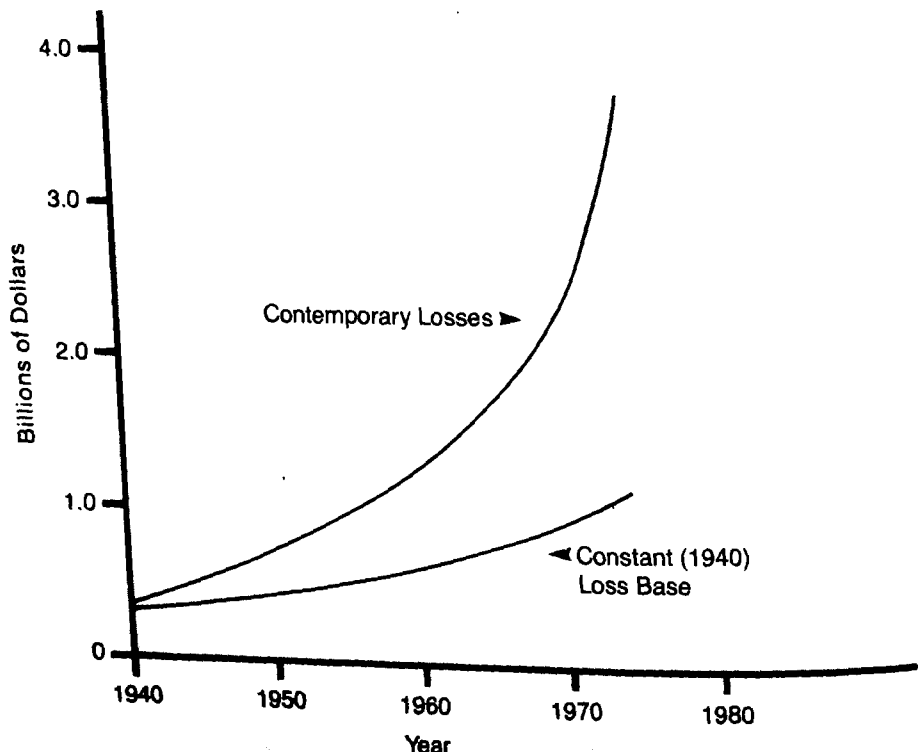

Figure 1a. Fire losses through the years. NFPA Handbook, 14th Edition.

effects of inflation nor reflect the fact that in each succeeding year there is more of value to burn, the actual annual fire losses cannot be determined or compared.

Figures 1a and 1b from the National Fire Protection Association's Fire Protection Handbook, 14th Edition, 1976, show the effects of inflation on the reported dollar fire loss and per capita fire loss. The adjusted loss figure shows very little rate of increase in the total fire loss or per capita loss. These figures, however, offer small comfort to those who actually suffer from severe fire losses.

Over the last two decades the number of fire deaths per million persons in the United States has been declining steadily, dropping from 69.5 per million population in 1955, to 55.4 fire deaths per million population in 1975. However, the United States still has the highest fire death rate of any industrialized nation.

Over a 35-year period, 17,892 fires were reported to the National Fire Protection Association (NFPA). These accounted for 47,165

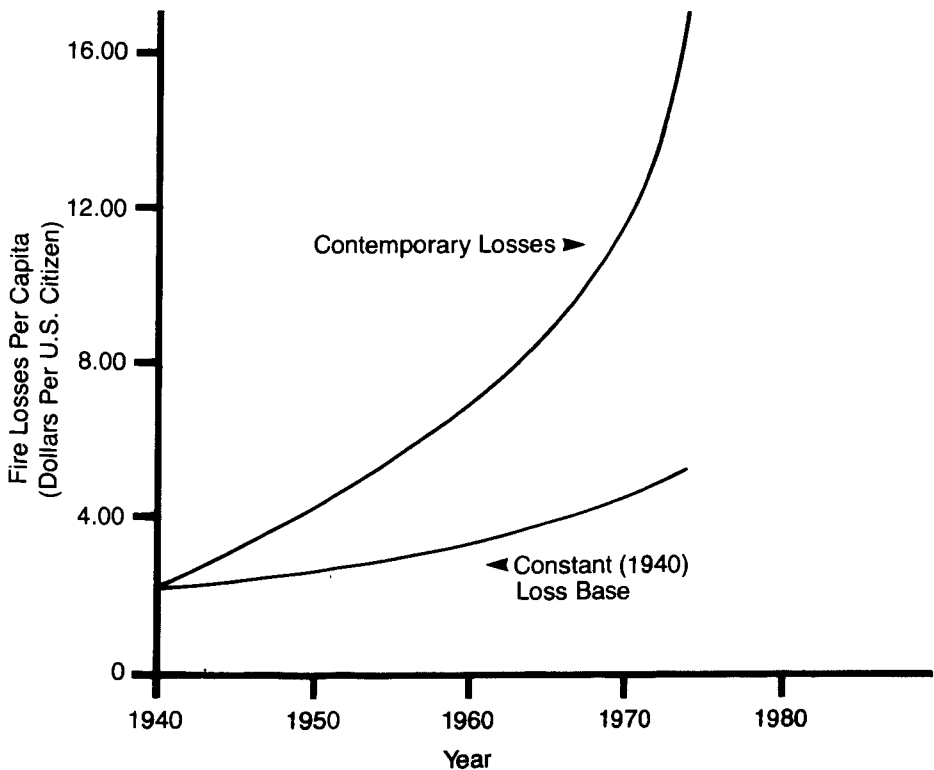

Figure 1b. Per capita fire losses in the United States. NFPA Handbook, 14th Edition.

deaths, a number that represents about ten percent of the total fire fatalities for the period in question. In the NFPA data, 17,445 deaths (36 percent) occurred in dwellings. Yet dwellings are subjected to the least stringent regulations in building codes. They are, of course, the place where people spend the most of their time, but few have seriously proposed that fire-safety regulations should be based on the ratio of man-hours anticipated for each occupancy to the man-hours of total time in which all buildings are occupied.

More important than a straightforward compilation of fire loss data is a scientific investigation of why fires start, why they spread, what factors contribute to loss of life and property, and what measures must be taken to reduce the likelihood of a serious fire. These are the determinants for establishing realistic fire-safety requirements in building codes.

If it were feasible to eliminate all fuel from building construction by using only fire-resistive or noncombustible materials and assemblies and by limiting the combustible contents of buildings, the hazard of fire would be greatly reduced. But since this is an unlikely possibility, it is necessary to apply restrictions and regulations to building construction that will provide reasonable safety for the public by reducing fire and conflagration hazards as much as is practical.

There is a tendency to identify a single set of conditions as the causative factor, although in actuality it is more often a multiplicity of circumstances that leads to a major fire, a large number of fatalities, or both. Many fires can be controlled through the enactment and enforcement of suitable building regulations governing contributing factors to fire spread and fire loss. These include quantity and distribution of combustible materials and their relation to the type of building construction, the size of the building itself, combustibility of interior finish, location of fire doors, enclosure of vertical openings, design and installation of mechanical and electrical equipment, adequacy of exit facilities, installation of automatic fire suppression systems and accessibility to fire-fighting forces.

While much study and analysis of fires have focused on the features of building design, this work is usually confined to isolated problems. Valuable as such data may be, this kind of investigatory procedure does not recognize a building's design features, the behavior characteristics of its occupants, or the nature of its combustible contents taken as a whole. It seems apparent that the concept of properly applied systems analysis, so effective in other disciplines, may contribute a great deal to

the understanding of fire behavior in buildings: how fires develop and spread, and how effective building requirements would be in limiting such spread. The fire problem is certainly not under control. There is still a great need for additional data and re-analysis of available data to refine existing and proposed building regulations.

Safety for Building Occupants

The factors responsible for smoke and fire spread in 500 typical fires that resulted in fatalities have been summarized in the NFPA Fire Protection Handbook (14th Edition).

The principal contributory factor to the loss of life in fires, according to these data, is the rapid and often undetected fire spread through vertical shafts or other concealed spaces.

A stairway, elevator shaft, or similar opening between floors will, if not enclosed, act as a flue during a fire and thereby spread hot gases, smoke, and flames throughout the building. To prevent fire spread from one story to another, all vertical openings must be enclosed or fire-stopped. Where vertical openings are necessary, they must be separated from the rest of the building by fire-resistive construction. Openings required for mechanical and electrical services should be fully enclosed in noncombustible construction, or all open space remaining after the installation of pipes, ducts, or equipment must be fully sealed at every floor level with approved fire-stopping materials. Firestopping must not be neglected—it can reduce the hazard of fire spread within concealed spaces.

The hazard of rapid spread of fire through a building is substantially reduced when the structural members are of noncombustible materials. Since they will not act as fuel, the hazard from fire originating within the construction itself or behind its protective covering is eliminated. However, where combustible materials are used the hazard of fire spread can be reduced by the effective use of firestopping and blocking at every floor level.

Fire spread within a building can also be prevented or minimized by protecting structural members, to prevent collapse from the effects of fire; by eliminating fuel within structural assemblies; by subdividing the building into limited areas through the use of fire-resistive walls, floors and doors; and by enclosing vertical openings with fire-resistive construction. Restrictions on interior finish materials with respect to combustibility and rate of flame spread also add significantly to fire and life safety conditions in buildings.

Most deaths are the result of smoke and gas inhalation, not exposure to flames. Taking as an example the study of 500 typical fires summarized in the NFPA Handbook, 62 percent of the fatalities were attributed to asphyxiation or anoxia caused by inhalation of smoke and fire gases.

The degree of hazard to life, both from smoke and fire gases and from panic, increases as the time needed by the occupants to escape from the fire area increases. Once a fire is detected and the alarm given, the speed with which evacuation can be completed will depend in great measure upon the distance that occupants must travel in order to reach properly designed exits.

Exit requirements are among the most important code regulations that directly affect the safety of building occupants during a fire or other emergency. The number of persons assumed to be within a building or floor area is calculated from an assumed density in square feet per person. Different occupancies may have different density figures. The type and number of facilities needed to evacuate a building within a reasonable period of time are also dependent on the kind of occupancy, the maximum number of persons assumed to be within the building and, in multi-story buildings, their distribution among the different levels.

The various considerations for proper exit regulations are discussed in Chapter 5. Many of these were derived from studies originally reported in Miscellaneous Publication, M151, of the National Bureau of Standards, "Design and Construction of Building Exits" (1935). The exit regulations included in most codes are based mainly upon the recommendations developed in these studies and upon recommendations developed as a result of fire experience. Regulations have also been modified and expanded over the years to take into account new concepts of construction and design practices, particularly where newer types of occupancies have developed, such as the shopping mall. Some basic studies to determine how exit facilities are actually used has been done since the 1935 report was issued, but the data obtained have yet to be reduced to workable code provisions.

Chapter 5 of the Life Safety Code of the National Fire Protection Association, NFPA 101, contains detailed regulations for building exits including specific requirements for doors, door hardware, stairs, ramps, escalators, handrails and guards. Provisions for practically all of these components are included in the model codes, though there are some differences in details.

Other requirements for exit design deal with interior finish, protection of vertical openings, automatic detection and signaling systems, and automatic fire extinguishing systems.

Provisions that will permit the handicapped to have access to buildings are beginning to be included in building codes. Regulations for life safety for handicapped occupants will also need to be considered.

Panic

No discussion of fire and life safety in buildings would be complete without noting regulations designed to minimize the danger of panic. In all probability, this potential danger cannot be totally eliminated, but the conditions which give rise to panic can be reduced by proper attention to design details that will facilitate rapid, orderly egress.

The concept of panic, although not fully understood, is characterized by the irrational and uncontrolled behavior of an individual or group exposed to a threatening situation, whether real or imaginary. Frequently, in the case of fire, "panic is assumed to be a highly emotional automatic response to noxious stimuli," such as the smell of smoke or the sight of flames.

The conditions which bring people to the psychological state of panic are not well defined; however, elements at the scene which are likely to contribute include the physical features of the occupied facility, the temperament of the occupants, and possibly the influence of toxic gases on the exposed occupants behavior. Features of the facility which allow the occupants to make an escape with a minimum of hindrance during an emergency will lessen the likelihood of panic. At the same time, however, the benefit of properly designed exit facilities can be cancelled out if the temperament of the occupants is such that they ignore these features as might be the case in a night club, at a rock concert or during a sports event. In a situation where the occupants are not exposed to the fire, yet not free to evacuate, the psychological state of the individual might gradually be altered due to simply increasing fear of the unknown or the influence of toxic gases present in the atmosphere.

The approach taken by the building code authorities is to examine the physical features of the building with regard to how they might influence evacuation of the facility during an emergency. Adequate exits, strategically placed, visibly marked, well illuminated, and open to regular use, provide a sense of security to the occupants and thus lessen the chance of panic.

Overcrowding of facilities, especially places of assembly unfamiliar to the occupants, is too frequently one of the factors leading to panic in an emergency. This fact was well demonstrated by the Coconut Grove Night Club fire in 1942 where it was estimated over a thousand people were packed into a facility designed to hold 600, and more recently by the Beverly Hills Supper Club fire (1977) where approximately 1250 were present in a room with a recommended capacity of 536. For this reason it is important that capacity limitations be assigned to the facility and strictly adhered to.

Another factor recognized as contributing to the likelihood of panic is a fire that spreads rapidly creating the illusion, if not the reality, of entrapment. Frequently this characteristic of a fire can be attributed to the use of quick-burning materials in the form of decorations and interior finishes, and furnishings. There is continuing research and study on the fire behavior of materials used for these purposes in order to provide the basis for appropriate provisions in the building codes.

One final comment on panic. A general alert whenever a fire is detected, while always recommended by safety officials, is not always observed by the managers of public assembly occupancies, hotels or similar occupancies. Management may argue that the very act of announcing a fire emergency may itself provoke a panic. Further, minor incidents may occur frequently enough so that alarms may tend to be ignored. Prompt alert of the building occupants in the event of a fire will provide the maximum amount of time needed for safe evacuation and thereby lessen the potential for panic resulting from the effects of fire. In the case of the Beverly Hills Supper Club fire, it is reported that twenty minutes elapsed between the time the fire was discovered and the time a public announcement was made. In that interval the safe evacuation of all the occupants could conceivably have taken place.

There may be no general answers to the problem of minimizing panic once a fire is discovered and has the potential for spreading or trapping persons. A far better course is to design buildings so that these life threatening situations cannot happen. Just as important is individual education such that it becomes common knowledge of the best actions one must take and urge others to take in event of fire. The "solution" to the panic problem is as much a responsibility of the individual occupant of a building as it is of the designer and manager.

Adequate exits, strategically placed, marked for visibility, and used wherever possible as both entrances and exits, will not only provide the means for a rapid evacuation but will, because of their known presence,

impart a sense of security and thus lessen the possibility of panic. The number of building occupants, particularly in an assembly occupancy where generally crowded conditions prevail, tends to increase the possibility of panic.

These considerations should be included in the preparation of suitable provisions for life safety in building construction for every occupancy. They have a special importance not only to the design of exit facilities but also in determining limits that are to be placed on various features of construction such as interior finish.

An examination of the various features and conditions that cause panic would suggest, for example, that any and all quick-burning material, e.g., decorations and interior finish, be eliminated, and that all exits be maintained in a well-marked, uncluttered, and safe condition.

Safety of Firemen

While the building design can have an important effect on the operations of the fire service during fire emergencies and disaster calls, firemen cannot be expected to provide total protection for the occupants of a building and the property itself.

The building code must have provisions to aid fire fighting operations, which may be broadly described as occupant protection and rescue, fire suppression, and salvage and overhaul activities. In order to rescue occupants trapped in a building and start fire suppression operations, access to the building, and the fire area in particular, is a crucial factor. Code provisions limit the areas of buildings between fire resistive walls and other barriers, and control total fire areas according to the amount of access provided. Access to the interior of buildings can be complicated by the fact that occupants evacuating the building are moving in a direction opposite to that of the firemen attacking the fire. The code must provide for clearly marked means of egress that can be easily recognized during an emergency, so that occupants can leave as quickly as possible and fire fighters can reach the area of fire origin.

Even minor fires can produce tremendous amounts of smoke and gas and their removal is an important firefighting operation. Code provisions related to smoke removal most commonly deal with access panels, movable windows, skylights, or other types of readily opened devices in case of a fire emergency. Emergency controls on mechanical systems to prevent them from distributing smoke or gases to uninvolved areas of the building are also required by building codes.

The effectiveness of fire department operations decreases rapidly as the height of a building increases. Modern codes now provide special regulations for highrise buildings making automatic sprinklers or building compartmentation mandatory. Walls, ceilings, and interior surfaces in the areas to be compartmented are strictly controlled to limit the amount of combustibles and to prevent the spread of fire both vertically and horizontally. Special ventilation may be provided to further protect the compartmented areas.

The requirements for standpipes, sprinklers, and other fire fighting equipment to be included in the building are part of a modern building code, but the specific design requirements such as capacities, size of pipe, and other data are contained in reference standards published by NFPA and manufacturers of sprinkler systems.

Recent advances in the development of detection devices, particularly smoke detectors, have been recognized by the model code groups, and the use of detectors is now required by most codes for residential occupancies including one and two family dwellings. Early warning is a significant factor for the safety of occupants and the control of fire. Fires are more easily extinguished in their early stages and the more promptly people can be alerted to a fire the better are the chances for their safe escape. Where there are facilities available, a detection system can be connected to a central station or to the fire department so that response will not be delayed.

Safety to Adjoining Property

Apart from structural safety, the original impetus for developing building code regulations was to prevent the spread of fire from the building of origin to other buildings. The safety of the community is endangered every time fire spreads beyond the limits of the structure in which it originates, thereby threatening to become a conflagration.

Conflagrations in the nineteenth and early twentieth centuries devastated many U.S. cities and were responsible for the development of many special fire regulations governing building construction. The first model building code in the U.S., the National Building Code, was developed with the concept of preventing fire spread to adjoining property by specifying heavy masonry wall construction for almost all types of buildings. The behavior of buildings involved in fire is much better understood now and modern codes provide for lighter, less costly but more effective means of fire containment and control.

The term "conflagration" is used in describing fires that extend over

a considerable area and involve the destruction of large numbers of buildings. It is also used to describe fires that cross natural and protected barriers such as streets and fire walls. The NFPA Fire Protection Handbook, 14th Edition (Table 1-5F), lists 27 factors contributing to conflagrations in the United States and Canada which occurred from 1900 to 1967. Conflagrations are seldom due solely to any one factor and the NFPA summary indicates the number of fires to which each factor has contributed rather than listing a single factor for each fire. Most of the factors are related to each other. The six most prominent factors listed by NFPA are: unusually hot or dry weather conditions, inadequate public protection, lack of exposure protection, inadequate water distribution system, high winds, and wood-shingle roofs.

The NFPA Handbook points out that “inferior and combustible construction is the predominant factor in the development of conflagrations.....”

It is virtually impossible to entirely eliminate the combustibles from construction or building contents. Nonetheless, it is possible to devise regulations that will help to confine a fire to a single building or its area of origin. The intensity of a building fire must remain below the level that would cause ignition of exposed combustibles on or in other buildings. Providing adequate separation distance between buildings and limiting the size and number of openings in the exterior wall both will control the level of heat exposure on adjacent construction. For these factors to remain effective, the exterior wall must have sufficient fire resistance to withstand the potential burnout of the building’s combustible construction and contents. These same factors, separation distance, extent of wall openings, and the fire resistance of exterior walls, also limit the spread of fire to a building from an external source.

The separation distance between buildings will determine the allowable proportion of window openings in the walls. As the separation between buildings increases, the need to protect an adjacent building against fire and heat diminishes. If the space between buildings is great enough, protection need only consist of measures necessary to protect any exposed exterior structural members from the interior fire.

Prevention of Property Loss

The fire resistance of the structure is a major factor in the protection of property. This is particularly true where vertical spread of fire may occur. The possibility of containing or suppressing a fire diminishes when two or more floors are involved.

A tabulation of factors responsible for fire spread in buildings which resulted in property damage of \$250,000 or more has been prepared by NFPA and appears as Table 1-5A in the Fire Protection Handbook, 14th Edition. Only public assembly, mercantile, industrial, manufacturing, and storage occupancies are included. While more than one factor may have been identified in some fires, the majority of the total number of factors in the seven categories involved the use of combustible framing and finish (39.4 percent) and non-fire-stopped areas (43.4 percent). The factors are included in Table 1.

Table 1—Principal Structural Defects Influencing Fire Spread in Building Fires with Property Damage of \$250,000 or More

Factor	Times Reported	Percent
Vertical Spread		
Stairways or other open shafts	47	7.5
Non-fire-stopped walls	31	5.0
Horizontal Spread		
Non-fire-stopped areas including floors and concealed spaces above or below floors and ceilings.	240	38.4
Interior wall openings, unprotected	31	5.0
Exterior finish	29	4.7
Combustible Framing/Finish		
Structure or Framing	224	36.0
Ceilings, walls, floors	21	3.4
	<u>623</u>	<u>100.00</u>

The data presented in this table give no indication of the construction types of the buildings involved beyond the identification of combustible framing.

To assure the preservation of a building's structural integrity during a fire, construction should be noncombustible and possess fire resistance equal to or greater than the fire severity represented by the building contents. If there is inadequate structural fire protection, or if there is a possibility that the structural members will ignite and burn in a fire, the building area and height should be limited to reduce the hazard represented by the building construction.

Criteria for building height and area limits are developed in detail in

Chapter 10. At this point it will suffice to say that height and area should be related in terms of the aggregate fire load that may be exposed to a single fire. Where the fire protection may not be sufficient to withstand a fire, an appropriate upper limit to the aggregate fire load or building area is warranted.

If the building itself will not burn, the potential fire hazard will be greatly reduced. Other factors being equal, there is less danger of fire spreading rapidly beyond its incipient stage in noncombustible buildings. Therefore, allowable heights and areas should be greater for noncombustible structures than for combustible structures, particularly in occupancies with moderate or low fire loads.

In a non-fire-resistive structure, the aggregate quantity of all combustibles in both structure and contents may create an uncontrollable fire unless the height and area are restricted. Inside such a building, fire fighting may not be possible, and the less effective procedure of attacking the blaze from outside may be the only alternative.

Summary

The purpose of building code regulations is to minimize the loss of life and property resulting from fire. Although statistics on fire occurrence and behavior are often used to support certain code regulations or the need for them, reliance on these data alone can only indicate where to look for more fundamental fire behavior criteria that may be addressed in building codes.

Principal building design factors that will enhance life safety are proper exit design, elimination of fast burning wall and ceiling finishes, facilities that will aid in prompt detection and extinguishment of fire and provisions that will minimize the spread of fire from building to building. Use of noncombustible construction components eliminate many potential sources of fire and avenues for fire spread.

Fire severity is ultimately determined by the amount of combustible material exposed to a single fire source. Building construction, the kind of occupancy and the building's size are the dominant design features that determine the amount of combustibles. Proper code provisions attempt to balance all these factors.

References

- AMERICAN NATIONAL STANDARDS INSTITUTE, *Specifications for Making Buildings and Facilities Accessible to, and Usable by, the Physically Handicapped*, ANSI A117, New York, 1980.
- COMMONWEALTH OF KENTUCKY, *Investigative Report to the Governor—Beverly Hills Supper Club Fire, May 28, 1977*, Frankfort, Kentucky, September 16, 1977.
- NATIONAL FIRE PROTECTION ASSOCIATION, *Fire Protection Handbook*, 14th Ed., Boston, Mass., 1976.
- National Fire Codes*, published annually, Boston, Mass.
- Life Safety Code (NFPA No. 101)*, Boston, Mass., 1976.
- Reconstruction of a Tragedy—The Beverly Hills Supper Club Fire*, Boston, Massachusetts, 1977.
- NATIONAL BUREAU OF STANDARDS, “Design and Construction of Building Exits,” *NBS Miscellaneous Publication M151*, Washington, D.C., Oct. 10, 1935.
- Fires and Human Behaviour*, David Canter, Editor, John Wiley and Sons, 1980. (Chapter 5, “The Concept of Panic,” Jonathan D. Sime).
- CLEVELY, HUGH, *Famous Fires*, The John Day Company, 1958.

FIRE RESISTANCE AND FIRE SEVERITY

Fire resistance is that property of a material or assembly which enables it to withstand or give protection from fire. In modern building codes this term is more precisely defined, with respect to certain construction assemblies, as the ability to confine a fire to a given area or to continue to perform structurally when exposed to fire, or both. In contrast, fire endurance is the time period during which a material or construction assembly continues to exhibit fire resistance and to perform these functions when exposed to fire. In North America, fire endurance has historically been determined through laboratory tests conducted in accordance with procedures developed by the American Society for Testing and Materials (ASTM). The most widely used of these procedures are described in the "Standard Methods of Fire Tests of Building Construction and Materials," ASTM E 119. This test method is used to evaluate walls, partitions, beams, columns, floor, and roof assemblies. Similar procedures are used for determining the fire endurance of door and window assemblies. In addition to ASTM, other organizations such as the National Fire Protection Association (NFPA) and Underwriters Laboratories Inc. (UL) and the Canadian Standards Association (CSA) also publish fire test methods which are virtually identical to those developed by ASTM and are generally considered to be equivalent. A comprehensive discussion of the current provisions in ASTM E 119 is given in Chapter 7.

Fire test methods were first developed in the early 1900's when the most significant fire protection problem was to devise measures that would prevent the huge losses resulting from conflagrations. During and prior to this period large portions of several cities had been devastated by these sweeping fires. As a result, the early test methods were oriented toward the development of so-called "fireproof" buildings which could resist exposure to the severest fires without structural failure.

Very little information was available relative to the intensity and

duration of actual building fires and the primary purpose of the first formally described test methods was to standardize procedures. More recently, research on the factors which influence the growth, development and severity of building fires has been undertaken and it has become increasingly apparent that standardized fire test methods do not always accurately represent the conditions present in real fires. In addition, experience in applying the results of fire tests to actual building designs has revealed several limitations inherent in the test procedures. For these reasons, recent emphasis has been placed on the development of engineering methods for the design of fire resistant components of buildings.

History of Early Fire Endurance Testing

The first reported fire endurance tests in the United States were conducted in Denver, Colorado in 1890. The purpose of these tests was to determine which of three floor systems, proposed by different contractors bidding on the construction of the Denver Equitable Building, was the most fire resistant. Representative samples of the floor systems were subjected to fire exposures for 24 hours, as well as load and hose stream tests. Throughout the 1890's, similar ad hoc fire endurance tests were conducted in other American cities.

In 1896, the New York City Building Department organized a comprehensive series of comparative structural fire endurance tests. These tests were prompted by the general state of confusion which then existed with respect to "fireproof" floors. Many proprietary floor systems had been developed which were being widely promoted as "fireproof" and because much of the information supporting these claims was questionable, the Superintendent of Buildings for New York City decided to sponsor large-scale fire tests to investigate the relative performance of the more predominant methods of floor construction. The fires were fueled with wood positioned on open grates in brick kilns and, during the last four hours of the 5-hour test, the furnace temperature was maintained as nearly as possible at 2000F (1093C). At the end of each test, the assemblies were subjected to a hose stream application and the fire was extinguished. A uniform load of 150 pounds per square foot (732 kg/m^2) was imposed on the floor assemblies during the fire test. Afterwards, this load was increased to 600 pounds per square foot (2928 kg/m^2) and maintained for 24 hours. As a result of the information collected during these tests, the New York City Building Code was later amended to require the testing of floor

assemblies proposed for use in "fireproof" buildings. The specified test conditions were essentially the same except that the required furnace temperature was reduced to 1700F (927C). In order to be considered acceptable, the floor assembly must not have suffered "appreciable damage nor allowed the passage of fire."

Because these tests were very expensive (in most cases a new furnace had to be constructed for each test) the need for a permanent facility quickly became apparent. In response, the Columbia Fire Testing Station was established in 1902. The station was organized as a private venture by Ira H. Woolson, Adjunct Professor of Civil Engineering at Columbia University. By 1919, when Professor Woolson retired and the testing was discontinued, a total of 47 fire endurance tests had been conducted at the "Columbia Station." The information gathered from these early tests formed the basis for the development of the first standard fire test methods.

The movement toward standardization began in 1903 with the convening of the International Fire Prevention Congress in London. Sponsored by the British Fire Protection Committee, this Congress had a membership of 840 delegates. One of the most significant actions taken was the endorsement of the British Committee's proposed universal standards for fire protection. These standards were intended to classify assemblies which provided "temporary," "partial," or "full" protection against fire. In addition, the Congress condemned the use of the term "fireproof" as applied to buildings and recommended instead, the use of "fire-resistive."

Following the 1904 Baltimore conflagration ASTM organized Committee P (predecessor of the current Committee E-5 on Fire Tests). The Baltimore fire, which burned for 2 days, destroyed an estimated 2500 buildings and resulted in total monetary losses approaching 100 million dollars. The significance of this fire, other than the sheer magnitude of the loss, was the severe test that it provided for a wide variety of buildings considered to be of "fireproof" construction. Although many of the steel framed structures in Baltimore performed quite well considering the severity of the fire, investigations revealed numerous deficiencies in some fire protection methods. These deficiencies demonstrated that large-scale tests were needed to evaluate the performance of construction assemblies under fire conditions. Committee P immediately began the development of a standard fire test for floors and in 1906, a proposed test standard was published. The test method specified a wood fire, producing an average furnace tempera-

ture of 1700F (927C) for all but the first one-half hour of the four hour test. During the fire exposure, the floors were loaded to 150 pounds per square foot (732 kg/m²) and afterwards, to 600 pounds per square foot (2928 kg/m²). A hose stream test was also specified.

Since Professor Woolson was chairman of this committee, it is not too surprising that the proposed standard was very similar to that previously used by the City of New York and the "Columbia Station." As finally adopted in 1908, the standard was revised to allow the use of gas and oil fires as well as wood. The acceptance criteria were that no fire or smoke break through the assembly, that it survive the hose stream application, and the assembly not suffer damage sufficient to make it incapable of sustaining load. The following year a similar standard was developed for partitions, a major difference being the requirement of a two-hour fire exposure instead of four hours. The development of this latter standard coincided with an extensive testing program on partitions sponsored by the United States Geological Survey for the purpose of developing information pertinent to the design of United States government buildings. In all, 30 partitions were tested in a furnace originally constructed at Underwriters Laboratories for testing doors, windows, and shutter assemblies. The test conditions were similar to those specified in the ASTM standard but the results of this project were not widely accepted primarily due to the limited size of the specimens. However, the information contributed significantly to the understanding of the performance of partitions under fire test conditions.

In 1910 the Associated Factory Mutual Fire Insurance Companies and the National Board of Fire Underwriters began preliminary planning for a significant testing program on building columns. In 1914, the National Bureau of Standards agreed to cooperate in the project and construction of the test facility was completed at the Underwriters Laboratories in early 1917. A total of 106 tests were conducted on a wide variety of column assemblies at this facility. Many fire resistant column designs are still based upon the results of this early testing program.

The 1918 Standard Fire Test Method

In 1916, ASTM Committee P was reorganized as Committee C-5 and began the preparation of a new fire test standard which was formally adopted two years later. Provisions for the testing of both floor and wall assemblies were included, thus replacing the separate stand-

ards adopted in 1908 and 1909. Columns were still not covered since the committee was awaiting the completion of the testing program at Underwriters Laboratories.

The new standard included several major changes in the philosophy of fire resistive construction. Undoubtedly, the single most significant change introduced in the standard was the concept of classifying construction by time-related endpoint criteria instead of a simple pass/fail criterion. The earlier standards had required 4-hour exposures for floors and 2-hour exposures for walls for an assembly to qualify as "fireproof". In contrast, the 1918 edition did not specify the duration of the test but, instead, defined end-point conditions which were deemed to be "failure" of the assembly. A time designation was assigned when the end-point criteria are reached and assemblies classified according to fire endurance as $\frac{3}{4}$, 1, 1½, 2, 3, or 4-hour construction. The end-point criteria were defined in terms of the ability to resist the transmission of heat and to sustain applied loads. The temperature rise on the unexposed surface of wall assemblies was initially limited to 300F (167C) but because it was observed that the temperature of brick and hollow tile walls continued to rise after the fire test, the temperature rise was later reduced to 250F (139C).

Another feature of this edition of the standard was the requirement that both floor and wall assemblies be tested for a time 25 percent greater than the desired classification. This margin of safety was deleted from the next edition and has not been re-introduced. In addition, the magnitude of applied loading for floor assemblies was no longer specified. Instead, the test method required that floors be loaded "in a manner to develop in each member of the construction stresses equal to the maximum safe working stress allowed in the material of the member."

The concept of different time-rated constructions considerably broadened the applicability of the fire test results. The first test methods had been primarily developed for a single application, namely "fireproof" construction. Since this type of construction was almost exclusively limited to large commercial buildings, both the duration of exposure and the magnitude of applied loads were specified. "Fireproof" buildings were not, however, the only types of buildings where fire rated construction was needed. Thus, since the 1918 standard recognized that in many circumstances lesser fire endurance classifications were needed and adequate, it broadened the concept of fire-resistant construction to include many buildings and types of construc-

tion that had not been in this category. Another significant change introduced by the 1918 edition was the Standard Time-Temperature Curve illustrated in Figure 2. This curve establishes the average furnace temperature as a function of time for all fire endurance tests. In contrast

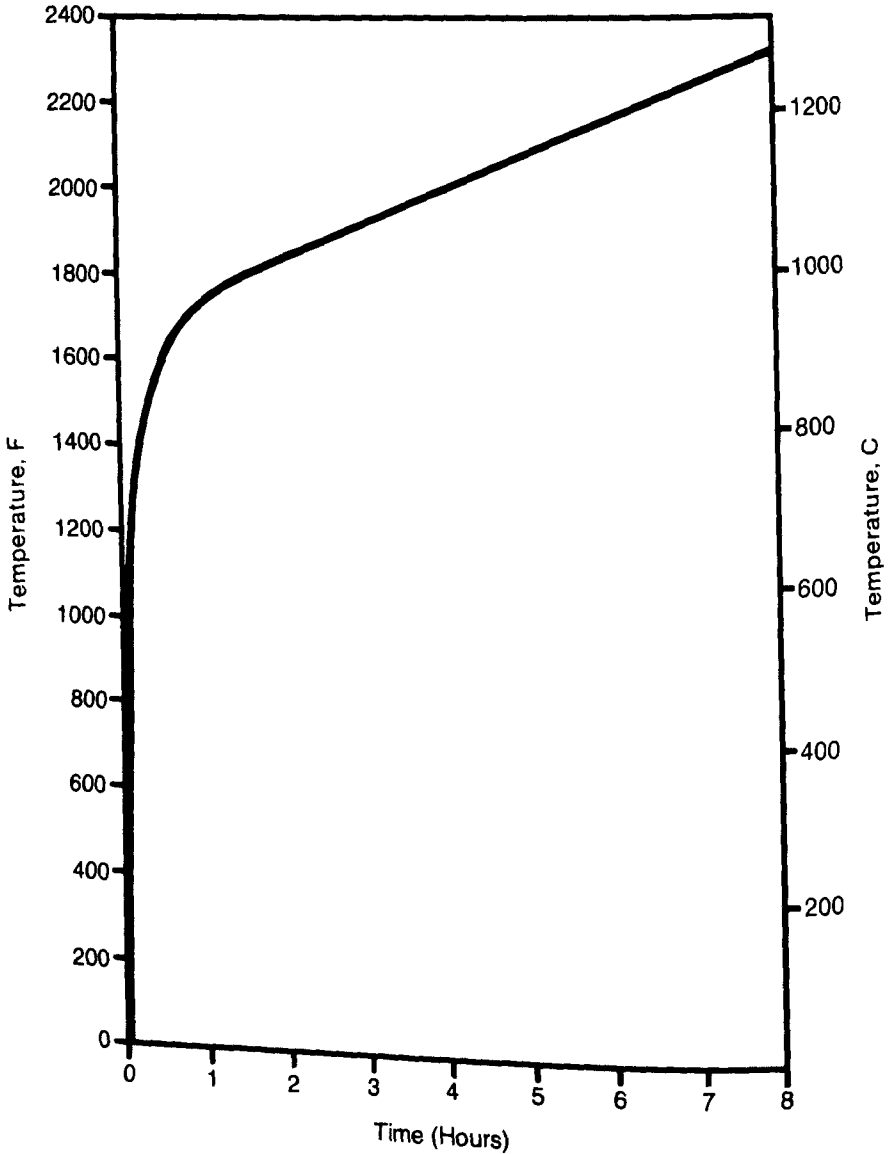

Figure 2. Time-temperature curve from "Standard Methods of Fire Tests of Building Construction and Materials" (ASTM E119-80).

to the constant 1700F (927C) exposure previously specified, the curve rises rapidly to 1550F (843C) at 30 minutes and then increases more gradually to 2000F (1093C) at 4 hours. The proceedings of the conferences which developed the Standard Time-Temperature Curve were not published and much of the historical basis for this curve has never been completely documented. Nevertheless, it is known that the committee was primarily interested in developing an exposure which would be reproducible in existing laboratory facilities. Many years of experience had shown that it was frequently very difficult, even with gas-fired furnaces, to achieve and maintain a steady temperature as had been a requirement, and that a gradually rising time-temperature curve could be more consistently duplicated. The Standard Time-Temperature Curve represented the committee's best judgment as to what constituted a realistically severe fire exposure. As illustrated in Figure 3, similar curves are defined in fire test methods used in many other countries.

Many revisions to the standard fire test method have been adopted in recognition of new construction techniques and fire protection materials, but the Standard Time-Temperature Curve and the concept of time-rated construction have remained essentially the same as when first introduced in 1918.

Development of the Fire Load Concept

A new concept of fire resistant construction was brought about by the adoption of the 1918 "Standard Specification for Fire Tests of Materials and Construction," ASTM C19. While desirable, it presented the fire protection and code enforcement communities with a major technical obstacle to the rational application of fire test results. Simply stated, there was no accepted method for establishing the appropriate levels of fire endurance necessary for the structural components of buildings of different sizes and occupancies. Although it was recognized that typical fires in mercantile and industrial occupancies differed significantly from residential fires, it was not understood how their severity related to the conditions in the standard fire test. In an attempt to bridge this gap, the National Bureau of Standards in 1922 undertook an ambitious program to investigate the nature of building fires. This program was under the direction of Simon H. Ingberg. The primary objective of this effort was to determine the intensity and duration of uncontrolled fires in certain occupancies resulting from different levels of fire load. A second objective was to investigate the validity of the Standard Time-Temperature Curve.

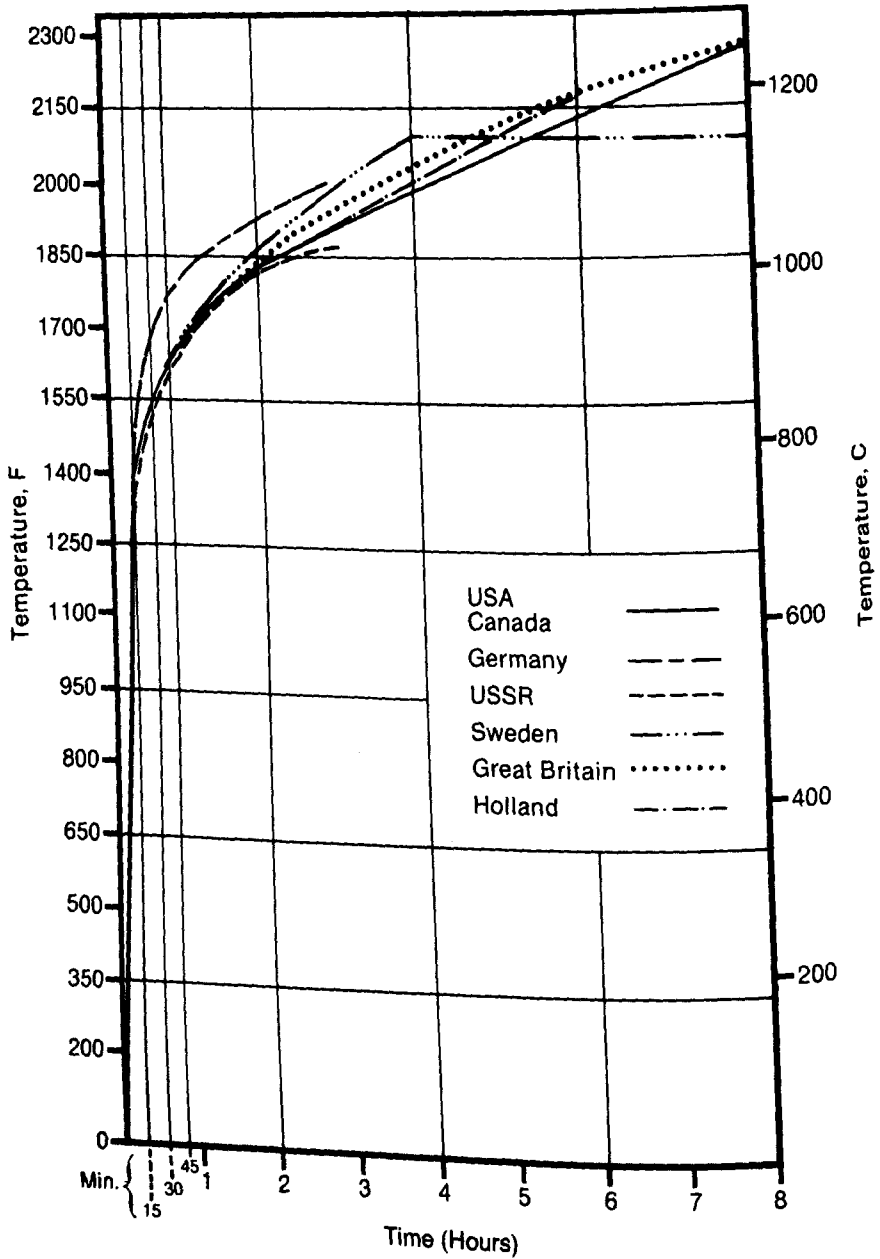

Figure 3. A comparison between time-temperature curves used in structural fire testing in various countries.

Special one-story fire-resistive buildings were constructed for these tests. The first building was approximately 15 feet by 30 feet (4.6 m by 9.1 m) in plan with a 9-foot (2.7 m) ceiling height. So that the significance of building size could be investigated, a second building 30 feet by 60 feet (9.1 m by 18.3 m) in plan was constructed. Ten complete burnout experiments were conducted. In six, the buildings were furnished with desks, file cabinets, and other contents considered to be typical of office and light commercial occupancies. The other four tests were intended to simulate fires in record storage areas involving high concentrations of combustible contents. The total weight of combustible contents was determined prior to each test. The fires were started using wastepaper baskets or oil-soaked wood cribs, the latter designed to simulate an intense ignition source. Adjustable shutters, located in the exterior walls, were “regulated to give what was deemed to be the proper amount of air for maximum fire conditions.” Temperatures at various locations throughout the buildings were recorded at frequent intervals during the fires. A curve of the average temperatures recorded during one of the tests of a record storage area is illustrated in Figure 4. For comparative purposes, the Standard Time-Temperature Curve is also shown.

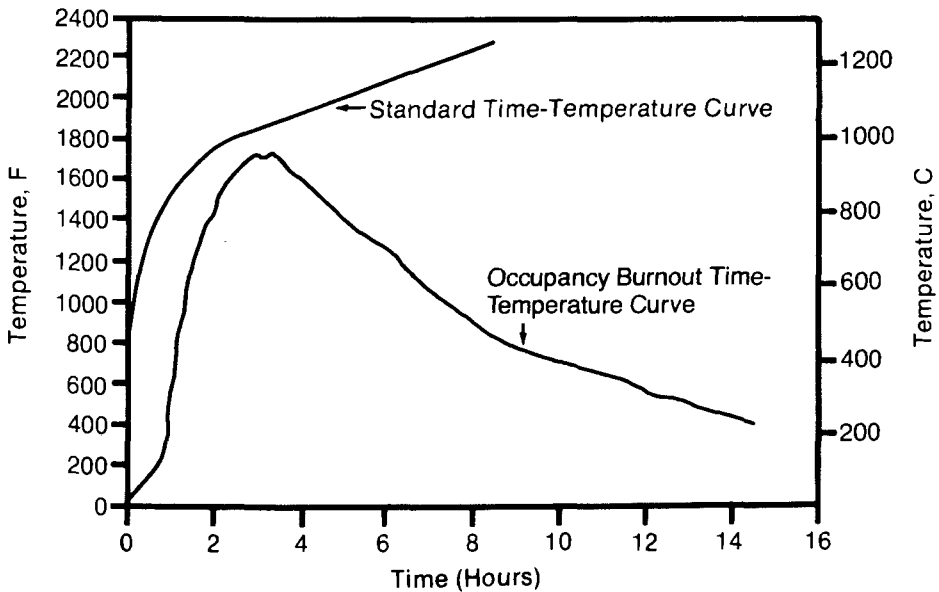

Figure 4. Average time-temperature curve reported by Ingberg for a record storage area.

In addition to the influence of building size and fire load, the effects of combustible and noncombustible flooring, and wood and steel furniture were also investigated. On the basis of the data collected from these experiments, it was suggested that a simple relationship could be established between the average weight of combustible material within a room and the fire endurance necessary to withstand a complete burnout of the contents. This relationship, generally referred to as the "fire load concept" is shown in Table 2. As defined, fire load is expressed in terms of pounds of combustible material per square foot of floor area (psf). In all cases, the fire load is determined on the basis of wood and similar cellulosic materials which have a potential heat of approximately 8000 Btu's per pound (18,608 kJ/kg). For materials with significantly different potential heats, the fire load is computed on a wood equivalent basis.

Table 2—Relationship Between Fire Load and Fire Endurance

Average Fire Load psf*	kg/m ²	Equivalent Fire Endurance (hours)
5	24.4	½
7½	36.6	¾
10	48.8	1
15	73.2	1½
20	97.6	2
30	146.5	3
40	195.3	4½
50	244.1	6
60	292.9	7½

*Determined on the basis of a potential heat of approximately 8000 Btu's per pound.

The "fire load concept" was developed from two assumptions: 1) that the area under any time-temperature curve from ignition through the cool down or decay phase provides a comparative measure of fire severity; and 2) that the "fire severity" so defined is uniquely a function of the fire load. According to the first of these assumptions, a short but intense fire is equivalent to a longer more moderate fire so long as the areas under the respective time-temperature curves are the same. This concept is illustrated in Figure 5. On the basis of this assumption, Ingberg was able to compare the time-temperature curves generated in the burnout tests to the Standard Time-Temperature Curve. So that this

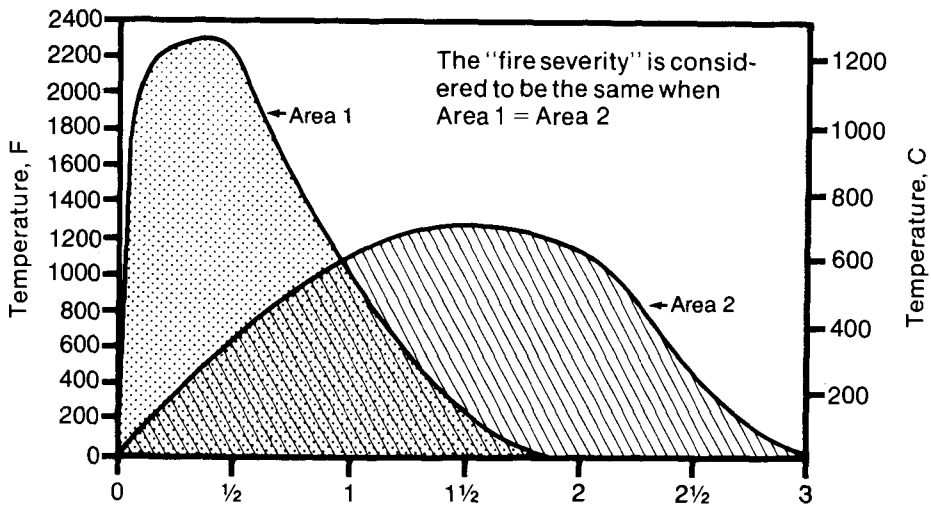

Figure 5. The "fire severity" concept.

comparison could be made on an equivalent basis, standard fire endurance tests were also conducted except that the furnace temperatures were recorded during the cool-down period after the fire was extinguished. These curves are illustrated in Figure 6. Since the primary variable in the burnout experiments was the fire load, the greater the fire load the greater the area under the corresponding time-temperature curve. By comparing these areas to the areas under the Standard Time-Temperature Curve, including the cool-down period, Ingberg developed the relationship between fire load and requisite fire endurance as given in Table 2. In comparing the time-temperature curves, only the areas above approximately 300F (149C) were considered significant.

Ingberg concluded that a building of 1-hour fire-resistant construction should be capable of surviving the complete burnout of a fire load of 10 psf (49 kg/m²) without collapse of a major component. He further pointed out that these results apply primarily to buildings of noncombustible construction.

"The severity of fires completely consuming the combustibles of frame buildings and masonry-walled buildings with combustible interior construction is of interest mainly as it concerns the exposure to adjacent or neighboring buildings and the fire exposure on party and fire walls and on record containers. As it concerns the severity of fires in buildings with interior combustible construction protected with incombustible floor, ceiling and wall finishes, the present discussion will apply up to the limit set by the fire resistance of such protection." NFPA Quarterly, Volume 42, No. 1, July 1928

Thus, for buildings of combustible construction, it is also necessary to take into consideration the contribution of the building construction to the total fire load and the degree of protection, if any, provided for the combustible construction elements.

In order to apply this concept to real buildings, it was necessary to determine the typical "fire load" for different occupancies. Surveys for this purpose were undertaken and their results are summarized in Chapter 4. Although the "fire load concept" has not been incorporated into modern building codes directly, it has been widely accepted as the general basis for establishing fire endurance requirements.

Contemporary Fire Research

In the years since Ingberg's pioneering work, much research has been devoted to further defining and understanding the nature of building fires. Further research has advanced fire protection engineering to the point where it is now possible to significantly refine the fire load concept. The assumption that fire severity can be quantified as equivalent to the area under a time-temperature curve does not consider the effects of temperature on common building materials. For example, the

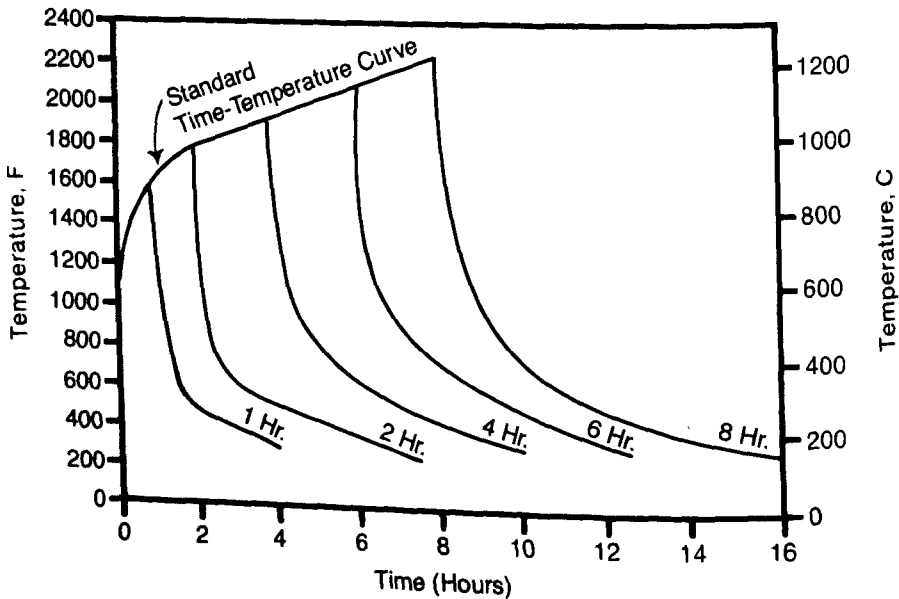

Figure 6. Furnace cool down curves reported by Ingberg for various standard fire endurance times.

maximum temperature attained is much more significant in its effect on structural steel than the duration of fire.

Recently, the International Standards Organization Technical Committee on Fire Tests of Building Materials and Structures described a modification of the definition of fire severity which is graphically illustrated in Figure 7. As can be seen, the cool-down or decay phase associated with the Standard Time-Temperature Curve is not included in the area determination. This modification is justified since the performance of construction assemblies is not evaluated during the cool-down phase of a standard fire endurance test. In addition, only the areas above a specified temperature need be considered where the critical temperature is defined in terms of the characteristics of specific construction materials such as structural steel. According to the current provisions in ASTM E 119, an appropriate critical temperature for structural steel columns loaded to their design capacity is 1000F

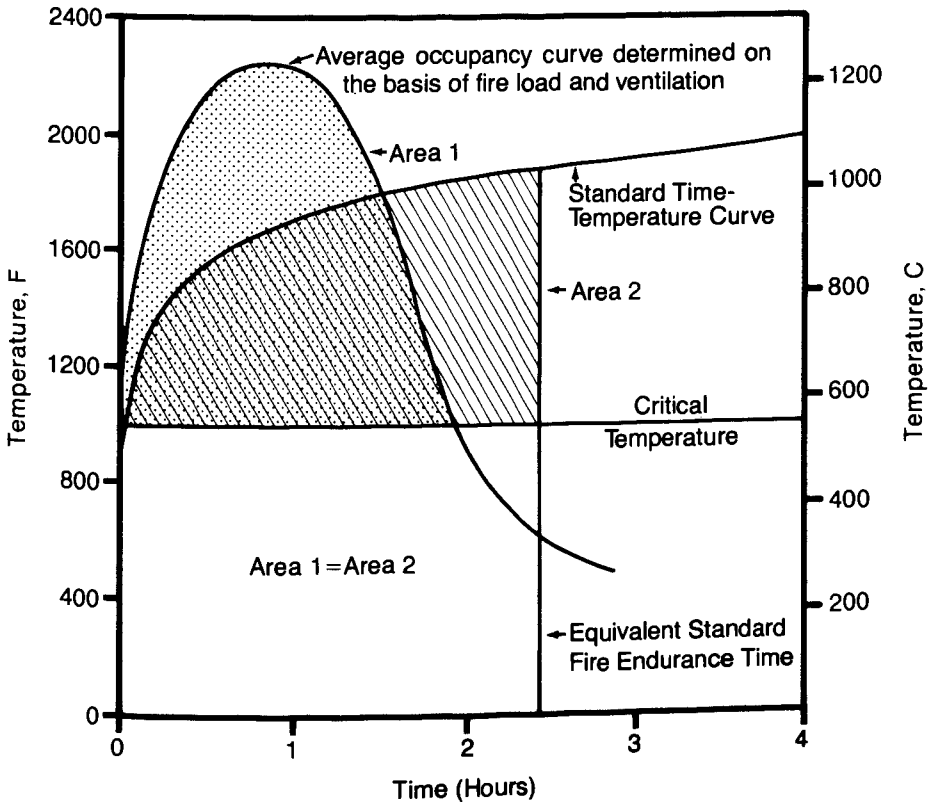

Figure 7. Determination of equivalent fire endurance time. ISO Technical Report 3956

(538C). The critical temperature limits for beams and girders is somewhat higher. Thus, the significance of fire severity depends not only on the time-temperature curve but also on the building design. In general, unprotected structural steel members will perform adequately in fires which result in maximum steel temperatures of less than 1000F (538C) either due to the fire severity or the location of the steel with respect to the burning material.

The time-temperature curve generated during an actual fire is a function not only of the fire load but also four other factors:

1) ventilation (air access through windows and doors); 2) compartment geometry (floor area and ceiling height); 3) thermal properties of the walls, floor, and ceiling construction; and 4) combustion characteristics of the fuel (rate of heat release).

The importance of ventilation was first quantified in the late 1950's although Ingberg recognized its importance in his experimental work and attempted to provide "the proper amount of air for maximum fire conditions." Japanese researchers discovered that the rate of burning within a compartment is frequently controlled by ventilation and can be largely independent of the fire load. On the basis of numerous experiments, an empirical relationship was developed between the rate of burning and the height and area of openings in compartment enclosures. Research sponsored by American Iron and Steel Institute at the Underwriters Laboratories in 1967 further substantiated the importance of ventilation rates. A series of tests were performed to determine the severity of fire exposure resulting from building fires on exterior steel members. Time-temperature curves were recorded during room burn-out tests involving various combinations of fire load and ventilation. Some of these curves are given in Figures 8 and 9. The effect of ventilation is clearly illustrated in Figure 8, which shows four average time-temperature curves for a fire load of 10 psf (49 kg/m²) and different size windows. As can be seen, increasing the window area results in higher peak temperatures and a more rapid decay phase. In addition, the smallest window produced a time-temperature curve which most closely resembled the Standard Time-Temperature Curve. Similarly, Figure 9 contains three average time-temperature curves for fire loads of 10, 15, and 20 psf with a forced air flow of 4800 cubic feet per minute (2.27 m³/s). Under these conditions, with ample air supply, fire load had little effect.

It is now recognized that two entirely different types of fires can occur within buildings or compartments. The first is a "fuel surface

controlled fire” which will develop when the compartment openings are sufficiently large to provide adequate combustion air for unrestricted burning. Such fires will generally be of short duration and the intensity will be controlled by the fire load and its arrangement. The second type of fire is “ventilation controlled” and will develop when the compartment openings are not large enough to allow unrestricted burning.

The National Research Council of Canada has evaluated the fire load concept in terms of the influence of ventilation, and characteristic time-temperature curves have been developed as a function of both fire

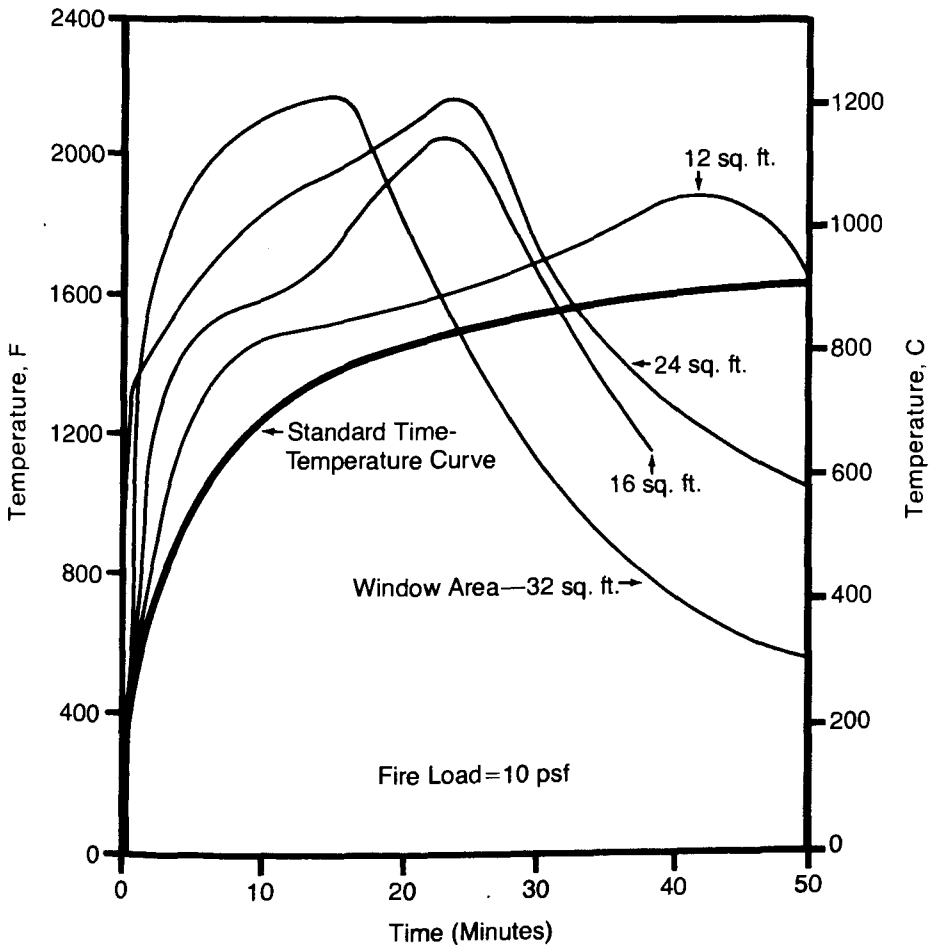

Figure 8. Effect of window area on fire temperatures during burnout tests with natural ventilation.

load and ventilation. A number of these curves are illustrated in Figures 10 and 11. In addition, Ingberg's relationship between fire load and fire endurance has been theoretically verified for one condition of ventilation.

Design of Fire Resistant Buildings

In North America, building code requirements for fire resistant design are currently based, almost exclusively, on the presumed duration of a standard fire as a direct function of fire load, building occupancy, height, and area. The severity of actual fires is determined

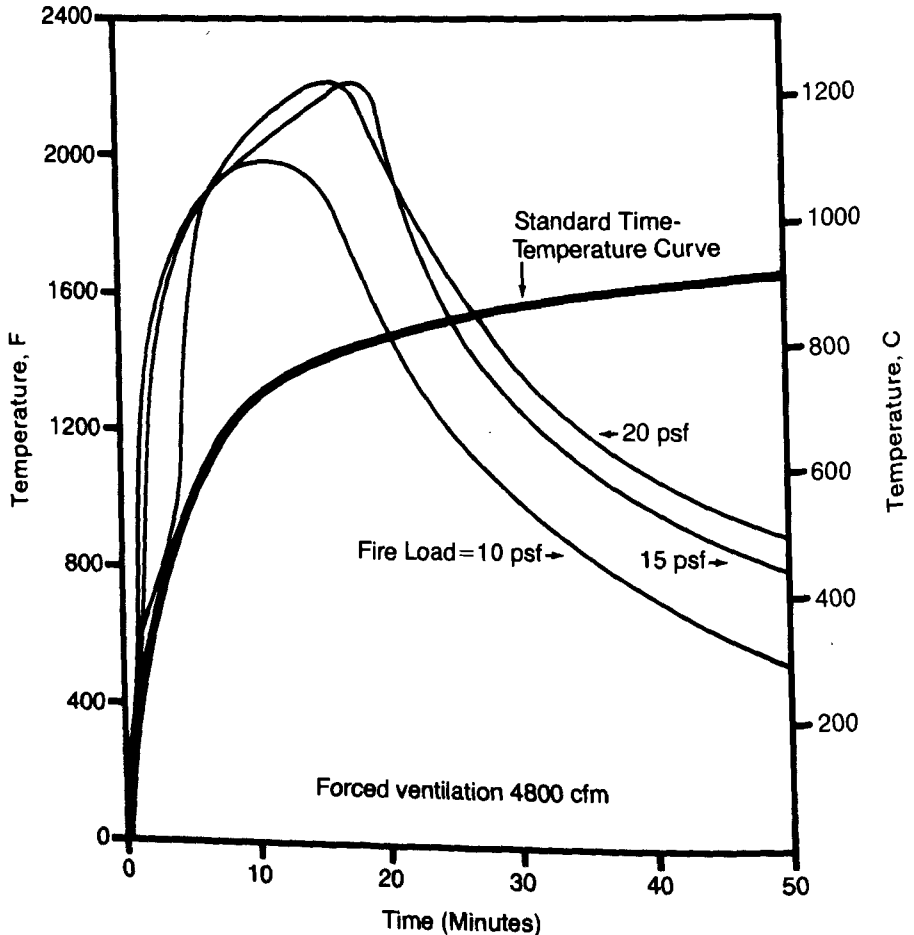

Figure 9. Effect of fire load on temperature recorded during burnout tests with forced ventilation.

by additional factors, which are not considered in present building code provisions. Recent fire research provides a basis for designing fire protection for structural members by analytical methods. These methods involve the solution of heat balance equations for individual compartments and, in conjunction with heat transfer theory, can be used to design the fire protection necessary for various construction assemblies. While many of these methods require the use of computers, simplified design techniques for many typical conditions have been and are being developed. The Swedish Building Authority has accepted one such approach which is described in the *Manual for Fire Engineering Design of Steel Structures*. This manual was developed jointly by the Lund Institute of Technology and the Swedish Institute of Steel Construction.

In addition to providing a realistic framework for the design of

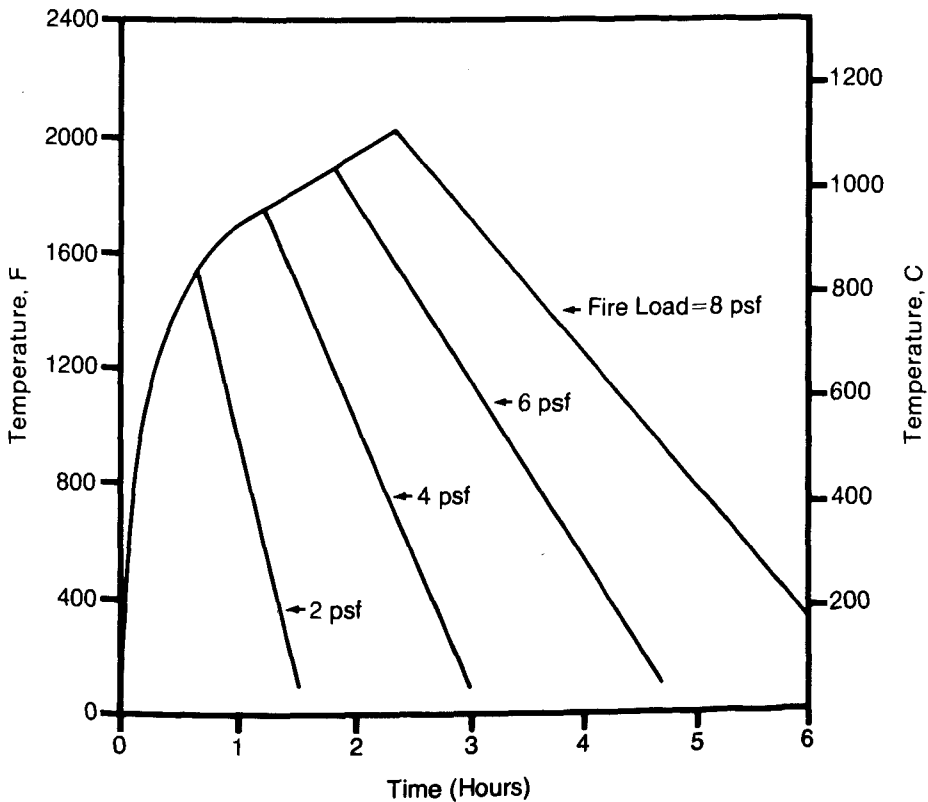

Figure 10. Characteristic time-temperature curves for various fire loads and an intermediate opening factor, as developed by Lie and Stanzak, AISC Engineering Journal, Vol. 13, No. 2, 1976.

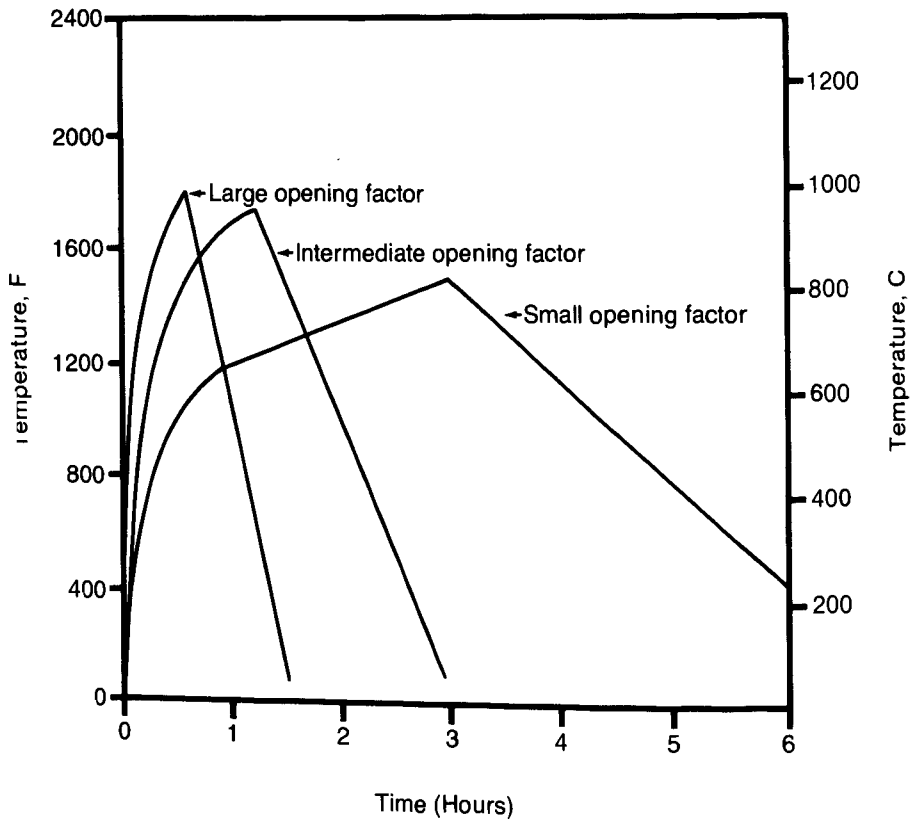

Figure 11. Characteristic time-temperature curves for various opening factors and a fire load of 4.1 psf, as developed by Lie and Stanzak, AISC Engineering Journal, Vol. 13, No. 2, 1976.

specific buildings, these methods also provide architects, engineers and building officials with a technical basis for evaluating conditions which are not included in the scope of the standard fire test. For example, it has long been recognized that the fire exposure described in ASTM E 119 does not simulate the conditions represented by the exposure of exterior structural members to flames emerging from windows or other openings in an exterior wall, or from an adjacent building. Hence, the results obtained by this test method are not applicable to columns and other structural members located outside of the exterior walls of a building. The commentary to the International Standard, Fire Resistance Tests of Elements of Building Construction, ISO 834-1975, emphasizes this point as follows:

“This international standard is limited in application to an experimental determination of the fire resistance of those elements of building construction which either are located in a fire compartment or constitute parts of the structures enclosing a fire compartment. In the latter case, only structural elements exposed to a fire on their internal face are included in the field of application.”

The commentary goes on to illustrate typical exposure conditions for four types of external assemblies as shown in Figure 12. A structural element at location A may be directly exposed on both the internal and external surfaces with different heating conditions. An element at location B may be directly exposed to fire on its internal surface and simultaneously to radiation from flames emerging from the fire compartment. In those cases where the effect of radiation is unimportant, such an element can be evaluated in accordance with the standard fire test procedure. The fire exposure for an element at location D is on the external surface only and is not represented by the Standard Time-Temperature Curve. For Type D elements, such as an external column,

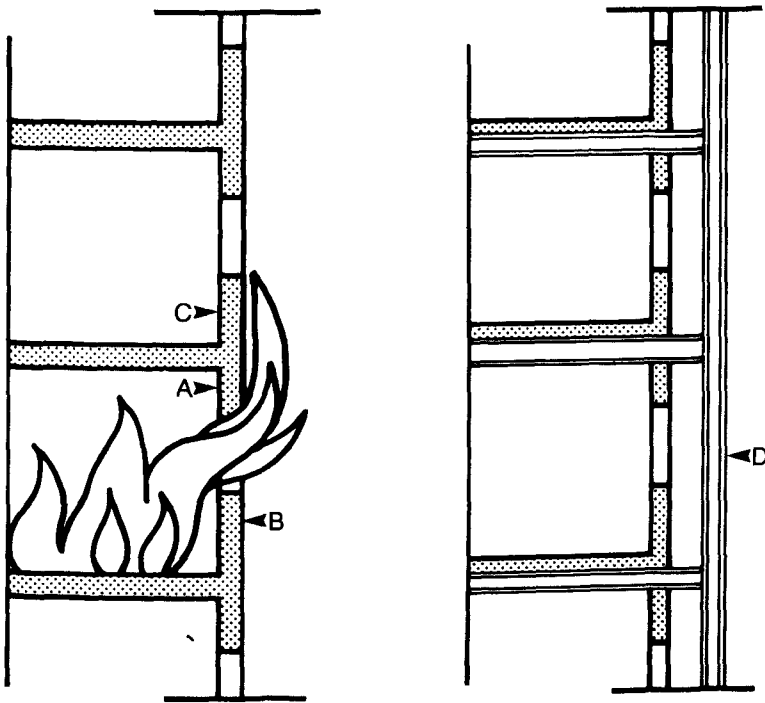

Figure 12. Typical fire exposure conditions for exterior elements. ISO International Standard 834.

compartment fires result in exposures which vary along the length of the column and are largely determined by the location of the column with respect to openings in the exterior walls.

Even though these elements are exposed to conditions significantly different than the Standard Time-Temperature Curve, the absence of alternative procedures for evaluating their performance has forced building designers and code officials to utilize assemblies tested according to the standard fire test method for these applications. In an effort to provide such an alternative, American Iron and Steel Institute has recently sponsored the development of the *Design Guide for Fire Safety of Bare Exterior Structural Steel*. This Design Guide includes a procedure which can be used to evaluate the fire safety of a design incorporating unprotected exterior structural steel elements using well established heat transfer and heat balance principles. As applied to members on or close to a building exterior, these principles give totally different results than are obtained during a fire exposing an internal building element.

Fire Test Standards and Model Building Codes

Fire resistance ratings were not used in conjunction with the building classifications in early editions of building codes. It was not until the first edition of the Uniform Building Code, published in 1927, that fire resistance ratings were recognized as a means of evaluating assemblies and establishing types of construction. Today, all of the model building codes and the codes of major cities reference the standard fire endurance test procedure as described in ASTM E 119 for determining the acceptable performance of structural components.

Although the "fire load" concept has been widely recognized for many years, it has not been directly utilized in the development of fire resistance requirements in modern building codes, with the possible exception of the New York City Building Code. However, virtually all contemporary building codes contain some fire resistance requirements as a function of building occupancy. While fire load is clearly related to building occupancy, its relationship to fire resistance requirements is obscured by other considerations. A more thorough discussion of these requirements is contained in Chapters 4, 6 and 10.

Summary

Fire resistance requirements, as specified in modern building codes, are based upon test methods first developed in the early 1900's. The

primary objective of these methods is to determine the length of time that a construction assembly will contain a standard laboratory fire or, in the case of load bearing members, the length of time that they will support design loads. Thus, fire endurance, expressed in terms of hours has been established as a significant performance requirement.

At the time when these test methods were originally developed very little information was available concerning the nature of real building fires and the development of these test procedures was largely based upon the experience and judgment of the individuals who pioneered this work. In the years since, much research has been devoted to analyzing the behavior of building fires. This research has led to a better understanding of the significance and limitations of the standard fire endurance tests.

In addition, analytical procedures have been developed for more accurately determining the fire resistance of construction assemblies. Even though these procedures are not yet directly recognized by all building codes, provisions are now being included in codes which allow for their consideration by the design professionals and building officials.

References

AMERICAN IRON AND STEEL INSTITUTE, *Design Guide for Fire Safety of Bare Exterior Structural Steel*, Ove Arup and Partners, London, England, 1977.

AMERICAN SOCIETY FOR TESTING AND MATERIALS, *Report of Committee C5 on Fireproofing*, *ASTM Proceedings* Vol: 17, Part 1, pps. 295-300, Philadelphia, PA, 1917.

AMERICAN SOCIETY FOR TESTING AND MATERIALS, *Standard Specification for Fire Tests of Materials and Construction*, *ASTM Designation C19-18*, Philadelphia, PA 1918.

AMERICAN SOCIETY FOR TESTING AND MATERIALS, *Standard Tests for Fireproof Floor Construction*, *ASTM C2-08*, Philadelphia, PA 1908.

AMERICAN SOCIETY FOR TESTING AND MATERIALS, *Standard Tests for Fireproof Partition Construction*, *ASTM Standard C3-09*, 1909.

AMERICAN SOCIETY FOR TESTING AND MATERIALS, *Standard Methods of Fire Tests of Building Construction and Materials*, ASTM E-119-1979, Philadelphia, PA, 1979, (NFPA Standard No. 251, UL Standard No. 263, and ANSI Standard No. 2A.1).

BRITISH FIRE PREVENTION COMMITTEE, *The Official Report of the First International Fire Prevention Congress*, London, 1903.

FUJITA, K., "Characteristics of Fire Inside a Non-Combustible Room and Prevention of Fire Damage," Japanese Ministry of Construction, Building Research Institute, *Report Two (2)*, Tokyo.

HARMATHY, T.Z. AND LIE, T.T., "Fire Test Standard in Light of Fire Research," American Society for Testing and Materials, *Special Technical Publication 464*, 1970.

HIMMELWRIGHT, A.L.A., *The Baltimore Conflagration and Iroquois Theater Fire*, The Roebling Construction Company, New York, 1905.

INGBERG, S.H., "Tests of the Severity of Building Fires," *Quarterly*, National Fire Protection Association, Vol: 42, 1928.

INGBERG, S.H., GRIFFIN, H.K., ROBINSON, W.C., AND WILSON, R.E., "Fire Tests of Building Columns," National Bureau of Standards *Technologic Paper No. 184*, Washington, D.C. 1912.

INTERNATIONAL STANDARDS ORGANIZATION, "Fire Resistance Tests—Elements of Building Construction," *ISO/R 834-1975*.

INTERNATIONAL STANDARDS ORGANIZATION, "Principles of Structural Fire Engineering Design With Special Regard to the Connection Between Real Fire Exposure and the Heating Conditions of the Standard Fire Resistance Tests," *Technical Report 3956*, Technical Committee 92, Switzerland, 1975.

KAWAGOE, K., "Fire Behavior in Rooms," Japanese Ministry of Construction, Building Research Institute, *Report Twenty-Seven*, Tokyo, 1958.

LIE, T.T., "Characteristic Temperature Curves for Various Fire Severities," *Fire Technology*, Vol: 10, No. 4, 1974.

LIE, T.T., *Fire Resistance of Structural Steel*, National Research Council of Canada, Division of Building Research, Ottawa, 1978.

LIE, T.T. AND STANZAK, W.W., "Structural Steel and Fire—More Realistic Analysis," *Engineering Journal*, American Institute of Steel Construction, Vol: 13, No. 2, 1976.

"Steel Structures in the Baltimore Fire," *The Iron Age*, February 25, 1904.

THOMAS, P.H., HESELDEN, A.J.M., AND LAW, M., "Fully Developed Compartment Fires—Two Kinds of Behavior," Joint Fire Research Organization, *Fire Research Technical Paper No. 18*, London, 1967.

THOR, J., PETTERSSON, O., AND MAGNUSSON, S.E., "A Rational Approach to Fire Engineering Design of Steel Buildings," *Engineering Journal*, American Institute of Steel Construction, Vol: 14, No. 3, 1977.

UNITED STATES GEOLOGICAL SURVEY, *Bulletin No. 324*, "The San Francisco Earthquake and Fire," Washington, D.C. 1906.

UNITED STATES GEOLOGICAL SURVEY, *Bulletin 370*, "The Fire Resistive Properties of Various Building Materials," Washington, D.C. 1909.

WHARTON, C., "Standard Fire Tests," Building Officials Conference, *Proceedings of the Fourteenth Annual Meeting*, Chicago, IL 1927.

OCCUPANCY CLASSIFICATION AND HAZARDS

Many building uses have similar fire hazard characteristics and similar life-safety problems. The designation of these uses into one of several occupancy groups is common to modern building codes. The purpose of occupancy classifications is to simplify the application of code regulations governing construction, fire protection and other life safety requirements. By grouping similar uses into a single occupancy classification or subclassification the code can be more consistent and easier to use. However, every classification must be based on the premise that the uses included will all have similar fire and life hazard characteristics and no wide difference in hazard will exist within any occupancy group.

Determination of Occupancy Classifications

Occupancies having similar life-safety characteristics, combustible content, and fire hazards should be classified under the same occupancy heading in building codes. If occupancies of widely different fire hazards were grouped together, the regulations providing for fire protection of the more hazardous group would impose a penalty on the construction of buildings housing the lesser hazard, thus needlessly increasing building costs. For each occupancy group and subgroup a different set of fire-protection requirements, height and area limitations, and exit facilities are usually needed in order to achieve equivalent safety in building design.

For many years, code authorities advised against introducing exceptions into the code that provide for uses not fitting any of the established occupancy groups. However, as more and more buildings are designed either for a specialized purpose or as a part of a larger building complex, the need for special code considerations has been accepted. Some examples of special uses include automobile parking structures, enclosed stadiums, power generating plants, enclosed shopping malls,

atriums, airport terminals, and large industrial facilities such as steel mills and assembly plants.

High-hazard occupancies, which include certain types of chemical processing plants, factories processing dangerous metals (i.e., magnesium, titanium), explosives manufacturing plants, and grain elevators, require special building code requirements and industrial safety standards regulating the specific process or hazard.

After an analysis of model code occupancy classifications the Model Code Standardization Council proposed that nine occupancy groups be recognized in building codes, Table 3.

Table 3—Classification of Building Occupancies

- A—ASSEMBLY
- B—BUSINESS
- E—EDUCATIONAL
- F—FACTORY-INDUSTRIAL
- H—HAZARDOUS
- I—INSTITUTIONAL
- M—MERCANTILE
- R—RESIDENTIAL
- S—STORAGE

With a few exceptions all of the model building codes have used these major classifications to identify occupancy groups.

In addition, the major classifications of assembly, factory-industrial, institutional, residential and storage occupancies are further divided into subgroups to accommodate variations in the hazards associated with uses within each group. For example, the residential classification is subdivided into hotel, multiple dwellings and one- and two-family dwellings. Because the fire-load characteristics in factory-industrial and storage occupancies vary considerably depending upon the product or process involved, these occupancies are classified into subgroups of low and moderate hazard.

Mixed Occupancies

Building codes have special requirements for buildings that house more than one occupancy group. The regulations applicable to mixed occupancies govern the respective portions of the buildings, but where

the requirements conflict, those that provide greater safety should prevail.

In buildings containing mixed occupancies, the fire-resistive requirements for separations should be correlated with the fire load or potential fire severity of the occupancies involved and the higher requirement should govern. By varying the requirements with the fire-load characteristics of the occupancies, lesser fire-resistance requirements for occupancy separations may be permitted where low fire loading exists, instead of specifying a single requirement for all separations. Unfortunately, this concept has not been adequately addressed in all model codes and some problems in code interpretation exist.

Where different occupancies are separated by area separation walls or fire walls, each portion of the building may be considered as a separate building in establishing allowable heights and areas. Without this degree of fire separation, a building of mixed occupancy is limited by the most restrictive height and area requirements specified for any of the occupancies in the building. An exception may be made where an occupancy of higher hazard is ancillary to the main use of the building and occupies a minor portion or a limited area of the building. Usually, codes provide that where an accessory use in the building does not occupy more than 10 percent of the net floor area then the occupancy may be considered as ancillary and the occupancy requirements for the building are not governed by the requirements for the accessory use. However, the higher hazard use must be separated from the main use by the fire-resistive construction specified for that occupancy.

Occupancy Change

When a building undergoes a use change that would appreciably increase the fire or life hazard, the building should be required to conform to the more restrictive provisions of the new occupancy group or subgroup. When a use change is proposed, the building department should, under normal administrative procedures, review the proposal and require the necessary safeguards before an approval for the change is granted.

The code should clearly state that a change in building use resulting in a higher fire hazard classification requires compliance with the requirements for the new classification.

Special requirements relative to occupancy changes are found in the administrative portions of building codes, and also in the general occupancy regulations.

Potential Fire Severity and Hazards of Occupancies

As discussed in Chapter 3, building code and fire authorities recognize that there is a relationship between the weight of combustible contents (fire load) and the potential fire severity in a building. When a fire gets out of control and spreads in a building, every pound of fuel in the building including the materials used in the construction of the building, add to the potential fire severity. Therefore, it is important to know the amount of fuel that is likely to be present in the different occupancies and in the various types of building construction in order to evaluate the total fire potential. The nature of the combustible contents of occupancies is also important in evaluating potential hazards from rapid flame spread, smoke and toxic gases.

Data has been developed in surveys of buildings conducted by various municipal and government agencies, including the National Bureau of Standards (NBS). They are summarized in this chapter for the purpose of evaluating the fire potential that may exist in the various occupancies. Although the data for some occupancies were obtained a number of years ago, they are presented here because they still appear to have substantial validity.

Results of the surveys conducted for assembly, business, educational, institutional, residential, and storage occupancies were reported in the National Bureau of Standards report, "Fire-Resistance Classifications of Building Construction", BMS 92, 1942, and for mercantile, factory-industrial and storage occupancies in the NBS report "Combustible Contents of Buildings", BMS 149, 1957. In the NBS report, "Survey Results for Fire Loads and Live Loads in Office Buildings", BSS 85, 1976, new data from a survey of 23 office buildings located in various regions throughout the United States are reported. In addition to presenting fire load data, this recent survey also analyzes the influence of certain building and occupancy characteristics on the size of fire loads.

Factors such as building height, age, and location were not found to have a significant influence on fire load magnitude. Nor does there seem to be any significant difference in fire loads in private and government buildings. The particular use of individual rooms and the duration of such use did affect fire load magnitude and there appears to be a need for additional study of these factors.

In the NBS surveys, sufficient measurements were taken so that the total weight of combustibles within the areas surveyed could be determined. Allowance was made for combustible finishes such as wood

trim, frames, windows, shelves, etc., generally by including one-half of their respective weights. Weights of wood floors also were included in the survey data. The weight of framing members or structural parts of the building were not included. Consequently, to arrive at a building's total fire load, the weight of the combustibles that are part of the structure should be added to the weight of the combustibles associated with the occupancy. The total weight of combustibles in any area is usually prorated over the entire floor area and indicated in pounds per square foot (psf).

Occupancy Classifications

The Board for the Coordination of the Model Codes (BCMC) has recently completed a study of occupancy classifications. As a result, definitions for the nine occupancy groups were developed and specific types of uses were identified for each category. A list containing this information is included in Appendix A. The considerations used to develop these occupancy groups are discussed here.

Assembly Occupancies

The assembly occupancy as defined by building codes usually includes buildings and structures such as auditoriums, theaters, ballrooms, meeting halls, churches, sports arenas and gymnasiums, restaurants and cocktail lounges, exhibition halls and passenger terminals. The life safety hazard common to assembly occupancies is the high density occupant load.

The proposed BCMC classifications include five subgroups which have been classified according to particular characteristics associated with the assembly use. For example, theaters with fixed seats are classified A1, restaurants and nightclubs are classified A3.

In earlier proposals considered by the BCMC group, the assembly occupancy groupings were established on the basis of the occupant load. For example, an A1 assembly occupancy was one with an occupant load of 1000 or more, A2 one with an occupant load of 300 or more but less than 1000, and A3 one of 50 or more but less than 300. There is very little justification in using the occupant load as the sole basis for establishing these occupancy classifications. Even though occupant load is important, the fire hazard characteristics of the use groups as well as potential fire loads must also be related. The hazard to the occupants would be just as great in a darkened theater filled to capacity, regardless of whether it was designed to hold 40 or 300 occupants.

Requirements for additional exits, based upon floor area, to accommodate the higher occupant loads should be covered by the exit provisions of the code.

Combustible Contents—Assembly occupancies are generally considered to have a low fire-load classification. Although assembly buildings are designed for relatively high live loads, such designs are based on the need to provide for the live loads resulting from the concentration of people. These loads have very little significance insofar as indicating the probable combustible content.

Fire load data for assembly occupancies are somewhat limited. That which is available is reported in the NBS report BMS 92 and summarized in Table 4.

Table 4—Fire Loads in Assembly Occupancies

Occupancy	Average Combustible Contents (psf)		
	Movable Property	Exposed Woodwork and Floors	Total
Auditoriums	1.0	4.6	5.6
Gymnasiums	0.3	7.1	7.4
School Lunchrooms	2.6	4.1	6.7

It would seem reasonable to conclude that auditoriums, theaters, churches, gymnasiums, and similar occupancies considered to be within the assembly classification have a fire load (as represented by the combustible contents) much less than 10 pounds per square foot (psf) (49 kg/m²) of floor area. However, certain important exceptions need to be considered.

Libraries represent an occupancy whose classification is somewhat difficult to determine. Reading areas can be considered as having little hazard and should be treated as an assembly occupancy. Areas where books are stacked in open racks several tiers high should be considered medium-hazard storage occupancies for the purpose of establishing fire protection requirements. The recent NBS survey of office buildings (BSS 85) found libraries to have a total fire load range from 23 to 30 pounds per square foot (112 to 146 kg/m²).

Another occupancy that may have a higher fire load than most assembly uses is the exhibition hall. An exhibition hall will, at times, not only house large numbers of people but may also contain fire loads

even greater than those characteristic of mercantile occupancies. The fire load at the time of the fire in McCormick Place (Chicago, January 16, 1967) was estimated to be between 10 and 15 psf (49 and 73 kg/m²). With such a combination of fire loading and a large human population, there is every reason to require special protective measures in these buildings. This will be discussed in more detail later in this chapter.

Passenger terminals also present a problem in determining a reasonable estimate of the expected fire load. Ticket and waiting room areas would be expected to have a light fire load, yet the other uses in modern terminals such as stores, restaurants, and newsstands can result in combustibles as high as 10 to 15 psf (49 to 73 kg/m²). Special code provisions for modern terminal structures are certainly warranted in codes but have not yet been developed.

Although the combustibles in restaurants, cabarets and night clubs are not likely to exceed 10 pounds per square foot (49 kg/m²) of floor area, they have been classified into a separate grouping because of unusual life safety hazards.

Characteristic Hazards to Occupants—The hazards in assembly occupancies are far greater than is suggested by the low combustible content characteristic of this classification. Where large groups of people are in unfamiliar surroundings, often poorly illuminated, panic may result should a fire situation be perceived as trapping them. That panic situations rarely occur attests to the effectiveness of regulations intended to prevent them.

Where stages are equipped with movable scenery or where combustible interior finish or decorations are used, there is a greater probability of rapid fire growth. Despite the fact that fires in places of assembly may result in little property damage, they have accounted for an appalling number of human casualties. The fire record of theaters, night clubs, and similar uses gives vivid testimony to this fact.

Special regulations applicable to the construction of theaters and similar places of assembly include requirements relating to exits, interior finish, seating arrangements, partitions, stage construction, and sprinklers. These safeguards should specifically address special exit facilities, prohibition of the use of highly combustible interior finishes and decorations, and regulation of such other finishes and contents that may develop smoke or toxic gases when exposed to heat. These factors are all of special importance in minimizing the danger of panic in places of assembly.

Because the occupant load in stadiums, grandstands, amusement park structures, and air-supported structures is subject to extreme changes which create unique egress problems, special provisions are required in building codes. NFPA Standard for Assembly Seating, Tents, and Air Supported Structures, NFPA No. 102, containing the special provisions for outdoor assembly occupancies is referenced by most building codes for these structures.

Business Occupancies

Business occupancies are broadly defined as those facilities that are used for the conduct of financial, managerial, technical and other activities related to the operation of business, commerce or services. Typical business occupancies include offices of all types, computer and data processing facilities, information and other public service activities (including civic administration buildings and police and fire stations), banks and financial institutions, telephone exchanges, radio and television stations, and out-patient clinics and medical offices. Facilities for storage and maintenance of records and files are also included in the business occupancy classification.

It is of interest to note that the BCMC proposed classifications has placed educational uses above the 12th grade (college and university classrooms) in the business use group. The reason for doing so is because the typical college educational building more closely resembles the business or office occupancy. Of course, large lecture halls and similar high-occupancy rooms would be classified as assembly uses within the building.

Combustible Contents—The surveys by NBS conducted in 1974 and 1975 obtained fire load data on 23 office buildings located in various regions throughout the United States. According to the data published in NBS Building Science Series No. 85, business occupancies have uniformly low combustible content except in areas used for filing, storage and libraries.

In the survey data, the total weight of the combustible contents of filing cabinets, lockers and shelves, were included. However, NBS Report BMS 92 states, "where combustibles are stored in steel or equivalent incombustible containers, a corresponding corrected weight should be used in determining expected fire severity." Reduction of the fire load, called "derating", adjusts for reduced contribution if the combustibles are enclosed in such containers or in cabinets and shelves.

Table 5, reproduced from the data in BMS 92, shows the effective percent of combustible contents stored in noncombustible containers that can be assumed as contributing to the fire load.

Table 5—Derating Factors to Determine Combustible Contents of Steel Furniture

Type of Container	Percent Contribution to Fire Load		
	Proportions of Total Combustibles in Steel Containers		
	0 to ½	½ to ¾	¾ to 1
Filing cabinets and desks	40	20	10
Backed and partitioned shelving	75	75	75
Shelving with doors and transfer cases	60	50	25
Safes and cabinets of 1 hour or more fire-resistance rating	0	0	0

The NBS figures show, for example, that where more than three-fourths of the combustibles are enclosed in steel filing cabinets or in steel desks, the “effective” contribution of such enclosed combustibles is represented by only 10 percent of their weight. For such conditions, 90 percent can be deducted from the actual weight of enclosed combustibles when estimating their potential fire load.

Table 6 is derived from data appearing in the NBS report BSS 85 and represents a fire load profile of general and clerical offices.

The BSS 85 Report shows that the derated fire load in office buildings is less than 7 psf (34 kg/m²) of floor area and the derated fire load is approximately 90 percent of the total combustible load, Table 6. In office areas where quantities of combustibles are not stored in metal files or containers, it may be advisable to classify these areas as moderate hazard storage.

Characteristic Hazards to Occupants—Normally, a business occupancy, such as an office building, is fully occupied only during the daytime. In addition, most occupants are adults who are awake and sufficiently familiar with the premises to be able to make a fairly prompt exit from a fire area once an alert is given.

Table 6—Profile of Office Fire Loads
General and Clerical Offices
Sample size = 1044 offices

		Mean	Standard Deviation
1. Total fire load	=	7.3 psf	4.4 psf
2. Total fire load (derated)	=	6.6 psf	4.1 psf
3. Movable contents fire load (derated)	=	1.6 psf	0.5 psf
4. Interior finish fire load	=	1.6 psf	4.0 psf
5. Percent of total derated fire load enclosed in metal containers	=	9.1%	12.4%
6. Percent of total fire load that is paper and books	=	38.6%	22.9%

(Only those rooms that were randomly selected were used for the table.)

Considering the number of persons who occupy office buildings, loss of life in this occupancy has been small. Daytime fires are usually discovered at a sufficiently early stage to permit ample warning for the occupants. A safe, orderly exit can be made more readily under these conditions.

Evacuating the occupants from tall office buildings, however, does present some special problems. The time required and fatigue resulting from walking down many flights of stairs are factors that additional means of egress would not overcome. An alternative to evacuation is the creation of safe areas of refuge for occupants of upper stories of high rise buildings. These requirements are discussed in Chapter 5.

Educational Occupancies

Educational occupancies have generally been defined by codes to include schools, academies and similar uses. Those types of facilities used as day care centers, nursery schools, and kindergartens are usually included in the Educational Occupancy group. Space used for educational purposes which are incidental to another major occupancy is excluded.

Most codes define educational occupancies as those having six or more students on the premises at one time. The proposed BCMC definition uses the term "six or more persons" and includes only schools through the 12th grade. College and university buildings are classified as business occupancies.

Combustible Contents—A number of surveys of schools have shown that the fire load—represented by combustible contents—is relatively light. These data, first published in NBS Report BMS 92 were also summarized in the NBS Report BMS 149, Combustible Contents of Buildings. Table 7 includes the relevant data from these reports.

These data indicate that the movable combustible contents of schools usually ranges from a little below 3 psf (15 kg/m²) of floor area for classrooms and lecture rooms, up to about 7 psf (34 kg/m²) for rooms used for special instruction purposes. Except where heavy filing cases,

Table 7—Fire Loads in Educational Occupancies

Room Use	Average Combustible Contents (psf)				
	Average Floor Area	Movable Property	Floors	Exposed Woodwork Other Than Floors	Total
Typical Classroom	752	2.3	2.4	2.3	7.0
Laboratories: biology, chemistry, physics, food, and clothing	1038	4.5	2.1	1.5	8.1
Special Classrooms: art, bookkeeping, mechanical drawing, typing, physics lecture, wood-working shop, library reading room	1335	6.2	2.3	1.9	10.4
Offices: home economics, publications, teachers	342	8.0	3.1	3.1	14.2
Library Stackroom	264	28.4	2.1	5.4	35.9
Office and Files	276	36.3	2.6	0.1	39.0
Storerooms:					
Paint	184	4.0	2.6	13.1	19.7
Janitor	353	35.9	0.9	1.5	38.3
Lumber	480	43.7	1.3	0.7	45.7
Paper	425	97.5	0.0	0.7	98.2
Textbook	590	172.3	0.7	0.6	173.6

library stacks, and storage of text books or combustible materials were involved, the total combustible load was found to be less than 10 psf (49 kg/m²) in over 90 percent of the entire floor area of the buildings surveyed. The combustible load exceeded 15 psf (73 kg/m²) in less than five percent of the floor area.

In general, schools having a conventional distribution of regular classrooms and special instruction rooms such as laboratories and shops can be expected to have a fire load averaging somewhat less than 8 psf (39 kg/m²). This figure includes the combustible contents as well as floors, doors, windows, molding and trim, but not combustibles in the structural framing.

Storerooms and library stacks involve fire loads more commonly associated with storage occupancies and should be classified accordingly. Usually, code requirements for mixed occupancies are applied to such supplementary storage areas.

Characteristic Hazards to Occupants—An educational occupancy can be considered to be an aggregate of rooms, each housing a moderate number of persons of essentially the same age. Some codes divide the educational classification into two subcategories: elementary and higher-grade schools. However, one cannot ignore the possibility that the nature of the school occupancy may change from elementary to a higher grade, or vice versa, from one year to the next.

Furthermore, in both elementary and high schools the occupants are under continuous adult supervision. Fire drills and the degree of supervision in these schools introduce an element of safety that tends to offset the age factor. Consequently, it is debatable whether differentiation with respect to age of occupants in educational occupancies is justified.

The need for exercising special precautions to safeguard the lives of school children is widely recognized. Some serious losses of life have resulted from fires in schools, and even where loss of life is avoided, the social and economic losses that result are an important consideration.

The use of noncombustible members in the structural frame, roof, floors, walls, and partitions of a school building eliminates a major part of the fuel in the structure. Such construction minimizes the possible spread of fire over combustible surfaces and within concealed spaces.

One or two story school buildings of unprotected noncombustible construction in which occupants of classrooms and assembly areas are provided with adequate exits are now recognized by building and fire authorities as being particularly suited to meet present requirements for

building flexibility and economy. Many building codes have been revised to permit larger floor areas for school buildings of such construction, and some codes eliminate floor area limitations altogether for one-story schools where noncombustible construction is used.

Factory-Industrial Occupancies

The factory-industrial occupancy classification in building codes includes building uses such as manufacturing, assembling, fabricating, finishing, processing or packaging of materials or products other than those considered to be hazardous. Because of the wide range of combustibles and fire hazards which may be associated with industrial operations, it is usual code practice to establish more than a single class for factory-industrial occupancies based on the expected fire load. The proposed definition recommended by BCMC follows this practice and establishes two levels of factory-industrial occupancies including a listing of the many common uses associated with each. See Appendix A for the BCMC listing.

Combustible Contents—The degree of fire hazard of the contents can range from almost zero for a structural steel fabricating plant or a bottling plant to a very high load for a mattress factory. Even within a single industrial occupancy, the combustible load may vary so widely that the assumption of an average load for an entire factory can be quite misleading. NBS Report BMS 149 covers surveys of the combustible contents of six factories (two furniture factories, two mattress factories, a women's clothing factory, and a men's clothing factory) and two printing plants (one newspaper plant and one job printing plant).

In the two furniture factories surveyed, combustible loads in the working areas ranged from less than 5 to almost 65 psf (24 to 317 kg/m²). Certain small storage areas, representing less than 5 percent of the total floor area, had fire loads higher than 65 psf (317 kg/m²). Overall, however, less than 10 percent of the floor area in these two buildings had a combustible load of more than 30 psf (146 kg/m²).

Only a few areas in the two mattress factories had combustible loads greater than 30 psf (146 kg/m²). A cotton warehouse adjacent to one of these mattress-manufacturing plants had a much higher fire load. This was, however, a separate building and, as the NBS report states, baled cotton burns at a relatively slow rate. Over half the total area at both factories had fire loads amounting to less than 10 psf (49 kg/m²).

In the two clothing factories, 90 percent of the measured areas had

fire loads less than 15 psf (73 kg/m²). Only limited storage areas in one of these factories had loads that were more than 30 psf (146 kg/m²).

In the newspaper plant, 85 percent of the area had fire loads less than 40 psf (195 kg/m²), and in the general printing plant only the warehouse and storage areas were found to have fire loads exceeding 40 psf (195 kg/m²). The latter areas represented about 35 percent of the plant's total floor area.

As a result of the difficulty of assigning a single occupancy fire load value to cover all factory-industrial occupancies, the classification has been divided into low- and moderate-hazard groups. In general, the low-hazard group is considered to have a fire load of less than 10 psf (49 kg/m²) and the moderate-hazard group, a fire load ranging from 10 to 25 psf (49 to 122 kg/m²).

Certain industrial buildings, because of their construction, operation and content, have very little fire hazard. Typical of such occupancies are steel mills, cement plants, buildings used for the processing of noncombustible materials only, and power-generating plants. These need not be subject to limitations on building size if the structures themselves are noncombustible. These occupancies which have special functional requirements for layout, overhead clearances, ventilation, heating, lighting and entrance and exit ways, are not easily adaptable to change of occupancy without undergoing extensive structural or operational modifications. Further, their operations are subject to specific state industrial and safety regulations and the public is either excluded or permitted access only under close supervision.

It is impractical to include detailed provisions in codes for such special occupancies and, therefore, they are usually exempt from the conventional requirements of height, area and exit-distance limitations.

Characteristic Hazards to Occupants—The occupants of industrial buildings are adults, awake and alert during the time they are in the building. Thus, adequate fire safety can be obtained with less stringent protective measures than are needed to safeguard the occupants of residential, educational, or institutional buildings. However, if the higher combustible content of some industrial occupancies result in greater fire hazard, building heights and areas should be limited and supplementary fire protection measures required.

Hazardous Occupancies

Occupancies classified as hazardous include operations that store,

process, or handle highly combustible, flammable, or explosive solids, liquids, dusts or gases. Buildings used for this occupancy require more restrictive building regulations than any other occupancy group.

The characteristic that sets hazardous occupancies apart from all others is the increased level of danger to the community. In addition to a possible high fire load, the use or production of materials that are extremely combustible, explosive, highly corrosive, subject to spontaneous ignition, or release highly toxic fumes are included in the hazardous occupancy classification.

Because of the wide range of conditions found in hazardous occupancies, many special regulations are necessary for the kinds of equipment used. Customarily, cities and other jurisdictions adopt a fire-prevention code which regulates the installation, operation and maintenance of equipment in hazardous occupancies.

Since hazardous occupancies have the greatest potential risk to life and property, special safeguards for both the building and its occupants are essential. These may include installation of an automatic fire-extinguishing system, restrictions on building location, or special limitations on allowable floor areas, heights or even the type of construction.

In hazardous occupancies where there is a likelihood of explosion, automatic venting will help minimize building and content damage. Such venting may range from easily dislodged panels to entire walls that are secured only by shear pins designed for that purpose. The intent is to permit rapid dissipation of explosion-induced pressures thereby avoiding structural damage or failure.

The National Fire Codes of the National Fire Protection Association contain standards and recommendations for many hazardous processes and occupancies. While the regulations deal mainly with equipment operation and maintenance, they also include some provisions concerning construction requirements.

In the definition of hazardous occupancies, the types of hazardous materials are also defined and properties such as flashpoints and vapor pressures are specified. Certain hazardous materials in limited quantities may be permitted in some areas without designating the entire operation as a hazardous occupancy. These exempt quantities and the types of uses are usually specified in the code.

The BCMC definitions of hazardous materials and exempt quantities are included in Appendix A.

Institutional Occupancies

The institutional occupancy classification covers two basic groups of building uses. These are penal or detention type facilities, where the occupants are confined or under some degree of restraint, and health care facilities such as hospitals, sanitariums, and nursing homes. The institutional occupancy are generally considered to provide sleeping accommodations for 24 hour use.

The health care type occupancy is further subdivided into two groups based upon the assumed mobility of the occupants. The basic distinction between the two groups centers on whether the occupants can exit the building without physical assistance (ambulatory), or are physically or mentally impaired and therefore require assistance (nonambulatory). Facilities providing full time care for six or more children under the age of six are considered to be a nonambulatory occupancy.

The recommended definition for institutional occupancies as proposed by the Board for the Coordination of the Model Codes is included in Appendix A.

Some confusion has developed in the occupancy classification of child care and day care facilities. Day care facilities are those for the care of children less than 18 years of age for a period of less than 24 hours per day and where six or more children are accommodated. They are classed as Educational Occupancies. Child care facilities are those for the care of six or more children less than 18 years of age on a 24 hour daily basis (full time) and are classified as Institutional.

Combustible Contents—The extremely low combustible contents found in hospitals has been verified by a number of surveys. Investigations of three New York State hospitals showed that the weight of all furnishings, combustible and noncombustible, in patient wards averaged between 3.0 and 4.3 psf (15 and 21 kg/m²) of floor area. Additional data obtained in a survey (NBS Report BMS 92) of three other hospitals showed this figure to be conservatively estimated at 5.7 psf (28 kg/m²) as summarized in Table 8. For each item, the highest of several average values noted in the NBS report is given.

In general, the data shows that the weight of combustible contents averaged less than 5 psf (24 kg/m²) over almost 90 percent of the floor area while density greater than 10 psf (49 kg/m²) existed in only 4 percent of the total floor area.

Jails, prisons and similar detention facilities generally have their contents controlled in order to maintain a very low potential fire load.

Even in low security facilities, the furnishings normally do not exceed that found in residential occupancies.

Characteristic Hazards to Occupants—In nonambulatory type of health care facilities such as hospitals and in penal institutions, it is assumed that the occupants will have to be protected in place or else be moved a short distance to an area of refuge in the event of a fire. For this reason, noncombustible and fire-resistive construction is essential for

Table 8—Fire Loads in Institutional Occupancies

	Average Combustible Contents (psf)		
	Movable Property	Exposed Woodwork and Floors*	Total
Rooms (single)	0.5	3.2	3.7
Corridors	0	2.6	2.6
Waiting Rooms	1.7	1.5	3.2
Janitors' Closets and Supplies	3.1	3.4	6.5
Doctors' Offices	5.7	2.9	8.6
Nurses' Offices and Rooms	3.1	1.9	5.0
Nurses' Infirmary	0.8	2.2	3.0
Diet Kitchens and Dining Rooms	1.2	2.4	3.6
Laundries	4.4	0.6	5.0
Laundries and Clothes Storage	12.5	0.6	13.1
Dormitories	0.8	2.0	2.8
Pharmacy, Dispensary, and Stores	5.8	1.9	7.7
Lockers, Toilets, Barber Shops	0.2	1.2	1.4
Approximate Average of Entire Usable Floor Area of Three Hospital Buildings Surveyed			5.7**

*Combustible floor finish, where present, was ¼-inch-thick linoleum, assumed to be the equivalent of 1 pound of combustible material, such as wood, per square foot of floor area. Doors, windows, trim, molding, baseboards, etc. are included.

**This approximate average weight was computed from Table 16 on page 25 of the NBS Report BMS 92. The value is somewhat high because only the highest weight in each bracket of combustible contents was used, i.e., in the bracket "0 to 4.9 lbs. per sq. ft.," the value 4.9 pounds was applied to the indicated area, etc.

fire safety regardless of the size of the facility. Fire-resistive separations between patients' rooms and corridors and adequate enclosure of stairs and shafts serve to provide areas of refuge and protect the occupants from effects of fire and smoke. The incorporation of smoke detectors, smoke-stop partitions and automatically closing smoke-stop doors in corridors and other areas of refuge can effectively reduce the hazards associated with most institutional fires.

Mercantile Occupancies

Because of the higher combustible contents and occupant density associated with retail and wholesale stores and sales rooms, it is logical to establish a separate occupancy classification for the mercantile type facility rather than include it in the business classification. The BCRC recommendations follow this practice.

Combustible Contents—Stores, shops, salesrooms, and similar retail and wholesale occupancies contain stocks of merchandise for display and sale that have combustible contents of greater average weight than the contents of office buildings or other business occupancies. NBS Report BMS 149 summarizes the fire load information obtained from surveys of two large mercantile buildings, one located in New York City and the other in Washington, D.C. The following is excerpted from this Report:

“For four floors of the New York City store the average was below 10 pounds per square foot and for the six others the highest average for any one floor was 13.4 pounds per square foot. In the Washington, D.C. store the average was not over 10 pounds per square foot for the six floors, and the highest individual average for the two other floors was 12.6 pounds per square foot.

“It is seen that 50 to 60 percent of the floor area had combustible contents not over 10 pounds per square foot, from 30 to 35 percent had between 10 and 15 pounds per square foot, 10 percent had between 15 and 20 pounds per square foot, and no more than 5 percent of the area had more than 20 pounds per square foot.”

Comparable surveys made in other cities have confirmed these findings. Four large department stores in Pittsburgh had a combustible content ranging from 2 to 20 psf (10 to 98 kg/m²) of floor area and averaged close to 8 pounds (39 kg/m²) for all four buildings. A large Chicago department store reported that it averaged 7 to 8 pounds (34 to 39 kg/m²) of combustibles per square foot of area, including cabinets and shelving.

A building occupied by a large chain grocery, meat, and produce

distributor had a combustible content averaging between 4 and 5 psf (20 and 24 kg/m²) of floor area. This did not include goods in metal cans but did cover cereals and furnishings.

From the foregoing data, it can be reasonably assumed that the combustible contents of stores, shops, salesrooms, and similar mercantile occupancies can be expected to average about 10 to 20 psf (49 to 98 kg/m²) of floor area.

Characteristic Hazards to Occupants—There have been relatively few fires in mercantile occupancies resulting in large loss of life. However, potential danger to life was demonstrated by the department store fire in Brussels, Belgium, on May 27, 1967, in which 300 lives were lost.

Special fire-safety precautions are necessary in the mercantile occupancy, particularly in the larger department stores where a large number of people can be expected on the premises during normal operating hours. The most important precautions are those that provide adequate exit facilities with fire-resistive enclosures, and automatic fire-extinguishing equipment.

Covered and enclosed malls, where a number of separate stores may be connected by a common roof, have some unique life-safety problems which are discussed later in this chapter.

Residential Occupancies

The residential occupancy classification includes those facilities designed to provide sleeping accommodations for normal residential purposes. It is divided into three sub-classifications to provide different degrees of fire protection based on occupant density. For example, hotels and motels are included in one group, multiple dwellings and apartments in the second group, and one- and two-family dwellings in the third.

The proposed BCMC definition for residential occupancies is included in Appendix A.

Combustible Contents—Residential occupancies are generally found to have a low average weight of combustible contents. The surveys reported in the NBS Report, BMS 92, show that movable combustible furnishings and contents of residential buildings average only 3.4 psf (17 kg/m²) of floor area. The total combustibles represented by the furnishings plus floor finish, doors, windows, trim, moldings and

shelving, average 8.8 psf (43 kg/m²). A study conducted by a major hotel chain to determine the total design load requirements for hotel buildings showed that the furniture, combustible and noncombustible, in a typical hotel guest room, weighed 812 pounds (368 kg) or about 4.1 psf (20 kg/m²) of floor area. Modern residential buildings may have less combustible contents than older structures because of the tendency to use lighter and smaller amounts of interior finish and trim. The increased standardization of design in newer hotels may lower the combustible content per room.

While closets may contain concentrations of combustibles considerably higher than the averages, the total area of these spaces represent only a very small percentage of the total building floor area. In determining the fire load for a particular room, the concentrations due to closets are included in the average weight of the combustibles for the rooms they serve.

Table 9, showing weights of combustible content in dwellings and apartments, was prepared from survey data given in NBS Report, BMS 92. It should be noted that this report was published in 1942 and most of the data were obtained some years prior to that time.

The following summary appears in the NBS Report:

“In apartments and residences, even with combustible floors and other woodwork, the amount of combustible content was found to be relatively light with an average below 10 psf of floor area.”

The fire load in buildings designed for use as residential occupancies, exclusive of the structural components, may be assumed to average less than 9 psf (44 kg/m²) of floor area. The combustible contents account for approximately 6 psf (29 kg/m²) while combustible trim, shelving, moldings, may add another 3 psf (15 kg/m²).

Characteristic Hazards to Occupants—Fire in dwellings result in nearly 4 out of every 5 of the fire related deaths in all occupancies reported to NFPA. The number of lives lost per individual dwelling fire usually is low, since occupancy is limited. As a consequence, such fires do not get the publicity that is accorded the large losses of life from fires in larger structures, such as night clubs, hotels and schools.

The category “Occupants of Residential Buildings” includes everyone from infants to the aged, sick or healthy. Most are asleep for approximately one-third of every twenty-four hours. It is under such circumstances, where fire has an opportunity to spread before being

discovered, that more than half of all residential fire deaths have occurred.

In private one- and two-family dwellings, where loss of life is greatest, there is the least control over contents and behavior of the occupants and, therefore, requirements for structural fire safety in these occupancies will not significantly affect these factors. However, in multi-family structures and hotels, requirements for certain structural protection features can be most effective in confining a fire and providing for safe egress from the building.

There are other features of building construction including installation of heating and electrical systems that can have a significant effect in reducing the incidence and severity of fires. When a fire originates within concealed combustible spaces of residential structures, the op-

Table 9—Fire Loads in Residential Occupancies

Dwellings and Apartment Buildings	Average Combustible Contents (psf)			Total
	Movable Property	Floors	Exposed Woodwork Other Than Floors*	
Bedrooms (including closets)	5.0	2.8	2.6	10.4
Dining Rooms	3.2	2.0	2.0	7.2
Hallways	1.0	3.0	6.5	10.5
Kitchens	1.2	2.5	3.1	6.8
Living Rooms	3.9	2.4	1.8	8.1
Store Rooms (apartment houses)	6.4	0.5	0.3	7.2
Closets—				
Clothes (average area 8.75 sq. ft.)	5.1	2.7	11.6	19.4
Linen (average area 4.77 sq. ft.)	11.7	3.0	21.4	36.1
Kitchen (average area 5.0 sq. ft.)	4.0	3.0	23.2	30.2
Entire Apartment or Residence— (average for all areas surveyed)	3.4	2.6	2.8	8.8

*Includes doors, windows, baseboards, moldings, trim, shelving, etc.

portunity for the fire to spread undetected is enhanced unless adequate fire stopping and cutoffs are provided. Fires caused by faulty electrical wiring or heating equipment, or flues or chimneys, may spread undetected in combustible crawl spaces, attics, and plumbing chases and may develop into large fires before the occupants become aware of the danger.

Storage Occupancies

The storage occupancy classification includes a broad range of facilities where commodities and goods, packaged or otherwise, are stored. Generally, storage occupancies have been classified into two sub-groups: moderate hazard storage where products and possibly containers are combustible, and low hazard storage where the products are usually noncombustible but may be stored in combustible wrappers or cartons which represent a low or negligible amount of fuel.

The recommended BCBC definition for storage occupancy is included in Appendix A.

Combustible Contents—Storage occupancies are subject to a wide range in the quantity of combustibles that may be present. The degree of fire hazard of the contents may range from almost zero to extremely high values for buildings storing packaged food or rolled newsprint.

The low hazard storage classification is usually assigned to those occupancies having a fire load less than 10 psf (49 kg/m²); the moderate hazard storage classification to those having a fire load ranging from 10 to 25 psf (122 kg/m²).

If storage buildings were required to be designed to have a fire resistance sufficient to withstand the maximum fire severity that the fire load represented, then the result of a fire might only be destruction of the contents within an essentially undamaged structure. Since the contents may be far more valuable than the building, and this is usually the case, a better option would be the utilization of measures to protect the contents and extinguish fires before they threaten the structure itself. There can be economies in design resulting from incorporating automatic extinguishing systems in storage occupancies in lieu of providing passive fire resistance for the anticipated fire load. Fire-load measurements indicate that those in excess of a two-hour fire severity are the exception and, for these situations, supplementary non-structural measures such as automatic fire extinguishing systems should be required.

Characteristic Hazards to Occupants—As in the case of industrial occupancies, the occupants of storage use groups are usually a limited number of adults and are assumed to be alert and mobile during the time they are in the building. Thus, adequate life safety can be obtained with less stringent protective measures than is required for other occupancies.

Because storage occupancies are normally occupied by only a few people, it is important that automatic protection and alarm systems be provided to assure early warning and extinguishment in case of fire.

Utility and Miscellaneous Use Occupancies

To cover those occupancies which do not fall into a specific occupancy classification and are usually not habitable, a utility and miscellaneous use group has been included in most codes. Inasmuch as it does not represent a habitable occupancy, there is little concern for expected fire load or its hazard to occupants. Utility and miscellaneous use groups would include accessory structures such as carports, sheds and agricultural buildings, as well as fences, tanks, cooling towers and retaining walls. There is no need to assign any specific fire load category to such uses nor is there any need to provide any special exiting or occupancy requirements. For the types of enclosed structures covered under the utility and miscellaneous use groups, codes usually limit the area of these buildings to 1000 square feet (93 m²) or less.

Special Occupancy Requirements

Fire protection requirements for buildings that house occupancies having unique characteristics are generally described in separate building code sections. These special provisions apply to structures which because of unusual architectural requirements, extremely light hazards, or designed for a specific operation or process, require regulations that vary considerably from those established for conventional occupancies. The discussion that follows concerns itself with the characteristics and recommended requirements applicable to some special occupancies covered by building codes.

Automobile Parking Structures—The expansion of automobile use near mercantile and business centers, sports arenas, and transit facilities has created great demand for parking facilities. Where land costs are high or available space is limited, multi-storied off-street parking structures offer a feasible solution to the parking problem.

In the past, parking structures for automobiles were required to meet fire-resistive restrictions far in excess of the fire load or fire severity that existed. The National Fire Protection Association in their book, *Fire Safety in the Atomic Age*, included an analysis of the fire problem in parking structures. This study made the assumption that every car had a full tank of gasoline and that a full structure of closely parked cars represented the prevailing storage conditions. Under these circumstances, it was calculated that the calorific fuel content converted to the equivalent wood or paper content (8,000 btu per pound) (18608 kJ/kg), averaged less than 2 pounds per square foot (10 kg/m²) of floor area—a very low fire load. Although this reference is fairly old, the hazard has remained essentially unchanged. More recent studies in Great Britain, Japan and the United States confirmed the NFPA conclusions.

A full-scale fire test in a modern operating, multi-storied open-air parking structure with exposed steel structural members, was conducted in 1972 by American Iron and Steel Institute to study the effects of an automobile fire on the integrity of an exposed steel frame building. Three automobiles were parked adjacent to each other. A fire was set in the center vehicle and allowed to burn unrestricted. All three cars were American-made, full-size sedans, and each fuel tank contained 10 gallons (37.9 liter) of gasoline. Windows of all cars were partially open to aid combustion and fire spread. After a period of 48 minutes the test car was completely gutted but neither of the adjacent cars were significantly damaged. The maximum temperatures of the structural steel in the building remained far below critical levels throughout the entire test period, and none of the structural steel was damaged or even deflected seriously. On the basis of this test, and those conducted in Japan and Great Britain, it was concluded that open-air parking structures represented an extremely low fire hazard and that its exposed steel framing does not require structural fire protection.

Surveys of fire experience in automobile parking structures in the United States and Canada conducted for American Iron and Steel Institute by Marketing Research Associates showed that fires in open parking structures seldom occur and that individual fires in cars seldom spread to other cars.

These investigations of parking structure hazards have provided building authorities with the basis for the formulation of safe and feasible provisions that now appear in all modern building codes. Open parking structures, because of their design, permit easy access for fire fighting and ample openings to allow dissipation of smoke and combus-

tion gases. For these reasons, greater height and areas are permitted by all modern codes for unprotected noncombustible parking structures when the exterior walls are left open.

Exhibition Halls—Following the disastrous McCormick Place Fire in Chicago on January 16, 1967, building officials became concerned with the formulation of specific requirements governing such structures. This occupancy combines the life-safety characteristics of an assembly use with the fire load characteristics of a mercantile building.

Commercial or industrial exhibitions are temporary operations which for brief periods of time contain large quantities of goods that have a high value and, possibly, high combustibility. During these periods a large number of persons may occupy the premises. The fire load at an exhibit may be as great as 20 pounds per square foot (98 kg/m²) and may be arranged in a manner as to burn very rapidly. Moreover, with the temporary nature of the displays, material and booth furnishings can be erected and dismantled hastily, and therefore do not undergo the scrutiny that might be applied to more permanent exhibit arrangements.

Even though exhibition halls are classified as assembly occupancies, added provision should be included in codes to take into account the fire load and hazardous characteristics of this occupancy. Provisions in most modern codes require that an automatic fire extinguishing system be provided in those parts of an assembly building used for the display of combustible materials when such areas exceed 15,000 square feet (1394 m²).

Covered or Enclosed Malls—The development of large covered or enclosed shopping malls has created a need for additional building code criteria. The enclosures themselves introduce hazards to life and property that have not previously been fully recognized or evaluated.

In the context of fire protection regulations, the term “covered mall” means not only the space between stores and other occupancies opening onto the mall but also the structures housing the stores and other property uses. The fire protection requirements for enclosed malls should provide for safe egress from the mall area and the adjoining buildings. Fire hazards in the mall area such as combustible displays should be restricted. Individual stores as well as the buildings joined by the mall construction should be separated by suitable fire-resistive construction.

Location of exits from individual tenant spaces should be such that occupants are not compelled to use the mall area as the only means of egress. Adequate and separate means of egress should be provided for the occupants of the buildings. Regardless of other exit facilities, the mall area itself should have at least two widely separated routes for egress, both of which lead directly to the exterior. Malls should also have permanent and adequately sized roadways around their perimeters to allow access for fire department apparatus.

The allowable area and construction type used in a mall enclosure itself should be based on the proposed use of the mall area. If, for example, the mall area is used for retail sales, then the entire area of the mall and adjoining buildings should be considered as one building, and its construction regulated according to applicable code provisions. Provisions should be made for the venting of the smoke and heat from the mall enclosure, so that the area will not become untenable in the event of a fire in one of the connected buildings or mall stores. When the mall is built of combustible construction or contains combustible materials, the building walls facing the mall interiors should be constructed as fire walls. As an alternate, an automatic fire extinguishing system may be installed in the mall and in the buildings adjoining the mall.

Buildings for High-Stacked and Rack Storage—Increasingly, tall structures are being used for warehousing materials and products. They permit goods to be stacked to heights equivalent to four-storied buildings or higher. If these materials are combustible, the fire loading may exceed by many times the loading usually associated with conventional warehouses. Most high-stack storage complexes are equipped with fairly elaborate materials handling systems, and the value of the contents in such a structure can be extremely large. Structural fire protection would, at best, only preserve a fraction of the exposed value while permitting the contents to be destroyed. Early fire detection and a quick extinguishing system are the only means of minimizing fire loss and protecting the structure and contents.

Recommendations for materials storage and for general commodity classifications are given in Standard for Rack Storage Materials, NFPA 231C. These provisions apply to stored materials over 12 feet (3.7 m) in height on racks. The standard does not cover storage of materials on plastic pallets or plastic shelves, nor does it cover the storage of high hazard materials such as tires, plastics and flammable liquids.

Summary

Most occupancies are classified under one of the occupancy groups mentioned in this chapter. Determination of the appropriate occupancy classification is made on the basis of the quantity of combustibles normally attributed to the buildings use and the associated life-safety characteristics. The occupancy groups, the estimated fire loading and the corresponding fire severity of the use group are shown in Table 10.

Obviously, such groupings cannot include all the possible building uses, nor can mixed occupancies be covered in such a classification system. Hence, special code provisions are made for mixed occupancies, as well as for those that manifest unique characteristics in terms of fire load, types of materials handled, or equipment used within the structure.

The special occupancy requirements and provisions included in most modern building codes cover such uses as garages, aircraft hangars, stadiums, grandstands, amusement park buildings and structures, temporary structures, parking structures, power generating plants, steel mills, greenhouses and bowling alleys.

Table 10—Occupancies—Fire Load—Fire Severity

Occupancy	Combustibles in Occupancy (psf)	Fire Severity (hours)
Assembly	5 to 10	½ to 1
Business	5 to 10	½ to 1
Educational	5 to 10	½ to 1
Factory—Industrial		
Low Hazard	0 to 10	0 to 1
Moderate Hazard	10 to 25	1 to 3
Hazardous	Variable	Variable
Institutional	5 to 10	½ to 1
Mercantile	10 to 20	1 to 2
Residential	5 to 10	½ to 1
Storage		
Low Hazard	0 to 10	0 to 1
Moderate Hazard	10 to 30	1 to 3

References

AMERICAN IRON AND STEEL INSTITUTE, *Automobile Parking Structures*, New York, 1971.

—*McCormick Place Fire*, New York, 1968.

NATIONAL BUREAU OF STANDARDS, *Combustible Contents in Buildings (BMS 149)*, Washington, D.C., 1957.

—*Fire Resistance Classifications of Building Construction (BMS 92)*, Washington, D.C., 1942.

—*Survey Results for Fire Loads and Live Loads in Buildings (BSS 85)*, Washington, D.C., 1976.

NATIONAL FIRE PROTECTION ASSOCIATION, *Recommended Practice for the Protection of Library Collections from Fire, (NFPA No. 910)*, Boston, Mass., 1975.

—*Standards for Rack Storage of Materials, (NFPA No. 231c)*, Boston, Mass., 1975.

NATIONAL FIRE PROTECTION ASSOCIATION, "Fatal Store Fire, Brussels, Belgium", *Fire Journal*, Nov. 1967, Vol. 61, No. 6, pp. 5-8.

MARKETING RESEARCH ASSOCIATES, *Survey of Fire Experience in Automobile Parking Structures in the United States and Canada*, January 31, 1972.

1979 Update of the Survey of Fire Experience in Automobile Parking Structures in the United States and Canada, January 31, 1979.

EGRESS FROM BUILDINGS

Safeguarding life from the effects of building fires cannot be achieved simply by meeting design requirements that relate to the control of fire spread. When a fire starts, the occupants must be able to leave the building safely or, at the very least, move to areas into which fire and smoke will not spread. For these criteria to be met, the means of egress must be protected from both fire and toxic gases and all of the occupants must be able to reach a safe area (either outside or within the building) with minimum risk of injury or panic.

There is limited information published relating to the rate at which people move along corridors, stairways or through doorways. A report published in 1935, "Design and Construction of Building Exits," National Bureau of Standards (NBS) Miscellaneous Publication M151, was based upon surveys which measured the widths of corridors, doorways, and stairways in buildings that were erected within the ten years preceding the report. Rates of travel along exit routes, usually under normal occupancy conditions, were also measured and from these data recommendations for safe building exit design were formulated. They are still widely used in building codes. While much research has been and is being conducted to determine possible revisions to these criteria, none of the work has yet been reduced to suitable code "language."

During a period of years from 1913 to about 1918, the National Fire Protection Association (NFPA) Committee on Safety to Life published several separate standards for the construction of stairways, fire escapes, etc., for the conduct of fire drills, and for construction and arrangement of exit facilities for factories and schools. These standards were combined into the NFPA Building Exits Code in 1927. This code has had frequent revisions, including the incorporation of many recommendations from NBS M151. In 1966 it was completely rewritten into more formal code language, and it is now identified as the Life

Safety Code, NFPA No. 101. New editions are now published on a three-to-four year revision cycle.

Means of Egress—Definition

Most modern building codes use the terms “exit,” “exit access” and “exit discharge” in the definition of means of egress. The definition recommended by the Board for the Coordination of the Model Codes (BCMC), for means of egress is as follows:

“A continuous and unobstructed way of exit travel from any point in a building or structure to a public way and consists of three separate and distinct parts (a) the way of exit access, (b) the exit, and (c) the way of exit discharge. A means of egress comprises the vertical and horizontal ways of travel and shall include intervening rooms, spaces, doors, corridors, passageways, balconies, ramps, stairs, enclosures, lobbies, escalators, horizontal exits, courts and yards.”

The term “means of egress” has come to be used as the broad designation identifying the facilities provided for normal and emergency evacuation from any part of a building.

An “Exit Access” is the portion of the means of egress system which leads into the exit. The exit access, which is usually separated from the exit by a doorway, may be a corridor or an aisle or even a portion of a room.

An “Exit” is that portion of a means of egress which, by virtue of being separated from all other areas in a building by suitable construction, provides a protected way of travel to the exit discharge.

An “Exit Discharge” is the portion of a means of egress leading from the exit termination to the outside of the building or to a public way. It could be just the outside doorway to a street or it may include a fire-resistive passageway to the outside as well as the doorway.

These definitions are used in the Basic Building Code and the Standard Building Code. The Uniform Building Code includes all of these components in its definition of the word “exit.”

Exit Capacity

Egress routes can traverse such building areas as rooms, corridors, doorways, stairs, ramps and lobbies. There is no uniform rate of travel that can be consistently maintained when people move through these various spaces during the time of evacuation. For example, able-bodied people traveling along a corridor move at a speed about one-third faster than when going down a stairway. Doorways, furniture and other obstacles may also tend to impede the rate of travel. Further, there are

certain occupancies where the rate of travel may be slower because of the occupants' age, health, or physical disabilities.

As a convenient exit-design module, the term "unit width" has been adopted by building codes. Its numerical value is 22 inches (558.8 mm) and, according to the aforementioned NBS M151, it represents the mean width taken up by people moving in single file. Thus two unit-widths, 44 inches (1117.6 mm), are assumed to allow a double line to move freely along an exitway or downstairs at one time. In stairways, where railings are required, this width is measured from wall to wall. Where one side of the stairway is open, it is measured from the wall to the center line of the handrail or balustrade. When the total exit width is not an even multiple of 22 inches (558.8 mm), it is accepted practice to consider 12 inches (304.8 mm) or more as equal to one-half of the unit width for the purpose of determining the exit capacity.

Some initial studies conducted in Canada seem to indicate that the 22-inch (558.8 mm) module for units of exit width is not suitable for all conditions. These studies show that simultaneous use of a single stair tread by two or more persons is rare and that people will tend to move in such a way as will maximize the area available around each. Moreover, as congestion increases, the rate of travel decreases so that the actual capacity of an exit, in terms of the number of persons passing a given point per minute, may diminish as the crowding increases. With increasing volume the slowest element or the greatest constriction dominates the movement of the whole. In other words, the exit capacity does not depend on exit width alone, certainly not to the extent of assuming, as codes do, that doubling an exit width doubles the rate at which it will allow persons to leave a building. Reasonable alternates to the use of the 22-inch (558.8 mm) module and presumed rates of travel, however, have yet to be proposed for adoption in building codes. Hence, the earlier assumptions still govern major exit design criteria in the model building codes.

The number of exit unit-widths that should be provided can be determined from the anticipated population of the area served by the exits and the established rate of travel along the exit route. The rate of travel down stairways and ramps is generally assumed to be from three-fifths to three-fourths of the rate of travel along horizontal routes. Capacity per exit unit-width is expressed as the number of persons presumed to pass a given point during a one-minute period. Given all the above figures, a building's occupant evacuation time could be estimated, though no maximum time is specified in any code.

In multi-story buildings, exit capacity need not increase with the number of stories. The time required to descend from floor to floor and the capacity of the stairways to "hold" persons are assumed to be sufficient to require no increase in exit capacity with the number of stories. However, no exit should ever be reduced in width in the direction of exit travel. If it is anticipated that there will be more people occupying an upper floor than on the lower floors, the minimum exit-width for the largest number must be maintained through to the exit discharge.

The population of assembly, business, educational, factory-industrial, hazardous, mercantile, and storage occupancies are expected to be awake, alert and physically capable of leaving the fire area without assistance. Therefore, these occupancies are assumed to have the same allowable capacity of the exit unit-width.

The lower capacity per unit width required for portions of exits in institutional and residential occupancies is derived from the assumption that the occupants may be sleeping, restrained, or physically incapable of leaving the fire area without assistance. This, in part, compensates for the real possibility of delay in evacuation.

As previously noted, the required total exit width or exit capacity is based on the number of persons expected to be in the building (occupant load), and the assumed travel rate through each portion of the exit. The total occupant load per floor can be found by dividing the area per floor by the assumed occupant density (usually given in square feet per occupant). The number of units of exit width required can then be determined by dividing the occupant load by the capacity of the type of exit used.

Total occupant loads may be determined from the presumed area per person and the gross floor area or the net floor area of a building or portion of a building. Gross floor area usually means the entire projected area within the exterior walls of a building. Net floor area usually means the area actually occupied not including closets, hallways, foyers, etc.

Occupant densities and exit capacities are shown in Table 11, Building Occupancy Density, and Table 12, Capacity of Exits. The values in these tables are based on the recommendations of the Board for the Coordination of the Model Codes (BCMC) and are in substantial agreement with the Life Safety Code.

Building codes should include provisions that will give recognition to the requirements of a building that has an uneven distribution of

Table 11—Building Occupancy Density

Occupancy	Floor Area Per Occupant	
	ft ²	(m ²)
Assembly without fixed seats		
Concentrated	7 net	(0.7)
Standing Space	3 net	(0.3)
Unconcentrated	15 net	(1.4)
Assembly with fixed seats	Note 1	
Bowling alleys, allow 5 persons for each alley, including 15 feet of runway and for additional areas	7 net	(0.7)
Business	100 gross	(9.3)
Court rooms—other than fixed seating areas	40 net	(3.7)
Educational		
Classroom areas	20 net	(1.9)
Shops and other vocational areas	50 net	(4.6)
Hazardous	100 gross	(9.3)
Factory-Industrial	100 gross	(9.3)
Institutional		
Sleeping areas	80 gross	(7.4)
Inpatient treatment areas	240 gross	(22.3)
Outpatient area	100 gross	(9.3)
Library		
Reading rooms	50 net	(4.6)
Stack area	100 gross	(9.3)
Mercantile		
Basement and grade floor areas	30 gross	(2.8)
Areas on other floors	60 gross	(5.6)
Storage, shipping areas	100 gross	(9.3)
Parking garage	200 gross	(18.6)
Residential	200 gross	(18.6)
Storage	300 gross	(27.9)

Note 1: The occupant load for an assembly area having fixed seats installed shall be determined by the number of fixed seats.

occupants, or that may have a population distribution that cannot be expressed in a generalized figure. An example of this condition exists in schools where, at various times, assembly halls or dining areas are filled to capacity while other parts of the building may be vacant. In these circumstances, the Life Safety Code requires that where auditorium or gymnasium exits lead through corridors or stairways also serving as exits for classrooms the exit capacity should be sufficient to permit the simultaneous exit of both. However, where the auditorium or gymnasium facility is not intended for simultaneous use, then the exit capacity need only be designed to accommodate the greater occupant load.

Escalators and Elevators

Many building codes permit moving stairs to be used as required exits. They are subject to the same requirements as stairways for width, enclosure, and protection. This is reasonable, since moving stairs can function as a stairway despite a power failure. Nonetheless, only moving stairs that normally operate in the direction of egress and cannot be reversed should be considered as exits.

Building codes usually do not permit elevators to serve as part of the building's required means of egress because any power failure will immobilize the elevators and controls may malfunction even when designed for emergency operations. Most, if not all, elevators installed

Table 12—Capacity of Exits Per 22 Inch Unit Width

Occupancy	Number of Occupants	
	Stairways Escalators	Doors, Ramps,* Corridors
Assembly	75	100
Business	60	100
Educational	75	100
Factory—Industrial	60	100
Hazardous	30	50
Institutional	22	30
Mercantile	60	100
Residential	75	100
Storage	60	100

*Ramps with slope greater than 1 in 10 are considered to have the same capacity as stairways.

today are automatically operated and do not allow manual override control except by fire department or other authorized personnel. Passengers can become trapped and exposed to smoke or heat regardless of whether the elevator shafts are of fire-resistive construction.

While, in tall structures, elevators may offer the only reasonable means of egress, their use during emergencies should be discouraged. Building occupants should always be advised to use stairways rather than elevators if they must evacuate because of fire emergency. Most codes require that a permanent sign be installed in each elevator and at each elevator call station on every floor which reads: "IN FIRE EMERGENCY DO NOT USE ELEVATOR. USE EXIT STAIRS."

Total evacuation of tall buildings in an emergency may be a last resort as the time involved and the physical capabilities of all occupants to descend long, unfamiliar exit routes may make the success of such action unpredictable. Life safety design factors in these buildings include egress as only one of several options.

Exit Arrangement—Separation and Travel Distance

Proper location of the required exits throughout a building is no less important than their total number and width. Experience has shown that the location of exits should be based on the assumption that one or more may be unusable in an emergency due to smoke or heat. The broad requirement that exits be located remote from one another has been widely adopted so as to achieve this desirable end and at the same time allow maximum design flexibility. On the other hand, travel distance from any point to protected exits must be kept within reasonable bounds because they are expected to provide an area of refuge relatively free of smoke and heat.

The time required to reach an exit can be critical. Accordingly, maximum limits are established for the travel distance from any point to an exit. An exit by definition is that portion of the route of travel that leads to the exterior or to a refuge area and is separated from other portions of the buildings by some form of permanent construction, usually noncombustible and fire-resistive.

There is a lack of agreement among the various model building codes as well as the Life Safety Code as to the maximum allowable travel distance to exits. The Board for the Coordination of the Model Codes has recommended that travel distance be limited to 150 feet (45.7 m) for unsprinklered buildings and 200 feet (61 m) for sprinklered buildings used for any occupancy except a hazardous occupancy in which travel

distance is limited to 75 feet (22.9 m). BCMC also recommends that exceptions be permitted in individual buildings where large areas may require other special exit arrangements.

The Life Safety Code specifies a maximum travel distance of 150 feet (45.7 m) in unsprinklered buildings (200 feet (61 m) for sprinklered buildings) used for assembly and educational occupancies. A lesser maximum travel distance of 100 feet (30.5 m) (150 feet (45.7 m) for sprinklered buildings) is specified for residential, institutional, mercantile, and factory-industrial occupancies. The logic for a lower figure in these occupancies is unclear. In both residential and factory-industrial occupancies the density is considerably lower and the occupants can be assumed to be reasonably familiar with their surroundings. These conditions would seemingly warrant at least equal travel distance requirements to those specified for night clubs and theaters where rooms may be darkened and other conditions may exist which could cause confusion to the occupants in emergency situations.

Inasmuch as many of these factors are considered in development of other safety provisions of the code for the specific occupancies, it seems appropriate to establish a single standard travel distance requirement for all occupancies as has been done by the BCMC.

There does not seem to be a sufficiently valid reason for permitting up to a 50 percent increase in travel distance for buildings equipped throughout with an automatic sprinkler system. However, as discussed in Chapter 8, the increase in travel distance would not create the danger of pile-up at the exits as would possibly occur if an increase in exit capacity is allowed when a sprinkler system is provided.

Dead-End Corridors

Dead-end corridors and exit corridors that provide only a single path of travel are difficult to exclude from building design, but they do represent a particular problem from a fire safety standpoint. The possibility of a fire blocking the path of travel where an alternate route is not available and also the confusion that may occur in smoke-filled corridors are the main reasons why dead-ends should be avoided or their length severely limited. The BCMC recommendations have set the maximum length of dead-end corridors at 20 feet (6.1 m) for all occupancies. The Life Safety Code has established dead-end limits and single-path-of-travel limits ranging from 20 feet to 50 feet (6.1 m to 15.2 m) depending upon the occupancy.

Number and Design of Exit Facilities

Except in certain residential and business buildings of limited size, it is an accepted principle that every floor area have not less than two exits. Educational, assembly, institutional, and similar types of public buildings should always have at least two exits regardless of their size or type of construction.

Every exit or exit access, either from a room or floor area, should lead directly to a passageway, a stairway, or to the building exterior. When this is not possible, it may be necessary to route an exit access through an adjoining room. The assumption is that if the number of occupants in the adjoining room is relatively low, and each of the interconnected rooms is under the continuous control and supervision of some responsible authority, then this arrangement is acceptable. In a public building, for example, where all or nearly all the occupants are continuously alert, it is permissible for one door from a room to lead into an adjoining room that, in turn, has at least one door leading directly to an exit or to the building exterior. But in multi-family dwellings, hotels, or business buildings, where doors between the separate tenants are usually locked or otherwise obstructed, such an exception would not be permitted.

Institutional occupancies demand special consideration as to the location and design of exit facilities. The mental and/or physical condition of institutional occupants can be such as to preclude exit designs suitable for other occupancies. Infants, the disabled or retarded, the bedridden, the mentally ill and inmates of penal institutions require not only special exit facilities but special assistance or supervision during an emergency. For example, minimum doorway and exit widths may be determined by the size of beds. Ramps may be necessary rather than stairways.

Particular attention must also be given to exits in assembly occupancies. The large numbers of people who normally gather in places of assembly are usually unfamiliar with the building layout and may tend to lose their sense of direction. The danger of panic in an emergency may become acute. It is therefore of utmost importance that the width and spacing of aisles, the arrangement of seats, the illumination of exit signs and exitways, door hardware design and many other egress-related details be completely and carefully regulated.

A theater is a good example of the distinctive characteristics of assembly occupancies. Scenery, properties, and projection equipment are the principal fire hazards. Audiences are in unfamiliar surroundings

and performances may be presented with extremely low illumination levels. These conditions emphasize the need for exit facilities that are designed with great care so that evacuation may be as rapid and orderly as possible.

It is acceptable for half of the exit stairways in business and residential occupancies to discharge into a lobby area at the ground level if the area is provided with automatic sprinkler protection.

Of necessity, small shops, stores and restaurants facing such a lobby are allowed doorways and display windows opening into the lobby even though, in a strict sense, they introduce a fire hazard into the building exit. Where such shops adjoin a lobby used as an exit, they should have a positive separation with dividing walls or partitions having a fire-resistance rating conforming to the requirements for the separation of mixed occupancies. Openings into the lobby from stores should be protected with self-closing fire doors and fire shutters unless the stores are individually protected by automatic sprinkler systems. The exits from rooms or other areas adjoining a lobby should comply with the applicable exit requirements of the code.

Exterior Exits

Exits need not be within the building walls. Exterior corridors and stairways are permissible and are widely used in motels and similar residential-type occupancies. On the other hand, the old-fashioned outside fire-escape is no longer acceptable. It is still permitted, but only when deficiencies in existing buildings cannot otherwise be corrected. Width and travel distance requirements for exterior corridors and stairs should be the same as those for interior exits. For most conditions, it is impractical to separate these corridors from the areas they serve with a fire-resistive wall. This makes it extremely important to have two or more well separated exitways.

Smokeproof Towers

One means of egress which can be effective and usable under nearly every adverse condition in high rise buildings is the smokeproof tower or fire tower. A smokeproof tower can be described as a stairway that is isolated from the rest of the building by continuous fire-resistive construction and so designed that smoke or products of combustion from a fire in the building cannot readily enter the tower. Communication between the building and the tower is through passageways or balconies that are open to the building exterior or to a special stairway enclosure.

In order to reach the enclosed stairway, it is necessary to pass through two fire doors; one from the building to the balcony or vestibule and the second from the balcony or vestibule to the stair tower. Such towers serve both as a smoke-free exitway for the occupants and as access to the upper floors to be used by fire fighters.

A smokeproof tower provides a safe means for persons to pass around an area involved in fire. It provides greater protection than the typical interior fire-resistive stairway enclosure; use of which can be made difficult, if not dangerous, by a single open fire door. This misuse has proven almost impossible to prevent.

Objections to smokeproof towers usually center on esthetic, economic or security factors. Architects find them a problem in design, building owners are not amenable to relegating valuable space to non-income producing use, and building security systems must control unauthorized entry.

BCMC has recommended that a smokeproof tower be required in all buildings over 75 feet (22.9 m) in height. Design details for smokeproof towers are included in the NFPA Life Safety Code.

Horizontal Exits

Most egress requirements in building codes attempt to provide safe, adequate, and clearly identified routes to the building exterior for all occupants. An exception, recognized by most codes, permits "horizontal exits" into a refuge area to be used as an alternate to exterior exits for up to half of the required exit capacity in most occupancies. A horizontal exit is defined as a passageway through or around a fire partition or fire wall that leads from an area involved in fire to a refuge area that will afford a safe retreat from the fire and smoke. This kind of arrangement is particularly important in institutional occupancies where persons are either incapable of or restrained from leaving the building. Horizontal exits are recognized in the Life Safety Code and in the model codes.

A horizontal exit may lie wholly within a building, or may be on the exterior such as an enclosed bridge between buildings, or a balcony around a fire wall. To qualify as an exit within a building, it must pass through a fire wall or partition with fire resistance sufficient to contain any fire in the given occupancy. Most building codes require not less than a 2-hour fire-resistive separation. Further, the opening for the horizontal exit must be of a limited size and be provided with a self-closing fire door with a minimum fire protection rating of 1½-hours on one side. Another approved fire door, or opening protec-

tive system, may be required on the other side in openings in walls having a fire resistance rating of more than 2 hours.

The horizontal exit must lead into an area of a size sufficient to hold the occupant load it is intended to serve. Common code practice requires a minimum of three square feet (0.3 m²) per person and 20 square feet (1.9 m²) for each bed that must be moved.

The use of horizontal exits necessitates exit facilities to the outside on either side of the fire wall or partition. While allowable travel distances will usually require such distribution of exits on either side of the fire barrier, their exact location may be affected by this limitation. In addition, horizontal exits may not be substituted for the entire prescribed exit capacity. At least fifty percent of the total required exit capacity for a building must be provided by other than horizontal exits.

Egress From Tall Buildings

As greater numbers of tall buildings for residential and business use are being built, concern over the problem of safety for upper-floor occupants has increased. It is, of course, impractical to expect all of the occupants on the upper stories to be able to leave the building via the stairways. Computations of evacuation time for various numbers of persons on a per floor and per stairway basis show that the time periods people would be required to wait are well beyond that which most could comfortably tolerate under normal conditions—let alone under the stress of an emergency.

Many people are physically incapable of walking down more than a few flights of stairs. Even from lower stories, the descent could be tiring for some, and even one or two slightly handicapped and slower-moving persons could dangerously impede the entire evacuation process. As a result, occupants of high rise buildings may be completely dependent on elevators to get from the upper floors and fire fighters may have to utilize them to reach the upper levels.

The model codes do not require elevators in buildings, although the New York City Building Code does require elevators for any building exceeding a height of four stories. As has been mentioned earlier, elevators are not recognized as a means of egress because of the ever present risk of power or control failure during an emergency.

The problem of evacuation of high rise buildings has been given extensive study over the past several years. This has led to the development of a special set of requirements in building codes for high rise residential and office buildings. It is worth noting here those particular

requirements relating to elevators and elevator controls which have been recommended by BCMC. First, except for the main entrance floor, elevators must open into elevator lobbies which are separated from the rest of the building by the same construction required for corridors. Second, elevator lobbies must be equipped with smoke detectors which, when activated, will result in the return of all cars to the main floor, or to another designated level in the event the main floor detector is activated. There have been several instances where automatic elevators have stopped at the fire floor, thus exposing the occupants to the full effects of the smoke and hot gases at that level. If a detector is activated, all cars are required to be put under manual control after they have reached the main floor. A third requirement for elevators in high rise buildings is that at least one car be large enough to accommodate a standard ambulance stretcher and medical attendants. (Minimum inside car platform of 4 feet 3 inches by 6 feet 8 inches) (1.3 m by 2.0 m.)

Another related requirement in the high rise recommendations is the provision which allows areas of refuge on each floor to be used as an alternate to automatic sprinkler protection throughout the building. All floor areas more than 15,000 square feet (1393.5 m²) are required to be divided into two or more protected areas of approximately equal size. The walls and doors between areas of refuge are to be as required for horizontal exits, i.e. 2-hour walls and 1½-hour doors.

The concept of refuge areas is hardly new. Even the earliest exit standards were based on the presumption that the exit could provide a tenable area during the egress period. In effect, all that has really been added is the assumption that prompt fire department response and the fire extinguishment capabilities will forestall the need for immediate evacuation from modern structures, and that the refuge areas, remaining safe from fire and smoke, can safeguard the occupants during the period of extinguishment.

Exit Details

Proper exit design necessitates the incorporation of many details: the width of stair treads and the height of risers; the number of steps between each landing; the height, positioning and distance from the wall of handrails; the use of winders; the slope of ramps; the door hardware and mounting-frame requirements; the surface-burning characteristics of interior finish used in exits; normal and emergency lighting requirements; and exit markings.

There are occupancies where the exit facilities must be designed to accommodate the physically handicapped. The Specifications for Making Buildings and Facilities Accessible to and Usable by Physically Handicapped People (ANSI A117.1—1980) contains provisions that are intended for use in buildings and facilities used by the public.

Fire protection of exit enclosures is governed by the same criteria that apply to any vertical opening in a building. As a general rule, building codes require a minimum of 2-hour fire-resistive construction for exit enclosures in buildings four or more stories high (the Uniform Building Code specifies five stories), and 1-hour fire-resistive construction in buildings under four stories. This enclosure not only helps to prevent fire spread, but also protects anyone in the exitway from the heat of a fire during the period of evacuation. The importance of this protection is discussed in Chapter 8.

Some consideration has been given to the possible effect heat radiating from doors—either to corridors or to stairways—will have on those using the exit. The primary concern is that anyone passing in front of a door might be subjected to excessive heat if the temperature on the unexposed surface of the door is not limited. This is a theoretical assumption only and there are no data to indicate that use of exits has been impaired where conventional fire doors have been used. It stands to reason that if the heat emanating from a door were to approach an intensity that could cause discomfort to persons passing that door, a more serious concern would be the likelihood of smoke infiltration.

Summary

Basic exit criteria have been derived empirically, growing out of observations of existing practices and by studying the rates at which people can move through corridors and down stairways. Exit capacity, or more precisely, the number of people able to pass through an exit of a given width within one minute, was also determined by studies.

Both stairways and some types of escalators can be used as exits. Elevators, on the other hand, should not be so used because of the possibility of power or control failure and the subsequent entrapment of passengers.

Building exits should be remote from one another to reduce the possibility of more than one exit being blocked by fire or smoke.

Good exit design requires the incorporation of many details that are related to dimensions and to the arrangement of various elements.

Complete occupant evacuation or egress may be impractical in

high-rise structures. Alternate provisions to conventional exit methods may therefore be needed. Refuge areas at various levels in a tall building providing the same degree of fire safety as the exit can be a more realistic approach to occupant safety than exits leading to outside areas.

References

AMERICAN NATIONAL STANDARDS INSTITUTE, *Specifications for Making Buildings and Facilities Accessible to, and Usable by, the Physically Handicapped*, ANSI A117, New York, N.Y. 1980

COUNCIL OF AMERICAN BUILDING OFFICIALS, Board for the Coordination of the Model Codes, *Report on Means of Egress*, April 1976.

FRUIN, J. J., *Pedestrian-Planning and Design*, Metropolitan Association of Urban Designers and Environmental Planners, Inc., New York, N.Y. 1971.

GALBREATH, M., "Time of Evacuation by Stairs in High Buildings," *Fire Fighting in Canada*, Feb. 1969. (1980 SFPE Paper).

GENERAL SERVICES ADMINISTRATION, *Public Buildings Service International Conference on Fire Safety in High-Rise Buildings*, Warrenton, Virginia, May 1971.

HEBERT, R.V., "Fire Safety in High Buildings," *Proceedings at Atlantic Provinces Chapter of the Specification Writers Association*, March 1970.

NATIONAL RESEARCH COUNCIL OF CANADA, ASSOCIATE COMMITTEE ON THE NATIONAL BUILDING CODE, *Measures for Fire Safety in High Buildings* (NRCC No. 13366), Ottawa, Canada, 1973.

PAULS, T.L., "Fire Safety and Related Man-Environment Studies," National Research Council of Canada, Division of Building Research NRCC 10055, November, 1975.

STEVENS, R.E., "Smokeproof Towers," *Fire Journal*, Vol. 60, No. 1, January 1960, pp. 54-55.

NATIONAL BUREAU OF STANDARDS, "Design and Construction of Building Exits," *NBS Miscellaneous Publication M151*, Washington, D.C., Oct. 10, 1935.

VOLKAMER, C.W., "Fire Department Operations in High-Rise Buildings," *The Building Official*, Building Officials and Code Administrators International, Vol. 4, No. 6, June 1970, pp. 11-13, 26.

CLASSIFICATION OF BUILDINGS BY TYPES OF CONSTRUCTION

A well-established means of codifying fire protection and fire-safety requirements for buildings is to classify them by types of construction according to the materials used for the structural elements and the degree of fire resistance each affords.

In early codes, only two classifications of construction were identified: “fireproof” and “non-fireproof”. The term “fireproof” was replaced by the term “fire-resistive” as it was recognized that no material or building is totally fireproof. It is possible, however, to design buildings to resist a fire without serious structural damage. Optimum fire-resistive design balanced against anticipated fire severity is the objective of fire-protection requirements in modern codes.

Several distinct types of construction which use combustible framing were originally classified based on the materials used in the exterior wall construction—masonry or wood—and the type and size of the framing members i.e., heavy timber versus conventional framing. As fire-resistance ratings for construction assemblies were recognized in building codes, subclassifications of building types were added for both noncombustible and combustible types of construction based upon the degree of fire resistance provided.

Code regulations governing the size of buildings, area and height, and their allowable uses are usually predicated on the relative fire load represented by the occupancy and the construction materials used in the building.

Construction Classifications in the Model Codes

The construction types presently identified in the model codes range in number from seven in the 1976 National Building Code to ten in the 1981 Basic Building Code. All of the classifications, however, are derived from five fundamental construction types: Fire-Resistive,

Noncombustible, Exterior-Protected Ordinary, Heavy Timber, and Wood Frame. These descriptive names are now being discontinued because they no longer define the construction types as precisely as needed. However, the names are helpful in tracing the development of building types.

Although the Fire-Resistive construction types differ in detail from code to code, the four model codes all define sub-types of Fire-Resistive construction using as a basis the amount of fire protection required for the structural members (2, 3, or 4 hours).

Where the interior structural members and floors are of noncombustible materials with fire-resistance ratings of one hour or less, the type of construction is generally identified as Noncombustible. Most codes sub-divide the Noncombustible classification into protected and unprotected types.

The model codes employ three broad classifications for combustible types of construction: Exterior-Protected Ordinary, Heavy Timber, and Wood Frame. Exterior-Protected Ordinary and Wood Frame types each include two sub-types: protected and unprotected. In most respects, they are almost identical except for their exterior wall requirements. Heavy Timber construction is unique because it is identified by detailed requirements mainly relating to the size of structural members and their connections. Properties such as combustibility or fire resistance are not specifically included in the requirements for Heavy Timber construction with the exception that exterior walls are required to be of noncombustible construction.

Construction type classification in building codes is more of a convenience than a necessity. The National Building Code of Canada does not classify buildings in the traditional manner as is done in U.S. codes, but rather specifies fire-resistive requirements for the structural components of a building depending on its occupancy and its story height and floor area. In this code two basic types of construction are recognized: combustible and noncombustible construction. These are further subdivided by the characteristics of the materials used in construction under fire conditions, as shown in Table 13.

The National Building Code of Canada establishes the areas for the sub-types of construction identified in the table by placing them into three groups which are based upon fire-safety characteristics, combustibility or noncombustibility, and stability or instability under fire conditions. These groups are:

Group I—construction limited to the smallest of buildings.

**Table 13—Types of Construction And Their Fire Safety Characteristics
National Building Code of Canada***

Basic Type of Construction	Group	Sub-Types	Characteristics (under fire load conditions)
Combustible Construction	I	Wood frame	Fuel contributing and unstable
		Wood post and beam	
		Plank	
Plastic	Other unprotected combustible		
Other unprotected combustible			
Noncombustible Construction	II	Heavy timber construction and other protected combustible construction	Fuel contributing but partially stable to the degree of fire resistance
		Unprotected steel construction	Non-fuel contributing but unstable
		Ordinary prestressed concrete	
Thin unprotected reinforced masonry	Other unprotected noncombustible construction		
Other unprotected noncombustible construction			
Noncombustible Construction	III	Steel construction with fire resistance	Non-fuel contributing and stable to the degree of fire resistance
		Masonry with fire resistance	
		Reinforced concrete with fire resistance	

*Table reproduced from "Steel and Fire Safety as required in the National Building Code of Canada—1975," R. V. Hebert, Canadian Steel Industries Construction Council.

Group II—construction limited to small and intermediate buildings (with some variations in treatment).

Group III—construction may be used for all buildings, and is mandatory for the largest and highest buildings, and for some smaller buildings with hazardous occupancies.

It is interesting to note that wherever $\frac{3}{4}$ -hour protected combustible construction is required by the National Building Code of Canada, unprotected noncombustible construction may be substituted.

The New York City Building Code divides construction types into two groups, noncombustible and combustible; each of these in turn is divided into five types. These subdivisions are distinguished by the fire resistance required for the interior structural members and for the exterior walls.

Model Codes Standardization Council Classifications

In order to achieve better uniformity in building code requirements, the Model Codes Standardization Council (MCSC) established a committee in 1972 to study the classifications and fire-resistance requirements for types of construction used in the model building codes and to develop recommendations for the model code organizations.

The MCSC concluded that in order to rationally compare the various types of construction, a notational system was needed to identify the fire resistance required for three basic elements of the building. These elements are the exterior wall, the primary structural frame, and the floor construction. A three-digit notation was developed as follows:

First Digit— Hourly requirement for exterior bearing wall fronting on a street lot line.

Second Digit— Hourly requirement for structural frame or columns and girders supporting loads from more than one floor.

Third Digit— Hourly requirement for floor construction.

Thus a (332) building would have 3-hour exterior bearing walls (if used), a 3-hour structural frame and 2-hour floor construction and would correspond to the Basic Building Code Type IB building, the Uniform Building Code Type I Fire Resistive building, the Standard Building Code Type II building and the National Building Code (AlnsA) Fire Resistive Type B building. For Heavy Timber construction the notation "H" was used for the structural frame and floor construction designations.

Using the MCSC notational system, a comparison of types of construction in the model building codes was made, as shown in Table 14.

**Table 14—Classification of Buildings by Type of Construction
Comparison of Model Building Codes Using MCSC Notation System**

Basic Building Code 1981 Edition	Uniform Building Code 1979 Edition	Standard Building Code 1979 Edition	National Building Code (AInsA) 1976 Edition
Type 1A (433)		Type I (443)	Fire Resistive A (443)
Type 1B (332)	Type I F.R. (432)	Type II (332)	Fire Resistive B (332)
Type 2A (221½)	Type II F.R. (422)		
Type 2B (111)	Type II 1 Hr. (111)	Type IV 1 hr. (111)	Protected Ltd.-Comb. (211)
Type 2C (000)	Type II N (000)	Type IV Unprot. (000)	Unprot. Ltd.-Comb. (000)
Type 3B (211)	Type III 1 hr. (411)	Type V 1 hr. (111)	
Type 3C (200)	Type III N (400)	Type V Unprot. (100)	Ordinary (200)
Type 3A (2HH)	Type IV H.T. (4HH)	Type III (1HH)	Heavy Timber (2HH)
Type 4A (111)	Type V 1 hr. (111)	Type VI 1 hr. (111)	
Type 4B (000)	Type V N (000)	Type VI Unprot. (000)	Wood Frame (000)

Note: The types of construction shown for each model code represent the best fit with the MCSC classifications.

F.R.—Fire Resistive

H.T.—Heavy Timber

As a result of its comparative study, the MCSC proposed that the basic types of construction, now recognized in the codes, be continued but that they be reordered to some degree and be divided into two groups: "Noncombustible" and "Combustible". It was also proposed that the identifying names for types of construction, such as "fireproof", "ordinary", "heavy timber", etc., be dropped because current design methods and architecture no longer follow the concepts in vogue when the named building types were established. The classifications proposed by the MCSC are shown in Table 15.

It should be understood MCSC did not propose that all of the types of construction in its tabulation were needed for code purposes. Instead, it recommended a method to identify types of construction in codes through use of numerical notations indicating the fire resistance of the walls, structural frame and floors.

The Model Codes Standardization Council also developed standard nomenclature for identifying and defining the structural elements in buildings as they relate to fire resistance. For example, it was found in reviewing various codes and fire protection standards that floor construction was referred to by such terms as "floors", "floor assemblies", "floor and ceiling assemblies", and "floor deck construction." If codes agree, for example, that "floor construction" includes the floor deck and all beams, joists, and other structural elements directly supporting

**Table 15—Model Codes Standardization Council
Recommended Types of Construction**

Noncombustible		
Type 1 (433)	Type II (222)	
Type 1 (332)	Type II (111)	
	Type II (000)	
Combustible		
Type III (211)	Type IV (2HH)	Type V (111)
Type III (200)		Type V (000)

the loads from the floor, as recommended by MCSC, then some misinterpretation of a code's intent would be avoided.

Classifications of Building Types

Following the completion of the MCSC recommendations in 1974, the model code organizations adopted a number of changes to their requirements for types of construction to agree with the MCSC classifications. These are now reflected in their most recent code editions. However, it was recognized that some conflicts between the model codes still remained. In 1975, therefore, the Board for the Coordination of the Model Codes (BCMC) of the Council of American Building Officials (CABO) established a committee to develop more detailed recommendations for types of construction.

The Committee's work was completed in 1980 and its recommended definitions of types of construction and fire resistance requirements finalized. The proposed requirements for fire resistance of structural elements resulting from the BCMC Committee study are shown in Table 16.

Five basic types of construction are proposed. Two are identified as noncombustible construction and three as combustible construction types.

The same type of notational system developed by MCSC is used by BCMC to identify the fire resistance of the exterior walls, the structural frame, and the floor construction, except the first digit number assigned represents the hourly rating requirement for exterior bearing walls facing on an *interior* lot line rather than the *street* lot line.

In Table 16 the fire resistance requirements for the structural frame, interior bearing walls, floor construction and roof construction are shown. Requirements for exterior walls are discussed in Chapter 9.

The term "structural frame" as used in the table refers to the columns and the girders, beams, trusses, and spandrels having direct connections to the columns and all other members which are essential to the stability of the building as a whole. The members of floor or roof panels which have no connection to the columns are considered part of the floor or roof construction and not classified as a part of the structural frame.

Type I Construction (Fire-Resistive)—Type I Construction (Fire-Resistive) is construction in which the structural members are noncombustible and are fire protected as specified in Table 16. This classification is divided into two subtypes, Type I (332) and Type I (222), the basic

Table 16—Fire Resistance Requirements For Structural Elements (Hrs.)

Structural Element ^a	Type of Construction								
	Noncombustible Materials ^{e,g}				Combustible Materials				
	Type I	Type II	Type III	Type IV	Type V	Type III	Type IV	Type V	
	332*	222*	111* ^d	100*	211* ^d	200*	2HH*	111* ^d	100*
Structural Frame Including Columns, Girders, Trusses	3 ^b	2 ^b	1	0	1	0	HT	1	0
Bearing Walls Interior	3 ^b	2 ^b	1	0	1	0	1/HT	1	0
Floor Construction Including Supporting Beams and Joists	2	2	1	0	1	0	HT	1	0
Roof Construction Including Supporting Beams and Joists	1½ ^c	1 ^{c,f}	1 ^{c,f}	0 ^{c,f}	1 ^c	0	HT	1 ^c	0

*KEY: 1st Digit = Hourly rating of exterior bearing wall on an interior lot line
 2nd Digit = Hourly rating of structural frame
 3rd Digit = Hourly rating of floor construction.

a) **Structural Frame**—The structural frame shall be considered to be the columns and the girders, beams, trusses, and spandrels having direct connections to the columns and all other members which are essential to the stability of the building as a whole. The members of floor or roof panels which have no connection to the columns shall be considered secondary members and not a part of the structural frame.

b) **Roof supports**—Fire resistance of structural frame and bearing walls may be reduced by one hour when supporting a roof only.

c) **Roof Construction** 20 feet (6 m) or higher: Except in Hazardous (H), Mercantile (M), Moderate Hazard Factory-Industrial (FI) and Moderate Hazard Storage (SI) occupancies, fire protection of roof construction may be omitted where every part of the roof construction and structural frame is twenty (20) feet (6 m) or more above the floor immediately below. Heavy timber roof construction may be used where unprotected roof construction is permitted in one story buildings. Fire retardant treated wood roof construction may be used for unprotected roof construction in one (1) and two (2) story buildings.

- d) When one-hour fire resistance rated construction throughout is required, an approved automatic sprinkler system may be substituted provided such system is not otherwise required. Such substitution shall not waive separation requirements for shaft enclosures, corridors, stair enclosures, exit passage-ways, and exterior wall protection due to proximity of property lines.
- e) Fire protection may be omitted from the bottom flange of lintels, shelf angles and plates spanning not more than 6 feet (2 m) whether a part of the structural frame or not, and from the bottom flange of lintels, shelf angles and plates not a part of the structural frame, regardless of span.
- f) Fire retardant treated wood may be used provided the assembly attains the required fire resistance ratings.
- g) Combustible materials are permitted in buildings of Types I and II Construction and are not treated in this report. Refer to the model codes.

difference being in the level of fire protection specified for the structural frame.

For both sub-types, the required fire resistance of those portions of the structural frame and bearing walls supporting roof loads only may be reduced by one hour.

The fire protection requirements for Type I (332) Construction and Type I (222) Construction were selected because they provide reasonable fire safety for the structure for occupancies with moderate and low combustible contents. In occupancies with higher fire loads and hazardous uses, fire protection is supplemented by additional protection, usually including an automatic fire extinguishing system. Even in occupancies with moderate fire loads such as in mercantile and in some factory-industrial and storage uses, supplementary fire safety precautions are required. These include restrictions on the building size or requirements for automatic fire extinguishing equipment.

In Type I Construction, only noncombustible materials are permitted for the structural elements of the building. This is an accepted regulation that appears in practically every modern building code. Obviously, if combustible structural materials were allowed in noncombustible building types, the whole concept of their allowable use (height and area) would become meaningless. However, for practical reasons, the use of some combustible materials in Type I and Type II buildings are permitted for other than structural components. Roof coverings, some types of insulating materials, and limited amounts of wood for interior finish and flooring have been traditionally recognized as not adding significantly to the fire hazard or fire load if these materials are properly regulated and qualified by tests.

Some codes have attempted to regulate combustible materials by using a definition of noncombustible materials which includes two or three alternates that allow for the acceptance of materials having relatively low surface burning characteristics. The purpose of this definition was to recognize certain assemblies containing limited amounts of combustibles and nonhomogenous components such as gypsum wallboard which, although covered with paper, is used as a fire resisting material. These alternate definitions use the criterion of a flame-spread rating as determined by the Standard Method of Test for Surface Burning Characteristics of Building Materials, ASTM E 84. That test measures the rate of visible flame travel over the surface of the material in the testing assembly, but does not furnish data needed for measuring "combustibility." Employing these alternates in the defini-

tion encourages the use of combustible materials in situations where noncombustibility is critical.

Rather than twist the definition for the accommodation of certain materials, a more fundamental approach is to define limited uses and combustibility characteristics of materials that may be acceptable in buildings of noncombustible construction. This approach is followed in the National Building Code of Canada and by the BCMC Committee in its recommendations for the allowable kinds and extent of use of combustible material in noncombustible buildings.

Type II Construction (Noncombustible)—Type II Construction (Noncombustible) is a construction type in which the structural elements are entirely of noncombustible materials and either protected to have some degree of fire resistance, usually one-hour, Type II (111), or completely unprotected except for exterior walls, Type II (100) Construction.

The fire protection required in Type II (111) Construction will afford more than adequate fire safety for residential, educational, institutional, business, and assembly occupancies without supplementary restrictions. Height limits, however, are commonly prescribed for this type of construction. When used for other occupancies involving a greater fire loading, additional fire safety precautions are usually required, such as more stringent area limitations and automatic fire extinguishing equipment. In occupancies with low combustible contents, the absence of fuel in noncombustible construction not only helps prevent the spread of fire but also reduces potential risk of a fire starting within the structure itself.

The noncombustible feature is valuable because it prevents fire from spreading through concealed spaces or involving the structure itself. Because of this attribute, a fire in a building of noncombustible construction can be controlled more readily.

Modern steel buildings that are classified as Type II (100) have a far greater range of applications than the early sheet-steel buildings which were used almost exclusively for industrial occupancies. The steel building of today can have many architectural amenities: panelled walls, insulation for greater energy efficiency, and attractive exterior and interior finishes. Economical, noncombustible, steel construction is adaptable for commercial uses such as sales rooms, stores, banks, industrial plants, office buildings, research laboratories and schools.

Type III Construction (Exterior Protected Combustible)—Type III Construction (Exterior Protected Combustible) is a construction type in

which all or part of the interior structural elements may be of combustible materials or any other material permitted by the code. The exterior walls are required to be of noncombustible materials and have a degree of fire resistance depending on the horizontal separation and the fire load. Type III Construction is further divided into protected and unprotected sub-types. Protected construction, Type III (211), has 1-hour protection for the floors and structural elements. Type III (200) Construction has no protection for the floors or structural elements. Whether fire protection is provided or not, it is essential that all concealed spaces be properly fire stopped in buildings of combustible construction. This must be done with care in all furred spaces, partitions, ceilings spaces and attics. Codes are very specific as to the materials to be used for fire stopping and the locations where fire stopping is required. To be effective, fire stopping must completely close off and subdivide the combustible construction into limited areas thereby restricting the spread of fire and hot gases and allowing additional time for detection and evacuation of the building or area involved.

The 1-hour fire protection provided in Type III (211) Construction offers a measure of safety for fire fighting and evacuation before the construction itself becomes involved. It has been well established, however, that combustible parts of any fire rated assembly will be burning actively before the end of the rated time period. For this reason, that portion of the fire load represented by combustible structure must be considered as part of the total potential fire load, whether or not the construction is protected.

Type IV Construction (Heavy Timber)—Type IV Construction (Heavy Timber) is a construction type in which the structural members are of unprotected wood with a larger cross-sectional area than structural design considerations alone might require. No concealed spaces are permitted in the floors, roof or other structural members. During a fire, heavy timber construction resists failure longer than a conventional wood frame structure simply because the structural members are larger, with a smaller surface to volume ratio, and take longer to burn.

Heavy timber construction, or “mill construction”, is not just a construction type using large-size framing members but is more properly considered as a building system. It was developed during the mid-1800’s by insurance interests for the purpose of reducing fire losses in the many textile factories, paper mills, and storage buildings

in the New England states. Through the intelligent use of combustible materials of sufficient mass, the absence of concealed spaces, and by giving attention to details to avoid sharp corners and ignitable projections, the chance of rapid spread of fire are lessened and the probability of serious structural damage is reduced.

The minimum sizes for structural members needed to qualify for heavy timber construction are the same in most modern building codes. The nominal dimensional requirements recommended by the BCMC Committee are shown in Table 17.

Table 17—Recommended Nominal Dimensional Requirements For BCMC Type IV (2HH) Construction

	Supporting Floors	Supporting Roofs
Columns	8" x 8"	6" x 8"
Beams and Girders	6" x 10"	4" x 6"
Arches	8" x 8"	6" x 8", 6" x 6", 4" x 6"
Trusses	8" x 8"	4" x 6"
Floors	3" T & G or 4" on edge w/1" flooring	
Roofs	2" T & G or 3" on edge or 1½" plywood	

Specific details for framing are included in the actual code descriptions for heavy timber construction.

To emphasize how important construction details and proper application of the principle of heavy timber construction are, Edward Atkinson, one of the early developers of mill building design, issued the following commentary entitled "What Mill Construction is Not":

1. Mill construction does not consist in disposing a given quantity of materials so that the whole interior of a building becomes a series of wooden cells; being pervaded with concealed spaces, either directly connected each with the other or by cracks through which fire may freely pass where it cannot be reached by water.
2. It does not consist in an open-timber construction of floors and roof resembling mill construction, but which is of light and insufficient size in timbers and thin planks, without fire stops or fire guards from floor to floor.

3. It does not consist in connecting floor with floor by combustible wooden stairways encased in wood less than two inches thick.
4. It does not consist in putting in very numerous divisions or partitions of light wood.
5. It does not consist in sheathing brick walls with wood, especially when the wood is set off from the wall by furring, even if there are stops behind the furring.
6. It does not consist in permitting the use of varnish upon woodwork over which a fire will pass rapidly.
7. It does not consist in leaving windows exposed to adjacent buildings unguarded by fire-shutters or wired glass.
8. It is dangerous to paint, varnish, fill, or encase heavy timbers and thick plank as they are customarily delivered, lest what is called dry rot should be caused for lack of ventilation or opportunity to season.
9. It does not consist in leaving even the best-constructed building in which dangerous occupations are followed without automatic sprinklers, and without a complete and adequate equipment of pumps, pipes, and hydrants.
10. It does not consist in using any more wood in finishing the building after the floors and roof are laid than is absolutely necessary, there being now many safe methods available at low cost for finishing walls and constructing partitions with slow-burning or incombustible material."

These precautions, issued almost 100 years ago, are as valid today as then if the assumed level of safety of this type of construction is to be realized.

The degree of fire resistance actually afforded in buildings of heavy timber construction cannot readily be evaluated by standard ASTM fire tests. For example, in tests conducted at The Ohio State University in 1968, a standard 3-inch (76-mm) plank floor with 1-inch (25-mm) finish flooring failed after approximately ½-hour exposure to the standard fire test. During the tests it was found that the quantity of smoke driven off from the unexposed floor surface raised serious questions as to whether this type of construction is effective as a barrier to the spread of smoke when the construction itself appears to be the source. Further, the heavy timber material contributed so much fuel in the fire test that the gas supply, used in the furnace as a heat source, had to be shut off. Otherwise, the temperatures would have become excessive and the test considered nonstandard. Other tests performed by the National Bureau of Standards (1945) indicate that it would require a well-laid 6-inch (152-mm) laminated floor with a 1-inch (25-mm) tongue-and-groove top floor to develop a 1-hour fire-resistance rating.

A number of fire-resistance tests on glued laminated timbers have been conducted in Europe. Data from these tests show that glue-laminated timber used as beams must have minimum dimensions of

5½ by 16½ inches to achieve a 1-hour fire-resistance rating. In order to obtain a 1-hour fire-resistance rating, a fully loaded timber column nearly 12 by 12 inches in cross-section is needed. These dimensions are considerably greater than the minimum dimensions prescribed in the model building codes. Such disparity suggests that if a fire resistance rating were assigned to heavy timber construction as now defined, it would be less than one-hour.

Type V Construction (Wood Frame)—Type V Construction (wood frame) is a type of construction in which the structural members are entirely of wood or any other material permitted by the code. Depending on the exterior horizontal separation, the exterior walls may or may not be required to be fire resistant.

Type V Construction is probably more vulnerable to fire, both internally and externally, than any other building type. Accordingly, it is essential that greater attention be given to the details of construction of this basically light wood frame building. Fire stopping in exterior and interior walls at ceiling and floor levels, in furred spaces, and other concealed spaces can serve to retard the spread of fire and hot gases in these vulnerable areas.

Type V Construction is subdivided into two subtypes: Type V (111) Construction, which has 1-hour protection throughout, including the exterior walls, and Type V (100) Construction, which has no fire protection or fire resistance requirements, except for the exterior walls when horizontal separation is less than 10 feet (3 m).

Mixed Types of Construction

Where two or more types of construction are used in the same building, it is generally recognized that the requirements for occupancy or height and area for the least fire resistive type of construction, would apply. However, in cases where each building type is separated by adequate fire walls or area separation walls having appropriate fire resistance, each portion may be considered a separate building.

Another general limitation included in some codes prohibits construction types of lesser fire resistance to support construction types having higher required fire resistance. In the event of a fire, the risks of a major structural collapse are generally too great to permit this type of design. This limitation does not necessarily apply where construction supports nonbearing separating partitions which provide protection for exit corridors or tenant spaces.

Summary

Building codes classify buildings into types of construction — combustible and noncombustible— according to the materials used for their structural elements. To obtain a reasonable degree of fire safety in large-size buildings, types of construction are required to have various degrees of fire resistance. The characteristics of combustible construction types warrant considerable attention to the details of construction in order to prevent spread of fire through concealed spaces and over combustible surfaces.

References

AMERICAN SOCIETY FOR TESTING AND MATERIALS—*Standard Test of Materials in a Vertical Tube Furnace at 750 C* (ASTM E136-79), Philadelphia, 1979.

—*Standard Test Method for Surface Burning Characteristics of Building Materials* (ASTM E84-80), Philadelphia, 1980.

BLETZACKER, R.W., LANE, W.W., AND DENNING, D.W., *Fire-Resistance of Construction Assemblies (EES-245)*, Engineering Experiment Station, The Ohio State University, Columbus, OH, December, 1969.

MINISTRY OF TECHNOLOGY AND FIRE OFFICERS' COMMITTEE, JOINT FIRE RESEARCH ORGANIZATION, *Fire and Structural Use of Timber in Buildings*, Symposium No. 3, London, Oct. 25, 1967.

NATIONAL BUREAU OF STANDARDS, "Fire-Resistance of Heavy Timber Construction," *Technical News Bulletin No. 349*, May 1946.

NATIONAL BUREAU OF STANDARDS, *Fire Resistance Classifications of Building Construction (BMS 92)*, Washington, D.C., 1942.

SIEGEL, L. G., "The Severity of Fires in Steel Frame Buildings," *AISC Engineering Journal*, Vol. 4, No. 4, Oct. 1967, pp. 137-142.

U.S. DEPARTMENT OF COMMERCE, BUREAU OF STANDARDS, *Recommended Minimum Requirements for Fire-Resistance in Buildings, Building and Housing, No. 14*, Washington, D.C., 1931.

FIRE ENDURANCE OF BUILDING CONSTRUCTION AND MATERIALS

All modern building codes contain fire endurance requirements for walls, partitions, beams, columns, floor and roof assemblies. These requirements are based upon tests conducted in accordance with the "Standard Methods of Fire Tests of Building Construction and Materials," ASTM Designation E 119. The origin and development of this standard fire test procedure is discussed in Chapter 3.

With respect to construction assemblies, fire resistance is defined as the ability of an assembly to confine a fire to a given area or to continue to perform structurally when exposed to fire, or both. Fire endurance is the time period during which an assembly continues to perform these functions when exposed to fire. Thus, fire endurance requirements based upon ASTM E 119 are expressed in terms of hours or fractions thereof. Although technically the terms "fire resistance" and "fire endurance" have different meanings, they are frequently used interchangeably in building codes.

The standard fire test was developed primarily for the purpose of establishing a method for comparing the relative performance of different construction assemblies when exposed to a controlled laboratory fire. The results of tests conducted in accordance with this standard do not necessarily indicate how these assemblies will perform under actual fire conditions, which generally differ from the exposure specified in the standard. In addition, the test method has certain deficiencies in evaluating the comparative performance of different assemblies on an equivalent basis. Nevertheless, performance-oriented fire endurance requirements in contemporary building codes are based upon ASTM E 119.

The standard specifies, to varying degrees, the conditions of fire exposure, size of test assemblies, methods of recording data and acceptance criteria. Not included are specific requirements for the design and construction of test furnaces. Today, relatively few laboratories are

equipped to conduct standard fire tests. In North America, the most widely used facilities are operated by the Underwriters Laboratories Inc., the University of California, The Ohio State University, Underwriters Laboratories of Canada and the National Research Council of Canada. Other fire test facilities are operated by private companies for research and development purposes.

Over the years, literally thousands of different construction assemblies have been tested and qualified for fire endurance classifications ranging from thirty minutes to over four hours. Compilations and summaries of fire-resistant assemblies are published by many organizations. The most widely used listing in the United States is the Fire Resistance Directory, published annually by Underwriters Laboratories. Additional sources of information are the Factory Mutual Research Corporation, the American Insurance Association, and various trade associations such as American Iron and Steel Institute and the Gypsum Association.

The Standard Fire Test

During standard fire tests, a ‘‘representative’’ sample of a construction assembly is exposed to a controlled laboratory fire defined by the standard time-temperature curve, (Figure 2, Chapter 3). This curve specifies the average furnace temperature as recorded by thermocouples located in the immediate vicinity of the test assembly. The curve rises rapidly during the initial phases of the test—1000F (538C) at 5 minutes and 1550F (843C) at 30 minutes—and then increases more gradually to 2000F (1093C) at 4 hours. Tests are conducted in specially constructed furnaces usually with natural gas as a fuel. A typical furnace for testing floor and roof assemblies is shown in Figure 13.

The test method specifies a minimum size for each type of assembly. Walls and partitions must be at least 100 square feet (9.2 m²) in area and not less than 9 feet (2.7 m) in height or width. Floor and roof assemblies are at least 180 square feet (16.7 m²) in area with neither major dimension less than 12 feet (3.7 m). Columns must be at least 9 feet (2.7 m) in length, and beams 12 feet (3.7 m).

The fire endurance of an assembly is the time, after the beginning of the test, when any of several endpoint criteria are exceeded. In general, the endpoint criteria are defined to evaluate the assembly’s ability to continue to support any superimposed loads and to resist the passage of flame or hot gases or the buildup of excessive temperatures on the unexposed surface.

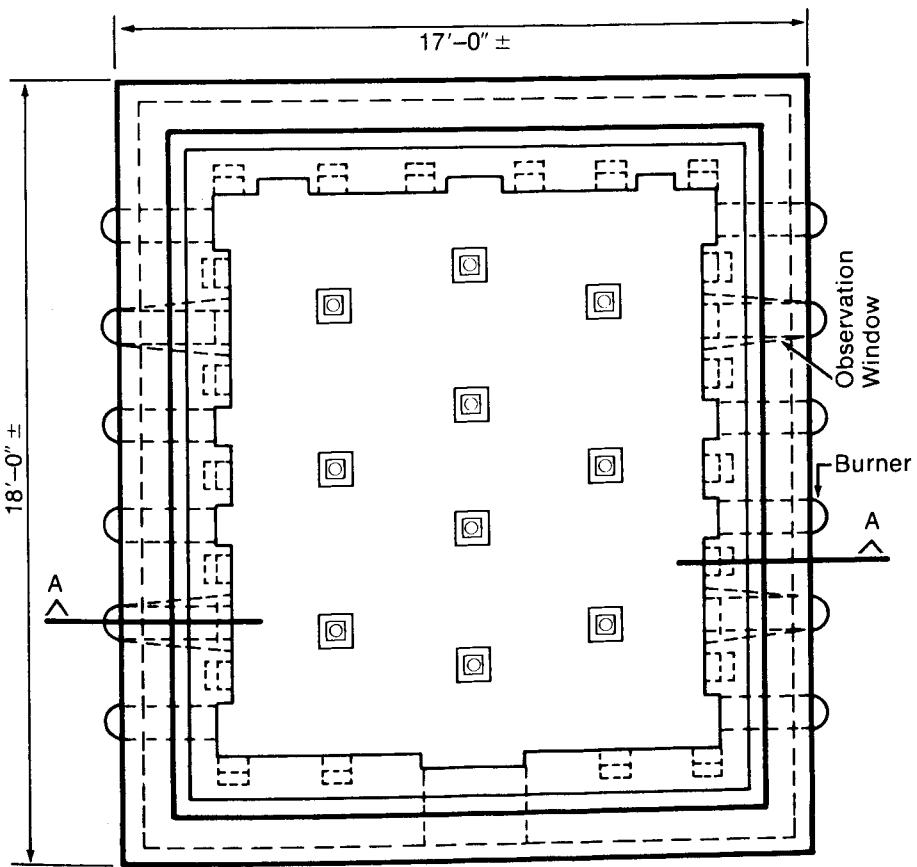

Plan View

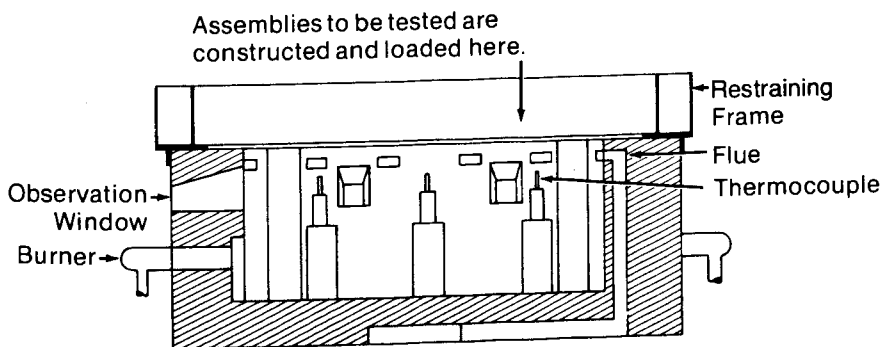

Section A-A

Figure 13. Plan and section of a typical furnace for conducting standard fire tests, which is used for determining ratings of floor and ceiling assemblies.

During wall, partition, floor, and roof tests, the temperature of the unexposed surface of the assembly is recorded by a series of thermocouples placed under 6 inch by 6 inch (152.4 mm by 152.4 mm) asbestos pads. The average temperature must not rise more than 250F (139C) above the initial room temperature. An increase of 30 percent in the temperature rise (75F or 42C) is permitted at individual thermocouple locations. The unexposed surface temperature limits are intended to define a lower bound for the ignition temperature of ordinary combustible materials.

In addition to temperature limits, the passage of flames or hot gases sufficient to ignite cotton waste is not permitted. The cotton waste endpoint does not generally come into play and is primarily a safeguard against the possibility of openings developing through the assembly or the buildup of excessive temperatures on the unexposed surface at locations which are not being monitored by thermocouples.

In general, columns, floor and roof assemblies, and loadbearing walls and partitions, are required to be tested under load. The test method does, however, include special provisions for testing structural steel columns, beams, and girders without load. The endpoint criteria for such tests are based upon temperature limits for the structural members which reflect the elevated temperature properties of steel and are intended to conservatively define the temperatures above which steel members would no longer be expected to continue to support their full design load.

Normally, the applied load is calculated so as to develop, as nearly as possible, design allowable stresses in the structural members as determined in accordance with nationally recognized structural design procedures. The acceptance criteria for loaded assemblies require the assembly to sustain the load "for a period equal to that for which classification is desired." In other words, structural failure is one of the specified endpoint criteria.

A recent change to ASTM E 119 permits the testing of loadbearing assemblies with less than the full design load. This change was instituted in recognition of the fact that construction assemblies are not subjected to full design allowable loads in many common building designs. In addition, a reduction in the applied load can significantly increase the fire endurance of many assemblies. As a result, in the application of these "limited load" tests it is important that the loading conditions assumed in building design are consistent with the test loads. **Scope**—In order to fully understand and properly apply the results of

ASTM E 119 fire tests, it is important to recognize conditions and limitations of the test method. As pointed out in Chapter 3, the standard time-temperature curve is intended to characterize temperatures reached in a fully developed compartment fire. It does not simulate the conditions represented by flames emerging from windows or other openings in an exterior wall, or from adjacent buildings. The ASTM E 119 exposure is, therefore, not intended to be applicable to columns and other structural members located outside of the exterior walls of a building. The requirements of the test method and the acceptance criteria clearly imply that the intent is to evaluate the performance of assemblies which are either located within a fire compartment or form the boundaries of a fire compartment.

Wall and partition assemblies, regardless of whether or not they are loadbearing, are tested with only one side exposed to the fire. Thus, the test assesses the ability of these assemblies to act as barriers against the spread of fire within a building. In the case of nonloadbearing walls and partitions, this is the typical application of fire endurance requirements in building codes. For loadbearing walls, however, an entirely different circumstance can arise. In certain applications, walls are required to be of fire-resistive construction because they are loadbearing and not because they are intended to perform a fire separation function. In such cases, the code may permit unprotected openings in the wall and a fire may spread through such openings and thereby subject the wall to exposure from both sides. This is not, however, a condition evaluated by the standard fire test.

The application of ASTM E 119 to exterior walls also deserves special comment. The cross-section of many exterior walls is unsymmetrical and the fire endurance of such assemblies can vary significantly depending upon which side of the wall is exposed to the fire. Therefore, since the standard time-temperature curve is not representative of exterior exposure fires, building code requirements for the fire endurance of exterior walls generally stipulate that the interior face of the wall be exposed to the fire during test. A more detailed discussion of the fire protection requirements for exterior walls is given in Chapter 9.

Floor and roof assemblies are tested with the fire exposure below the assembly. The ability of floor and roof construction to resist the spread of fire to spaces below the assembly is not evaluated by ASTM E 119. For floor assemblies, the philosophy inherent in the standard fire test is that exposure to a fire from beneath the floor represents the worst case condition. Because firespread is largely a convective and radiant

phenomenon, fires tend to spread upward. There have, however, been a few instances where fires have spread to lower floors through joints or other inadequately protected openings in the floor assembly. In the case of roof assemblies, resistance to external exposure is an important consideration and is evaluated by different test procedures. (ASTM E 108, Standard Methods of Fire Tests of Roof Coverings).

It is also important to recognize that the standard fire test only assesses the endurance of assemblies during the period of fire exposure. No attempt is made to evaluate the damage to an assembly or its suitability for use after fire exposure. The test method does not evaluate the combustibility of an assembly or the quantity or nature of smoke, toxic gases, and other products of combustion generated by the assembly. No evaluation is made of the flame-spread characteristics of the exposed surfaces of test assemblies. Typically, building codes regulate surface flamespread on the basis of different test procedures as described in Chapter 8.

Fire Exposure—As discussed in Chapter 3, the original objective of the time-temperature curve was to develop a relatively severe, standardized fire exposure which would simulate “typical” building fires. At the time it was developed, very little information was available concerning the growth and development of actual building fires. Thus, the standard time-temperature curve largely represented the “best judgment” of the prevailing experts in the field.

In the years since, a considerable volume of scientific data has been developed which more accurately defines the factors which influence the severity of building fires. In particular, the effects of ventilation have been clearly established. It is now widely recognized that actual fires often produce temperature exposures of a greater intensity but shorter duration than contemplated in building code provisions based upon ASTM E 119. Nevertheless, the need for a standard test method to evaluate the comparative performance of construction assemblies, the vast amount of money invested in the conduct of standard fire tests, and the lack of an acceptable alternative, have all contributed to the continued use of the standard time-temperature curve.

Building officials and others responsible for applying the results of ASTM E 119 tests should also be familiar with other limitations of the specified fire exposure. Surprisingly, the test method has never included specific details or guidance relative to the construction of furnaces. Even the dimensions of the test facility are only indirectly controlled through the minimum sizes specified for test assemblies.

The basic control of the furnace environment is dependent upon the type, number, and location of thermocouples, which are specified in the test method. The standard requires that the average temperature recorded by these thermocouples closely follow the time-temperature curve. It should be noted, however, that these temperatures are not necessarily the same as the gas temperature within the furnace, nor do they totally define the exposure seen by the test specimen. Other factors which are not specified, such as the character of the flames within the furnace and radiation from the furnace walls, also influence the temperature recorded by thermocouples. Despite these potential inaccuracies, the nature of heat transfer during a fire test is such that it is generally recognized that the results of tests of about one hour or greater duration are not significantly affected. However, the results of tests of lesser duration may be more sensitive to furnace design and, therefore, vary from laboratory to laboratory. Hence, it is strongly recommended that fire endurance requirements of less than 45 minutes based on ASTM E 119 not be established in building codes.

An additional aspect of the specified exposure conditions that has received considerable attention in recent years is furnace pressure. It is well documented that fully developed building fires invariably generate positive pressure in the upper portions of the fire compartment. Although ASTM E 119 contains no specific references to furnace pressure, the corresponding test methods for door and window assemblies (ASTM E 152 and ASTM E 163, respectively) both require that the furnace pressure be maintained "as nearly equal to atmospheric pressure as possible." As a result, many laboratories conduct ASTM E 119 tests with a slight negative pressure in the furnace since this reduces the amount of smoke escaping into the laboratory.

It has been suggested that the test method be revised to require a positive furnace pressure. While such a revision may be more realistic in terms of actual building fires, it would necessitate the retesting of many currently accepted fire-resistant assemblies. At present, however, there is no actual field experience demonstrating that current practice results in unsafe conditions.

Although the stated purpose of the standard fire test is to provide a method for comparing the "relative" performance of various assemblies under fire conditions, technically the test does not subject different assemblies to the same exposure conditions. This results primarily from the fact that the furnace control is based upon a specific time-temperature relationship. As pointed out in Chapter 3, the intensity of

actual building fires is to some extent influenced by the thermal properties (thermal conductivity, specific heat, and density) of the walls, floor, and ceiling construction which enclose the fire compartment. Thus, a fire in a heavily insulated compartment will tend to produce higher temperatures than an otherwise similar fire in an uninsulated compartment or one constructed with materials which have high thermal capacities. Therefore, the use of a specific time-temperature exposure does not take into account the contribution of the construction assembly to the fire environment. This difference does not appear to be particularly significant with respect to the thermal properties of construction assemblies because of the overriding effects of ventilation and fire load.

Of potentially more importance is the contribution of combustible assemblies to fire intensity. The potential magnitude of this consideration was illustrated in a fire research project sponsored by American Iron and Steel Institute at The Ohio State University in the mid-1960's. The purpose of this project was to evaluate the comparative performance of various construction assemblies and the effect of furnace design and control on fire endurance. The performance of typical protected combustible and noncombustible assemblies, as well as conventional heavy timber construction, was assessed as part of this project. During many of the tests, the rate of fuel input necessary to maintain the standard time-temperature curve was measured. Figure 14 shows the difference recorded for the protected assemblies and a typical heavy timber construction. As can be seen, significantly less fuel was required to maintain the standard time-temperature curve for the heavy timber assembly. The difference represents the direct contribution of the burning heavy timber assembly to the fire environment.

In addition, several of the tests in this project confirmed that the degree of protection afforded by construction assemblies that have the same fire endurance depends upon whether the assemblies are of combustible or noncombustible construction. Although two similar assemblies may satisfy the structural and unexposed surface temperature criteria for the same period of exposure, protected combustible members, such as floor joists and wall studs, will usually begin to burn at some point during the test. In recognition of this, the Underwriters Laboratories report a "finish rating," in addition to a fire endurance classification, for "assemblies containing combustible supports."

The "finish rating" is the time at which the average temperature of wood (studs or joists) rises more than 250F (139C) or the individual

temperature at any single location rises more than 325F (181C) on the surface of the wood nearest the fire. Finish ratings are usually significantly less than the overall fire endurance classification of the assembly, as can be verified by reviewing the UL Fire Resistance Directory. While the finish ratings do not necessarily define the time at which actual ignition of wood structural members occurs, they do indicate the approximate time at which decomposition (pyrolization) begins.

As a result of the temperature buildup within assemblies containing “protected” combustible members, these members will invariably begin to decompose and ultimately burn, thereby contributing to the intensity of a building fire. As clearly demonstrated in The Ohio State

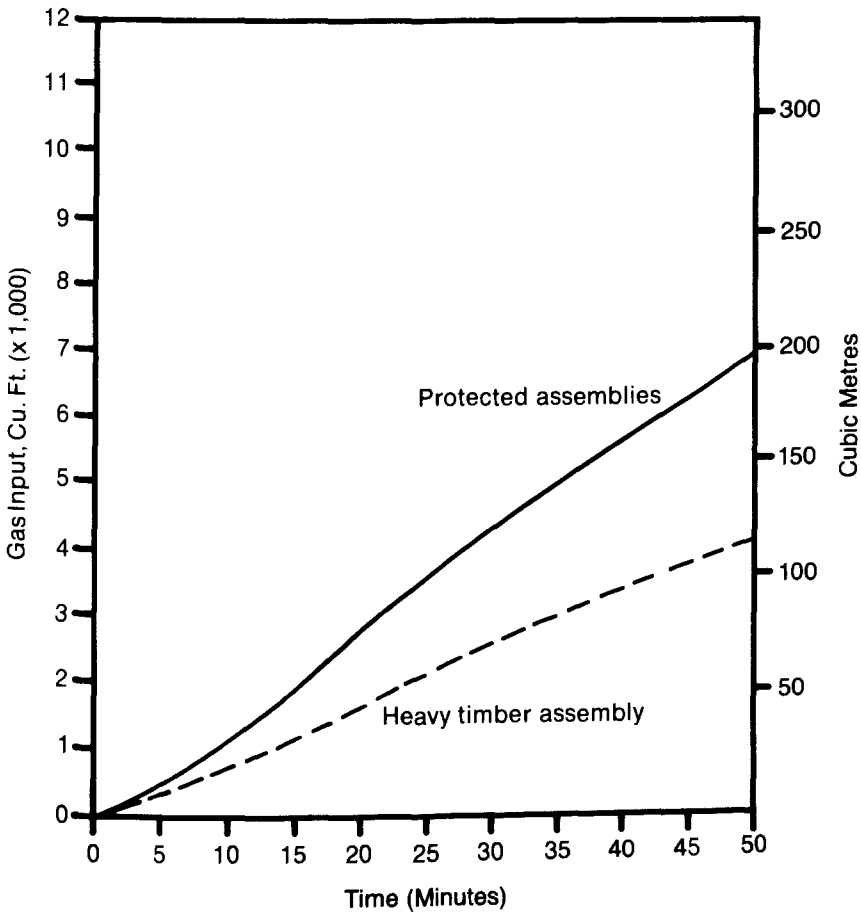

Figure 14. Comparative time-fuel input curves.

University project, once the ceiling or wall membrane fails, protected wood members will burn actively. This project also indicated that there was no significant difference in the time-fuel input required to maintain the standard time-temperature curve for protected combustible and noncombustible floor assemblies until the ceiling membrane failed. This project confirmed Ingberg's belief that the severity of fires in buildings of protected combustible construction is controlled by the occupancy fire load until the protection provided for combustible structural members fails. From that point on, the contribution of the combustible construction to the fire severity must also be considered. Thus, in addition to fire endurance, consideration should be given to whether an assembly is of combustible or noncombustible construction in the development of building code requirements.

Restrained And Unrestrained Classifications—During the past few years, probably no topic related to structural fire endurance has generated as much controversy as the question of restrained and unrestrained classifications for beams, floor and roof assemblies.

Historically, the use of ASTM E 119 fire endurance test data has been predicated on the assumption that the test assembly is "representative" of actual field construction. In practice, however, the application of this provision with respect to the testing of individual beams, floor and roof assemblies is not clearly specified and varies considerably among laboratories. The difficulty arises primarily from the size of available test facilities which can accommodate test specimens in the range of 15 feet by 18 feet (4.6 m by 5.5 m). Therefore, a typical test assembly represents a relatively small portion of an actual floor or roof structure.

Even though the standard fire test is frequently described as a "large-scale" test, it clearly is not a "full-scale" test. Most floor slabs and roof decks are continuous over supports. Beams, girders, and trusses are framed into columns and other structural members in a variety of ways. Testing laboratories are, therefore, faced with the difficult problem of providing both end support and restraint for test assemblies which are "representative" of actual field construction.

The importance of this consideration arises from the fact that most building materials tend to expand when exposed to elevated temperatures. If, in an actual building, an assembly is supported or surrounded by construction which is capable of resisting expansion, then stresses in addition to those due to dead and live loads will be imposed on the assembly. Originally, it was believed that these stresses would reduce

the fire endurance of the assembly. However, considerable research during the 1960's indicated that restraint against thermal expansion generally had the opposite effect and tended to increase fire endurance. As a result, in the early 1970's ASTM E 119 was revised to include two classifications for floor and roof assemblies and individual beams, "restrained" and "unrestrained". The "restrained" classification applies when, in an actual building, the assembly is surrounded or supported by construction which is "capable of resisting substantial thermal expansion throughout the range of anticipated elevated temperatures." Otherwise, the ends of the assembly should be considered free to rotate and expand and the assembly should be classified as "unrestrained."

Unfortunately, the degree of "restraint" inherent during most fire endurance tests has not been quantified and procedures for assessing the degree of "restraint" present in actual buildings have not been developed. In recognition of these shortcomings, an appendix entitled "Guide for Determining Conditions of Restraint for Floor and Roof Assemblies and for Individual Beams" has been added to the standard fire test. This appendix states the following with respect to the definition of a restrained assembly:

"This definition requires the exercise of engineering judgment to determine what constitutes restraint to 'substantial thermal expansion.' Restraint may be provided by the lateral stiffness of supports for floor and roof assemblies and intermediate beams forming part of the assembly. In order to develop restraint, connections must adequately transfer thermal thrusts to such supports. The rigidity of adjoining panels or structures should be considered in assessing the capability of a structure to resist thermal expansion. Continuity, such as that occurring in beams acting continuously over more than two supports, will induce rotational restraint which will usually add to the fire resistance of structural members."

As an aid to architects, engineers, and building officials, a listing of various common types of construction has been included in the appendix to ASTM E 119. This listing is given in Table 18 and provides a general indication of those types of construction which can be considered as restrained in actual buildings.

Walls And Partitions—With respect to walls and partitions, the standard fire test evaluates the ability of the assembly to function as a barrier against the spread of fire from one side to the other. Separate procedures are specified for loadbearing and nonbearing walls and partitions. In all cases, the area exposed to the fire must be at least 100

square feet (9.2 m²) and the assembly must be not less than 9 feet (2.7 m) in height or width. The acceptance criteria specify that the unexposed surface temperature must not rise more than 250F (139C) above the initial room temperature. In addition, the assembly must withstand the standard fire test without the passage of flame or gases hot enough to ignite cotton waste. For loadbearing walls, the superimposed applied load must be sustained throughout the duration of the test.

Table 18—Construction Classification, Restrained and Unrestrained

- I. Wall Bearing:
 - Single span and simply supported end spans of multiple bays:^a
 - (1) Open-web steel joists or steel beams supporting concrete slab, precast units, or metal decking..... unrestrained
 - (2) Concrete slabs, precast units, or metal decking unrestrained
 - Interior spans of multiple bays:
 - (1) Open-web steel joists, steel beams or metal decking supporting continuous concrete slab restrained
 - (2) Open-web steel joists or steel beams supporting precast units or metal decking unrestrained
 - (3) Cast-in-place concrete slab systems restrained
 - (4) Precast concrete where the potential thermal expansion is resisted by adjacent construction^b restrained
- II. Steel framing:
 - (1) Steel beams welded, riveted, or bolted to the framing members restrained
 - (2) All types of cast-in-place floor and roof systems (such as beams-and-slabs, flat slabs, pan joists, and waffle slabs) where the floor or roof system is secured to the framing members restrained

- (3) All types of prefabricated floor or roof systems where the structural members are secured to the framing members and the potential thermal expansion of the floor or roof system is resisted by the framing system or the adjoining floor or roof construction^b restrained

III. Concrete framing:

- (1) Beams securely fastened to the framing members restrained
- (2) All types of cast-in-place floor or roof systems (such as beam-and-slabs, flat slabs, pan joists, and waffle slabs) where the floor system is cast with the framing members..... restrained
- (3) Interior and exterior spans of precast systems with cast-in-place joints resulting in restraint equivalent to that which would exist in condition III (1) restrained
- (4) All types of prefabricated floor or roof systems where the structural members are secured to such systems and the potential thermal expansion of the floor or roof systems is resisted by the framing system or the adjoining floor or roof construction^b restrained

IV. Wood construction:

All types unrestrained

^aFloor and roof systems can be considered restrained when they are tied into walls with or without tie beams, the walls being designed and detailed to resist thermal thrust from the floor or roof system.

^bFor example, resistance to potential thermal expansion is considered to be achieved when:

- (1) Continuous structural concrete topping is used,
- (2) The space between the ends of precast units or between the ends of units and the vertical face of supports is filled with concrete or mortar, and
- (3) The space between the ends of precast units and the vertical faces of supports, or between the ends of solid or hollow core slab units does not exceed 0.25 percent of the length for normal weight concrete members or 0.1 percent of the length for structural lightweight concrete members.

A further requirement which applies to walls and partitions having a fire endurance classification of one hour or greater is a hose stream test. This test requires that a duplicate test assembly be subjected to the fire exposure for a period equal to one-half of the fire endurance classification or one hour, whichever is less. Then, the duplicate test assembly is subjected to the impact, erosion and cooling effects of a standard hose stream. The assembly must be able to withstand this exposure without developing openings that permit water to project from the unexposed surface of the test assembly. In many cases, the hose stream test is actually conducted on the original test assembly, thus eliminating the need for the second test assembly. A previous requirement for loadbearing walls that the assembly also be capable of sustaining twice the superimposed load following the fire and hose stream test has been discontinued.

ASTM E 119 requires that nonbearing walls and partitions be restrained along all four edges during the test. This arrangement represents the most severe support condition for non-load bearing assemblies. In contrast, loadbearing walls and partitions are tested with the vertical edges free to move laterally resulting in a more severe condition of load eccentricity.

One important consideration with respect to the construction of fire resistive walls and partitions is the manner in which combustible members are framed into the walls. If such members are framed into opposite sides of the wall, it is possible for fire to spread through the wall at these junctions and otherwise nullify the fire-resistance of the assembly. Building codes typically address this subject with respect to the construction of fire walls. This detail is, however, often overlooked in the erection of other fire-resistive walls and partitions.

Over the years, many standard fire tests have been conducted on walls and partitions with nonloadbearing steel studs. There has, however, only been a limited amount of information available on the fire resistance of assemblies with load bearing steel studs. Because of the increasing use of light gage steel framing systems, American Iron and Steel Institute sponsored a comprehensive fire research project at the Underwriters Laboratories to develop such information. The results of this project are described in detail in an AISI publication "Fire Resistance Ratings for Loadbearing Steel Stud Walls."

Columns—The standard fire test requires that column assemblies be exposed to fire on all sides and loaded throughout the duration of the test. The applied load is calculated so as to develop, as nearly as

possible, “the working stresses contemplated by the design.” The length of the column should, when practical, approximate the clear length expected in typical building designs, but in no case should it be less than 9 feet (2.7 m). During the test, the column must sustain the applied load “for a period equal to that for which classification is desired.” In other words, the time at which the column fails structurally determines the fire endurance classification.

For structural steel columns, ASTM E 119 includes an alternate procedure for determining the fire resistance of assemblies tested without load which takes into account the elevated temperature properties of structural steel. It is limited in application to assemblies in which the protective material is not designed to carry any of the superimposed load acting on the column. During the test, the temperature of the steel column is measured at four different levels. The conditions of acceptance specify that the average temperature recorded at any of these levels not exceed 1000F (538C) and the highest temperature recorded at any individual thermocouple location not exceed 1200F (649C). These limits were developed on the basis of tests conducted on loaded columns.

For many years it has been recognized that the size of a structural steel column and the profile of fire protection materials applied to the column significantly influence fire endurance. This influence has now been directly related to two well-defined parameters: the mass (or weight) of the column and the heated perimeter.

The importance of mass is illustrated in Figure 15, which shows two typical fire-resistant column assemblies. As shown, the W 14X233

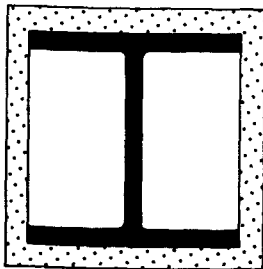

W10 x 49
1" (2 Hours)

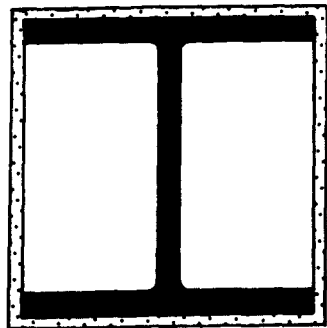

W14 x 233
1/2" (2 Hours)

Figure 15. The effect of mass on column fire endurance.

column requires only approximately one-half the thickness of fire protection to maintain the same classification as the W 10X49 column. A careful review of the UL Fire Resistance Directory will confirm that this general relationship is approximately true for many fire protection materials. The reason that mass is so important is the thermal capacity of steel; the more massive a section, the more total heat is required to raise its temperature to any given level. In fact, it has been demonstrated that totally unprotected, massive structural steel columns are capable of developing fire endurance classifications in the range of 1 hour.

The second factor which influences the fire endurance of structural steel columns is the heated perimeter, defined as the inside perimeter of the fire protection material enclosing the column. This factor is illustrated in Figure 16, which defines the heated perimeter for several common fire protection profiles and structural shapes. The heated perimeter is important since it characterizes the perimeter through which heat is transferred from a fire to a protected steel column. For example, it has been found that a contour profile on a typical wide flange column will require approximately 50 percent greater thickness

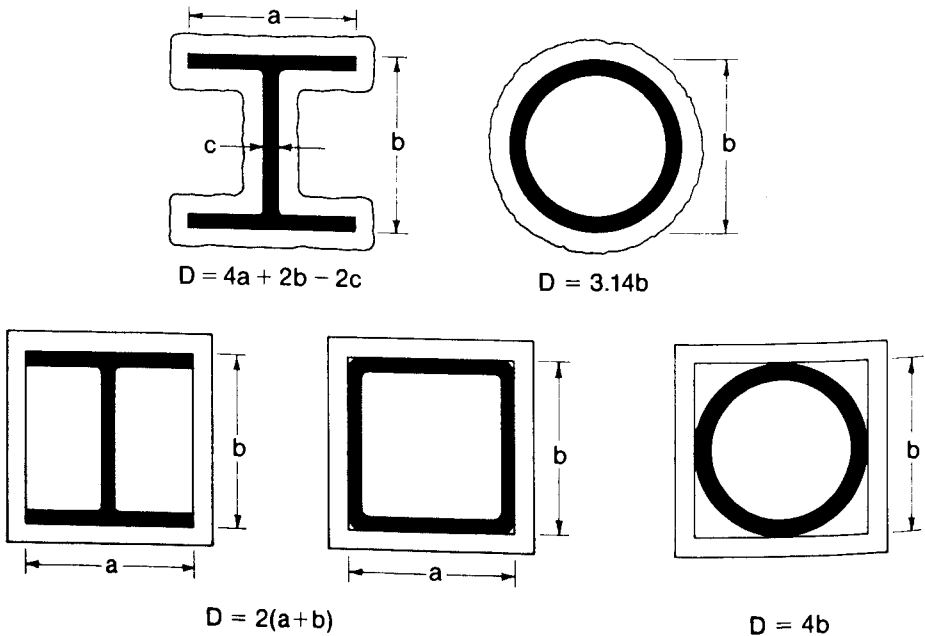

Figure 16. Determination of the heated perimeter of structural steel columns.

of protection to attain the same classification as an otherwise identical column with box protection.

Based upon these two parameters and the thickness of fire protection material, analytical procedures have been developed which permit the calculation of the fire endurance of various size structural steel columns protected with specific materials. These procedures and their limitations are described in detail in an American Iron and Steel Institute publication, "Designing Fire Protection for Steel Columns."

The significance of weight-to-heated-perimeter ratios is illustrated in Figure 17, which gives the fire endurance of structural steel columns

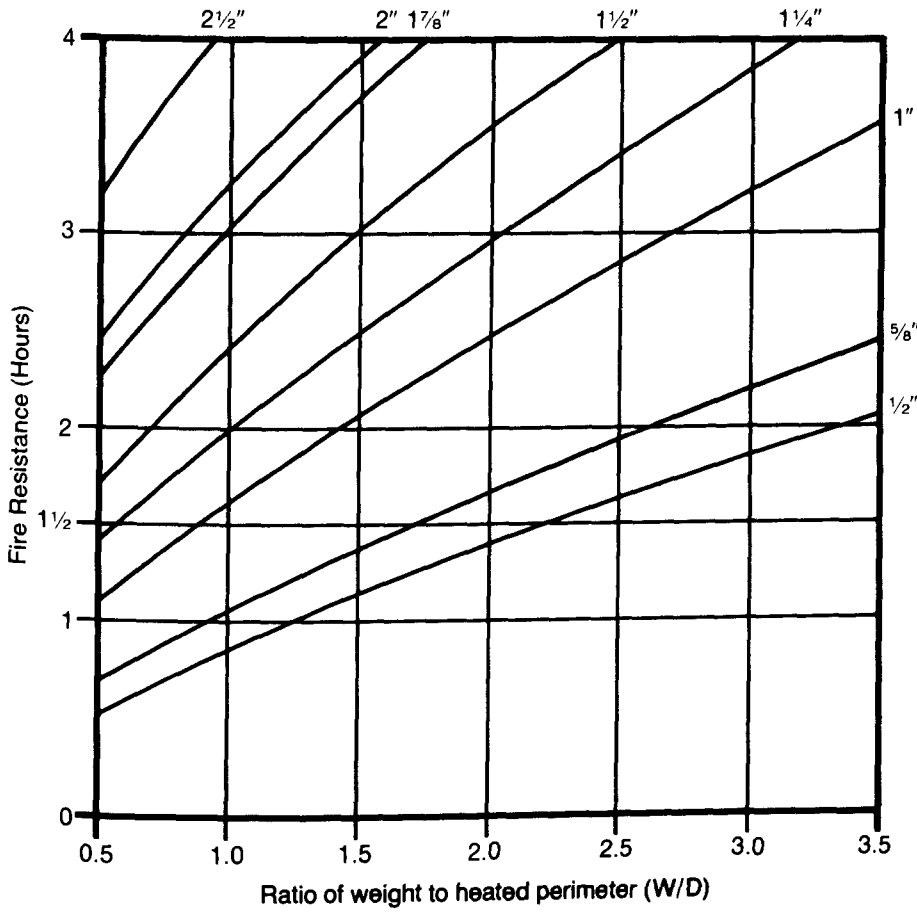

Figure 17. Fire resistance of structural steel columns protected by various thicknesses of gypsum wallboard.

protected with various thicknesses of gypsum wallboard. Similar relationships have been developed for other fire protection materials.

In general, fire protection materials applied to columns should extend the full height of the column. There should be no discontinuities such as cut-offs of the fire protection at ceiling lines or at other locations where assemblies abut the column. In addition, fire protection materials which may be damaged due to moving equipment or vehicles should be physically protected.

Beams and Girders—Although beams and girders are usually tested as a part of a floor or roof assembly, the ASTM E 119 test procedure does include provisions for testing them as individual members. Both restrained and unrestrained classifications are developed based on these tests. In these tests, a typical section of floor or roof construction, not more than 7 feet (2.1 m) in width, is constructed on top of the beam in a conventional manner and the beams are restrained against thermal expansion at their ends. If the floor construction is designed to act compositely with the beam, then the width of the floor which is assumed to act compositely is also restrained. Otherwise, the floor is not restrained against longitudinal thermal expansion.

During the test, the assembly is loaded so as to simulate, as nearly as practical, the theoretical maximum load conditions permitted by nationally recognized design standards. The restrained beam rating is determined by the time at which structural failure occurs. For steel beams and girders, the unrestrained rating is determined when the average temperature at any of three cross-sections exceeds 1100F (593C) or the individual high temperature recorded by any single thermocouple exceeds 1300F (704C). An additional limitation for the restrained beam is that the temperature limits for the unrestrained rating must not be exceeded within one hour after the start of the test and the restrained rating cannot exceed twice the unrestrained rating.

The standard fire test also has an alternate procedure for evaluating the fire endurance of structural steel beams and girders tested without load. These are similar to those previously described for columns and are intended to provide a means for evaluating the fire endurance of beams or girders which cannot be properly loaded in existing test facilities. The protected beam is tested with a section of typical floor construction. The fire endurance classification is determined when the average temperature of the beam, at any of four cross-sections, exceeds 1000F (538C) or the individual high temperature recorded by any single thermocouple exceeds 1200F (649C). Like the alternate column test,

this procedure is limited to assemblies where the fire protection material or system is not intended to carry any of the superimposed load applied to the beam.

As a result of the "heat sink" effect of most common forms of floor construction, the temperatures will generally vary markedly over the depth of a structural steel beam. Therefore, individual beam classifications are only valid for floor constructions which have a comparable or greater capacity for heat dissipation from the beam than the construction which was actually tested.

Weight-to-heated-perimeter ratios are also an important consideration with respect to beam classifications. The heated perimeter is, however, determined in a different fashion since the top flange of the beam is generally in contact with floor or roof construction and the beam is exposed to fire on only three sides. The heated perimeter for several common protection profiles for beams is shown in Figure 18. Based upon research sponsored by American Iron and Steel Institute, Underwriters Laboratories Inc. has developed a technique for adjusting the thickness of fire protection applied to structural steel beams which differ in size from those tested. This technique is based upon the weight-to-heated-perimeter ratio of the beams and has been published in the UL Fire Resistance Directory.

Trusses—Steel trusses represent a unique solution to many common structural problems. Trusses, as well as more complex structural systems such as arches, domes, and space frames are often used where

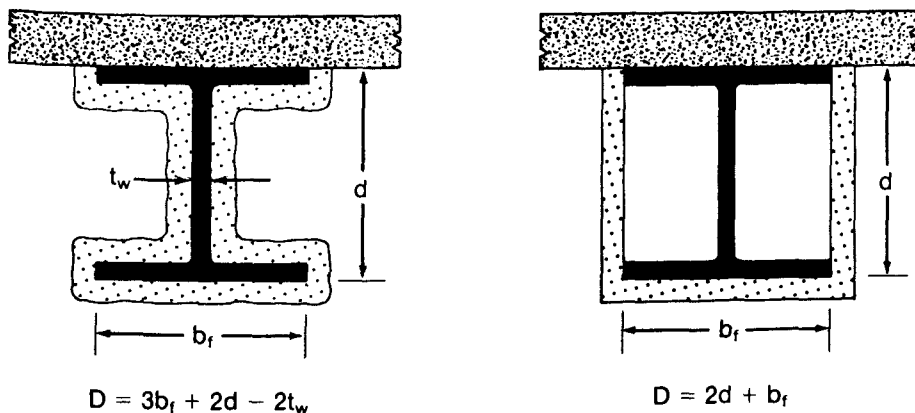

Figure 18. Determination of the heated perimeter of structural steel beams.

large, column-free areas are necessary. Building codes generally recognize the unique nature of such structural systems and frequently include special provisions which allow these members to be unprotected. There are, however, circumstances such as load transfer trusses, where fire endurance requirements are specified. In such cases, one method of achieving the desired fire protection is to encase each of the individual elements of the truss.

Because of the size of many trusses, it is not physically possible to conduct standard fire tests. A reasonable solution to this dilemma is to utilize the results of unloaded column tests as a basis for determining the required thickness of fire protection for the individual truss elements. When a large truss is exposed to a fully developed fire, the most severe condition will result when the individual elements are exposed to fire simultaneously on all sides in a manner similar to the exposure for columns. The endpoint criteria specified in the standard fire test for unloaded steel columns is based upon a limiting temperature of 1000F (538C). This temperature limit is consistent with the endpoint criteria established for tests on beams and girders. Thus, the use of column test data to design the protection for steel trusses is consistent with the requirements in ASTM E 119 for other structural members and provides a logical basis for dealing with a practical fire protection problem.

In addition to long-span structures, several other common truss applications are worthy of mention. One increasingly popular structural system for residential occupancies is the staggered truss system. In this system, the trusses are a full story in height and the floor slabs span between the top chord of one truss and the bottom chords of the adjacent trusses. The trusses are enclosed in wall construction which may also serve as the separation between guest rooms in a hotel or dwelling units in an apartment building. The trusses are sometimes designed with a clear opening at the center for the passage of corridors. In such cases, developing appropriate fire protection requirements involves a number of considerations since the truss is both a structural member and part of a wall assembly.

Another unique steel truss application used extensively in hospital construction is the interstitial truss system. In this system, deep trusses provide space between the ceiling and floor slab for direct access to ductwork, piping, and mechanical and electrical systems. Generally, the interstitial spaces are on the order of eight feet (2.4 m) in height to allow adequate access by maintenance personnel. Fire protection for the trusses is achieved through the use of fire-resistant ceiling

membranes supported from the bottom chord members. An interstitial system requires careful design of the ceiling membrane protection system and control of the combustibility of materials located within the interstitial space. Because of the popularity of this system, specific requirements covering interstitial spaces have been included for health care occupancies in the Life Safety Code (NFPA 101).

Fire protection for structural steel trusses can be achieved by individually protecting each of the elements of the truss, by enclosing the truss for its entire height and length in fire-resistant construction, or through the judicious use of ceiling membrane protection systems. A more thorough discussion of these protection techniques is given in an American Iron and Steel Institute publication, "Designing Fire Protection for Steel Trusses."

Floor And Roof Construction—The most complex provisions in the standard fire test are those which pertain to the testing of floor and roof assemblies. The major difficulty related to the testing of such assemblies results from the dual (restrained and unrestrained) classification procedures.

The fire endurance of floor assemblies is of particular importance since such assemblies generally constitute the major compartment boundaries in buildings. In some cases, such as open plan buildings, floor construction may represent the only compartment boundaries. Although stairways, elevator hoistways, and other vertical shafts in such buildings will generally be enclosed in fire-resistant construction, the function of such enclosures is to prevent the spread of fire and smoke into the shafts rather than to subdivide floor areas.

In order for a floor assembly to successfully perform as a barrier to the spread of fire, ASTM E 119 requires that the assembly withstand the specified exposure without the passage of flames or hot gases sufficient to ignite cotton waste. In addition, the transmission of heat through the assembly cannot result in an average, unexposed surface temperature rise of more than 250F (139C) above the initial room temperature. As previously mentioned, the unexposed surface temperature limits have been in the standard since its inception and are intended to define a conservative, lower bound for the temperatures which could result in the ignition of ordinary combustible materials. These criteria also apply to roof assemblies, although the intended purpose is not as clear for this application.

In recent years, it has been suggested that the unexposed surface temperature criteria for floor assemblies be relaxed by requiring that

they only apply for the first one-half of the fire endurance period or one hour, whichever is greater. Although the existing criteria may be overly conservative in terms of the manner in which the temperatures are recorded and the limits applied, proposals to apply them for only one-half the required fire endurance period have not been technically substantiated. They could result in a significant reduction in the ability of floor assemblies to restrict the spread of fire.

During the test, floor and roof assemblies must also sustain an applied load calculated so as to theoretically simulate the maximum load condition permitted by nationally recognized structural design procedures. In general, these assemblies can be tested in either a restrained or unrestrained condition. A thorough treatment of the structural criteria for "restrained" floor and roof assemblies is beyond the scope of this book. Those interested in a more detailed understanding of this concept are encouraged to review the standard fire test method and ASTM Special Technical Publication 422, "Fire Test Methods -Restraint and Smoke."

It is important, however, to recognize that an unrestrained classification can also be determined for assemblies tested in a restrained condition on the basis of temperature criteria which are specified for various structural members. Thus, two separate classifications can be developed from a single restrained test. If, on the other hand, the assembly is tested without substantial restraint against thermal expansion, then only an unrestrained classification can be determined. This explains why listings of fire-resistant assemblies, such as the UL Fire Resistance Directory, often appear to be inconsistent in that both restrained and unrestrained classifications are given for certain assemblies while only unrestrained classifications are shown for others.

Over the years, literally thousands of floor and roof assemblies have been tested to determine their fire endurance characteristics. These assemblies include virtually all types of common construction systems, such as open web steel joists, structural steel beams, and cold-formed steel floor and roof deck assemblies. Fire protection for such systems includes suspended or furred ceilings, as well as direct-applied fire protection. A detailed discussion of the various systems for the protection of steel construction is given in an American Iron and Steel Institute publication, "Fire-Resistant Steel Frame Construction."

Elevated Temperature Properties Of Steel

The properties of most building materials will be adversely affected

by the temperatures developed during severe fires. As early as 1926, Ingberg and Sale reported on the effects of elevated temperature on the compressive modulus of elasticity and yield strength of carbon steel. The behavior of steel at elevated temperatures has been the subject of extensive research for many years and a wealth of information is available in the technical literature on this subject. Unfortunately, the vast bulk of this information is directed toward steels for continuous, high-temperature service applications such as heating equipment, incinerators, and boilers. Only a limited amount of information is available concerning short-time elevated temperature properties which more accurately reflect the conditions present during building fires or standard fire endurance tests.

From the standpoint of analyzing the performance of steel structural members, the most important mechanical properties are the modulus of elasticity, yield strength, and coefficient of thermal expansion. The first two of these properties at elevated temperature have generally been evaluated on the basis of tension tests similar to those used to evaluate these properties at ambient temperatures. In these tests, samples are uniformly heated to a constant temperature and an increasing tensile load is applied at a constant rate until failure has occurred. Figure 19 illustrates a series of typical stress-strain relationships for ASTM A36 steel at various temperatures. As can be seen, above approximately 400F (204C), the distinct yield plateau begins to disappear and the curves become more rounded.

Figures 20, 21, and 22 illustrate the effects of temperature on the modulus of elasticity and tensile and yield strengths of carbon steel meeting the requirements of ASTM A 36. Generally, as the temperature of steel rises up to approximately 500F (260C), the tensile strength actually increases. Beyond 500F (260C), the tensile strength begins to decrease. The yield strength and modulus of elasticity of steel begin to decrease gradually at temperatures beyond 200F (93C). In addition, it has been found that the yield and tensile strengths of high-strength steels such as ASTM A 242 and ASTM A 441 remain proportionately greater at elevated temperatures than the corresponding yield and tensile strengths of ASTM A 36 structural steel. Therefore, structural members hot-rolled from high-strength steels may be substituted for ordinary mild steel (ASTM A 36) members in fire resistant designs without adversely affecting the overall fire endurance classification of the assembly. This conclusion may not, however, be valid for heat treated steels or cold-formed steel members.

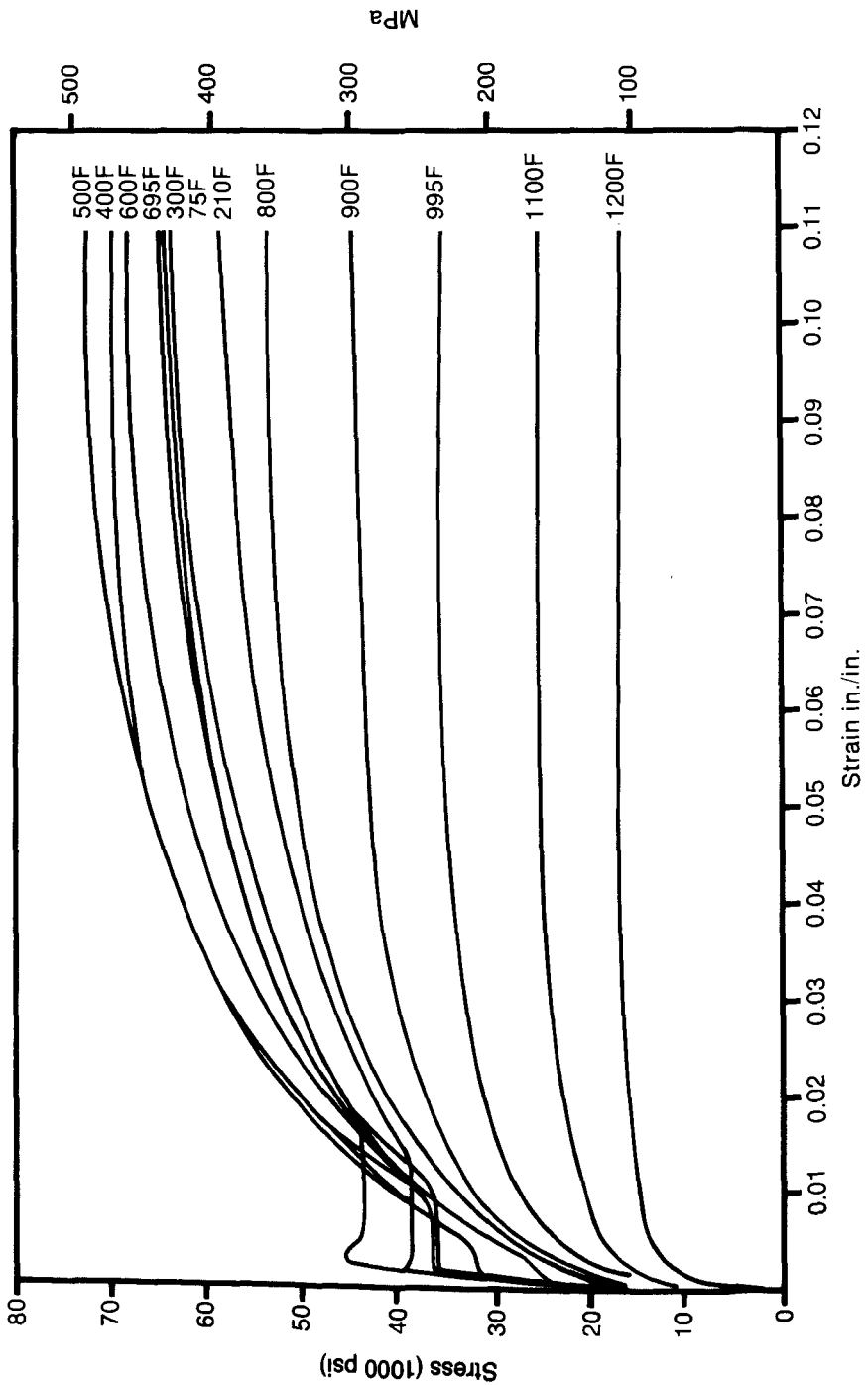

Figure 19. Stress-strain curves for an ASTM A36 steel developed by Harmathy and Stanzak, ASTM STP 464.

The elevated temperature relationships shown in Figures 20, 21, and 22 indicate general trends. They are not intended to establish precise relationships for the purpose of analytically evaluating the response of structural steel members to fire conditions.

In addition to mechanical properties, an evaluation of the performance of steel structural members subjected to fire also requires a knowledge of the temperature distributions within the steel member. For example, in a building fire as well as during standard fire tests, steel beams are rarely heated uniformly over their entire cross-section. Substantial temperature differences, as great as 600F (333C), have

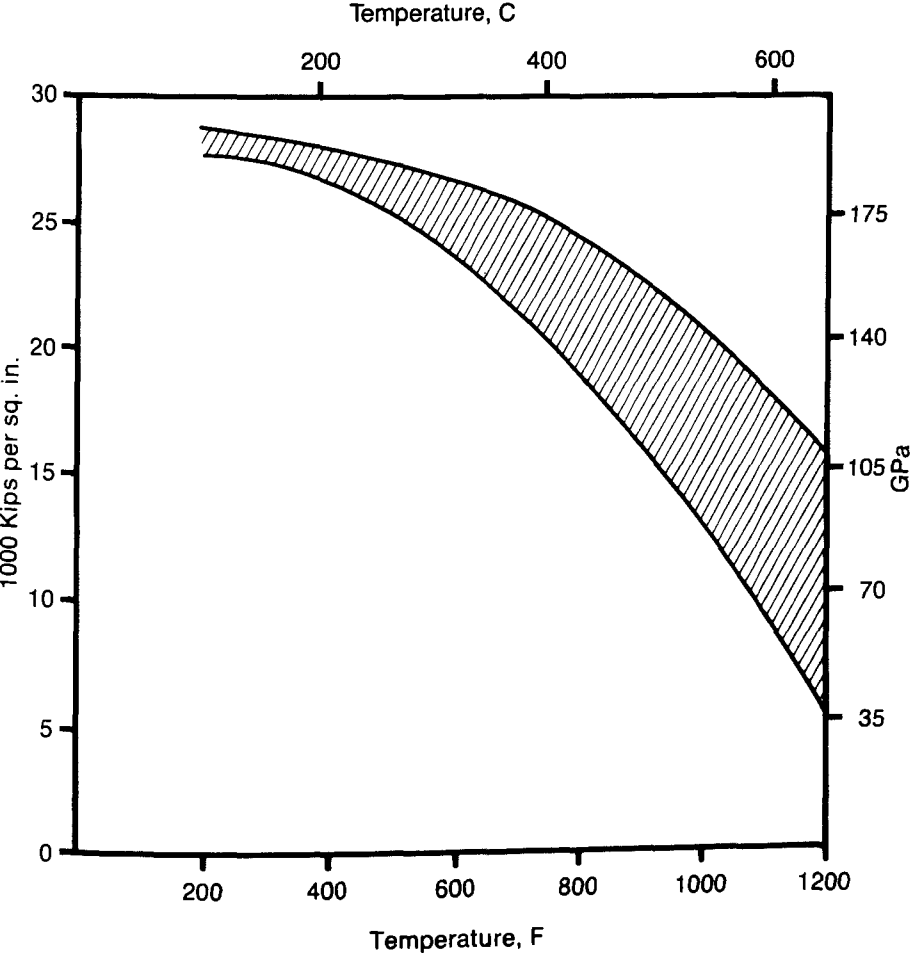

Figure 20. Modulus of elasticity of ASTM A36 structural steel at elevated temperatures.

been recorded during standard fire tests between the upper and lower flanges of a beam. This difference is accounted for by the direct contact of the upper flange of the beam with a concrete floor above. The concrete floor acts as a heat sink and absorbs heat from the upper flange of the beam while the lower flange is exposed to fire on all sides with no opportunity for heat dissipation.

Figure 23 illustrates the difference between the temperatures of the upper and lower flanges of a beam recorded during a series of fire endurance tests on protected steel floor and beam assemblies performed at The Ohio State University. Temperature differences also may occur across the section of a massive steel shape during periods of rapid temperature change at the surface. Under this condition of exposure much of the cross-sectional area of the member may be at lower temperatures than the surface, where the temperatures are typically measured during tests.

Steel, during its production and normal fabrication, is subject to higher temperatures than occur in even the severest building fires.

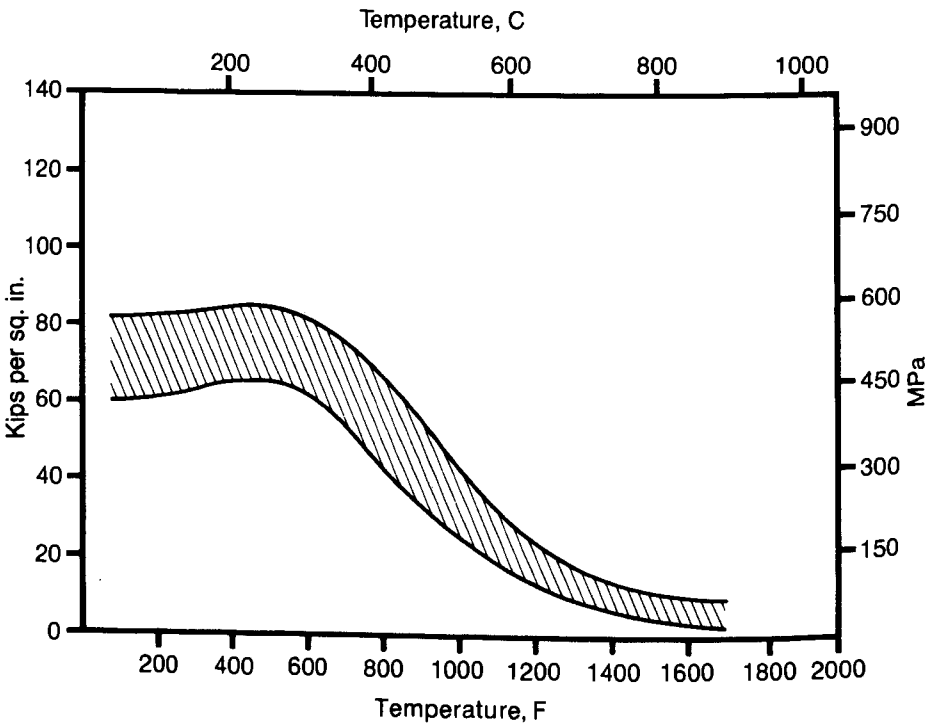

Figure 21. Tensile strength of ASTM A36 structural steel at elevated temperatures.

Therefore, the fact that steel members have been reheated and cooled by exposure to a fire does not render the members unfit for continued use. For most types of structural steel used in building construction, no permanent loss of strength results from fire exposure. In general, it has been determined that if a steel member can be straightened in place by the careful application of heat, such as by flame straightening, there will be no significant effect on its original strength. Notable exceptions are heat-treated steels and cold-formed steel members. Nevertheless, all fire damaged structures should be carefully evaluated by a structural engineer prior to repair or continued use.

Fire Protection Materials

The fire endurance of walls, partitions, columns, floor and roof assemblies, and other structural elements depends to a large extent on the properties of fire protection materials and the manner in which they are applied. In general, fire protection materials should be noncombustible or at least of limited combustibility to the extent that they do not

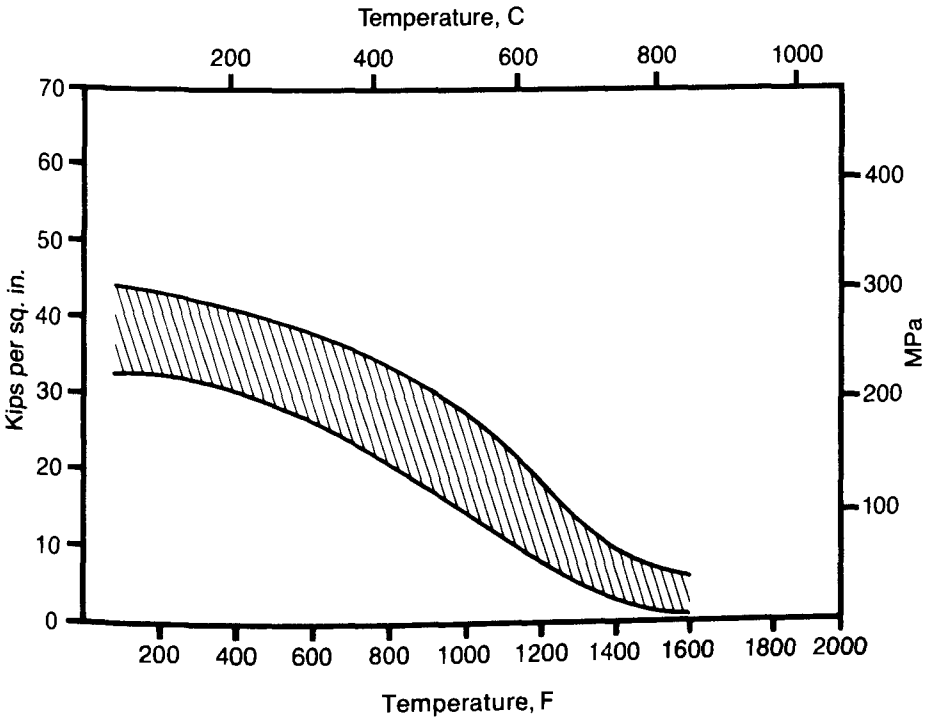

Figure 22. Yield strength of ASTM A36 structural steel at elevated temperatures.

release undue quantities of smoke or toxic gases, do not contribute directly to the growth and spread of fire, or otherwise increase the fire hazard present in a given building. These characteristics are not directly evaluated during fire tests but may, to varying degrees, be controlled by other building code provisions relating to the use of combustible materials and interior finish.

In addition, these materials must provide adequate thermal protection to achieve the required level of fire endurance. This characteristic is, of course, directly evaluated during standard fire endurance tests for one specified fire exposure condition. From a heat transfer standpoint, the important properties of most materials are thermal conductivity, specific heat, density, and moisture content. These properties and the effects of their interaction can be evaluated from tests much smaller in scale than the standard fire test. Fire protection materials and their attachment systems must also be sufficiently strong and durable to remain in place under normal operating conditions and during building fires. At the present time, these characteristics cannot be accurately evaluated solely on the basis of small-scale tests and the integrity of attachment systems must be assessed on the basis of ASTM E 119 tests.

All required fire-resistant assemblies should be carefully inspected

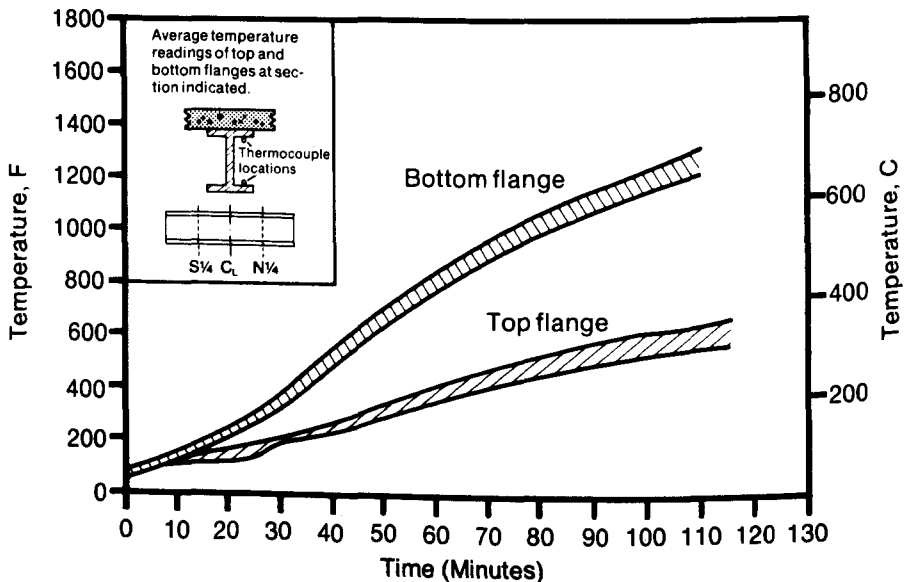

Figure 23. Temperature of top and bottom flanges of protected steel beams during exposure to ASTM E119 Standard Fire Test.

during and after construction to assure that they are installed according to the manufacturer's recommendations and the appropriate fire resistant design. Some of the more commonly used fire protection materials are described below.

Gypsum—Gypsum, in many forms, is used extensively as a fire protection material. As a plaster, it is applied to either metal or gypsum lath. It is also used in the form of gypsum block and wallboard. The fire resistant qualities of gypsum arise from the fact that it contains approximately 20 percent (by weight) chemically combined water. When exposed to fire, this water is slowly driven off in the form of steam by a process referred to as calcination. This reaction retards the transfer of heat through the gypsum so that the temperatures on the unexposed surface of the material do not greatly exceed 212F (100C) until the gypsum is completely calcined. The effectiveness of gypsum-based fire protection materials can be increased significantly by the addition of lightweight mineral aggregates, such as vermiculite and perlite.

For gypsum plaster applications, it is important that the mix is properly proportioned, applied in the required thickness, and that the lath is correctly installed. Gypsum plaster can be either hand-trowelled or spray-applied. In the case of gypsum wallboard, two general types are readily available, regular and Type X. Type X wallboards have specially formulated cores that provide greater fire resistance than conventional wallboard of the same thickness. In addition, many manufacturers produce proprietary wallboards with even greater fire-resistance characteristics. It is important to verify that the wallboard used is that specified for the particular fire-resistive assembly. In addition, the attachment system—including the type and spacing of fasteners and, when appropriate, the type and support of furring channels—is important.

Spray-Applied Materials—Spray-applied fire protection materials generally fall into two broad categories, mineral fiber and cementitious. These materials are most often supplied in a dry form and are based upon proprietary formulations. It is imperative that the manufacturer's recommendations with respect to mixing and application be closely followed.

Mineral fiber based materials are generally applied with specially designed equipment which feed the fibers and binding agents to a nozzle where water is added as the mixture is sprayed. Originally, many of these materials utilized asbestos fibers. However, concern over health hazards associated with asbestos has eliminated its use in

fire protection applications. Today, mineral fiber manufacturers have developed asbestos-free formulations.

Cementitious materials generally consist of plaster-based mixtures supplemented by the addition of light-weight inorganic aggregates, such as perlite or vermiculite. The materials are site-mixed with water just before spraying.

Good adhesion to the protected substrate is an important requirement for spray-applied fire protection materials. When these materials are to be applied to steel members, the surfaces should be free of dirt, oil, and loose scale. Generally, the presence of a light amount of rust will not adversely affect bond strength. Two characteristics of spray-applied materials which should be checked in the field are applied density and thickness. The American Society for Testing and Materials has developed a test method (ASTM E 605) for measuring these properties. A proposed test method for measuring other physical characteristics of these materials has also been published by ASTM.

In most cases, spray-applied fire protection materials are applied prior to the installation of ductwork, piping, conduit, and similar equipment, and some of the fire protection material may be removed or damaged by other trades. Obviously, if enough material is removed, the overall fire-resistance of the assembly can be impaired. Steps should be taken to assure that all damaged spray-applied materials are repaired before issuance of final approval for the building.

Concrete—While concrete was one of the original and most widely used materials for the fire protection of structural steel, it is not particularly efficient for this application due to its relatively high thermal conductivity. Concrete does, however, have significant thermal capacity in comparison with other fire protection materials and therefore is effective when used in sufficient thickness. The high thermal capacity of concrete is due, in part, to the presence of water, both chemically combined and free. Interestingly, concrete is one of the few common building materials which is capable of retaining significant quantities of uncombined moisture. When exposed to fire, this water is released in a manner somewhat similar to gypsum, although to a lesser degree. In intense fires, or when concrete has a relatively high free moisture content, rapid conversion of this moisture to steam can result in severe spalling.

In addition to thickness, the fire resistance of concrete depends on the mix proportions and the type of coarse aggregate. Generally, the use of siliceous aggregates, such as sandstone, results in lower fire resistance

ratings than limestone and other calcareous aggregates. Structural lightweight concretes with expanded clay, shale, or slate aggregates have better fire resistance than normal weight concrete. Additional improvements can also be realized through the use of vermiculite and perlite. To control cracking and to prevent possible dislodgment, it is recommended that cast-in-place concrete used for the protection of structural steel be reinforced with wire mesh or expanded metal lath. Although the use of concrete as a fire protection material for structural steel is no longer common, it is still used where specific architectural effects such as exposed aggregate finishes are desired, or where substantial resistance to physical damage is necessary.

Masonry—Masonry materials, such as brick, tile, and concrete block, are also traditional fire protection materials for structural steel. Like concrete, these materials are not particularly efficient for this application and their use is generally limited to applications where specific aesthetic effects are desired or where substantial resistance to damage is necessary. Particular attention should be paid to the composition, type, and geometry of the masonry unit. Details of installation and workmanship are also important considerations in the use of masonry for fire protection applications.

Architecturally Exposed Steel

As a result of recent innovations with respect to fire protection, the concept of architecturally exposed steel deserves special comment. In essence, this concept involves the direct architectural expression of a structural system rather than concealing a building frame behind a decorative facade. In the United States, various forms of architecturally exposed steel have been used in building construction for many years. Recently, this concept has become increasingly popular due to the development of “weathering” steels which may be left unpainted under most atmospheric conditions.

Building code requirements for fire resistant construction have played an important role in shaping the character of architecturally exposed steel. Figure 24 illustrates one of the more conventional methods for obtaining fire resistance where architecturally exposed steel construction is desired. As shown in this example, column fire protection is achieved in a traditional manner with the application of spray-applied materials. The column assembly, including the fire protection, is then enclosed in column covers which architecturally express the character of the concealed structural frame. Variations of this basic

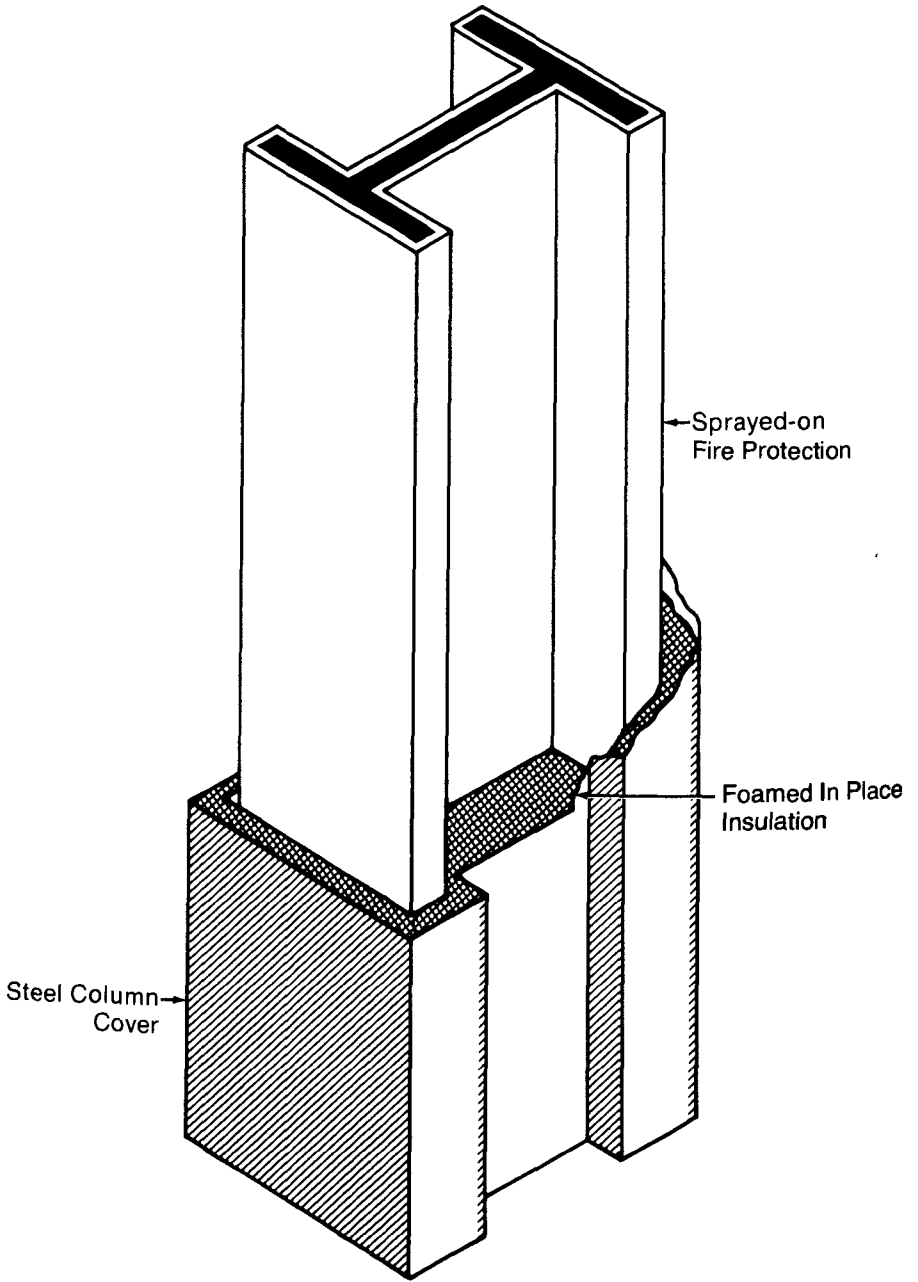

Figure 24. Exterior column with architecturally exposed steel column covers.

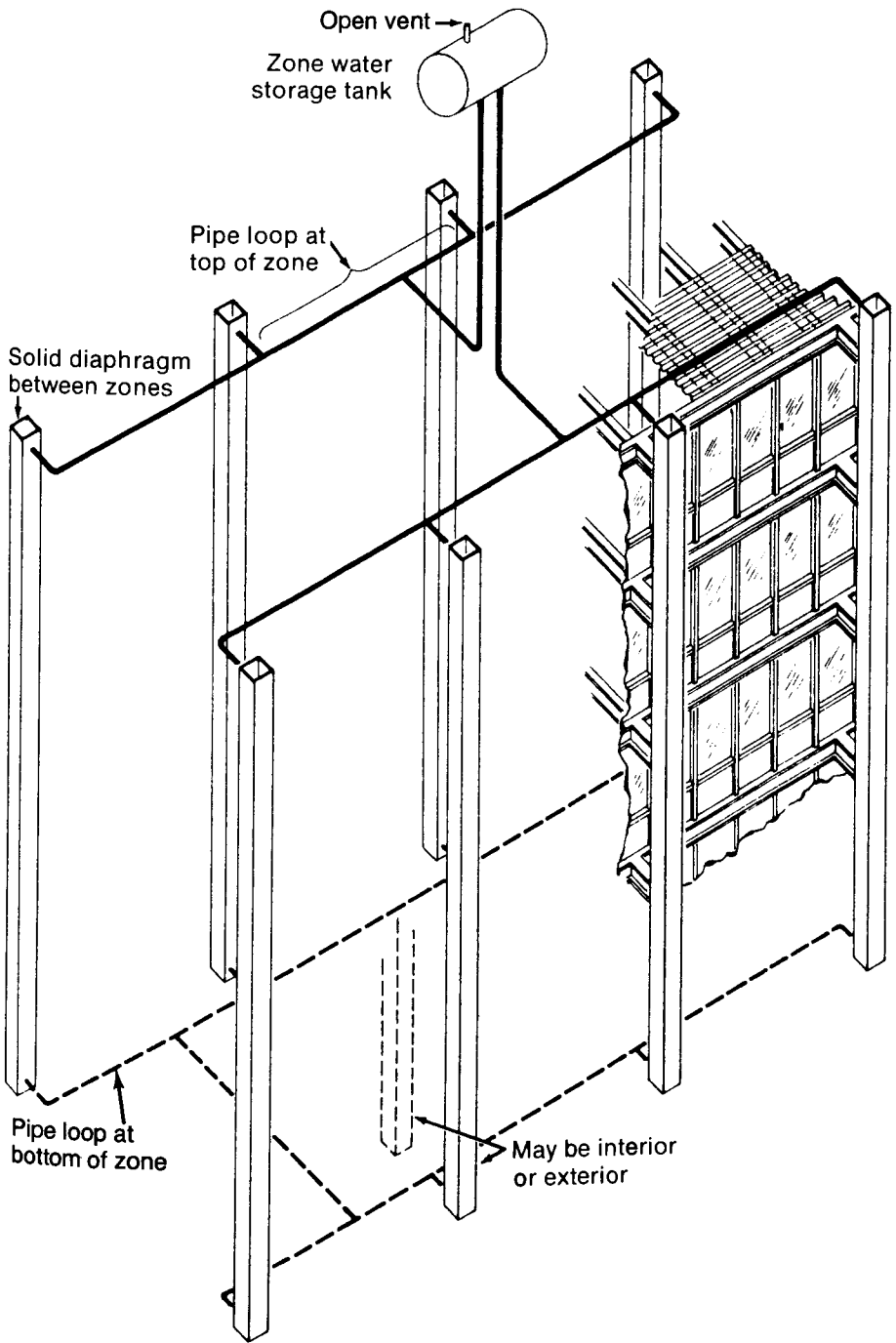

Figure 25. Schematic arrangement of fire-protection system for liquid-filled columns.

concept have been used in the design of numerous fire-resistive, architecturally exposed steel buildings.

In recent years, more economical techniques for providing the necessary fire protection for exposed steel construction have been developed. One such technique is the water-filled column concept. Although originally patented in 1884, this system was first used in 1967 when construction started on a 64-story office building in Pittsburgh. Since that time, a number of other buildings have been designed in both the United States and Europe using this concept. This method of fire protection permits the direct architectural exposure of main structural members without the need for costly fire protection materials and column covers.

Essentially, the system consists of hollow, liquid-filled columns interconnected with pipe loops designed to allow the water to circulate freely. A typical piping layout is schematically illustrated in Figure 25. When the column is exposed to fire, the steel temperature is controlled by the steel thickness and the temperatures of the liquid and the fire. The maximum liquid temperature is determined by its boiling point, which is a function of pressure. The further the exposed portion of a column is below a free liquid level (vented storage tank), the greater will be the water pressure within the column and therefore, the higher its boiling point. A representative temperature gradient for a water-filled steel column is shown in Figure 26. Engineering studies, confirmed by tests, have shown that critical temperatures will not be reached in steel columns so long as the columns remain filled with liquid.

Although the application of this concept requires careful engineering analysis, the basic principles are well established. Corrosion inhibitors should be added to the water and, in cold climates, antifreeze must be used for exterior column applications. Care must be exercised in applying this system to the fire protection of horizontal members to avoid pockets of trapped air or steam. Since these systems can be designed on the basis of the standard time-temperature curve—as well as any other fire exposure—they can also be used for the protection of interior columns.

A second recent innovation with respect to the fire protection of architecturally exposed steel is flame shielding of spandrel girders as illustrated in Figure 27. As shown, the spandrel girder is protected on the interior of the building in the conventional fashion. A sheet steel cover protecting the insulated bottom flange of the girder acts as a flame

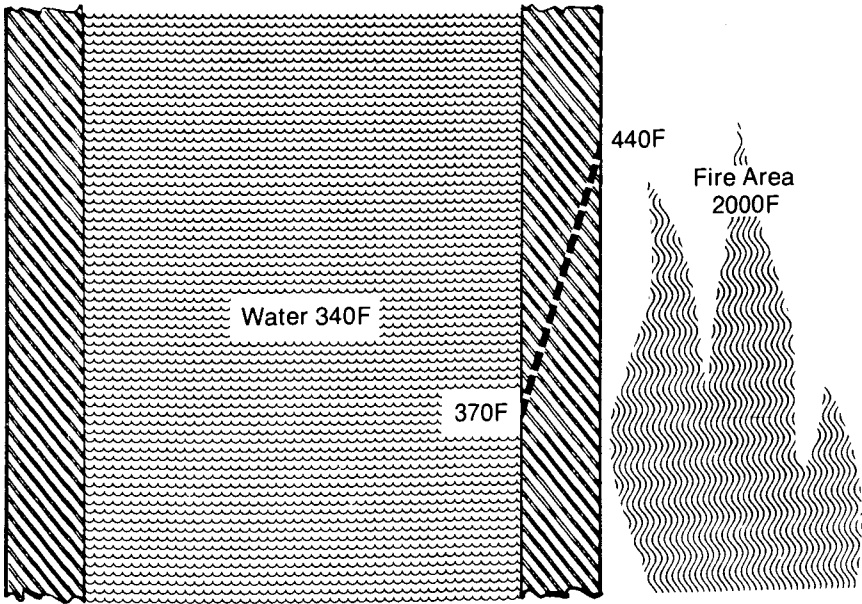

Section through tubular steel column wall.

Column Wall Thickness1" (25.4mm)
Fire Temperature2000F (1093C)
Steel Temperature at Exposed Face440F (227C)
Steel Temperature at Interior Face370F (188C)
Water Temperature340F (171C)

Figure 26. Steel temperatures in a liquid-filled column during exposure to fire.

shield which deflects the flames emerging from windows away from the exposed web of the girder. Under this condition, the maximum web temperature of the girder is largely controlled by radiant heat transfer from the flame emerging from the windows. This fire protection concept was first used in the design of a 54-story office building in New York City.

The validity of the design was verified by a wood crib burnout test on a full-scale mockup of one bay of this building. In addition, a second test was conducted by Underwriters Laboratories Inc. in a gas-fired furnace designed to simulate the spandrel girder configuration above a window opening. The furnace temperature during this test followed the standard time-temperature curve for a period of three hours. The average compartment and girder temperatures for both tests are shown in Figure 28. Several typical flame patterns are also shown for both

tests in Figure 29. Interestingly, as can be seen, the flame extension for the simulated ASTM E 119 test after three hours of exposure was still not as severe as during the wood crib test after fifteen minutes. In addition, the maximum girder temperature during the longer, gas-fired test was less than during the shorter duration full-scale burnout, 580F (304C) and 640F (338C), respectively.

As was pointed out in Chapter 3, the standard fire test does not simulate the fire exposure of exterior columns, spandrel girders, and similar members. Nevertheless, the absence of a definitive alternative has forced architects, engineers, and building officials to rely upon tests conducted in accordance with ASTM E 119 in the design and evaluation of architecturally exposed steel buildings. Although a number of innovative concepts—such as water-filled columns and flame-shielded spandrel girders—have been developed and accepted, the design of

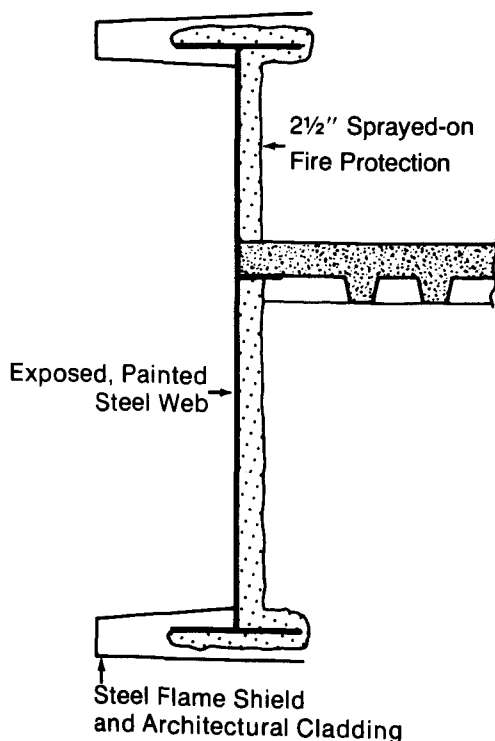

Figure 27. Fire-resistive flame shielding on spandrel girder of "One Liberty Plaza" building in New York City.

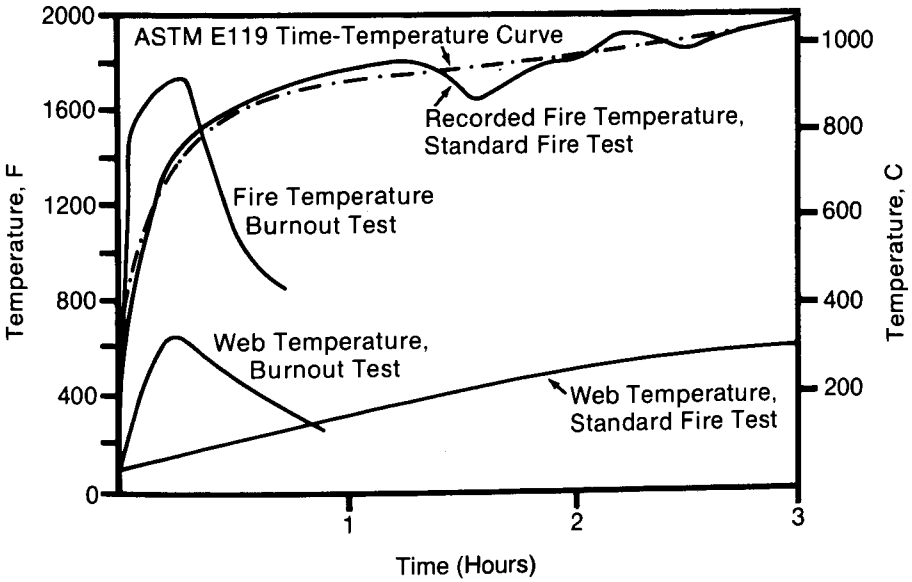

Figure 28. Average furnace and exterior steel spandrel temperatures during burnout and 3-hour standard fire tests.

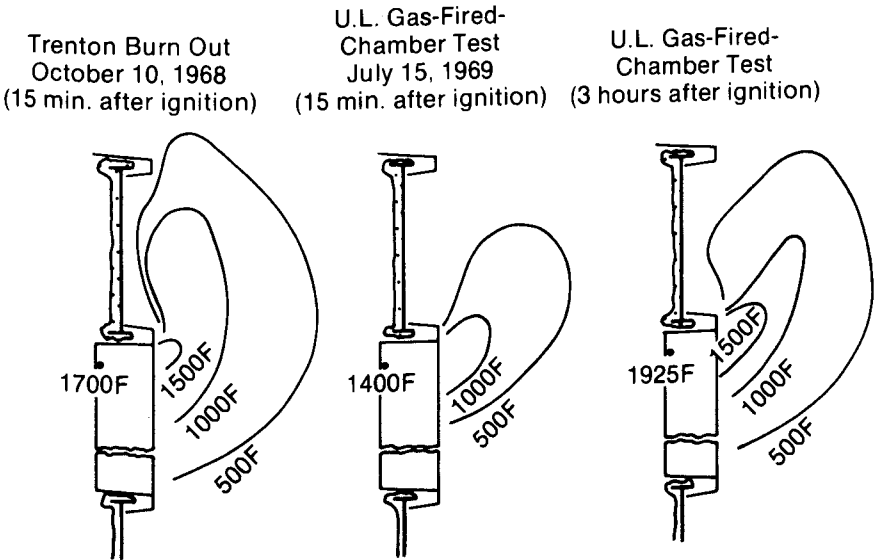

Figure 29. Flame patterns during the two fire tests on flame shielded spandrel girder.

these fire protection systems has still been largely based on the standard fire test.

During the past two decades, American Iron and Steel Institute has sponsored a number of research efforts directed toward better defining the fire exposure conditions for exterior structural members. European researchers have also been working on this unique fire protection problem. As a result of this joint interest, in the early 1970's AISI sponsored a worldwide survey of existing research and test data related to the protection of exterior structural members. From this effort, a comprehensive theoretical design approach was developed for analyzing the fire exposure of exterior structural steel members. This design method has been published by American Iron and Steel Institute in a "Design Guide for Fire-Safe Structural Steel." It provides a detailed method for evaluating the safety of exterior structural members under fire exposure. It provides architects, engineers, and building code authorities with a well-documented alternative to the standard fire test. The design guide has been evaluated and accepted by two of the model building code organizations in the United States as an alternate to the standard fire test.

Summary

Structural fire endurance requirements in modern building codes are based on tests conducted in accordance with the "Standard Methods of Fire Tests of Building Construction and Materials," ASTM Designation E 119. Classifications determined in accordance with this test are expressed in terms of hours or fractions thereof. The proper application of these test results in building design requires a thorough understanding of the significance and limitations of this test method. Essentially, the standard fire test is a comparative test. It provides a basis for evaluating the relative performance of different assemblies under controlled laboratory conditions.

The results of this test are not necessarily indicative of the manner in which assemblies will perform when exposed to real building fires, which may differ significantly from the exposure specified in the standard fire test. Despite this shortcoming, the absence of definitive alternatives has forced building code authorities to continue to rely upon the test as the basis for establishing performance oriented requirements. Recently, however, an alternative has been developed for exterior structural members.

Separate procedures are specified in ASTM E 119 for walls and

partitions, columns, beams and girders, and floor and roof assemblies. A wide variety of materials are used for the fire protection of steel construction. Fire resistant assemblies vary from relatively simple construction to complex systems. In all cases, it is imperative that such assemblies be carefully inspected during construction.

References

AMERICAN INSURANCE ASSOCIATION, *Fire-Resistance Ratings*, New York, NY, Dec. 1964.

AMERICAN IRON AND STEEL INSTITUTE

—*Design Guide for Fire Safe Structural Steel*, First Edition, November, 1980.

—*Designing Fire Protection for Steel Columns*, Third Edition, March, 1980.

—*Designing Fire Protection for Steel Trusses*, First Edition, 1976.

—*Fire-Resistant Steel-Frame Construction*, Second Edition, 1974.

—*Structural Properties of High Strength Steels at Elevated Temperatures*, January, 1965.

AMERICAN SOCIETY FOR TESTING AND MATERIALS

—*Standard Methods of Fire Tests of Building Construction and Materials*

(*ASTM E 176-80*), Philadelphia, PA, 1980.

—*Standard Methods of Fire Tests of Building Construction and Materials*

(*ASTM E 119-80*), Philadelphia, PA, 1980.

—*Standard Methods of Fire Tests of Door Assemblies*

(*ASTM E 152-80*), Philadelphia, PA, 1980.

—*Standard Methods of Fire Tests of Window Assemblies*

(*ASTM E 163-80*), Philadelphia, PA, 1980.

—*Standard Test Method for Cohesion/Adhesion of Sprayed Fire-Resistive Materials Applied to Structural Members*

(*ASTM E 736-80*), Philadelphia, PA, 1980.

—*Standard Test Methods for Thickness and Density of Sprayed Fire-Resistive Material Applied to Structural Members*

(*ASTM E 605-77*), Philadelphia, PA, 1980.

BLETZACKER, R.W., *Effect of Structural Restraint on the Fire-Resistance of Protected Steel Beam Floor and Roof Assemblies (EES-246/266)*, Engineering Experiment Station, The Ohio State University, Columbus, OH, December, 1966.

BLETZACKER, R.W., LANE, W.W., AND DENNING, D.W., *Fire-Resistance of Construction Assemblies (EES-245)*, Engineering Experiment Station, The Ohio State University, Columbus, OH, December, 1969.

GYPSUM ASSOCIATION, *Fire Resistance Design Manual*, 1978 Edition, Evanston, IL, 1978.

HARMATHY, T.Z., Design of Fire Test Furnaces, *Fire Technology*, Volume V, No. 2, May, 1969, pp 140-150.

HARMATHY, T.Z., AND STANZAK, W.W., "Elevated-Temperature Tensile and Creep Properties of Some Structural and Prestressing Steels," American Society for Testing and Materials, *Special Technical Publication No. 464*, Philadelphia, PA, 1970.

INGBERG, S.H., AND SALE, P.D., "Compressive Strength and Deformation of Structural Steel and Cast-Iron Shapes at Temperatures up to 950 Degrees C (1942 Degrees F)," *Proceedings*, American Society for Testing and Materials, Vol. XXVI, Part II, Philadelphia, PA, 1926.

LIE, T.T., AND STANZAK, W.W., "Fire Resistance of Protected Steel Columns," American Institute of Steel Construction, *Engineering Journal*, Vol. X, No. 3, 1973.

—"Fire Resistance of Unprotected Steel Columns," American Society of Civil Engineers, *Journal of the Structural Division*, Vol. 99, No. ST5, May, 1973.

NATIONAL FIRE PROTECTION ASSOCIATION, *Code for Safety to Life from Fire in Buildings and Structures (NFPA 101-1981)*, Boston, MA, 1981.

OVE ARUP & PARTNERS, "Design Guide for Fire Safety of Bare Exterior Structural Steel," *Technical Reports: 1. Theory and Validation and 2. State-of-the-Art*, London, January, 1977.

SEIGEL, L.G., "Design of Liquid-Filled Structural Members for Fire-Resistance," *Acier-Stahl-Steel*, June, 1969.

— "Effect of Furnace Design on Fire Endurance Test Results," American Society for Testing and Materials, *Special Technical Publication No. 464*, Philadelphia, PA, 1970.

— "Fire Test of an Exterior Exposed Steel Spandrel," *Materials Research and Standards*, Vol. X, No. 2, February, 1970.

— "Performance Requirements for Fireproofing Materials," American Society of Civil Engineers, *Journal of the Engineering Mechanics Division*, Vol. C, No. EM, June, 1974.

— "Water-Filled Tubular Steel Columns-Fire Protection Without Coating," *Civil Engineering*, Vol. XXXVII, No. 9, September, 1967.

UNDERWRITERS LABORATORIES INC., *Fire Resistance Directory*, 1981 Edition, Northbrook, IL, 1981.

PREVENTION OF INTERIOR SPREAD OF FIRE

Uncontrolled or rapid fire spread within a building is usually the result of a failure to incorporate suitable fire-protection features that can extinguish a fire, confine it to a predetermined area, or at least limit its rate of spread. The particular items covered in this chapter deal with construction features that influence the control of fire spread within buildings. Some of these may have overlapping fire-prevention or protection function because of the assumption that one or more of these features may not be in its design-intended condition and backup protection is needed for assurance of fire safety.

Protection of Vertical Openings

Hot gases generated by a fire will rise and vertical openings, such as elevator shafts, stairways, and other vertical shafts in a building, can act as flues. As heated gases and smoke rise from the fire area and fresh air is drawn into the fire area, the intensity of the original fire builds up while heated gases and fire are distributed throughout the upper floors. Fire records show that it is not uncommon for a fire originating in a basement to spread rapidly to the upper stories, resulting in greater loss of life or property in the upper portion of the building than in the area of its origin.

In the LaSalle (Chicago) and Winecoff (Atlanta) hotel fires in 1946, which resulted in heavy life losses, unprotected vertical openings were a major cause of fire spread. Unenclosed openings were also a significant factor in the spread of fire and resulting loss of life in an 11-story hotel in Tucson, Arizona, during late 1970. Modern building codes do not permit such deficiencies in design or construction.

Among the more important building code provisions for the control of fire spread are those that require vertical openings to be enclosed with noncombustible, fire-resistive walls or partitions. A fire-resistive stairway enclosure will not only give greater assurance of safe egress

for the occupants, but will also provide a relatively safe area for fire fighters. Most model codes require a fire-resistance rating of 2-hours for enclosure of exits in buildings four stories or more in height.* For buildings three stories or less in height, codes require a 1-hour fire-resistance rating for such enclosures. The enclosed stairway, including treads, risers, and stringers, should be of noncombustible construction but need not be fire-rated. This level of protection will provide a reasonable degree of safety against vertical fire spread in buildings. Code requirements for elevator shaft enclosures are the same as for stair shafts.

Enclosures that will prevent fire spread in other vertical shafts are equally important. Some codes permit a lower fire resistance for vertical shafts used for pipe chases, air ducts, and electrical conduits. However, since heat, smoke, or fire can travel upwards through such shafts just as readily as stairway or elevator shafts, and are likely to go undetected longer, permitting lower fire resistance for the enclosing walls is not recommended. Many vertical passageways such as those for kitchen exhaust ducts, telephone and electrical cable shafts, and air conditioning systems can be a source of fire. Because of such hazards, the enclosure must be able to contain a fire originating within the shaft as well as keep external fires out.

There are several notable exceptions to provisions for vertical openings. These include escalators, grand stairways and vertical openings in one- and two-family dwellings. Escalators pose a special problem with respect to controlling fire spread. Complete enclosure of the moving stairs is particularly objectionable in mercantile establishments because of the desire to maintain an open design. The risk of fire spread from story to story can be reduced, however, by measures intended to restrict the flow of hot gases through openings for moving stairs. These measures include automatically activated water curtains, venting systems, self-closing rolling shutters or enclosure of the upper end of each escalator.

Enclosure is usually not required for "monumental" stairs or "grand" stairways typified by those frequently seen in open multi-story lobbies of hotels, public buildings, theaters, restaurants, banks and office buildings. In these cases, an exception has been made if such stairs are in excess of the required minimum exit facilities and do not connect more than two floors.

*The Uniform Building Code currently requires the 2-hour enclosure for buildings five or more stories and 1 hour for buildings four stories or less.

Fire Walls or Area Separation Walls

Area limits established in building codes do not necessarily restrict the overall size of a building. Building code provisions require that a building be subdivided by fire walls or area separation walls into areas whose size is related to the severity of the fire hazard associated with the occupancy and the type of construction. Consequently, the aggregate floor area within exterior walls may result in a building considerably greater than that permitted as the basic area by the code. The fire-resistive requirements for fire walls or area separation walls should also be consistent with the fire load inherent for the occupancy and the type of construction. Where such walls separate more than one occupancy or type of construction, the fire-resistive requirements should be determined by the combination of occupancy and construction type representing the greatest total fire load.

In addition to the fire-resistive requirements for fire walls and area separation walls, other construction features are needed in order for the wall to act as a complete barrier against the spread of fire. Such walls should be continuous and extend through all floors up to the underside of noncombustible roof construction. If the roof construction is combustible, then the wall must continue through the roof to form a parapet. Parapets should extend at least 30 inches (762 mm) above the roof line and have fire resistance equal to the wall of which it is a part. This height is needed to minimize the possibility of exposure to the flames lapping over to construction on the other side of the wall. A parapet can also serve as protection for fire fighters from direct exposure to flames extending above a roof line.

Although fire walls or area separation walls may serve as occupancy separations, they are not synonymous. Fire walls are required when the building area exceeds the allowable area limitations for a particular construction type and occupancy. An occupancy separation is a fire barrier within a building that houses more than one occupancy class.

Fire Resistive Interior Walls and Partitions

Partitions are interior walls that divide a single building floor area into separate spaces. Unlike fire walls, they do not need to extend through floors and roof constructions.

Partitions on a single floor can provide protection against the spread of fire between occupied spaces within one occupancy and can assure a degree of safety for egress along corridors. It is a sound principle to require fire separation between tenancies in order to minimize the

possibility of fire spread from one tenant to the next on the same floor. Of greater importance is the use of walls or partitions to protect means of egress, such as stairs and corridors, and to keep them free of fire and smoke during evacuation. If a building contains different types of occupancies, the fire resistance established for a wall or partition is determined by the occupancy group that contains the highest fire load.

In multistory buildings, walls or partitions that separate tenants within the same occupancy group or those that form corridors should have at least a 1-hour fire-resistance rating. If walls or partitions are specifically designed to enclose vertical openings, fire-resistance ratings as high as two hours may be required.

Openings in Interior Walls or Partitions

Any opening in interior walls or partitions of fire-resistive construction creates a potential avenue for fire spread and, hence, their number and size must be limited. If an opening must be made in a fire-rated wall or partition, the opening must be equipped with a door, frame, and hardware which will retard the spread of fire and smoke for a period approximately equal to the fire resistance rating of the wall assembly in which it is located.

Protective devices for wall and partition openings are tested in accordance with Standard Methods of Fire Tests of Door Assemblies, ASTM E 152. While the requirements for time-temperature exposure in this method are the same as those in the standard fire test, ASTM E 119, tested assemblies are assigned a fire-protection rating, as distinguished from a fire-resistance rating, if they satisfy the conditions of acceptance within a given time period. The conditions of acceptance include the requirement that the door remain in place during exposure to the fire and a subsequent hose stream application and the door and frame not warp or shift within specified limits.

In 1970, a recommendation was added to the Standard for Fire Doors and Windows, NFPA No. 80, which provides that the temperature measured on the unexposed surface of doors used in stairwell enclosures shall not exceed 450F (232C) for a period of up to 30 minutes of fire exposure.

The reason given for adding this temperature limit was that the level of radiant heat imposed upon those using the stairway as a means of egress should be limited. The limit may be theoretically sound, but there is little if any evidence to prove that the temperature limit addresses any actual hazardous condition.

Fire opening protective devices for use in openings in various locations, the maximum allowable size of wired glass windows, and the fire protection rating required for each location are shown in Table 19.

Fire protection requirements for door openings are related to the function of the wall or partition in which they are located. In most cases, the fire protection rating of the door may be less than the fire resistance rating of the wall or partition. This difference recognizes that door openings normally represent a relatively small proportion of the overall wall or partition area. Where properly rated fire doors are installed, free to close and in regular use, there is little likelihood of combustibles being in contact with the door.

Fire walls should have no openings. However, from a practical standpoint, openings may be needed. To assure that a fire will not spread through a fire wall opening, most building codes require that two fire door assemblies be installed, one on each side of the opening. This

Table 19—Classification of Openings in Fire Resistive Walls and Partitions

Class	Location	Fire Protection Rating (hrs.)	Approved Wired Glass	
			Max. Dimension (in)	Max. Area (in ²)
A	Fire walls and walls separating fire areas	3	Not permitted	
B	Enclosures of vertical communications, e.g., stairways, elevator shafts and 2 hour partitions providing horizontal separation	1 or 1½	12	100
C	Corridors and room partitions	¾	54	1296
D	Exterior walls subject to severe fire exposure from outside	1½	Not permitted	
E	Exterior walls subject to moderate fire exposure from outside	¾	54	1296

added requirement is intended to provide for automatic door closing regardless of which side the fire originates. This arrangement also provides back-up in case one of the doors does not close as intended. Storage may accumulate on either or both sides of an unused doorway and doors on both sides of a wall will provide added protection against the spread of fire from one side to the other.

Interior Finish

In the previously referenced National Fire Protection Association study of the 500 representative fires where loss of life occurred, the second most frequently reported factor responsible for loss of life, following vertical fire spread, was combustible interior finishes used on ceilings or walls.

Fire spread, where hazardous types of finish materials have been used, can be so rapid that occupants may be overcome before they have a chance either to escape or be rescued.

Fires accounting for a great loss of life have focused attention on the need to differentiate between the kinds of finish materials as well as regulating these materials according to their hazard. Early regulations controlling the combustibility of interior finish prohibited the use of combustible materials in buildings classified as "fire proof" or fire-resistive construction. Yet combustible finish materials were permitted to be used in combustible structures. This approach overlooked the influence of combustible interior finish on life safety.

Building codes now regulate interior finish according to the building's occupancy and the location where it is used in the building, regardless of the type of construction.

There is greater hazard to life from highly combustible finish materials when used in assembly, institutional, and residential occupancies than in other occupancies. Use of a combustible finish material in a hospital, for example, creates a higher risk than the same material in an office building. In like manner, the hazard of a particular finish in an exitway presents a greater risk than its use in an isolated room.

The relative hazard of finish materials is determined by their surface burning characteristics, as measured by Standard Method of Test for Surface Burning Characteristics of Building Materials, ASTM E 84. This test method has been accepted as the standard by which surface burning characteristics of interior finish materials are compared in the United States and Canadian building regulations. The method described in ASTM E 84 evaluates the material's surface burning charac-

teristics by measuring the rate of flame travel along the horizontal surface of the material exposed from beneath to a standard fire. By comparing the rate of flame spread along the horizontal surface of a test sample with those obtained by similarly tested reference materials, a classification is assigned. The two reference materials, red oak and asbestos cement board, are assigned arbitrary flame spread classifications of 100 and 0, respectively. These points then provide a scale from which the rate of flame spread of different interior finish materials may be compared. For example, the flame travel on red oak, given a rating of 100, is 19½ feet (5.9 m) in 5½ minutes; a material on which fire will spread at twice this rate (19½ feet (5.9 m) in 2¾ minutes) is given a flame-spread classification of 200.

Building codes define limits for the allowable flame spread classification for interior finish materials in specific locations or occupancies with an upper limit on flame spread classification of 200 in any location. Within exits, the limits are between 25 and 75. The Life Safety Code, NFPA No. 101, includes a limit on smoke development in its interior finish requirements and defines three classes of interior finish which include limits for both flame spread classification and smoke development.

The test procedures of ASTM E 84 are used to obtain the ‘‘smoke developed’’ classification mentioned above. The value for this characteristic is obtained from a curve of light intensity readings versus time. The readings indicate the degree of light absorption and the numerical value of the smoke developed classification is based on a comparison of the areas under the curves obtained for the red oak, assigned a value of 100, and for the test material.

The significance of values derived from this test are questionable. Interior finish materials that burn slowly but emit a great deal of opaque smoke can be just as hazardous to life as materials that burn rapidly but give off a lesser amount of smoke or irritant gases. Correlations between opacity and toxicity have not yet been evaluated. An aggregate classification that would include both factors would seem desirable, but its development will be difficult because of the broad range of material properties. The 1979 edition of the Life Safety Code limits the allowable smoke development classification of interior finish but only because no other suitable test method has been widely recognized. Other test procedures to measure both the quantity and rate of smoke and fuel contribution under a range of heat intensities are now under development.

During exposure to heat many synthetic materials degrade and release highly toxic and corrosive gases. These materials have added a new dimension to building fire hazards. Rarely does a burning material produce only one toxicant. However, the effects of two or more toxic materials are not necessarily additive. The rate at which such products of combustion are formed is not necessarily uniform during a test exposure—let alone under uncontrolled conditions. It is therefore extremely difficult to devise a laboratory test that can identify and compare the behavior of a wide range of materials when exposed to a wide range of time-temperature curves. The Life Safety Code specifies that interior finish materials representing an unreasonable life hazard due to the character of the products of combustion may only be used with specific permission of the authority having jurisdiction.

Firestopping

During a fire, many of the concealed spaces within a building's construction can act as flues or ducts because of the draft created by hot gases. To minimize air flow to burning materials as well as the risk of fire spread within combustible spaces, firestopping within concealed spaces is essential. An opening within a construction assembly need not be large to be potentially dangerous. An opening no larger than the cross section of a piece of pipe or conduit is sufficient to permit fire-generated hot gases to move through and spread fire into another area.

Completely effective firestopping is extremely difficult to provide. The National Bureau of Standards Report BMS 92, in a discussion of firestopping in construction, states:

“Even with good fire fighting, fire and smoke are likely to be communicated through concealed spaces in the construction, the firestopping of which cannot be fully assured. Considering that the application of firestopping to prevent communication of fire through the concealed spaces in wood framing cannot be assured, it appears that a reasonable degree of safety in the higher buildings having such a framing is difficult to obtain. The increased safety with incombustible floor and other subdividing interior construction has been abundantly indicated by the fire record.”

In combustible construction, despite protection by fire-resistive ceilings or wall finishes, there is the danger of a fire originating behind the protective finish or of heated gases spreading in back of the finish and igniting combustible construction materials.

Fire tests conducted on protected wood joist floor and ceiling assemblies have resulted in temperatures in the plenum area high enough to

ignite the joists in less than one-half hour after the start of the test. During the course of fire exposure, the interior of a fire-rated combustible floor and ceiling assembly may not only ignite, but would, in all probability, continue to burn, even after the visible burning material has been extinguished. This is the prime reason for firestopping combustible wall, partition, floor, and roof constructions. By so doing, the spread of fire may be retarded, allowing more time for detection and suppression.

Where the floor and roof construction is made up of noncombustible materials, firestopping is usually unnecessary. In fact, firestops within noncombustible ceiling construction may prevent dispersal of heated gases and thus do more harm than good.

Firestops are essential, however, in walls and partitions at the floor levels in every type of building construction. They prevent fire, smoke, and hot gases from rising to the upper stories. Properly installed firestops, especially fabricated from noncombustible materials such as sheet steel, gypsum wallboard, plaster on metal or gypsum lath, or brick masonry, can effectively minimize flue action and the spread of fire and smoke. Ducts or conduits which penetrate firestops should be of materials that retain their shape during fire exposure. If they collapse or deform, openings can develop through which fire and heat can travel.

Ducts

Heating, ventilating, and air conditioning systems that employ air distribution ducts can act as a means of spreading heat, fire, and smoke to areas they serve, either through the ducts themselves or by the materials used for duct construction.

A number of serious fires have been directly attributed to the use of combustible materials in air duct system construction. Nonetheless, building codes and air conditioning system standards do permit ducts to be constructed of some combustible materials in portions of systems in most occupancies and in nearly all duct work in dwellings.

Smoke spreading through air duct systems has, in some instances, led to loss of life even where the fire itself was relatively small and caused little damage either to the building or its contents. The fire and smoke hazard is increased still further by combustible waste and dust that tends to accumulate in duct systems, and by oil or grease deposits on filters. Combustibles within ducts are not only the means by which a fire can spread through the system but may also be the origin of a fire. A

further hazard is the inaccessibility of duct interiors, making fire fighting difficult. For these reasons, it is highly desirable that ducts be constructed of steel or other noncombustible materials that will neither burn nor spread fire and smoke, and that can withstand the high temperatures characteristic of building fires.

Penetrations of Fire-Resistive Assemblies

In building codes, fire-resistive assemblies are recognized on the presumption that the field construction or installation conforms to the tested specimen and that the materials, their application and all dimensions will be the same as those tested. Therefore, any holes or other openings must be limited to the number, area, and distribution, the same as they were in the tested assembly.

An exception permits openings, that do not exceed a given percentage of the ceiling area, for electrical outlets or similar devices. However, such penetrations must not extend through the entire floor/ceiling or wall assembly.

Plumbing, air handling, electrical, communications, and other building service systems normally pass through fire-resistive assemblies. Since such penetrations are difficult to avoid, provisions must be made to prevent fire spread. For example, when air ducts pass through fire walls or fire-rated partitions, automatic fire doors or fire dampers are required by the provisions of most codes and by the Standard for the Installation of Air Conditioning and Ventilating Systems, NFPA No. 90A. Dampers may not be needed in every case where air ducts of limited size penetrate fire-resistive shaft enclosures or fire-resistive ceilings if test data and experience show that they are unnecessary.

If electrical and communication circuits other than those shown on the original building plans are added after construction is completed, it may be necessary to cut holes in fire-resistive floors or partitions for them to be installed. This method of installation is often called "poke-through construction" as the penetrations are usually made by punching or cutting holes in the floor or wall construction with little regard for workmanship or the fact that the fire safety of the occupants and structure may be compromised. The number and size of these penetrations can entirely nullify the intended fire resistance of the construction. Tests conducted in 1965 showed that the heat transmission end point of a 2-hour fire-resistant floor could be reached within six minutes if the floor was penetrated even by very limited size openings such as for electrical conduits. Even when the space around a conduit was filled

with noncombustible packing, the full 2-hour rating was not restored.

Building code requirements should clearly prohibit any breaching of fire protection unless the holes are made and later sealed in a manner that will sustain the required fire resistance.

High Rise Buildings

The possibility of fires and a major loss of life in “high rise” buildings has created concern among building code and fire fighting authorities because prompt evacuation, the traditional approach to achieving life safety from a building fire, may not be possible. Recognition of the extreme difficulty in providing prompt rescue and fire suppression in these structures has resulted in additional design criteria and building code requirements.

The incidence of fires and the loss of life in high rise buildings in terms of percent of those “exposed” to fire is low. It has been estimated that at the present rates, it would take 400 years for the number of fire deaths in high-rise buildings to equal the total deaths due to fire in one year in one- and two-family dwellings.

Emergency or not, large numbers of persons will be unable to leave high-rise buildings by means of stairways without undue delay. Tests conducted in Canada in 1969 indicated that periods as long as two hours and eleven minutes were required to evacuate a 50-story building, allowing one 44-inch (1.1 m) wide stairway for each 240 persons per floor. Although exiting time from a high-rise building might be improved by providing greater exit capacity (the NFPA Life Safety Code assumes a 44-inch stairway, 2-unit width, would be adequate for only 120 persons), complete evacuation by stairways cannot be considered as practical. It cannot be assumed that everyone in a high rise building is physically capable of descending 20, 30, or more flights of stairs. Further, the response of an undisciplined group of persons descending an unfamiliar enclosed stairway under emergency conditions cannot be presumed to be either orderly or safe.

Where buildings are erected to heights such that elevators are the only practical means of access to or egress from upper levels, the elevators and their controls must be able to function reliably under fire conditions. This requirement may be achievable only if facilities are provided throughout the building that will minimize the risk of spreading fire and smoke.

An alternate to complete building evacuation is the use of designated “areas of refuge” within the building. These areas may be provided by

dividing each floor into wholly separate sections to be used for immediate refuge from fire and smoke. Requirements that have been proposed for areas of refuge include separate means of exiting and separate air handling facilities, and separation of the refuge area from the rest of the floor by a fire-resistive partition and self-closing fire doors. Such an arrangement would provide a relatively safe base for orderly evacuation as well as a station from which fire fighting operations could be initiated. Areas of refuge might not be needed on every floor if safe access to them from other levels is provided.

If complete and rapid evacuation is not feasible, plans must be formulated to inform building occupants of actions to be taken other than leaving the burning structure. To do this an effective communications system is necessary. Systems have been designed that are capable of transmitting information concerning emergency situations and recommended actions to all or selected portions of a building.

Prior to the transmission of emergency information, however, the nature and location of the emergency condition must be determined and its seriousness evaluated with minimum delay. Response procedures must be preplanned and persons qualified to make decisions must be on duty.

A Chicago apartment house study indicated that the frequency of fires in 470 apartment buildings was one fire every 12 years. A sampling of fires in sprinklered office buildings in New York showed a similar frequency; about one fire per building every 10 years. To expect a highly sophisticated communication system to be properly and responsibly maintained and competently manned at all times when only used at extended intervals is an issue that deserves serious study.

A fire may not be discovered promptly. Even if it is, notification of the occupants of a building may be delayed because of lack of properly designated authority, lack of knowledge, or improper response on the part of those discovering the fire. The important point is that regardless of how sophisticated a protection system may be, life safety depends on intelligent and informed response to the many conditions that confront occupants singularly and collectively in the event of a fire. Fire incidence may be reduced and an alarm may be promptly sounded, but maximizing life safety ultimately depends on a rational response by those exposed to the situation.

Electrical power for emergency systems in a building is essential. Detection, notification and communication systems require a secondary source of electrical power for added reliability. Power for

emergency lighting in stairways and other critical locations is also essential. Pumps may be needed to provide water to the upper floors. Elevators and fans for air handling equipment should be capable of operating at all times. Requirements for installation of automatic sprinkler systems in high-rise buildings should also be considered with reference to the fire safety provisions that are already prescribed by building codes.

The interest in providing fire safety in high-rise buildings has expressed itself largely in the formulation of building code requirements in addition to those already in effect. These requirements have been based on the assumption that factors which result in fire can be predicted, and the effects of fire can be minimized in tall buildings by a combination of structural and operational safeguards. In contrast to this philosophy is the experience showing that protective or preventive factors were either absent, misused, or inoperative.

The conclusion to be drawn, therefore, is that proper design and maintainance of high-rise buildings may require greater recognition of the need for fire prevention as a matter of building operation policy, a matter not subject to building code regulations. Regulations can only attempt to provide compensation for inadequacies in fire prevention.

Buildings Without Windows

Windowless buildings have been designed and built where a controlled interior environment is needed or where the use of the wall space is especially important, such as in mercantile buildings. Such structures may present serious risks to the occupants in the event of fire. As in basements, the lack of ventilation and access may make even finding a fire very difficult.

One of the major concerns in a windowless building is the possibility that the electrical system may fail during a fire. Since this would likely result in almost total darkness, safe and orderly evacuation would be difficult to maintain and the possibility of panic would be very real. A secondary or auxiliary electrical generating system, capable of providing power to all exit lighting and emergency equipment, should be required in all inhabited windowless buildings.

In order to eliminate some of the problems that can arise from a fire in a windowless building, a special smoke exhaust system is required. Conventional air conditioning systems are usually insufficient because mechanical equipment is not designed to handle high temperature gases and the flow pattern for exhaust of smoke may not necessarily be

compatible with the arrangement of the return air system. Recommendations for the design and installation of systems that can effectively handle high temperature air and smoke are included in the Standard for the Installation of Air Conditioning and Ventilating Systems, NFPA No. 90A.

The windowless building, like any other, must provide adequate access from the outside of the building at all floor levels so that a fire can be fought effectively and safely. Modern codes contain requirements for access panels designed to facilitate fire-fighting operations in windowless buildings. In buildings where the number of wall openings is insufficient for fire-fighting needs or where the height of the building precludes the use of ladders to reach all floors, automatic fire-extinguishing equipment is required either in addition to or instead of access openings.

Basements and Cellars

Basement fires are relatively inaccessible and are apt to be unusually smoky because of restricted air supply. Firemen require special breathing apparatus to enter basements charged with fire and smoke, and this equipment does not give adequate protection against heat. These factors, plus the conditions brought about by the quantity and arrangement of materials usually kept in cellars and basements, make fire fighting in below-grade building areas extremely difficult and hazardous.

Under most circumstances the basement or cellar should be required to have a minimum of at least one-hour fire-resistive floor/ceiling construction and an automatic fire-extinguishing system. Only where the fire hazard and occupant content are low, such as in single family dwellings, should an exemption from this requirement be considered.

Furnace and Boiler Rooms

Fire records indicate that roughly ten percent of the total fire loss in the United States is attributable to faulty or malfunctioning heating equipment. Because most furnace and boiler rooms are located below grade, fires in these areas are relatively inaccessible and difficult to extinguish. Accordingly, the building codes typically require that such rooms be separated from the rest of the building by fire-resistive walls, floors and ceilings. Only dwellings are exempt from this requirement.

Chimneys and Vents

The requirements for chimneys and vents are determined by the exhaust temperatures of the heating equipment they serve. At one extreme, certain manufacturing processes require continually operating high-temperature furnaces. At the other end of the scale, heating appliances in residences use fuel intermittently and produce much lower flue-gas temperatures. To accommodate the wide range of equipment, four classifications of heating devices and appliances have been established in order to allow safe and efficient chimney design. These are designated as residential, low-heat, medium-heat or high-heat types. While they are not rigorously defined in terms of either temperatures or use cycle, numerous examples of each are given in the Standard for Chimneys, Fireplaces and Vents, NFPA No. 211.

Steel chimneys can be used with any type of heating appliance. Single wall chimneys, while permitted, must meet certain clearance requirements which effectively limit their use to industrial equipment. Ceramic liners are required for use with high- or medium-heat appliances as defined in the NFPA standard. For low-heat or residential type appliances, including fireplaces, factory-built all-metal chimneys have been developed. These may be single or multiple wall and may be insulated. The multiple systems are designed to circulate outside air in the annular spaces surrounding the entire length of the central vent. Cooler stack temperatures result and the low mass of the vent permits quick establishment of efficient stack operation for the removal of combustion products. Gas vents listed by Underwriters Laboratories Inc. are considered safe when installed in compliance with the listed conditions. General construction and installation requirements for chimneys, fireplaces, and vent systems are also included in NFPA No. 211. Most modern building codes make reference to this standard or contain requirements based on its provisions.

Automatic Fire-Extinguishing Systems

Automatic fire-extinguishing systems when properly designed, installed, and maintained, are an effective means of fire control. The type most widely used is the automatic sprinkler system using water as the extinguishing agent. Each system typically consists of an array of pipes that connect a source of water under pressure to discharge devices, known as sprinkler heads. The heads are located in a uniform pattern over the entire protected area and are designed such that, when heated to a predetermined temperature, a plug becomes dislodged by

the melting of a fusible link or by the rupture of a liquid-filled bulb. Thus opened, the head allows water to be discharged in a finely divided spray onto the area below. Heads are available that open at different specific temperatures, ranging from 135F to 500F (57C to 260C). The piping system connecting the individual heads is designed to provide a specific minimum discharge rate at the most distant sprinkler head. This rate is determined principally by the quantity and type of material that may be ignited. In large or tall buildings, more than one hydraulically independent system may be needed in order that pressures will not be excessive in the lower portions. Design criteria for automatic extinguishing systems that use water are included in the Standard for the Installation of Automatic Sprinklers, NFPA No. 13.

In situations where water either is ineffective as an extinguishing agent or may create a dangerous condition, other extinguishing agents such as carbon dioxide, special proprietary extinguishing agents, foam, or high-expansion foam should be used. In occupancies containing electronic equipment, water could cause as great a loss as a fire. Under these conditions carbon dioxide or another type of dry extinguishing agent would serve the purpose far better. Water is relatively ineffective on fires involving flammable liquids and can contribute to fire spread, while foams provide an effective extinguishing agent. The standards of the National Fire Protection Association and literature of manufacturers of equipment include design data for these special applications.

Recognition of Automatic Sprinklers as Alternate Protection—Building codes include a number of alternate provisions that are predicated on the installation of automatic fire-extinguishing systems. While there is little question as to the effectiveness of properly designed and functioning automatic sprinkler systems, they are not a general substitute for all fire protection requirements in building construction. Because any mechanical system is subject to failure or malfunction, any relaxation of minimum building code requirements, when automatic fire-extinguishing systems are installed, must be carefully weighed.

The most significant recognition that codes give to the installation of automatic fire-extinguishing systems is to permit an increase in allowable building areas. This increase is usually applied only where an automatic fire-extinguishing system is not required by other code provisions.

A number of building codes permit an increase of one story in building height when the entire building is protected by an automatic

extinguishing system not otherwise required. Here again, justification for the height increase is based on the favorable experience in buildings equipped with automatic extinguishing systems.

Some building codes will permit an increase in allowable exit capacity (the assumed number of persons passing through an exit per minute) or an increase in the travel distance to an exit when sprinklers are installed in a building. When increased exit capacity is allowed, it has the effect of reducing the total exit width. This, in turn, increases the time necessary for egress and may well cause overcrowding in the exitways. Extending the allowable travel distance to an exit does not create the danger of crowding at the exits as does the increase in design exit capacity. Travel times for those furthest from an exit will be increased, but with everyone moving at the same rate and with exits of a capacity to handle the number of persons, no crowding should occur. Thus, when an automatic fire extinguishing system is installed, code provisions allowing up to a 50 percent increase in travel distance to an exit are more reasonable than provisions for increasing individual exit capacities.

Some building codes stipulate that an automatic extinguishing system can serve as a substitute for a one-hour fire-resistive construction, or that fire-resistive requirements may be reduced by one hour when such a system is installed. The equivalence between fire-resistance ratings and automatic extinguishing systems is difficult to assess since the two protective methods are entirely dissimilar. Fire resistance provides static protection, not subject to radical change or malfunction, while an automatic fire extinguishing system is subject to both operational and maintenance problems.

Higher allowable flame-spread ratings of interior finish material have been permitted by some codes in buildings equipped with an automatic fire-extinguishing system. The liberalization of flame-spread requirements is permitted on the assumption that the extinguishing system reduces the possibility of fire spread. There is the danger, however, that fire may spread along the more combustible interior finish materials before the protective system is actuated. This could precipitate a failure of the extinguishing system to control the fire because of the larger area involved before the system's sprinkler heads are activated. The hazard to life from combustible interior finish materials is too well documented to permit the use of more hazardous materials simply because an automatic sprinkler system is installed.

Building codes generally require automatic extinguishing systems in

specific occupancies such as repair garages, large areas used for the manufacture, sale, or display of combustibles, stage areas, most types of hazardous occupancies and buildings or parts of buildings where suitable access is not provided such as basements, windowless buildings, and high-rise buildings.

Standpipes

Standpipes serve a useful and effective function in fighting fires. They make it possible to begin applying a water stream to a fire within a building without the delay that may occur from laying a long hose line up a stair tower.

Standpipes are classified as either wet or dry. Wet standpipes are charged with water. This type is usually equipped with preconnected hose and nozzle and may be placed in operation simply by laying out the hose and opening the valve. Dry standpipes are not water charged. They either have a special connection, provided for fire department use, or a remote device that can turn water on and charge the standpipe.

Modern building code practice requires all buildings over a certain height to be equipped with standpipes. Their number and size are determined by the building's height and floor area. In certain occupancies or where certain floor areas are greater than designated sizes, all standpipes must be wet regardless of the height of the building.

Standpipe regulations in the model building codes are based on the recommendations in Standards for Installation of Standpipe and Hose Systems, NFPA No. 14. The question of choosing between dry and wet standpipes, or of requiring both types, depends upon local conditions such as climate and available water supply.

Summary

The possible fire spread within a building can be minimized by design and construction that recognizes the interaction and interdependence of many factors.

Vertical spread can be minimized by suitable enclosure of floor openings and shafts and by firestopping walls or partitions at all floor levels. Horizontal spread can be controlled by subdividing areas with fire-resistive walls or partitions and, in combustible construction, by firestopping concealed ceiling areas.

The rate of fire spread is affected by the type of finish materials used for walls and ceilings. Adequate regulation of materials used for interior finish in assembly, educational, or institutional occupancies is

particularly important because of the increased life safety concerns associated with these occupancies.

Heating systems, chimneys and vents are a major source of fire and their installation must follow recognized safety principles. Even when not in use, air handling systems can significantly effect the spread of fire. The use of noncombustible materials in the duct work and the exclusion of other combustibles from duct interiors are an important safety consideration.

Automatic fire-extinguishing systems and standpipes are a valuable adjunct to the other fire protection measures in buildings because they aid in suppression of a fire almost immediately. Their use, however, should not be considered a total substitute for the generally accepted fire-safe design.

References

NATIONAL FIRE PROTECTION ASSOCIATION, "High Rise Building Fires and Fire Safety," Reprints of NFPA articles *SPP-18*, Boston, 1972.

—National Fire Protection Association, *Air Conditioning and Ventilation Systems (NFPA No. 90A)*.

—*Life Safety Code, (NFPA 101)*.

—*Chimneys, Fireplaces and Venting (NFPA No. 211)*.

—*Fire Doors and Windows (NFPA No. 80)*.

—*Smoke and Heat Venting Guide (NFPA No. 204)*.

—*Standard for the Installation of Sprinkler Systems (NFPA No. 13)*.

—*Standpipes and Hose Systems (NFPA No. 14)*.

STEVENS, R.E., "Maintaining Fire Resistance in Floor Assemblies," *Fire Journal*, Vol. 60, No. 2, p. 45, March 1966.

AMERICAN INSURANCE ASSOCIATION, *High Rise Buildings—A Review of the Problem*, New York, 1972.

GAGE-BABCOCK & ASSOCIATES, *Analysis of Proposals for High Rise Fire Safety*, City of Chicago, Westchester, IL, Dec. 3, 1961.

GENERAL SERVICES ADMINISTRATION, *Report of Public Building Services International Conference on Fire Safety in High-Rise Buildings*, Warrenton, VA, April 12-16, 1971.

GENERAL SERVICES ADMINISTRATION, *Proceedings: International Conference of Fire Safety in High-Rise Buildings*, Washington, D.C., Oct. 5, 1971.

HAGGERTY, J.R., "A New Look At Smoke Stop Partitions," *Fire Technology*, May 1970, Vol. 6, No. 2, pp. 111-122.

EXTERIOR WALLS AND ROOFS AND THE PREVENTION OF FIRE SPREAD

The prevention of the spread of fire between buildings and from story to story are the main fire protection functions of exterior walls of buildings. Zoning requirements which, for land use purposes, regulate the distance between buildings or other requirements affecting the size of windows and doors, may bring about inconsistencies with requirements for fire protection.

The traditional masonry exterior wall was generally considered to have a high degree of fire resistance and was usually specified in older codes as a means of preventing fire spread between buildings. Where the number and size of openings in the wall area were comparatively low, the heavy masonry wall usually provided adequate protection. With the development of lightweight, noncombustible, non-load bearing, weather-resisting wall panels and curtain walls, new code requirements and criteria were needed to adequately regulate these innovations.

Exterior Wall Requirements in the Model Building Codes

In the past, there has been very little agreement as to how to treat exterior walls in building codes, except to specify high fire-resistance requirements for both bearing and nonbearing walls in almost all types of construction and in all locations. Alternatively, some types of exterior walls were simply not permitted.

Although specific fire-resistance requirements for exterior walls were contained in the earlier codes, little or no attention was given to regulating the amount of openings for windows or doors. Such openings are the major source of fire spread between buildings. Codes now have regulations governing the amount of openings in exterior walls. However, few of these regulations have a rational or technical basis.

As mentioned previously, the fire protection functions of the exterior enclosure of a building are:

1. To prevent the spread of fire between buildings.
 2. To prevent the spread of fire from story to story.
- To meet these functions, building codes should regulate the exterior by:
1. Controlling the exposure to adjoining buildings by establishing minimum separation distances and limits on the size and number of openings.
 2. Regulating the vertical spacing of openings in the exterior enclosure to prevent ignition of combustibles in adjacent stories.
 3. Requiring the appropriate fire resistance of the exterior wall.

Thermal Radiation and Building Separation

Fire spread between the exterior of buildings can result from the convection of hot gases, airborne sparks and burning embers, or thermal radiation. While the spread of fire by convection is limited to a very few feet from a building, and flying brands can result in fires at considerable distances from the burning building, the dominant means by which fire is spread to adjacent structures is by thermal radiation.

A building may be protected from the thermal radiation of a burning building by a fire-resistive barrier which will prevent passage of radiated heat or by providing sufficient space between the buildings to limit the radiation intensity at the exposed building's exterior below that which would ignite combustibles in or on the building.

To provide protection to another building from fire exposure, the exposing building must have an adequate fire resistive wall without openings when on or near the property line. It will need little or no fire resistance when located at a sufficient distance from the other building. The wall may also have an increasing amount of openings as the separation distance increases. Only recently have criteria been established to regulate the extent of openings as a function of horizontal separation to prevent fire spread by radiant heat.

Much of the research on the measurement and development of techniques for calculating thermal radiation hazards between buildings was done in Japan, Great Britain and Canada. The exterior wall and separation requirements in codes in Canada, Great Britain and other countries have been derived from that work. The basis for these requirements were derived from fundamental principles of heat transfer.

The intensity of radiant energy at any point depends on the temperature of the fire, the distance from the heat source and the apparent size of the radiating fire as seen from the exposed location. The thermal

radiation intensity received from a radiating surface varies as the fourth power of the absolute temperature of the heat source. Thus, radiant energy per unit area of a fire at 1000 F (538 C) is about one-third that of a fire at 1500 F (816 C) and about one-eighth that of a fire at 2000 F (1093 C). The temperature attained in most well-ventilated building fires has been determined to be about 1800 F (982 C) in low hazard occupancies and 2200 F (1204 C) or over in moderate and high hazard occupancies.

Also, the intensity of radiant energy at any point on an exposed surface decreases with increasing distance from the heat source. The decrease is inversely proportional to the square of the distance from the source. This relationship is shown schematically in Figure 30. The size of the radiating source similarly affects the intensity of radiation received on an exposed surface. Thus, an increase in the size of the

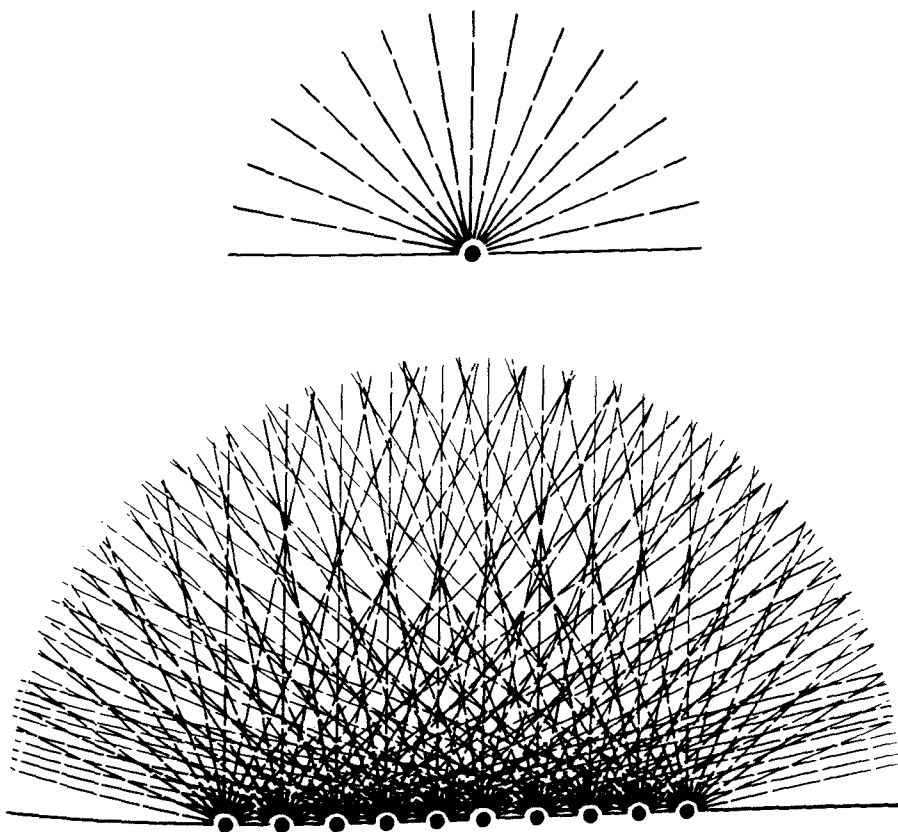

Figure 30. Because radiation scatters, intensity varies with the size and shape of the radiator and decreases with increasing distance from the heat source.

radiator will result in an increase of radiation received at a point. However, because of a greater average distance, radiation intensity at a point facing a fully developed fire in a long, low building or a tall narrow building will be less than from a more nearly square-sided building. This is illustrated in Figure 31.

These factors—temperature, distance and size of radiating surface—determine the level of radiation intensity received at any point on an exposed building. To offset these factors, measures must be taken to insure that the level of radiation does not exceed an intensity that will cause ignition of combustible materials on the exterior or interior of an exposed building.

Where exterior walls are noncombustible, the critical parts of the exposed building are the doors and windows. Radiated heat will penetrate windows and, although glass will reduce radiation intensity by about one-half, experience indicates that any allowance should not be considered as the glass may break or a door may be left open. Accordingly, the combustible contents of rooms, including draperies, should be considered as directly exposed to a fire. Therefore, radiation intensity at the exposed building face must be limited to a level that will not cause combustibles, either within or on the exterior of a building, to be

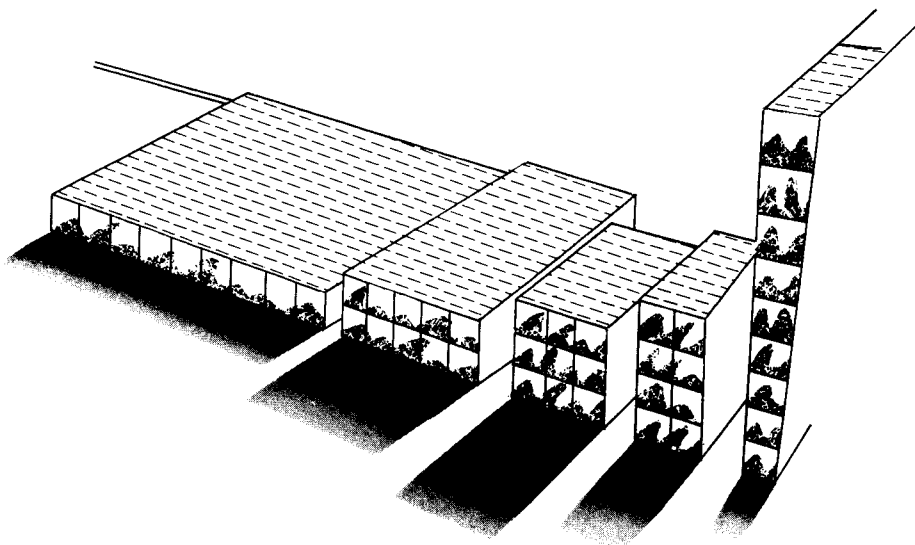

Figure 31. The effect of shape of exposing building face on distance separation. The five buildings have the same area of building face. The greater radiation intensity at a fixed distance for the more nearly square radiating wall is evident.

ignited by the radiation from a fire in an adjacent building.

The intensity of radiant energy necessary to cause pilot ignition of unpainted oven-dried wood has been determined to be about 0.3 calories/sq.cm./sec. Below this level, most cellulosic materials will not ignite from radiant energy. While there are other factors that may affect the critical intensity, it has been generally accepted in establishing horizontal separation requirements between buildings that the level of radiation on an exposed building surface should not exceed 0.3 calories/sq.cm./sec.

Minimum Separation Distances and Limits on Unprotected Openings

Knowing the factors influencing the radiation intensity, the minimum safe distances and the size or location of openings in an exterior wall can be calculated. The procedure itself is quite involved and does not lend itself well to formulation of a simply stated building code requirement. For practical purposes, it is easier to derive a set of tables which contain limits for the allowable area of unprotected openings in exterior walls for different areas of exposed building faces and separation distances. Both the British and Canadian codes make use of such tables to regulate the allowances for unprotected openings at separation distances.

Tables in codes serve to simplify regulation and enforcement. However, the direct calculation procedure should also be acceptable.

In 1979, the National Research Council of Canada published a simple approximation method for determining separation distances and developed a program for a programmable hand calculator which makes it possible to do the basic calculations rapidly and accurately. The following parameters are involved in the calculation method (Figure 32):

- The dimensions of the exposing building face, or a portion thereof, if the building is divided into fire resistive compartments, height (H) and width (W).
- Distance between the exposed building and the flame front, which is considered to be six feet in front of the exposing building face (D).
- Configuration factor, which is a dimensionless quantity derived from the geometry of the radiating surface and its position relative to an exposed element (F)
- Area of unprotected openings in the exposing building face (A).

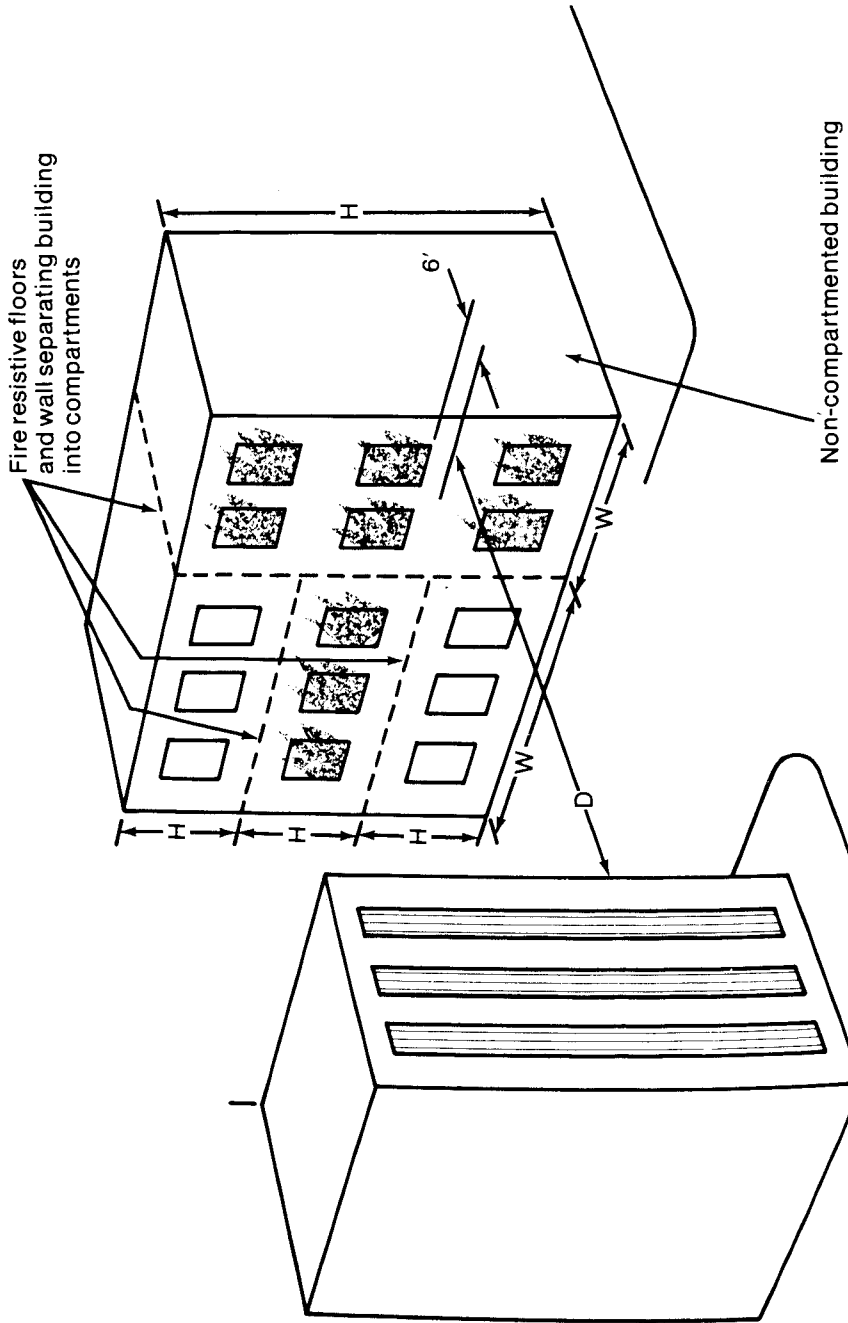

Figure 32. Dimensions for determining spatial separation between structures.

Tables 20A and 20B, "Maximum Recommended Percent of Unprotected Openings in Exterior Walls," were prepared using this simplified program and have been recommended to CABO by the Board for the Coordination of the Model Codes. In general they agree with the tables in the National Building Code of Canada but do not include values for the variable ratios of height to width of the exposing building face as in the Canadian code.

In the tables, the area of unprotected openings in the exposing building face is the aggregate of the openings expressed as a percentage of the total area. The area of the exposing building face is considered to be the total area of the exterior wall facing in one direction. However, if the building is divided by fire separations, i.e., fire resistive walls, partitions or floor assemblies, the area of the building face is considered to be the area of the exterior wall of each fire compartment.

The fire separation ratings should be at least that required for the floor assembly of the compartment, but not less than 1-hour fire resistance in low hazard occupancies and 2-hours in moderate and high hazard occupancies.

Where the exterior wall of a building includes offsets, the horizontal separation distance is measured from a vertical plane located at the furthest extension of the exterior wall in the direction of the exposed building. The areas of unprotected openings are assumed to project on to that plane.

Because glass has the effect of reducing radiation from the burning building by about one-half, when it remains in place, the National Building Code of Canada allows double the area of openings where wired glass in fixed steel frames is used. This code also permits the area of openings to be doubled if the building is sprinklered.

The wall itself may also contribute to the radiant heat flux depending on the temperature on its exterior surface during a fire. The National Building Code of Canada assumes that the radiant energy from walls having a temperature of 250 F (121 C) or less is negligible but if the temperature of the exterior face is higher than 250 F (121 C), then radiant energy from the wall surface is included in the calculations for determining allowable area of openings. Thus, an exterior wall assembly which does not meet the standard 250 F (121 C) temperature requirement on the unexposed surface can be used provided a correction is made for the radiation from the wall surface. This correction is done by adding an "equivalent opening factor" to the

Table 20A
Maximum Area of Unprotected Openings in Exterior Walls^{1,5}
(Percentage of Exposing Building Face)
for Group A, B, E, F2, I, R, S2 Occupancies

Max. Area ⁴ of Exposing Building Face Sq. Ft.	HORIZONTAL SEPARATION																		
	0	3	4	5	6	7	8	9	10	15	20	25	30	35	40	45			
100	0	0	9	12	18	25	33	43	55	100									
150	0	0	8	11	15	20	25	32	40	96	100								
200	0	0	8	10	13	17	21	27	33	75	100								
250	0	0	8	9	12	15	19	23	28	62	100								
300	0	0	8	9	11	14	17	21	25	54	97	100							
400	0	0	7	9	10	12	15	18	21	43	75	100							
500	0	0	7	8	10	11	14	16	19	36	62	97	100						
600	0	0	7	8	9	11	13	15	17	32	54	83	100						
700	0	0	7	8	9	10	12	14	16	29	48	73	100						
800	0	0	7	8	9	10	11	13	15	27	43	65	92	100					
900	0	0	7	8	9	10	11	12	14	25	39	59	83	100					
1,000	0	0	7	8	8	9	11	12	13	23	37	54	76	100					
1,500	0	0	7	7	8	9	10	11	12	18	28	40	54	72	92	100			
2,000	0	0	7	7	8	8	9	10	11	16	23	32	43	57	72	89			
2,500	0	0	7	7	8	8	9	9	10	14	20	28	37	47	60	74			
3,500	0	0	7	7	7	8	8	9	9	13	17	23	29	37	46	56			
5,000	0	0	7	7	7	8	8	8	9	11	14	19	23	29	35	42			
10,000	0	0	7	7	7	7	7	8	8	9	11	13	16	19	22	26			
20,000	0	0	7	7	7	7	7	7	7	8	9	11	12	14	16	18			

Table from BCMC Report to CABO November 18, 1980 — Reprinted with approval by Building Officials and Code Administration, International, Inc., Homewood, Illinois. Copyright 1980.

DISTANCE (FEET)^{2,3}

50	55	60	70	80	90	100	110	120	130	140	150	160	170	180	190	200	210	220	
100																			
90	100																		
67	80	93	100																
50	59	69	91	100															
30	35	40	51	64	78	95	100												
20	22	25	31	37	45	53	62	72	83	94	100								

Table 20B
Maximum Area of Unprotected Openings in Exterior Walls^{1.5}
(Percentage of Exposing Building Face)
for Group H, F1, M, S1 Occupancies

Max. Area ⁴ of Exposing Building Face Sq. Ft.	HORIZONTAL SEPARATION															
	0	3	4	5	6	7	8	9	10	15	20	25	30	35	40	45
100	0	0	4	6	9	12	17	21	27	69	100					
150	0	0	4	5	7	10	13	16	20	48	91	100				
200	0	0	4	5	7	8	11	13	16	38	70	100				
250	0	0	4	5	6	8	9	12	14	31	57	91	100			
300	0	0	4	5	6	7	9	10	12	27	48	77	100			
400	0	0	4	4	5	6	7	9	11	21	38	59	86	100		
500	0	0	4	4	5	6	7	8	9	18	31	48	70	96	100	
600	0	0	4	4	5	5	6	7	8	16	27	41	59	81	100	
700	0	0	4	4	5	5	6	7	8	14	24	36	52	70	92	100
800	0	0	4	4	4	5	6	7	7	13	22	32	46	62	81	100
900	0	0	4	4	4	5	5	6	7	12	20	29	42	56	73	92
1,000	0	0	4	4	4	5	5	6	7	12	18	27	38	51	66	84
1,500	0	0	4	4	4	4	5	5	6	9	14	20	27	36	46	58
2,000	0	0	4	4	4	4	4	5	5	8	12	16	22	28	36	45
2,500	0	0	4	4	4	4	4	5	5	7	10	14	18	24	30	37
3,500	0	0	4	4	4	4	4	4	5	6	9	11	15	18	23	28
5,000	0	0	4	4	4	4	4	4	4	6	7	9	12	14	18	21
10,000	0	0	4	4	4	4	4	4	4	5	6	7	8	10	11	13
20,000	0	0	4	4	4	4	4	4	4	4	5	5	6	7	8	9

Table from BCMC Report to CABO November 18, 1980— Reprinted with approval by Building Officials and Code Administration International, Inc., Homewood, Illinois. Copyright 1980.

DISTANCE (FEET)^{2,3}

50	55	60	70	80	90	100	110	120	130	140	150	160	170	180	190	200	210	220	
100																			
100																			
71	85	100																	
55	65	77	100																
45	54	63	85	100															
34	40	47	62	80	100														
25	30	34	45	58	73	89	100												
15	17	20	25	32	39	47	56	66	77	89	100								
10	11	12	15	19	22	26	31	36	41	47	53	60	67	75	83	91	100		

Notes to Tables 20A & 20B: Spatial Separation and Exposure Protection of Buildings

- 1) The area of unprotected openings in exterior walls required to have fire rating shall not exceed that set forth in Tables 20A and 20B. The area of unprotected openings in an exposing building face shall be the aggregate of unprotected openings expressed as a percentage of the area of the exposing building face.
- 2) Horizontal separation means a permanent open space between the building wall under consideration and the lot line or the center of a facing street, alley, or public place measured at right angles to the building face. Where two or more buildings are located on the same property the horizontal separation of the building wall under consideration shall be measured from an imaginary line drawn at a distance from the facing wall equal to the horizontal separation applicable for that wall.

Where the exterior wall of a building is an irregular shape, the horizontal separation distance shall be determined by measuring from a vertical plane located so that no portion of the exterior wall of the building is between such vertical plane and the line to which the horizontal separation is measured. In such cases the area of unprotected openings shall be determined from the projection onto this plane of the unprotected openings occurring in the exterior wall.

- 3) Where the fire fighting facilities or protective wetting facilities are not available within 10 minutes of an alarm being received the limiting distance shall be doubled.
(The requirements of this Section are aimed at combating fire spread by thermal radiation provided adequate fire fighting is envisioned.)
- 4) The area of an exposing building face shall be calculated as the total area of exterior wall facing in one direction on any side of a building measured from the finished ground level to the uppermost ceiling, except that where a building is divided by fire separations into fire compartments, the area of exposing building face may be calculated for each fire compartment provided such fire separations:
 - (a) in low hazard occupancies have a fire resistance rating at least equal to that required for the floor assembly, but not less than 1 hr.
 - (b) in Moderate hazard occupancies have a fire resistance rating of at least 2 hrs., and
 - (c) in High hazard occupancies have a fire resistance rating of at least 3 hrs.
- 5) The area of unprotected openings in any exposing building face may double where the building is sprinklered, the openings are glazed with wired glass in fixed steel frames, or the opening is protected with a $\frac{3}{4}$ hour listed device.

actual opening area. The factor can only be applied to tested assemblies where the unexposed surface temperatures have been measured. This is done by assuming the equivalent opening factor, F_{eo} , is somewhat less than 1.

The corrected area of unprotected openings is determined by the following formula:

$$A_c = A + (A_f \times F_{eo})$$

Where A_c = Corrected area of unprotected openings including actual and equivalent openings.

A = Actual area of unprotected openings.

A_f = Area of exterior surface of exposing building, exclusive of openings on which the temperature limitation of the standard test has been exceeded.

F_{eo} = An "equivalent opening factor" derived from:

$$F_{eo} = \frac{(T_u + 460)^4}{(T_c + 460)^4}$$

Where T_u = Average temperature (F) of the unexposed wall surface at the time the required fire resistance rating is reached.

T_c = Temperature of compartment based on standard fire test temperatures:

1700F for a 1 hr. rating

1850F for a 2 hr. rating

1925F for a 3 hr. rating

The effect of adding the equivalent opening factor to the area of openings in an exterior wall is to increase the required separation distance. For example, consider a building with an exterior wall which after a 1-hour standard fire test has an exterior surface temperature of 890 F. If the building has 2000 square feet of wall area and 800 square feet of openings the equivalent opening factor, F_{eo} , can be determined:

$$F_{eo} = \frac{(890 + 460)^4}{(1700 + 460)^4} = \frac{1350^4}{2160^4} = .152$$

and the corrected area of unprotected openings becomes:

$$A_c = 800 \text{ sq. ft.} + (2000 \text{ sq. ft.} \times .152)$$

$$A_c = 800 \text{ sq. ft.} + 304 \text{ sq. ft.}$$

$$A_c = 1104 \text{ sq. ft.}$$

Protection of Openings in Exterior Walls

Where window openings are exposed to a possible fire from an adjoining roof or in an adjoining face of the same building, typical code practice requires that the openings be protected by using wired glass in fixed steel frames or by other acceptable opening protectives. It is also common practice to require protection of openings where they are located close to property lines or other buildings. The requirements for protection of openings in exterior walls in the model codes are not uniform. Generally, they require protection of openings when the building face is less than 15 feet (4.5 m) from a lot line or centerline of a street. Most codes exempt one- and two-family dwellings, churches and open parking structures from the opening protection requirement.

Fire Resistance Requirements for Non-Load Bearing Exterior Walls

Non-load bearing walls, sometimes called panel or curtain walls, are usually one story in height and supported by the structural frame at each floor. They are generally designed to resist wind and other horizontal loads. During a fire they are expected to remain in place for the period of expected exposure from an interior fire. Where such walls are located near the property line or close to other building walls, the required fire resistance should be related to the fire load of the occupancy. As separation between buildings increases the fire resistance can be reduced. Generally, codes permit unprotected noncombustible walls at separation distances of 30 feet (9 m) or more. Obviously, where the code allows 100 percent unprotected openings in the exterior wall, the wall would be permitted to be of unprotected construction. However, where limitations on the amount of unprotected openings are necessary, a degree of fire resistance for the exterior wall is specified. The fire resistance should be related to the occupancy fire load and also to some extent the percentage of openings permitted. That procedure is used in the National Building Code of Canada.

The fire resistance requirements in the National Building Code of Canada are as follows:

In low fire load occupancies

1. Where less than ten percent of the wall area is permitted to have unprotected openings, the wall shall be of noncombustible construction having a fire resistance rating of at least 1-hour.

2. Where more than ten percent but less than 25 percent of the wall area is permitted to have unprotected openings, the wall shall have a fire resistance rating of at least 1-hour and shall be encased in noncombustible material or cladding.
3. Where more than 25 percent but less than 100 percent of the wall area is permitted to have unprotected openings, the wall shall have at least $\frac{3}{4}$ -hour fire resistance.

The same percentage requirements would apply to moderate hazard occupancies but the fire resistance requirements are increased to 2-hours and 1-hour, respectively.

An exception to the fire-resistance requirement is allowed for factory-industrial low hazard buildings. For one story buildings housing this occupancy, the exterior nonbearing walls may be of noncombustible construction without a fire resistance rating at a separation distance of ten feet (3 m) or more. Also, exemptions are made for one and two family dwellings and for open parking structures.

Fire Resistance Requirements for Load Bearing Exterior Walls

Exterior or interior walls that support structural loads are considered bearing walls and should have the same fire resistance requirements specified by the code for other load bearing members. In no case, however, should the load bearing wall have less fire resistance than that required for a non-load bearing wall in the same location.

Load bearing walls when exposed to fire are subjected to unusual stresses that are not necessarily developed in fire tests of walls of limited size test specimens. Because of differential expansion of the materials in the wall when heated on one side, the construction may deflect laterally during a fire and may become unstable and collapse. Many codes require greater thickness of material than indicated by test or structural strength to assure stability under fire conditions. Well-located cross walls or pilasters will also reduce possible collapse due to heat expansion.

Recommended fire resistance requirements for load bearing and non-load bearing walls have been developed by the Board for the Coordination of the Model Codes and are shown in Table 21.

Party Walls, Fire Walls and Parapets

A party wall is a wall on a common property line used or adapted for joint service between two adjacent building areas. In addition to

Table 21

Fire Resistance Requirements for Exterior Walls (Hrs.)

Horizontal Separation Distance & Hazard of Occupancy (1)		Noncombustible Wall Materials							Combustible Wall Materials	
		Type I		Type II		Type III		Type IV	Type V	
		332	222	111	100	211	200	2HH	111	100
Interior & Exterior Exposure (2)	0-5'									
	Bearing									
	Low	3	2	1	1	2	2	2	1	1
	Moderate	3	2	2	2	2	2	2	2	2
	High	3	3	3	3	3	3	3	(NP)	(NP)
	Non Load Bearing									
	Low	1	1	1	1	1	1	1	1	1
Moderate	2	2	2	2	2	2	2	2	2	
High	3	3	3	3	3	3	3	3	3	
Interior Exposure (2)	Over 5-10'									
	Bearing									
	Low	3	2	1	1	2	2	2	1	1(3)
	Moderate	3	2	1	1	2	2	2	1	1
	High	3	2	2	2	2	2	2	2	2
	Non Load Bearing									
	Low	1	1	1	1	1	1	1	1	1
Moderate	1	1	1	1	1	1	1	1	1	
High	2	2	2	2	2	2	2	2	2	
Interior Exposure (2)	Over 10-30'									
	Bearing									
	Low	3	2	1	0	2	2	2	1	0
	Moderate	3	2	1	0	2	2	2	1	0
	High	3	2	1	1	2	2	2	1	1
	Non Load Bearing									
	Low	1	1	1	0	1	1	1	1	0
Moderate	1	1	1	0	1	1	1	1	0	
High	2	2	1	1	1	1	1	1	1	
Interior Exposure (2)	Over 30'									
	Bearing									
	Low	3	2	1	0	2	2	2	1	0
	Moderate	3	2	1	0	2	2	2	1	0
	High	3	2	1	1	2	2	2	1	1
	Non Load Bearing									
	Low	0	0	0	0	0	0	0	0	0
Moderate	0	0	0	0	0	0	0	0	0	
High	1	1	1	1	1	1	1	1	1	

(NP) = NOT PERMITTED

Table from BCMA report to CABO November 18, 1980. Reprinted with approval by Building Officials and Code Administrators International, Inc., Homewood, Illinois, Copyright 1980.

Notes to Table 21: Fire Resistance Requirements for Exterior Walls

1) Hazard of Occupancy

- Low—“A” Assembly
- “B” Business
- “E” Educational
- “F-2” Factory-Industrial-Low
- “I” Institutional
- “R” Residential
- “S-2” Storage-Low

- Moderate—“F-1” Factory Industrial-Moderate
- “M” Mercantile
- “S-1” Storage-Moderate

- High—“H” Hazardous

2) The fire resistance requirements for exterior walls with 5 feet or less horizontal separation shall be based upon both interior and exterior fire exposure. The fire resistance requirements for exterior walls with more than 5 feet horizontal separation shall be based upon interior fire exposure only. The limitation on rise of temperature on the unexposed surface of the wall as required by the standard fire test method shall not apply provided a correction is made to include the radiation from the unexposed wall surface in the area of unprotected openings using an equivalent opening factor. (See page 183). Where protected openings are provided, the radiation from the unexposed surface of the protective device shall also be taken into consideration when the unexposed surface temperature exceeds that allowed for walls of the same fire resistance rating.

3) Fire resistance is not required for exterior walls of one- and two-family dwelling units with more than 5 feet horizontal separation except where one dwelling unit is located above another.

sharing the joint structural function between building areas, the wall is intended to act as a positive fire separation.

Fire walls or area separation walls, by design, divide a building into two or more sections so that each section may be considered as a separate building.

To achieve this separation, party and fire walls must be of noncombustible construction and provide sufficient fire resistance from either side to prevent the passage of fire even in the event of complete burn out on either side of the wall. The fire resistance required by codes is generally from 2- to 4-hours. Fire and party walls must extend continuously from the ground through all stories and through the roof unless the roof construction is noncombustible. In buildings of noncombustible construction, the wall may be supported on the structural frame provided the frame is fire protected and has fire resistance at least equal to that required for the wall.

A parapet wall of adequate height will prevent fire from spreading from roof to roof and may also act as a shield for firemen while fighting fires in adjoining buildings. Parapets are usually required to be at least 30 inches (762 mm) in height.

Vertical Spread of Fire

When windows are located above one another or when the exterior of the building is of combustible construction, it is possible for fire to spread from story to story by flames issuing from the windows below and igniting the combustibles in the room above. Some building codes regulate this hazard by requirements for minimum separation between these openings when directly above one another. The separation requirements usually specify a fire resistive wall of a certain height, two to three feet (.6 to .9 m), or a horizontal projection of at least two feet (.6 m).

To verify the adequacy of the separation requirements, the Joint Fire Research Organization of Great Britain conducted an investigation, first with models, and later with a larger scale four-story building constructed for the test. The tests showed that the fire resistance requirements for exterior walls were extremely conservative. It was concluded that ignition of combustible materials and furniture in rooms immediately above a fire would not occur through the exterior for as long as 15 minutes even when the wall panel had no fire resistance. More important, however, was the finding that the British code provisions calling for vertical separation of two feet (.6 m) above

the floor in between windows in succeeding stories did not prevent ignition of combustible materials located near the windows in the story above a fire. Likewise, the two-foot (.6 m) horizontal projection or balcony which was thought to work as a deflector of flames from fire below was found to be ineffective. The assumed and actual effect of the wall with respect to deflecting flames were found to be quite different, as illustrated in Figures 33 and 34.

Within the conditions of the tests a vertical separation of three feet (.9 m) with two feet (.6 m) being above the floor level or the horizontal projection alternate both appear to be inadequate in preventing the spread of fire from story to story. The separations required to give the needed protection have not been determined. A reasonable consideration, however, would be to extend the wall panel up at least three feet

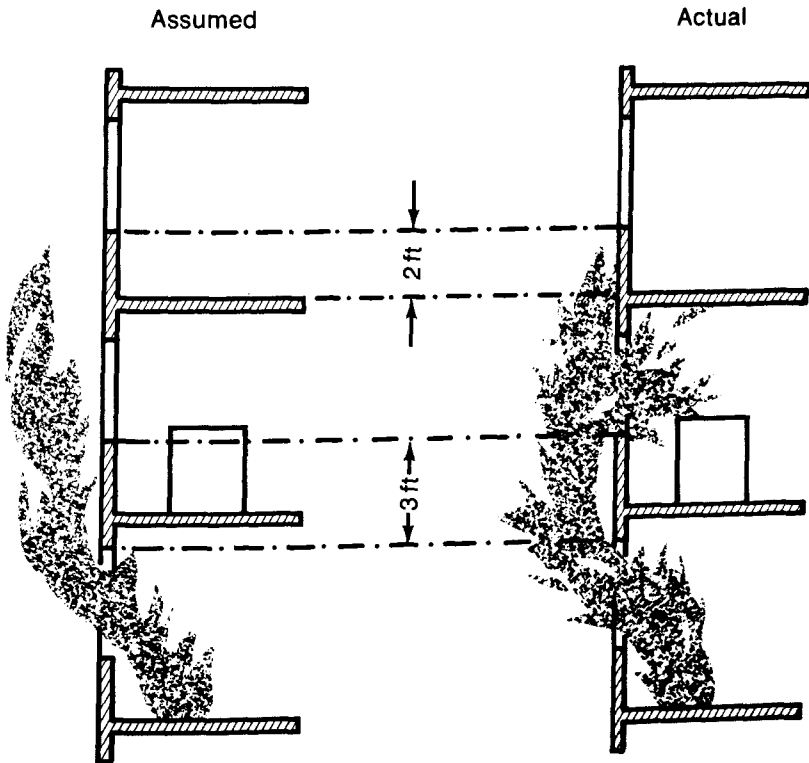

Figure 33. Assumed and actual shape of flames projecting from windows with vertical separation of openings.

(.9 m) above the floor, thereby shielding most furniture from direct exposure to flames from a fire below.

The tests also illustrated that for buildings not exposed by other structures there was very little need for the exterior walls, if of suitable construction, to have fire resistance ratings in order to prevent fire spread up the exterior of the building. Design details should, however, insure that the panels will stay in place during a fire.

While the investigation results indicated that solid wood combustible exterior cladding $\frac{3}{8}$ inches (9.5 mm) or more in thickness introduced little hazard for the height of the walls tested, other types of combustible materials including plastic laminates can cause a rapid and extensive spread of fire on the exterior wall. This is particularly the case where the cladding materials are continuous.

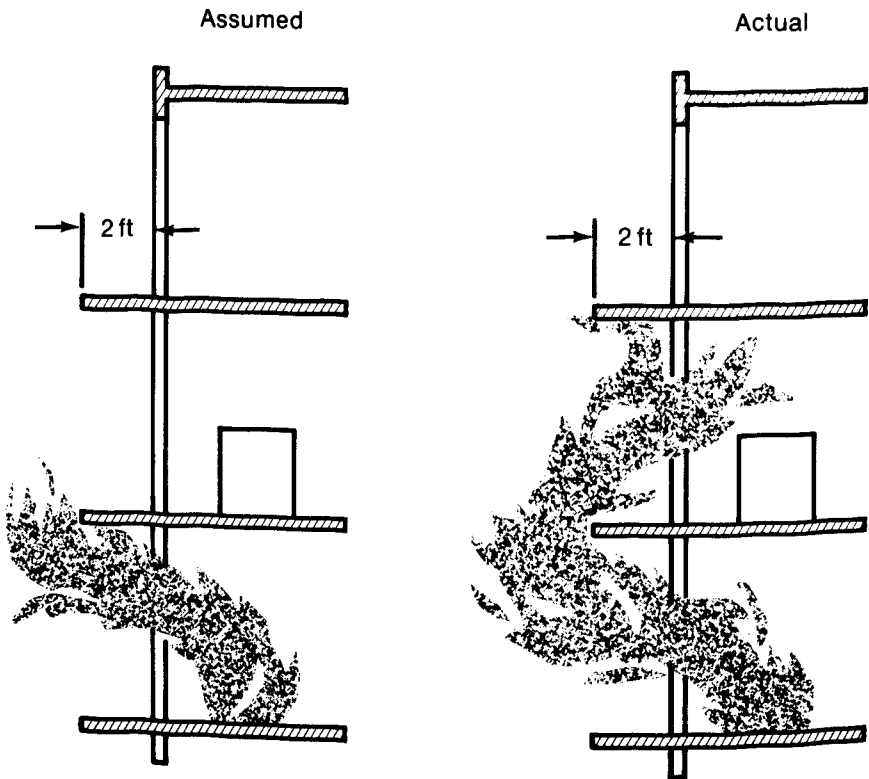

Figure 34. Assumed and actual shape of flames projecting from windows with horizontal projections between openings.

Roof Coverings

NFPA fire records show that combustible roof coverings have contributed significantly to the spread of fire in many conflagrations. Losses in millions of dollars have resulted from fires spread by wind-blown flaming brands from burning roofs lodging on other combustible roof surfaces.

Customarily, building codes restrict the use of roof coverings to those types that are effective against fire exposure and that resist the hazard of flying brands. Thus, the use of untreated wood shingles is usually prohibited or severely restricted by building regulations in the United States.

The National Fire Protection Association has recognized the hazards of roof coverings since its inception. In 1910 the Association developed roofing classifications based upon the relative fire-retardant properties of roofing materials. Since that time, classification of roofing materials has been established by Underwriters Laboratories Inc., and their present classifications are incorporated by reference in NFPA Standards and most building codes.

When the National Fire Protection Association developed the roof-covering classifications, it also adopted the position that wood-shingle roofing should not be used to cover any roof on any type of buildings in any locality. This policy has been endorsed by the International Association of Fire Chiefs and others. Building codes in many cities prohibit the use of wood-shingle roof covering for new buildings. As a result, the frequency of conflagrations from fires started by sparks on roofs of wood shingles has been substantially reduced.

Summary

A major design objective of exterior walls of a building is the containment of a fire, first within the building, then to a portion of that building. Openings must be protected or restricted in size and number to limit the level of radiant heat that could impinge on adjacent structures. Procedures are available that allow calculation of the percent of openings permissible in an exterior wall that would not result in dangerous exposure conditions. The exposure is a function of fire temperatures, the total area of openings or other radiating surfaces in the exterior, and the distance to exposed construction.

Fire resistance requirements for non-loadbearing exterior walls are based on the fire load of the building occupancy and the distance of the wall to a property line. These same factors apply to load bearing

exterior walls and to interior walls, but additional design requirements are necessary to assure stability of these walls during a fire.

It has been observed that preventing the spread of fire from floor to floor through window openings may require greater vertical distance between openings than many codes now specify and that the distances above a floor line may be more critical than the total distance.

Combustible roof coverings have been a common factor in nearly all major conflagrations. Roof covering materials should be such as to minimize or prevent the generation of flying brands as well as resist ignition by such flying brands.

References

BEVAN, R.C., AND WEBSTER, G.T., "Radiation from Building Fires," *Technical Paper No. 5*, Department of Scientific and Industrial Research, London, 1950, 24 pp.

FERGUSON, R.S., "Principles of Fire Protection applied in Part 3: Use and Occupancy, National Building Code of Canada." *Technical Paper No. 272 of the Division of Building Research*, National Research Council of Canada, Ottawa, 1970.

GRIFFITHS, L.G., AND HESELDEN, A.J.M., "The Use of Wooden Blocks as Simple Radiometers," *Fire Research Note No. 648*, Ministry of Technology and Fire Officers' Committee, Joint Fire Research Organizations, Herts, England, Feb. 1967.

LANGDON-THOMAS, G.J., AND LAW, M., "Fire and the External Wall," *Fire Note No. 8*, Ministry of Technology and Fire Officers' Committee, Joint Fire Research Organization, London, Oct. 1966.

LAW, M., "Radiation from Fires and Building Separation," *Fire Research Note No. 437*, Department of Scientific Research and Fire Officers' Committee, Joint Fire Research Organization, Boreham Wood, Herts, England, 1960.

— "Heat Radiation from Fires in a Compartment," *Fire Research Technical Paper No. 200*, Ministry of Technology and Joint Fire Research Organization, London, 1968.

—“Heat Radiation from Fires in a Compartment,” *Fire Research Technical Paper No. 5*, Department of Scientific and Industrial Research and Fire Officers’ Committee, Joint Fire Research Organization, London, 1963.

MCGUIRE, J.H., “Heat Transfer by Radiation,” *Special Report No. 2*, Department of Science and Industrial Research and Fire Officers Committee, London, 1953.

—“Fire and Spatial Separation of Buildings,” *Fire Technology*, Vol. 1, No. 4, November, 1965, p. 278.

WILLIAMS-LEIR, G., “Approximations for Spatial Separation,” *Fire Technology*, Vol. 2, No. 2, May, 1966, p. 136.

—“Another Approximation for Spatial Separation” *Fire Technology*, Vol. 6, No. 3, August, 1970, p. 189.

—“Program for Pocket Calculator to Derive Spatial Separations to Deter Fire Spread” *Computer Program No. 44 of the Division of Building Research*, National Research Council of Canada, Ottawa, May 1978.

BUILDING SIZE LIMITS HEIGHTS AND AREAS

Regulation of the allowable size of buildings as a means of controlling the magnitude of fires has long been recognized as an important feature in modern building codes.

Building size limits, either legally imposed by building laws or as a voluntary precautionary measure by designers, serve two important functions:

1. They limit the amount of fuel available that may be exposed to a single fire incident.
2. They limit the number of persons at risk in any single fire incident.

Although the need for limitations on the size of buildings is widely recognized, there has not been universal agreement on the limitations themselves or even on a method that will achieve a balance of the various risks.

General Principles of Building Size Limitations

The extent of fire spread in a building, apart from the success of suppression efforts, is influenced by the amount and arrangement of exposed combustibles within the building. In fire resistive types of construction, fire in most occupancies can be confined within the building itself even though the contents of one floor or portion of the building may be completely burned out.

Where the fire load is such that fires of an intensity in excess of the fire resistance of the structure may develop, it is necessary to provide for control of the magnitude of a potential fire and limit the exposure to the occupants by height and area limitations. Large buildings present greater fire potential simply because they may have more combustibles exposed to a fire. They also may contain more people who can be exposed to a fire. Evacuation of larger buildings is more difficult because of lengthier evacuation routes. Further, fires in large buildings may present more difficult fire control problems because of inaccessibility to the more remote interior spaces.

Height and area limits should be designed to limit the fire hazard and potential severity to a reasonably uniform level in all buildings. Sufficient data are available to make reasonably consistent evaluations of the relative severity of fires in different occupancies. Similarly, the value of protective construction features to achieve an acceptable and uniform level of risk among the various types of construction is known. Also, an evaluation can be made of the relative risk of loss of life from fire in a building based on the ability of the occupants to escape or find refuge. From these three factors, the fire and life safety risks in buildings can be compared and a building's size adjusted accordingly.

Limitations on building heights in building codes are somewhat empirical and have been derived not only from the characteristics of the types of construction and the occupancy, but also consideration of fire fighting and evacuation procedures.

If a building can be constructed to isolate different floors from one another so that a fire involving the entire combustible content on one level will not spread to another or impair the structural integrity of the building and smoke spread can be controlled, theoretically no height limitation is needed. Should, however, the likelihood exist that vertical fire spread may occur, then height limitations are necessary. If the time required for orderly evacuation of the building exceeds the duration that a compartment or floor can confine a potential fully-developed fire, height limitations are also necessary.

Area limitations established by a building code do not necessarily restrict a structure's overall size for a particular type of construction. By using fire walls to divide a structure into separate fire areas that are no greater than the allowable maximum there is, in effect, no theoretical limit to the area of a building of any construction type. The fire resistance of the dividing walls and the protection of the openings in such walls should be determined from the severity of the fire hazard of the occupancy and the type of construction.

Height and Area Limits in Existing Building Codes

Table 22 shows the basic allowable height and area limitations for Business, Educational, and Residential occupancies in the Basic Building Code, the Standard Building Code and the Uniform Building Code. In the table, the basic areas in square feet have been divided by a common area base of 2500 square feet (232 m²). The figures in parentheses illustrate the relative magnitudes of the areas. The table is

not all inclusive and does not necessarily represent all of the area and height variations that the various codes permit.

In these three model codes, the occupancies and the types of construction are roughly comparable. The height and area tables in codes are a matrix of combinations of these two factors and may contain up to 150 separate entries for allowable areas. This number would seem to imply that the values were derived with a high order of precision, but in fact they are the result of the application of a number of assumptions which may or may not be based upon any scientific information.

The allowable areas in the Basic Building Code, with its nine occupancy groups and ten types of construction, were derived for one story buildings from an analysis of fire and life losses in different occupancies and the use of numerical factors assigned to characterize the relative risk associated with the different types of construction defined in that code. The allowable areas in the code are a function of the following formulation:

Allowable Area = $U \times C \times$ Base Area

Where U = Relative Risk of Fire in an Occupancy
(Use or Occupancy Factor)

C = Relative Risk of Construction Type to Fire
(Construction Factor)

Base Area = Assumed area for most critical factors, i.e.,
highest risk occupancy and lowest risk construction type.

The use factors (U) in the formula were developed through study of NFPA fire records, statistics of fire incidence, property damage and life loss.

The construction factors (C) were developed for each type of construction by evaluating fire resistance of floor construction and exterior walls and whether the construction is combustible or noncombustible. The base area value was originally established at 1000 square feet (93 m²) and later increased to 1200 square feet (111 m²). The resultant areas in the Basic Building Code are relative and attempt to treat all uses of buildings and types of construction equally.

The allowable areas in early editions of the Standard Building Code were possibly derived from a somewhat similar analytical method but their origin is unknown. However, revisions to that code over the years have altered whatever relationships were originally assumed.

**Table 22—Basic Allowable Heights and Areas for Business, Educational and Residential Occupancies in Three Model Codes
(Heights in Stories/Feet, Areas in Square Feet)**

	Noncombustible					Combustible					
	Type I		Type II		Type III	Type IV		Type V			
	222	111	100	211		200	2HH	111	1C		
Business BBC	UH	7st/85'	5st/65'	3st/40'	4st/50'	3st/40'	5st/65'	3st/40'	5st/65'	3st/40'	2st/3
	UA	34,200 (13.7)	22,500 (9.0)	14,400 (5.8)	19,800 (7.9)	14,400 (5.8)	21,600 (8.6)	15,300 (6.1)	15,300 (6.1)	7,200 (2)	7,200 (2)
SBC	UH	—	5st/65'	2st/55'	5st/65'	2st/55'	5st/65'	2st/50'	5st/65'	2st/50'	2st/4
	UA	—	25,500 (10.2)	17,000 (6.8)	21,000 (8.4)	14,000 (5.6)	25,500 (10.2)	13,500 (5.4)	13,500 (5.4)	9,000 (3)	9,000 (3)
UBC	UH	12st/160'	4st/65'	2st/55'	4st/65'	2st/55'	4st/65'	3st/50'	4st/65'	3st/50'	2st/4
	UA	39,900 (15.9)	18,000 (7.2)	12,000 (4.8)	18,000 (7.2)	12,000 (4.8)	18,000 (7.2)	14,000 (5.6)	14,000 (5.6)	8,000 (3)	8,000 (3)
Educational BBC	UH	5st/65'	3st/40'	2st/30'	3st/40'	2st/30'	3st/40'	1st/20'	3st/40'	1st/20'	1st/2
	UA	34,200 (13.7)	22,500 (9.0)	14,400 (5.8)	19,800 (7.9)	14,400 (5.7)	21,600 (8.6)	15,300 (6.1)	15,300 (6.1)	7,200 (2)	7,200 (2)
SBC	UH	—	2st/65'	1st/55'	2st/65'	1st/55'	2st/65'	2st/50'	2st/65'	2st/50'	1st/4
	UA	—	18,000 (7.2)	12,000 (4.8)	18,000 (7.2)	12,000 (4.8)	18,000 (7.2)	12,000 (4.8)	12,000 (4.8)	8,000 (3)	8,000 (3)
UBC	UH	4st/160'	2st/65'	1st/55'	2st/65'	1st/55'	2st/65'	2st/50'	2st/65'	2st/50'	1st/4
	UA	45,200 (18.1)	20,200 (8.1)	13,500 (5.4)	20,200 (8.1)	13,500 (5.4)	20,200 (8.1)	15,700 (6.3)	15,700 (6.3)	9,100 (3)	9,100 (3)
Residential BBC	UH	9st/100'	4st/50'	3st/40'	4st/50'	3st/40'	4st/50'	3st/40'	4st/50'	3st/40'	2st 3
	UA	22,800 (9.1)	15,000 (6.0)	9,600 (3.8)	13,200 (5.3)	9,600 (3.8)	14,400 (5.8)	10,200 (4.1)	10,200 (4.1)	4,800 (1)	4,800 (1)
SBC	UH	—	5st/65'	2st/55'	5st/65'	2st/55'	3st/65'	3st/50'	3st/65'	3st/50'	2st/5
	UA	—	18,000 (7.2)	12,000 (4.8)	18,000 (7.2)	12,000 (4.8)	18,000 (7.2)	10,500 (4.2)	10,500 (4.2)	7,000 (2)	7,000 (2)
UBC	UH	12st/160'	4st/65'	2st/55'	4st/65'	2st/55'	4st/65'	3st/50'	4st/65'	3st/50'	2st/4
	UA	29,900 (12.0)	13,500 (5.4)	9,100 (3.6)	13,500 (5.4)	9,100 (3.6)	13,500 (5.4)	10,500 (4.2)	10,500 (4.2)	6,000 (2)	6,000 (2)

Numbers in parentheses () are the result of dividing the areas by a base area of 2,500 square feet.

UH = Unlimited Height

UA = Unlimited Area

Residential data do not include single family dwellings.

The Uniform Building Code area limitations appear to be an outgrowth of tradition. Generally, they fit into the pattern of code allowances although they seem conservative for some construction types.

American Insurance Association's National Building Code provides for basic area limits for the seven different types of construction defined in the code. There are no general area requirements based on occupancy, but modifications are made under special occupancy requirements in the code.

The National Building Code of Canada does not use the conventional tabulation of height and area limitations as is done in other model codes. For each individual use group and subgroup of a given height and area, fire protection requirements are prescribed for floors, load-bearing walls, columns, arches and roof assemblies. This arrangement does not permit a direct comparison of the allowable heights and areas in this code and the other model codes. It is worth noting that the fire resistance requirements for large area buildings are considerably lower for a number of low fire load occupancies than specified in the other model codes.

A table of allowable building heights and areas, though a critically important concern for the architect, the builder and the owner, is only a convenience; it should not be regarded as an end in itself. The basic areas in codes are not the maximum size to which a building may be constructed. For example, they may be increased substantially where supplementary fire protection, such as automatic sprinklers, are provided.

The most suitable materials and fire resistance of a building of a given size are difficult to determine from a table of allowable heights and areas alone. The figures by themselves define only the limits of a building. What constitutes a safe building involves many other factors.

A Rational Approach to Building Area Limits

One of the purposes of laws regulating building sizes is to limit the maximum fire risk to be tolerated and to avoid the creation of unbalanced risks. Codes should seek to limit the hazard to a reasonable and uniform level, so that no one building and its occupancy will create a greater fire risk than another.

There are several basic factors that require consideration in the development of a rational approach to height and area limitations. The more important factors include:

1. Relative fire severity resulting from the fire load (combustibles) associated with each occupancy.
2. Relative fire severity resulting from the fire load (combustibles) used in the construction of the building.
3. Construction features which tend to retard the spread of fire, i.e., fire resistance.
4. The number and type of occupants and their ability to evacuate a building during the early stages of a fire.

It is feasible, by the use of available data and through experience, to evaluate these factors, assess the risks involved, and arrive at a relationship that will equalize those risks. By that procedure, each factor would be given its proper weight every time it enters the calculations in developing area limits, thus achieving greater consistency.

There have been a number of methods and systems proposed to establish allowable building areas in building codes.

Some of these systems were developed by evaluating the factors mentioned above and by assigning values to them, resulting in a series of areas related to the risks for each building use and construction type.

One approach developed by B. L. Wood in a paper, "What Size Buildings," was published in an earlier edition of this book. Its approach was based upon using the occupancy fire loads to determine a relative fire severity for each building use, adding to that the fire load represented by the building construction where combustible materials are used, and deducting a representative fire load value for those construction features which retard the spread of fire, i.e., fire resistance of the floors. Thus, an occupancy having a 10 psf (49 kg/m²) fire load (1-hour fire severity) in a wood frame building having about 10 psf (49 kg/m²) of combustible framing would have a resultant fire load equivalent of 20 pounds per square foot (98 kg/m²). If the floor construction of the building had a 1-hour fire resistance rating the fire load equivalent would be reduced by 10 pounds per square foot (49 kg/m²).

By assigning similar values to each occupancy and construction type, fire load equivalents, which could be factored to show the relative risk, were developed and tabulated. These values were then further modified by applying a habitational factor which was derived by evaluating the number of occupants accommodated within the areas and the relative risk for each use group in an effort to equalize those risks.

Using this approach, a final tabulation of factors was developed for each combination of occupancy and type of construction. These factors

were then multiplied by a base area similar to that done in the Basic Building Code. If this approach is to be followed, more research and study would be required to develop more data on occupancy risk factors and on construction risk factors.

Area Limits for Multistory Buildings

The area limits tabulated in the model building codes are for one story buildings.

Typically, codes define "building area" as the area included within surrounding exterior walls or exterior walls and fire walls exclusive of vent shafts and courts. If a building, or a part of it, does not have exterior walls, the area is defined as that usable area under the horizontal projection of the roof or floor above. Building area, as defined, is not the cumulative or total area of all floors or stories in the building. The area limits for multistory buildings are generally reduced to some proportion of the basic one-story area.

The current model codes do not treat the subject of multistory area limits in the same manner. The Basic Building Code (BOCA) permits two-story buildings to be of the same basic area as one-story buildings, but includes provisions for a percentage reduction in the area of buildings over two stories in height. The reductions vary depending upon the type of construction, as shown in Table 23.

The National Building Code (AInSA) reduces the allowable area per floor for all types of construction (except Fire Resistive) by one third for any building two or more stories in height.

The Standard Building Code (SBCCI) requires no area reduction of the basic allowable area for multistory buildings. However, all unprotected construction is limited to two stories in height unless sprinklered. The New York City Building Code also follows this procedure, but the basic area limits for one story buildings tend to be lower than those in the model codes.

The Uniform Building Code (ICBO) permits two-story buildings to be of the same area as one-story buildings. However, in buildings higher than two stories, the total floor area is limited to twice the allowable one story area.

The National Building Code of Canada generally limits the total area of multistory buildings to no more than the total base area of a one story building, except in Residential Occupancies where the total area is permitted to be 1.5 times the base area. For occupancies where unlimited area is permitted for one-story buildings, the total area of a

**Table 23—Area Limits for Multistory Buildings
Basic Building Code—1981**

No. of Stories	Type 1A and 1B Construction	Type 2A Construction		Type 2B, 2C, 3A 3B, 3C, 4A, 4B Construction	
	No Reduction in Areas for Multistory Buildings	Percent Reduction	Ratio of Total Building Area to One Story Area	Percent Reduction	Ratio of Total Building Area to One Story Area
1		None	1.0	None	1.0
2		None	2.0	None	2.0
3		5%	2.85	20%	2.4
4		10%	3.6	20%	3.2
5		15%	4.25	30%	3.5
6		20%	4.80	40%	3.6
7		25%	5.25	50%	3.5
8		30%	5.6	60%	3.2
9		35%	5.85	70%	2.7
10		40%	6.00	80%	NP

NP = Not Permitted

multistory building is limited to a total area specified for two-story buildings.

In effect, the area limits for multistory buildings in most of the model codes allow a greater quantity of combustible materials or fire load than are allowed in one-story buildings. This seems to violate a basic premise for establishing area limitations, which is to equalize the risks from a fire occurring in any occupancy or type of construction. With the exception of those types of construction capable of confining a fire to the floor of origin and resisting the burnout of the contents of the occupancy, it would seem reasonable to restrict the total floor area of a multistory building to that allowed for a single story building.

Area Increase for Accessible Building Perimeter

As more of a building's perimeter directly faces adjacent streets or other open accessible spaces, it can be assumed that fire fighting operations can be more effective. A relationship between access for fire fighting is reflected in most building codes by allowing an increase in the basic areas where a building fronts on more than one street or open space.

Some building codes permit an increase in the maximum allowable area where a building has "frontage" length on two or more streets but do not specify a minimum frontage or minimum street width as a condition for the area increase. Such an omission may allow a dangerous condition to develop.

Consider, for example, a building with dimensions of 100 by 400 feet (30 by 122 m). It makes a vast difference, from the fire fighter's point of view, whether it is the 100-foot (30 m) dimension or the 400-foot (122 m) dimension that faces on a street or other accessible public place. There is a far greater likelihood that a fire can be controlled if it can be attacked from the 400-foot (122 m) side than the 100-foot (30 m) side. Obviously, in a deep narrow building with only access from the narrow end, fire fighting is more difficult as smoke and heat can build up in areas remote from doors and windows.

Modern building codes allow building areas to be increased when the open frontage exceeds 25 percent of the building's perimeter. The increase may be by 100 to 150 percent of the basic area, as determined by the proportion of accessible building frontage. Codes also stipulate a minimum width for the street or public space on which that frontage is located before the increase is allowed. The codes may further base the amount of area increase on the amount by which the width of the street

or public space exceeds a specified minimum width, generally 20 to 50 feet (6 to 15 m). Although some codes adjust the allowable area increase in accordance with different street widths, this refinement is not necessary because only a basic minimum street width need to be defined. Greater widths do not give appreciably better access.

Area Increase for Automatic Fire-Extinguishing Equipment

To limit fire spread, proper construction and subdivision of buildings are of prime importance. Effective fire control can also be provided by automatic fire-extinguishing equipment. In recognition of the performance record of automatic fire-extinguishing equipment, such as sprinkler systems, it has become established building code practice to permit an increase in the maximum allowable floor areas wherever automatic fire-extinguishing equipment of an approved type is installed throughout a building.

This area increase is essentially similar in the various model codes. The Standard Building Code (SBCCI) permits the allowable area of a building that has automatic protection to be tripled in one-story buildings and doubled for multistoried buildings, except that no increase is allowed where the sprinkler protection is mandatory or where a height increase has been allowed because of sprinklers. The Standard Code table of allowable heights and areas contains the separate tabulated areas for sprinklered buildings and unsprinklered buildings instead of containing a modifying section in the code. This procedure is also followed in the New York City Code and is preferable because it eliminates confusion in interpreting the code language.

The Basic Building Code (BOCA) and the National Building Code of Canada allow a 200 percent increase in area for one story buildings and a 100 percent increase for multistory buildings. The Basic Building Code does not permit the area increases in hazardous occupancies where automatic protection is mandatory.

The Uniform Building Code (ICBO) permits these same area increases for single- and multistory buildings having automatic protection systems provided that such systems are not required by the code, are not used as a substitute for 1-hour construction, or are not used to gain a height increase above that allowable. The National Building Code (AInsA) permits a 300 percent increase of the basic area for sprinklered one-story buildings and a 200 percent increase of the area for multistory structures. These area increases are also applicable to

buildings which may otherwise be required to have automatic protection—a provision not found in some of the other model codes.

Buildings of Unusually Large Area

Where large, undivided floor areas are needed, as in warehouses and modern industrial plants, fire-resistive construction would usually be required by building regulations. However, if the total fire load in such occupancies is extremely low, less than one or two pounds per square foot, fire-resistive construction is unnecessary. For example, a one-story building of noncombustible construction in which only noncombustible materials are processed, used, or stored is less of a fire hazard than any other combination of occupancy and type of construction. With this type of occupancy, it is reasonable to permit unlimited areas for one-story, noncombustible buildings. For other occupancies where the fire load is moderately low, unlimited areas may also be allowed for one-story buildings if automatic fire extinguishing systems are installed. All of the model building codes recognize these conditions although they treat the subject of unlimited areas somewhat differently.

In the Basic Building Code (BOCA) all buildings and structures designed to house low hazard industrial processes, including power plants, rolling mills and foundries and which require large areas and heights, are exempt from the height and area limitations in the code. Also, unlimited areas are permitted for certain types of one-story buildings housing Assembly (A3 lecture halls, recreation centers, terminals, etc.), Business, Factory-Industrial, Mercantile and Storage Occupancies provided the building is completely sprinklered and separated by open space on all sides. The sprinkler requirement may be waived for noncombustible and heavy timber buildings used for storage of noncombustible materials not packed or crated in combustible containers.

The Standard Building Code (SBCCI) contains similar provisions for unlimited area one-story buildings for most of these same occupancies.

In the Uniform Building Code (ICBO), the unlimited area is permitted for both one- and two-story sprinklered buildings housing all of these same occupancies except Assembly. Also, sprinklers are not required in one-story buildings of noncombustible, heavy timber or one-hour protected Type III construction when housing low hazard industrial processes or storing noncombustible materials.

The National Building Code of Canada has similar allowances for

low fire load occupancies but permits the sprinkler system to be omitted only where the building is of noncombustible construction.

Building Height Limits

As mentioned previously, building height limits in building codes have been more or less empirically derived and have been based upon the structural fire resistance characteristics of the various types of construction and the factors relating to fire fighting access and evacuation of occupants. A review of the current height limits for three typical occupancies in building codes (Table 22) reflects this approach.

In general, height limitations in the current codes can be viewed as reflecting three general categories of building heights, low-rise (one-, two- and three-story buildings), intermediate-height (four- to six-story buildings), and high-rise or unlimited height buildings.

Low-Rise Buildings—The low-rise building of one, two or three stories usually of a height of 35 to 40 feet (11 to 12 m) has a number of advantages from a fire-safety standpoint. First, virtually every fire department, no matter what size the jurisdiction, would have equipment capable of reaching the third floor of a building and, therefore, exterior as well as interior fire fighting is possible. A second advantage, and possibly of greater significance with respect to life safety, is the evacuation time for low-rise buildings. With proper design of means of egress, such buildings can be evacuated in a very short time if the occupants are alert and capable of exiting under their own power. In addition, exterior rescue from the low-rise building is a possibility. Under these conditions, the life safety benefits of structural fire resistance are less significant than for buildings of greater height.

Therefore, most occupancy and type of construction combinations should be allowed for low-rise buildings within the specified area limits in the building code. However, buildings where the occupants mobility is limited or where extremely hazardous conditions exist may be further limited or prohibited unless they are sprinklered or of fire resistive construction, or both.

Intermediate-Height Buildings—The intermediate-height building, which most codes recognize as having a height from 55 to 65 feet (17 to 20 m), or about five or six stories, does not have the same advantage as the low-rise building from the standpoint of exterior fire fighting. Many communities do not have the equipment capability or personnel to successfully provide for exterior evacuation or fire attack for buildings of this height. Also, at this greater height exterior fire fighting cannot be

expected to be as effective as in the low-rise building. Consequently, both structural fire resistance and interior fire protection for means of egress and internal fire attack are necessary. Although it is feasible to evacuate a building of this height limit within reasonable time limits, the evacuation might have to occur while a fully-developed fire is in progress at any level. Therefore, such buildings not only should be capable of resisting the anticipated fire, but also the means of egress must be of such design as to allow them to remain safe and usable.

Accordingly, intermediate-height buildings should be restricted to those types of construction that provide sufficient structural fire resistance (perhaps with a factor of safety) sufficient to withstand the effects of a fully developed fire in the occupancy involved. Obviously, greater restrictions on height for some types of construction are needed where the life safety implications of even a small fire are greater than structural fire resistance alone can offset. For example, Assembly, Institutional, Hazardous and Mercantile occupancies may not be permitted at these heights in less-fire resistive types of buildings unless they are sprinklered.

High-Rise Buildings— In recent years, much attention has been given to the development of special regulations for high-rise buildings. In most codes any building exceeding 75 feet (23 m) in height is classified as high-rise and must meet certain supplementary code requirements designed to provide additional safety. The 75-foot (23 m) height was established because it was considered to be the limit at which effective exterior fire attack or evacuation was possible. Many jurisdictions should consider the capabilities of their present fire department equipment before adopting the 75-foot (23 m) height for classifying a building as high-rise. In many communities, buildings of much lesser heights may present a serious challenge to fire department personnel not experienced or equipped to attack fires.

In the high-rise building, structural fire resistance is an important factor with respect to life safety. It is necessary to provide time for both evacuation purposes and for internal fire attack. Accordingly, the fire resistance of such buildings should exceed the expected fire severity represented by a fully developed occupancy fire. Accordingly, only fire resistive buildings with fire resistance adequate to withstand a fully developed fire should be permitted in the high-rise height category.

Height Allowances for Sprinklered Buildings

Both the Basic Building Code and the Uniform Building Code permit

a building's height to be increased one additional story when an automatic fire-extinguishing system is installed throughout. These codes do not permit the increase for buildings housing hazardous occupancies. The Uniform Building Code does not permit the increase where an area increase has already been allowed. The National Building Code of Canada allows the height increase only in a few occupancies.

The Standard Building Code does not have a specific code provision relating to height increases for sprinklered buildings but, in its tabulation of allowable heights and areas, increased heights are allowed for certain types of construction housing Business, Factory-Industrial, Mercantile, Residential and Storage occupancies. In some instances, an additional two or three stories are permitted for sprinklered buildings.

The rationale for increase in height for sprinklered buildings in the various model codes is unknown. It appears to be based on the recognition of the benefits resulting from sprinklers in improving the conditions for evacuation and fire fighting.

Height Limits for Low Hazard Occupancies

For some occupancies housing low-hazard processes and where unusual heights are necessary for their operations, height limitations are waived by most codes provided the building is of noncombustible construction. Buildings housing power plants, steel mills, fabricating shops and cement mills are examples of the types of occupancies exempt from the codes' height limits.

Summary

Regulation of the allowable heights and areas of buildings is an important means of controlling the hazards from fire by limiting the total fuel exposed to a single fire and by limiting the number of occupants at risk. The height and area limits in modern building codes are not in agreement although they generally use a matrix of the combinations of occupancies and types of construction, giving up to 150 separate values for heights and areas. A rational approach to building size limits with the purpose of balancing the risks between occupancies and types of construction has been attempted by some code writers and should be further developed when better data on occupancy and construction risk factors have been developed. There is a need for more careful consideration of the area limits for multistory buildings in modern building codes.

Height limitations in building codes fall into three general categories; low-rise, intermediate-height and high-rise. In low-rise buildings all occupancies, except assembly, institutional and hazardous, should be allowed in all types of construction. Intermediate-height buildings should be restricted to construction types that provide structural fire resistance sufficient to resist a burnout of the occupancy. High-rise buildings should be of a construction type able to withstand the effects of fully developed fire with some factor of safety.

References

CARAVATY, R.D., WINSLOW, W.F., AND HAVILAND, D.S., *Area and Height Limitations in Modern Building Codes: A Survey and Some Directions*, U.S. Department of Housing and Urban Development, Federal Housing Administration, Washington, D.C., 1970.

NATIONAL BUREAU OF STANDARDS, *Recommended Minimum Requirements for Fire-Resistance in Buildings*, Building and Housing, No. 14, Washington, D.C., 1931.

STREHAN, GEORGE E., *General Height and Area Limitations*, Building Officials Conference of America Codes, 1953.

WOOD, B.L., *What Size Buildings*, American Iron and Steel Institute, New York, NY, April 27, 1948.

WOOD, B.L., *Fire Protection Through Modern Building Codes*, American Iron and Steel Institute, New York, NY, 1945, 1950, and 1961 Editions.

GLOSSARY

- Addition.** An extension or increase in floor area or height of a building or structure.
- Approved.** Approval granted by the building official or other authority having jurisdiction, indicating that the building or structure complies with the governing code.
- Apartment.** A dwelling unit situated within a building and occupying only a portion of the total building area.
- Apartment house.** A building or portion thereof containing more than two dwelling units and not classified as a one- or two-family dwelling.
- Area (building).** The area included within surrounding exterior walls (or exterior walls and fire walls) exclusive of vent shafts and open courtyards. Areas of the building not provided with surrounding walls shall be included in the building area if included within the horizontal projection of the roof or floor above.
- Automatic.** As applied to fire protection devices is a device or system providing an emergency function without the necessity of a human intervention and activated as a result of reaching a predetermined temperature, rate of rise of temperature, or increase in the level of combustion products; such as incorporated in an automatic sprinkler system, automatic fire door, etc.
- Basement.** That portion of a building which is partly below and partly above grade, and having at least one-half of its clear height above grade.
- Building.** A structure enclosed with exterior walls or fire walls built,

erected, and framed of component structural parts, designed for the housing, shelter, enclosure, or support of individuals, animals, chattels, or property of any kind. The term "building" shall be construed as if followed by the words "or portion thereof."

Building (existing). Any structure erected prior to the adoption of the appropriate code, or one for which a legal building permit has been issued.

Building official. The officer or other designated authority charged with the administration and enforcement of this code, or his duly authorized representative.

Cellar. That portion of a building which is partly or completely below grade, and having at least one-half of its clear height below grade.

Chimney connector. A pipe which connects a fuel burning appliance to a chimney.

Combustible. Capable of undergoing combustion in air, at pressures and temperatures that might occur during a fire in a building, or in a more severe environment when specified.

Combustible construction. Construction having any structural element that is made of combustible material.

Court. An open, uncovered, and unoccupied space on the same lot with a building. (Also referred to as a courtyard.)

Court (inner). Any court surrounded on all sides by the building other than an outer court.

Court (outer). A court extending to an opening upon a street, public alley, or other approved open space not less than fifteen (15) feet wide, or upon a required yard.

Dwelling. A single unit providing complete, independent living facilities for one (1) or more persons including permanent provisions for living, sleeping, eating, cooking, and sanitation.

Exit access. That portion of a means of egress which leads to an entrance to an exit.

Exit. That portion of a means of egress which is separated from all other spaces of a building or structure by construction or equipment, as required by the appropriate Code, to provide a protected way of travel to the exit discharge.

Exit discharge. That portion of a means of egress between the termination of an exit and a public space.

Fire door. A door and its assembly, so constructed and assembled in place as to give protection against the passage of fire.

Fire Endurance. A measure of the elapsed time during which a material or assembly continues to exhibit fire resistance under specified conditions of test and performance. As applied to elements of buildings, it shall be measured by the methods and to the criteria defined in ASTM Methods E 119, Fire Tests of Building Construction and Materials ASTM Methods E 152, Fire Tests of Door Assemblies, or ASTM Methods E 163, Fire Tests of Window Assemblies.

Fire resistance. The property of a material or assembly to withstand fire or give protection from it. As applied to elements of buildings, it is characterized by the ability to confine a fire or to continue to perform a given structural function, or both.

Fire resistive. Having fire resistance.

Fire separation wall. Vertical construction of fire resistance rated materials, having no unprotected openings, designed to restrict the spread of fire within a single story.

Firestop. A solid, tight barrier in a concealed space, placed to prevent the spread of fire and smoke through such spaces.

Fire wall. A fire resistance rated wall, having protected openings, which restricts the spread of fire and extends continuously from the foundation to or through the roof.

Flammable. Subject to ignition and rapid flaming combustion.

Grade line. A reference plane representing the average of finished ground level adjoining the building at the exterior walls.

Habitable space. Space in a structure for living, sleeping, eating, or cooking. It does not include bathrooms, toilet compartments, closets, halls, storage or utility space, and similar areas.

Horizontal separation. A separation distance provided between the exterior wall of a building and a common property line as the result of an open unobstructed yard or other open space. The distance is usually measured at a right angle to the property line.

Interior finish. The materials comprising the exposed interior surfacing of the walls, partitions, columns, beams, or ceilings of a building for decoration, accoustical correction, insulation, or other purpose. Floor coverings, interior doors, and trim are not included within the definition of interior finish.

Load (dead). The weight of all permanent structural and non-structural components of a building, such as walls, floors, roofs, and fixed service equipment.

Load (live). The weight superimposed by the use and occupancy of the building, not including the wind load, earthquake load, or dead load.

Mall. covered or roofed interior area used as a pedestrian way and connecting buildings or portions of a building housing one or more tenants.

Mezzanine. An intermediate level between the floor and ceiling of any story and covering not more than thirty-three (33) percent of the floor area of the room in which it is located.

Means of egress. A continuous and unobstructed way of exit travel from any point in a building or structure to a public space and consists of three separate and distinct parts: (a) the way of exit access, (b) the exit, and (c) the way of exit discharge. A means of egress comprises the vertical and horizontal ways of exit travel and shall include intervening room spaces, doors, hallways, corridors, passageways, balconies, ramps, stairs, enclosures, lobbies, escalators, horizontal exits, courts, and yards.

Noncombustible. The property of a material to withstand high temperature without ignition. As applied to elementary materials of which building materials are composed, it shall be as measured by the methods and to the criteria defined in ASTM Method E 136, Test for Noncombustibility of Elementary Materials.

Occupancy. The purpose for which a building, or part thereof, is used or intended to be used.

Parapet. A wall extending above the adjacent roof.

Partition. A wall that subdivides spaces within any story of a building.

Partition (Smoke-Stop). A partition across an exit passageway provided with a door or doors to restrict the spread of smoke and fire by reducing draft.

Penthouse. An enclosed structure above the roof of a building, other than a roof structure or bulkhead, occupying not more than thirty-three and one-third (33-1/3) percent of the roof area.

Permit. An official document or certificate issued by the authority having jurisdiction authorizing performance of a specified activity. (Note: Designating the Building Official as the "authority" having jurisdiction is not considered a change in definition.)

Plenum. An air compartment or chamber to which one or more ducts are connected and which forms part of an air distribution system.

Public space. A legal open space on the premises, accessible to a public way or street, such as yards, courts, or open spaces permanently devoted to public use which abuts the premises.

Roof structure. An enclosed structure on or above the roof of any part of a building.

Spandrel wall. That portion of the exterior wall of a building which is situated immediately above an exterior wall opening of that building.

Standpipe. A system of piping intended to convey water for fire fighting to the upper stories of a building.

Story. That portion of a building included between the upper surface of a floor and upper surface of the floor or roof immediately above.

Story (first). The lowest story entirely above the grade plane.

Surface flame spread. The propagation of a flame away from the source of ignition across the surface of a liquid or a solid.

Structure. An assembly of materials forming a construction for occupancy or use including among others, building, stadiums, public assembly tents, reviewing stands, platforms, stagings, observation towers, radio towers, water tanks, trestles, piers, wharves, open sheds, coal bins, shelters, fences, and display signs. The term "structure" shall be construed as if followed by the words "or part thereof."

Vent system. A continuous open passageway from the flue collar or draft hood of a fuel burning appliance to the outside atmosphere for the purpose of removing products of combustion.

Vertical opening. An opening through a floor or roof.

Wall (bearing). A wall supporting any vertical load in addition to its own weight.

Wall (curtain). A nonbearing exterior wall supported by the structural framework of the building.

Wall (fire). See Fire wall and Fire Separation Wall.

Wall (nonbearing). A wall which supports no vertical load other than its own weight.

Wall (party). A wall on a common property line used or adapted for joint service between two adjacent buildings.

Wall (spandrel). That portion of the exterior wall of a building which is situated immediately above an exterior wall opening of that building.

APPENDIX A

BOARD FOR THE COORDINATION OF THE MODEL CODES RECOMMENDED OCCUPANCY CLASSIFICATIONS

Appendix A is reprinted with approval by Building Code Officials and Code Administrators, International, Inc., Homewood, Illinois. Copyright, 1980.

ASSEMBLY OCCUPANCY "A"

Assembly occupancy "A" includes among others, the use of a building or structure, or a portion thereof, for the gathering together of persons for purposes such as civic, social or religious functions, recreation, food or drink consumption, or awaiting transportation. A room or space used for assembly purposes by less than fifty (50) persons and accessory to another occupancy shall be included as a part of that major occupancy.

Assembly occupancies shall include the following:

A1 Assembly occupancies, usually with fixed seating, intended for the production and viewing of the performing arts or motion pictures, including:

- Motion picture theaters
- Television and radio studios admitting an audience
- Theaters

A2 Assembly occupancies intended for worship, recreation or amusement and other assembly uses not classified elsewhere in Group A, including:

- Art galleries
- Auditoriums
- Bowling alleys
- Churches
- Clubs
- Community halls
- Courtrooms
- Dance halls
- Exhibition halls
- Gymnasiums
- Indoor swimming pools
- Indoor tennis courts
- Lecture halls
- Libraries
- Museums

Passenger stations—(waiting area)
Funeral parlors
Pool and billiard parlors
Amusement arcades

A3 Assembly occupancies intended for food and drink consumption, including:

Restaurants
Night clubs
Banquet halls
Taverns and bars

A4 Assembly occupancies intended for reviewing of indoor sporting events and activities without spectator seating, including:

Arenas
Armories
Skating rinks
Swimming pools
Tennis courts

A5 Assembly occupancies intended for participation in or reviewing outdoor activities, including:

Amusement park structures
Bleachers
Grandstands
Stadiums
Fairs
Carnivals
Drive-in theaters

BUSINESS OCCUPANCY “B”

Business Occupancy “B” includes among others, the use of a building or structure, or a portion thereof, for office, professional or service type transactions, including storage of records and accounts.

Business occupancies shall include the following:

Animal hospitals, kennels, pounds
Automobile and other motor vehicle showrooms
Banks
Barber shops
Beauty shops
Car wash
Civic administration
Clinic—outpatient
Dry cleaning; pick-up and delivery stations and self-service
Educational occupancies above the 12th grade
Electronic data processing
Fire stations

- Florist and nurseries
- Laboratories; testing and research
- Laundries; pick-up and delivery stations and self-service
- Motor vehicle service stations
- Police stations
- Post offices
- Print shops
- Professional services; attorney, dentist, physician, engineer, etc.
- Radio and television stations
- Telephone exchanges

EDUCATIONAL OCCUPANCY “E”

Educational Occupancy “E” includes among others, the use of a building or structure, or a portion thereof, by six or more persons at any one time for educational purposes through the 12th grade.

Schools for business or vocational training shall conform to the requirements of the trade, vocation or business taught.

FACTORY INDUSTRIAL OCCUPANCY “F”

Factory Industrial Occupancy “F” includes among others, the use of a building or structure, or a portion thereof, for assembling, disassembling, fabricating, finishing, manufacturing, packaging, processing or repair operations that are not classified as a Hazardous Occupancy.

Certain industrial facilities, not classed as hazardous occupancies such as cement plants, shipyards, sawmills, steel mills, railroad shops, production and distribution of electricity, gas or steam shall be exempt from the height and area limitations of the code.

F-1 Moderate Hazard Factory-Industrial uses which are not classified as **Factory-Industrial F-2 Low Hazard** shall be classified as **F-1 Moderate Hazard** and includes the following:

- Aircraft
- Appliances
- Athletic equipment
- Automobile and other motor vehicles
- Bakeries
- Beverages; alcoholic
- Bicycles
- Boats; building
- Broom or brush
- Business machines
- Canvas or similar fabric
- Cameras and photo equipment
- Carpets and rugs, including cleaning
- Clothing
- Construction and agricultural machinery

Disinfectants
Dry cleaning and dyeing
Electronics
Engines; including rebuilding
Film; photographic
Food processing
Furniture
Hemp products
Jute products
Laundries
Leather products
Machinery
Metal
Motion pictures and television filming
Musical instruments
Optical goods
Paper mills or products
Plastic products
Printing or publishing
Recreational vehicles
Refuse incineration
Shoes
Soaps and detergents
Textiles
Tobacco
Trailers
Upholstering
Wood, distillation
Millwork (sash and door)
Woodworking—cabinet

F-2 Low Hazard Factory-Industrial uses which involve the fabrication or manufacturing of noncombustible materials which during finishing, packing or processing do not involve a significant fire hazard shall be classified as F-2 Occupancies and shall include the following:

Beverages; nonalcoholic
Brick and masonry
Ceramic products
Foundries
Glass products
Gypsum
Ice
Steel products; fabrication, assembly

HAZARDOUS OCCUPANCY “H”

Hazardous Occupancy “H” includes among others, the use of a building or structure, or a portion thereof, that involves the manufacturing, processing, generation or storage of corrosive, highly toxic, highly combustible, flammable or explosive materials that constitute a high

fire or explosion hazard, including loose combustible fibers, dust and unstable materials.

Hazardous materials are defined as follows:

Combustible Dust is any solid material sufficiently comminuted for suspension in still air which, when so suspended, is capable of self-sustained combustion.

Combustible fibers are readily ignitable and free burning fibers such as cotton, sisal, henequen, jute, hemp, tow, cocoa fiber, oakum, baled waste, baled wastepaper, kapok, hay, straw, excelsior, spanish moss and other like material.

Combustible liquid is a liquid having a flash point at or above 100 degrees F, combustible liquids shall be subdivided as follows:

Class II liquids shall include those having flash points at or above 100 degrees F and below 140 degrees F.

Class III-A liquids shall include those having flash points at or above 140 degrees F and below 200 degrees F.

Class III-B liquids shall include those having a flash point at or above 200 degrees F.

Corrosive liquids are those acids, alkaline caustic liquids and other corrosive liquids which, when in contact with living tissue, will cause severe damage of such tissue by chemical action or are liable to cause fire when in contact with organic matter or with certain chemicals.

Explosive Material is any chemical compound, mixture or device, the primary and common purpose of which is to function by explosion with substantially simultaneous release of gas and heat, the resultant pressure being capable of destructive effects.

Flammable liquid is any liquid having a flash point below 100 degrees F and having a vapor pressure not exceeding 40 pounds per square inch (absolute) at 100 degrees F. Class I liquids shall include those having flash points below 100 degrees F, and may be subdivided as follows:

Class I-A shall include those having flash points below 73 degrees F, and having a boiling point below 100 degrees F.

Class I-B shall include those having flash points below 73 degrees F and having a boiling point at or above 100 degrees F.

Class I-C shall include those having flash points at or above 73 degrees F.

The flash point of liquids having a flash point at or below 175 degrees

F, except for fuel oils and certain viscous materials, shall be determined in accordance with the Standard Method of Test for Flash Point by the Tag Closed Tester, ASTM D56-79.

The flash point of liquids having a flash point above 175 degrees F, except for fuel oils, shall be determined in accordance with the Standard Method of Test for Flash Point by the Cleveland Open Cut Tester, ASTM D92-78.

The flash point of fuel oil and certain viscous materials having a flash point at or below 175 degrees F shall be determined in accordance with the Standard Method of Test for Flash Point by the Pensky-Martens Closed Tester, ASTM D93-80.

Flammable gas—any gas having a flammability range with air greater than 1 percent by volume which is a liquid while under pressure and having a vapor pressure in excess of 27 pounds per square inch absolute at temperatures of 100 degrees F.

Liquefied petroleum gas is any material which is composed predominately of the following hydrocarbons or mixtures of them such as: propane, propylene, butane (normal butane or isobutane) and butylenes.

Nitromethane is an unstable and combustible material. At 599 degrees F and 915 PSIG it decomposes explosively.

Oxidizing materials are substances that readily yield oxygen to stimulate combustion such as sodium nitrate, potassium chlorate pyroxylin plastic.

Organic peroxide is an unstable chemical that is flammable and oxidizing.

Unstable materials polymerize, decompose, condense or become self-reactive when exposed to air, water, heat, shock or pressure.

Exceptions: The following shall not be classified as a Hazardous Occupancy:

1. Any building housing less than the exempt amount of those materials shown in Table A.
2. Buildings containing rooms conforming to the requirements for "Special Rooms for Hazardous Material."
3. Rooms containing flammable liquids in tightly closed containers of one gallon capacity or less for retail sale for private use on the premises and in quantities not exceeding two gallons per square foot of room area.
4. Rooms used for preparation or storage of food products for retail sale on the premises.

5. Retail paint sales rooms with quantities of paint not exceeding two gallons per square foot of room area.
6. Liquor stores and distributors without bulk storage.
7. The storage or use of materials for agricultural purposes for use on the premises.
8. Closed systems housing combustible liquids used for operation of machinery or equipment.
9. Cleaning establishments which utilize the flammable liquids solvent having a flash point of 140 degrees F or higher in closed systems employing equipment listed by a nationally recognized testing laboratory, provided this use is separated from all other areas of the building by one hour occupancy separation.
10. Cleaning establishments which utilize a liquid solvent having a flash point at or above 200 degrees F.
11. Refrigeration systems.

INSTITUTIONAL OCCUPANCY "I"

Institutional Occupancy "I" includes among others, the use of a building or structure, or any portion thereof, in which people having physical or medical limitations because of health or age are harbored for medical treatment or care, or in which people are detained for penal or correctional purposes, or in which the liberty of the occupants is restricted. Institutional occupancies shall include the following sub-groups:

I-1 Institutional Occupancies for the care of ambulatory persons, such as children, aged persons, mentally retarded and convalescents including:

- Convalescent hospitals
- Child care facilities
- Nursing homes (ambulatory)
- Homes for the aged
- Mentally retarded care institutions

I-2 Institutional Occupancies used for medical or other treatment or care of persons, some of whom are non-ambulatory, suffering from physical or mental illness, disease or infirmity including:

- Hospitals
- Nursing homes (non-ambulatory)
- Sanitariums

I-3 Institutional Occupancies where the occupants are under some degree of restraint or restriction for security reasons including:

- Jails
- Prisons
- Reformatories
- Other detention or correctional facilities

MERCANTILE OCCUPANCY “M”

Mercantile Occupancy “M” includes among others, all buildings and structures or parts thereof, for the display and sale of merchandise, and involving stocks of goods, wares or merchandise incidental to such purposes and accessible to the public.

Mercantile Occupancies include the following:

- Department stores
- Drug stores
- Markets
- Retail stores
- Shopping centers
- Sales rooms

RESIDENTIAL OCCUPANCY “R”

Residential Occupancy “R” includes among others, the use of a building or structure, or a portion thereof, for sleeping accommodations when not classed as an institutional occupancy. Residential occupancies shall include the following:

R1 Residential Occupancies where the occupants are primarily transient in nature (less than 30 days) including:

- Hotels
- Motels
- Boarding houses (transient)

R2 Residential Occupancies are multiple dwellings where the occupants are primarily permanent in nature, including:

- Apartment houses
- Boarding houses (not transients)
- Dormitories
- Fraternities and sororities
- Monasteries
- Convents

R3 Residential Occupancies are one (1) and two (2) family dwellings where the occupants are primarily permanent in nature and not classified as R1, R2, or I.

STORAGE OCCUPANCY “S”

Storage Occupancy “S” includes among others, the use of a building or structure, or a portion thereof, for storage that is not classed as a hazardous occupancy.

S-1 Moderate Hazard Storage includes among others, buildings used for the storage of combustible materials when not classified as Low Hazard S-2 or Hazardous “H”.

S-2 Low Hazard Storage includes among others, buildings used for the storage of noncombustible materials such as products on wood pallets or in paper cartons without significant amounts of combustible wrappings. Such products may have a negligible amount of plastic trim such as knobs, handles, or film wrapping. Examples:

- Metal desks with plastic tops and trim
- Electrical coils
- Electrical motors
- Dry cell batteries
- Metal parts
- Empty cans
- Stoves
- Washers and dryers
- Metal cabinets
- Glass bottles, empty or filled with noncombustible liquids
- Mirrors
- Foods in noncombustible containers
- Frozen foods
- Meats
- Fresh fruits and vegetables in nonplastic trays or containers
- Dairy products in nonwaxed coated paper containers
- Beer or wine up to 12 percent alcohol in metal, glass or ceramic containers
- Oil-filled and other types of distribution transformers
- Cement in bags
- Electrical insulators
- Gypsum board
- Inert pigments
- Dry insecticides

UTILITY AND MISCELLANEOUS USE “U”

Utility and Miscellaneous Use “U” includes among others, accessory buildings and structures, such as:

- Fences over 6 ft. high
- Tanks
- Cooling towers
- Retaining walls
- Buildings of less than 1,000 sq. ft. such as:

Private Garages
Carports
Sheds
Agriculture buildings

MIXED OCCUPANCIES

A building that is used for two or more occupancies, classified within different occupancy groups, shall be governed by the Height and Area limitations applying to the principal intended use. Minor accessory occupancies not occupying more than 10 percent of the area of any floor of a building, nor more than the tabular values for either height or area for such occupancy shall be permitted without reclassifying the major use of the building.

INDEX

- Access panels** 19, 164
- Adjoining property** 20, 21, 172
- Air conditioning system** 159, 164
- Air ducts** 159
- Air-handling systems** 160
- Air-supported structures** 56
- American Insurance Association** 200, 202, 205
- American Iron and Steel Institute** 38, 44, 72, 116, 122, 125, 127, 130, 146
- American Society for Testing and Materials**
 - specification for
 - fire-tests, building constructions and materials (E119) 31, 42, 44, 109-115, 118-136, 144, 145, 154
 - fire-tests, doors (E152) 154
 - interior finish (E84) 156, 157
 - roof coverings (E108) 114
 - spray applied materials (E605) 138
- Anoxia** 16
- Arches** 105, 127
- Area, building**
 - automatic fire-extinguishing systems and 166, 205, 206
 - combustible structures 23, 198, 199
 - covered malls 74
 - criteria for permissible 196, 200, 201
 - fire load and 23, 195, 196, 201, 204, 206
 - increase for accessible perimeter 204, 205
 - limitations in codes 197
 - multistory buildings 202, 203, 204
 - noncombustible structures 23, 198, 199, 206
 - occupancies 195, 206
 - unlimited 196-199, 206
- Areas of refuge** 58, 65, 66, 83, 87, 89, 161, 162
- Assembly occupancies** 217, 218
 - area limitations 206
 - air-supported structures 56
 - aisles 85
 - characteristic hazards 55, 85
 - combustible contents 54
 - decorations 18, 19, 55
 - exits, *see* Exits
 - exit capacity 82
 - fire loads 54, 75
 - fire severity, 75
 - furnishings 18
 - hazard group 55
 - height limitations 208
 - interior finish 18, 19, 55, 156
 - occupant density 81
 - panic 18, 19, 55, 85
 - seating 53, 55, 56, 81
 - stages 55
 - stairways 82
 - tents 56
- Automatic fire-extinguishing system** 102
 - basements 164, 168
 - building area and 166, 205, 206
 - cellars 164
 - exhibition halls 73
 - exits and 17, 167
 - fire-resistive requirements and 103, 166, 167
 - fire spread 166, 167
 - height and 164, 166
 - high rise buildings 168
 - garages 168
 - installation requirements 102, 166
 - limited exterior openings 175
 - unlimited area 206
 - windowless buildings 168
- Automobile parking structures** 72, 73
- Balconies** 78, 86
- Basements**
 - automatic fire-extinguishing equipment 164, 168
 - fire-protection requirements 164, 168
- Basic Building Code** 5, 78
 - area limitations 196-199, 202-206
 - classification of construction types 93, 97
 - height limitations 196-198, 206, 208
- Beams**
 - fire-resistance requirements 99, 100, 101
 - fire-resistance testing 25, 120, 126, 127, 130, 133, 134
- Bearing walls, *see* Walls**
- Board for Coordination of Model Codes** 7, 53, 56, 58, 61, 63, 64, 67, 70, 80, 83, 87, 89, 99, 103, 104, 217-226
- Boiler rooms** 164
- Bowling alleys** 81
- Building codes, *see* name of code**
- Building laws** 1, 2, 195, 200

Building Officials and Code Administrators International 5

Building regulations

fire safety 12-14
history 1-3
objectives, 11

Building separation 21, 171, 172, 174-176

Burnout tests 35, 38, 39, 143, 145
ventilation effect 39, 40

Business occupancies 56-58, 218, 219
area limitations 196-198, 206
characteristic hazards 57
combustible contents 56
derating factors 57
exit capacity 82
fire loads 57, 58, 75
fire severity 75
hazard group 56
height limitations 196-198, 209
occupant density 81

Canadian Standards Association

fire resistive testing 25

Ceilings

firestopping combustible spaces 104, 158
fire resistant testing 118, 158, 159
fire spread 158, 159
interior finish 156
membrane systems 118, 129
poke-through construction 160

Chimneys 165

Clay tile

column covers 139, 140

Columns

fire-resistance requirements 99, 100, 101
fire-resistance testing 25
liquid-filled 141, 142, 143
steel, fire-resistance testing 112, 122-126
wood (heavy timber) 105, 107, 112

Combustible construction 94, 95, 99
see Types of Construction

Combustible contents of occupancies

assembly 18, 54
automobile parking structures 72
business 56
educational 59
hazardous 63
industrial 61
institutional 64
mercantile 66
residential 67
storage 70

Combustible materials

exterior walls 186, 188
in conflagrations 21, 191
interior finishes 18, 65, 156, 157
in steel containers 56, 57, 58
within ducts 159

Combustibility of materials

ignitability 21, 159, 174, 175, 188

rate-of-heat-release 38

Concealed spaces 103, 104, 105

Concrete 120, 121, 138

Conflagrations 4, 20, 21, 25, 27, 191

Construction types

see Types of Construction

Cooling towers 71

Corridors

as exits 78, 82, 84
dead-end 84
exterior 86

Council of American Building Officials 6, 7

Court rooms

occupant density 81

Courts

exit 78

Coverings, roof, *see* Roof coverings

Dampers 160

Decorations 18, 19, 55

Doors

exit 16, 78, 82, 85
heat radiating from 90
fire-protection requirements 154, 155
horizontal exits 78

Doorways 78

Dry standpipes 168

Ducts

combustibles within 159
construction 159, 160
exhaust 159, 160
smoke spread 159

Educational occupancies 58-61, 82, 219

area limitations 196-199
characteristic hazards 60
combustible contents 59
exit capacity 82
exits, *see* Exits
fire loads 59
fire severity 60
height limitations 196-199
occupant density 81

Egress

see Exits

Electrical circuits 160

Elevators 82, 83, 88, 89, 161

Escalators 16, 78, 82

Exhaust ducts 159, 160

Exhaust system 163

Exhibition halls 54, 73

Exits

access 78
arrangement 83, 85
automatic fire-extinguishing systems and 17

- balconies 78, 86
- basic requirements 78
- capacity 78, 79, 80, 82, 167
- corridors 78, 82, 84, 86
- courts 78
- design of 16, 17, 85, 89
- discharge 78
- distance to 16, 83, 167
- doors 16, 78, 82, 85
- doorways 78
- elevator shafts 83
- elevators 82, 83, 88, 89, 161
- emergency 17, 19, 83
- enclosures 78, 90, 152
- exterior 85, 86
- fire escapes 77, 86
- fire-protection requirements 87
- handicapped, provisions for 88, 90
- horizontal 78, 79, 87, 88
- interior finish 156
- location 83
- lobbies 78, 86, 89
- main floor 86, 89
- malls 16, 73, 74
- moving stairs 78, 82
- number of 85
- obstructions 78
- occupancy requirements 80, 85
- passageways 78, 85, 87
- ramps 16, 78, 79, 82, 85
- refuge areas 83, 87, 89
- signs 18, 19, 83
- smokeproof towers 86, 87
- stairways 16, 77-80, 82, 83, 85-88
- tall buildings 83, 88, 89
- travel distance 83, 84, 86
- types of 78
- unit width 79

Exitways 79, 85, 167

Explosion venting, 63

Exterior exits 86

Exterior walls
see Walls exterior
 windows in 171, 177-182, 184, 188-190

Extinguishing agents 166

Extinguishing equipment,
see Automatic fire-extinguishing equipment

Factory-industrial occupancies 61, 62, 219, 220
 area limitations 62, 206
 characteristic hazards 62
 combustible contents 61
 exit capacity 82
 exits, *see* Exits
 fire load 61, 62, 75
 fire-protection requirements 62, 102, 185
 fire severity 75
 height limitations 62, 206, 209
 occupant density 81

Fences 71

Finish, *see* Interior finish

Fire alarms 16, 18, 71, 162

Fire doors 86, 87, 154, 155, 160

Fire endurance
 fire loads 34, 36
 testing 26-28, 35
 time-temperature curve 36

Fire-escapes 77, 86

Fire-extinguishing systems
see Automatic fire-extinguishing systems

Fire fighters, safety of 11, 19, 152, 153

Fire loads
 area and 23, 195, 196, 201, 204, 206
 assembly occupancies 53-55, 75
 business occupancies 56-58, 75
 concept 31, 34
 educational occupancies 58-60, 75
 factory-industrial occupancies 61, 62, 75
 fire endurance and 34, 36
 hazardous occupancies 62, 63, 75
 height and 23, 201
 industrial occupancies 61, 62, 75
 institutional occupancies 64, 65, 75
 mercantile occupancies 66, 67, 75
 mixed occupancies 51
 residential occupancies 67-69, 75
 storage occupancies 70, 71, 75
 special occupancies 71-74
 automobile parking structures 71-73
 exhibition halls 73
 high-stacked storage occupancy 74
 malls, covered or enclosed 73, 74
 time-temperature curve and 31, 35, 40-42
 utility/miscellaneous use occupancies 71

Fire-protection rating 154, 155

Fire-protection requirements
 basements and cellars 164
 boiler rooms 164
 doors 155
 duct construction 159
 elevators 155
 exits 16, 18
 exterior walls 103, 113, 155
 fire doors 15, 154, 160
 fire walls 15, 155
 fire windows 154
 firestopping 15, 158, 159
 floors 15
 general 166
 joists 100
 mixed occupancy 51
 moving stairs 152
 partitions 155
 roofs 153
 shafts 152
 stairways 155
 standpipes 168
 vertical openings 151, 152
 wall openings 154, 155, 184
 windows 184

Fire-protective materials 135-139
 brick 139
 concrete 138

- flame shielding 142, 144
- gypsum 125, 137
- masonry 20, 139
- metal lath 137
- perlite 137-139
- spray-applied materials 137-139, 140, 144
- vermiculite 137-139

Fire resistance

- building design 40

Fire-resistance ratings

- alternates to 100, 101, 167
- elevators 152
- exits 87, 90, 152
- exterior walls 184, 185, 190
- for separation of mixed occupancies 51
- listings 44, 110
- partitions 154
- restraint, effects of 118, 119
- stairways 152
- vertical openings 154
- walls 88, 122, 154

Fire-resistance requirements

- beams 99-101
- firestopping combustible spaces 158, 159
- columns 99-101
- exterior walls 21, 96, 171, 172, 184-188
- floors 96, 99-101
- girders 99-101
- lintels 100-101
- roofs 99-101
- spandrel walls 99-101
- for structural elements 96, 99-101
- trusses 99-101, 127, 198
- walls 99-101, 184, 188

Fire-resistance testing

- beams 25, 119, 126
- ceilings 118, 158, 159
- columns 25, 28, 112
- columns, liquid-filled 142, 143
- concrete 120, 121
- design information for assemblies 110, 111
- development of 26, 31
- exposure conditions 43
- floors 25, 26, 28, 29, 106, 112, 113, 118-121, 126, 127, 129, 130
- girders, *see* Beams
- gypsum 125, 126
- history 25-28, 109
- masonry 139
- membrane ceiling systems 118, 129
- partitions 25, 28, 113, 119, 122
- perlite 137-139
- restraint 118-121, 126, 130
- roofs 25, 112-114, 118-121, 126, 129, 130
- size of assemblies 118, 119, 123
- spray-applied materials 137-139
- steel
 - beams 112, 120, 126, 127, 130, 133, 134, 136
 - columns 112, 122-126
 - at elevated temperatures 112, 123, 124, 130-136
 - flame shielding 145

- floors 130-134
- girders 112, 126
- joists 120, 130
- materials for protecting 125, 127
- roof decks 130
- time-temperature curve 30-33, 35-40, 110, 113-116, 118, 142, 145
- walls 25, 28, 29, 112, 113, 119-122, 188-190

- Fire severity** 34-37, 52, 75, 114, 118, 196, 201

- Fire-shutters** 86, 106

Fire spread

- adjoining property 11, 20, 172
- building separation 153, 171, 172, 174-176
- exterior walls 155, 171, 172, 177-185, 188-190
- factors contributing to 14, 22, 151, 152
- firestopping 15, 158, 159
- openings in partitions 154
- openings in walls 154, 174, 177-185, 188-190
- thermal radiation 172-174
- vents 165
- vertical openings 15, 151, 152, 188-190
- windows 174, 188-190

- Firestopping** 104, 158, 159

- Firestops** 15, 159

- Fire testing**, *see* Fire-resistance testing

Fire walls

- fire-protection requirements 155
- fire resistance requirements 107, 122, 185, 188
- fire spread 21, 153-155, 185, 188, 196
- openings 155, 196

- Fire Windows** 154

- Fires**, causes 14, 21

- Fires**, losses 12-14

- Flame spread**, *see* Interior finish

- Floor finish** 65

Floors

- concealed spaces 22, 104
- fire-resistance requirements 96, 99-101
- fire-resistance testing 25, 26, 29, 106, 112, 113, 120, 121, 126-128, 130-134, 158, 159
- steel 112, 130, 134
- wood 53, 54, 69, 105, 106

- Flues**, concealed spaces acting as 158

- Fuel contribution** 95, 106, 157

- Furnace rooms** 164

- Gas vents** 165

Gases

- corrosive 158
- inhalation of 16, 157
- toxic 17, 52, 55, 63, 77, 157, 158

Girders

- fire-resistance requirements 99-101
- fire-resistance testing 126
- heavy timber construction 105

Halls, *see* Corridors

Handicapped

exits and 17, 79, 80, 85, 88, 90

Hazardous occupancies 62, 63, 220-223

automatic fire-extinguishing systems 63
characteristic hazards 63
combustible contents 63
construction requirements 63
exit capacity 82
explosion venting 63
fire load 63, 75
fire severity 63, 75
hazard group 63
height limitations 208, 209
occupant density 81

Heat release

Rate of (RHR) 38

Heat-transmission end point 160

Heights, building

allowable, stories and feet 196-199
automatic fire-extinguishing systems and 164-166
combustible structures 23, 198, 199
construction type 103, 198, 199
criteria for determining 196, 200, 201
current limitations 207
fire load and 23, 201
limit criteria 195-199
noncombustible structures 23, 198, 199
standpipes and 168
unlimited 196-199, 207

High-rise buildings 88, 161, 168, 208

High-stacked storage occupancy 74

Horizontal exits 78, 87, 88
occupant load 88

Ignitability 21, 159, 174, 175, 188

Illumination of exits and exitways 185

Incombustible materials,

see Noncombustible materials

Industrial occupancies, Factory-

see Factory-industrial occupancies

Inhalation of gases and smoke 16, 157

Institutional occupancies 64, 66, 223, 224

characteristic hazards 65
combustible contents 64
construction types 64
exit capacity 82
fire loads 64, 65, 75
fire severity 75
hazard group 64, 65
height limitations 208
interior finish 156
occupant density 81

Interior finish

ceilings 156

combustible 18, 19, 65, 156, 157, 167

exits 156

fire-protection requirements 167

flame-spread classification 157, 167

Interior structure

automatic fire-extinguishing systems 165-167
basements 164
boiler room 164
ceilings 158-159
cellars 164
chimneys 165
ducts 159
finish 156, 157, 167
fire-resistive assemblies 160
fire spread 22
fire walls 153, 185, 188
firestopping, 158, 159
furnace room 164
openings in partitions 154, 155
openings in walls 154, 155
standpipes 168
vents 165
vertical openings 151, 152
windowless buildings 163

Interior trim 53, 60, 65, 67-69

Interior walls,

see Partitions; Walls, party

International Conference of Building Officials
5

ISO-International Standards 42, 43

Joint Fire Research Organization of Great Britain 188

Joists

fire-resistance requirements 100
fire-resistance testing 116, 120, 130, 158

Lath 139, 159

Laws, building 1, 2, 195, 200

Libraries 54

occupant density 81

Life-safety 15, 17, 18, 19, 71, 77, 156,
161, 162, 207, 208

Lights, exit 85

Lintels, fire-resistance requirements 100, 101

Liquid-filled columns 141, 142, 143

Load-bearing exterior walls 171, 185, 186

Lobbies 78

Malls, covered or enclosed 73, 74

Masonry

fire resistance of 95
as protection 20, 139, 159, 171

McCormick Place fire 55, 73

Mechanical ventilation, *see* Ventilation

Membrane ceiling systems 118

- Mercantile occupancies** 66, 224
 - area limitations 206
 - characteristic hazards 67
 - combustible contents 66
 - exit capacity 82
 - exits 67
 - fire loads 66, 67, 75
 - fire-protection requirements 67, 102
 - fire severity 67, 75
 - hazard group 66
 - height limitations 208, 209
 - occupant density 81
 - stairways 82
- Metal frame buildings**, *see* Noncombustible construction
- Metal lath** 139, 159
- Mill construction** 104
- Mineral fiber**, *see* Spray-applied materials
- Mixed construction type** 107
- Mixed occupancies** 50, 51, 226
 - area limitations 51
 - fire-protection requirements 51
 - height limitations 51
 - separation of 51, 60
- Model codes** 4-7, 50
 - see also* codes by name
- Model Codes Standardization Council** 6, 50, 96-99
- Monumental stairways** 152
- Moving stairs** 82
- Multistory buildings**
 - area limitations 202, 203, 205
 - exit capacity 80
- National Building Code**
 - (**American Insurance Association**) 4, 5, 20
 - area limitations 202, 205
 - classifications of construction types 93, 97
 - National Building Code of Canada** 5, 103, 177, 184
 - area limitations 200, 202, 205, 206
 - classification of construction types 94-96
 - fire-resistance ratings 94
 - height limitations 200, 209
 - noncombustible materials 94, 95
 - National Bureau of Standards** 4, 16, 28, 31, 52, 54, 56, 57, 59, 61, 64, 66, 68, 77, 79, 106, 158
 - National Fire Protection Association**
 - life loss statistics 13, 14, 16, 68, 156, 197
 - standards
 - air conditioning systems 160, 164
 - automatic fire-extinguishing systems 166
 - chimneys 165
 - exits 16, 77
 - fire doors 154
 - fire resistance testing 25
 - fire windows 154
 - interior finish 157, 158
 - life safety 16, 77, 80, 82-84, 87, 129, 157, 158, 161
 - rack storage 74
 - roof coverings 191
 - standpipes 20, 168
 - vents 165
- National Research Board** 7
- National Research Council of Canada** 5, 6, 39, 175, 176
- New York City Building Code** 26, 44, 88
 - area limitations 202, 205
 - classification of construction types 96
- Non-bearing exterior walls** 171, 184-186
- Noncombustible construction** 60, 94-96, 99, 100, 102, 103, 203
- Noncombustible exterior walls** 171, 174, 186
- Noncombustible materials** 94, 95, 102, 159
- Noncombustible structures**
 - area limitations 73, 206
 - height limitations 73, 209
- Occupancies**, (*see* specific occupancy classifications)
 - fire severity potential 52
 - hazards 52
 - use changes 51
- Occupant load** 80, 82
- Occupants**
 - safety of 11, 15, 20, 195, 196
- Offices**
 - fire loads 57, 58
- One-and two-family dwelling code** 7, 8
- Openings**, wall
 - exterior
 - equivalent opening factor 183
 - fire protection rating 154
 - fire spread, between buildings 172-175
 - fire spread, story to story 188-190
 - permissible extent of 178, 182
 - interior 155, 186, 196
- Panel walls** 171, 184, 189, 190
- Panic** 16-19, 163
- Parapet walls** 153, 185, 188
- Parking garage**
 - occupant density 81
- Partitions**
 - corridor 153, 154
 - fire-resistance testing 113, 119
 - openings in 154, 155
 - smoke-stop 66
 - vertical opening enclosure 151
- Party walls** 185, 188
- Passageways** 78, 87
- Passenger terminals** 55
- Perlite** 137, 139
- Poke-through construction** 160

- Rack storage** 74
- Radiant energy** 172-175, 177
- Radiation, thermal** 172-174
- Ramps**
 - as exits 16, 78, 79, 82, 85
 - slope of 82
- Rate of Heat Release (RHR)** 38
- Refuge areas** 89, 161, 162
- Residential occupancies** 67, 68, 224
 - area limitations 196-199
 - basements 164
 - cellars 164
 - characteristic hazards 68
 - combustible contents 67
 - exit capacity 82
 - exits, *see* Exits
 - fire loads 67-69, 75
 - fire severity 69, 70, 75
 - hazard group 68, 69
 - height limitations 196-199, 209
 - interior finish 156
 - occupant density 81
- Restraint** 118-121, 126, 130
- Risers** 89
- Roofs**
 - concealed spaces 104
 - construction 100, 101
 - coverings 102, 191
 - fire-protection requirements 100, 101, 153
 - fire-resistance requirements 99-101
 - fire-resistance testing 25, 112-114, 129, 130
- Safety**
 - adjoining property 11, 20, 21
 - fire fighters 19
 - objectives 11
 - occupants 11, 15, 20
- Separations**
 - see* Walls
- Shutters, fire** 86, 106
- Signs, exits** 18, 19, 85
- Smoke**
 - detectors 20, 66, 89
 - development of 55, 157
 - hazards 16, 52, 157, 158
 - removal 19, 163
 - spread 15, 159
- Smokeproof towers** 86, 87
- Southern Building Code Congress** 5
- Spandrel walls**
 - fire-resistance requirements 99-101
- Spray-applied materials** 137-139, 140, 144
- Sprinklers** 20, 83, 84, 86, 100, 101, 163, 165-167, 177-182, 200, 205-209
- Stage** 55
- Stairways**
 - see* Exits
- Standard Building Code** 5, 78
 - area limitations 196-199, 202, 205, 206
 - classification of construction types 97
 - height limitations 196-199, 206, 209
 - standpipes 168
- Standard Fire Test** 109-114, 118-136, 144-146
 - alternates to 146
- Standard Fire Test Curve** 30
- Standpipes**
 - building height and 168
 - dry 168
 - fire-protection requirements 20, 168
- Steel**
 - architecturally exposed 139, 140, 142
 - chimneys 165
 - containers, combustibles in 56-58
 - fire-resistance testing
 - beams and girders 112, 126
 - columns 112, 122-126
 - floors 130, 134
 - joists 120, 130
 - materials for protecting 135-139
 - roof assemblies 130
 - framed wired glass windows 177-182, 184
 - joists
 - properties at elevated temperatures 130-135
- Storage occupancies** 70, 225
 - area limitations 206
 - characteristic hazards 71
 - combustible contents 70
 - exit capacity 82
 - exits, *see* Exits
 - fire loads 70, 75
 - fire-protection requirements 70, 71, 102
 - fire severity 70, 75
 - hazard group 70
 - height limitations 209
 - high-stacked 74
 - occupant density 81
- Structural frames**
 - fire resistance requirements 97, 99-101
- Surface flame spread** 156, 157
- Tanks** 71
- Tents** 56
- Thermal radiation** 172-174
- Toxic gases**
 - see* Smoke
- Travel distance to exits** 83, 84, 86, 167
- Trim, interior** 53, 60, 65, 67-69
- Trustees** 99-101, 127, 128
- Tunnel test, ASTM E84,** 156
- Types of construction** 93-108
 - area limitations 197-199, 202, 203
 - height limitations 197-199
 - mixed 107
 - Type I 97-100, 102, 197-199
 - Type II 97, 98, 100, 102, 103, 107-199
 - Type III 97, 100, 103, 104, 197-199, 206
 - Type IV 97, 98, 100, 104-106, 197-199
 - Type V 97, 98, 100, 107, 197-199

Underwriters' Laboratories Inc. 3
fire-resistive ratings 116, 117, 122
fire-resistive testing 25, 28, 124,
127, 130, 143, 145
roof coverings 191
vents 165

Uniform Building Code 5, 78, 90
area limitations 196-200, 202,
205, 206, 209
classification of construction types 97
fire resistance ratings 44
height limitations 196-200, 208, 209

Utility/miscellaneous use occupancies 71, 225

Ventilation 38-40

Vents 165

Vermiculite 137-139

Vertical openings

fire-protection requirements 151, 152
fire spread by 15, 151, 152
enclosure for 15, 151, 152, 154

Wallboard, gypsum 102

Wall openings

see Openings, wall

Walls

exterior

bearing 96, 171, 185, 186
building separation 171, 172, 175, 176,
185
fire-resistance requirements 99-101, 107,
112, 113, 119, 184-186
non-combustible 174
openings in 175-185, 188-190
panel 184, 189, 190
parapet 185
unprotected noncombustible 184
windows in 171, 177-182, 184, 188-190

interior

see Partitions
party 85

Wet standpipes 168

Windowless buildings 163, 168

Windows

exterior walls 171, 174, 177-182, 188-190
frames 177-182
steel-framed wired glass 177-182, 184



AMERICAN IRON AND STEEL INSTITUTE
WASHINGTON, D.C.